

AURORA® MODEL 326A PUMP

INLINE CENTRIFUGAL PUMP

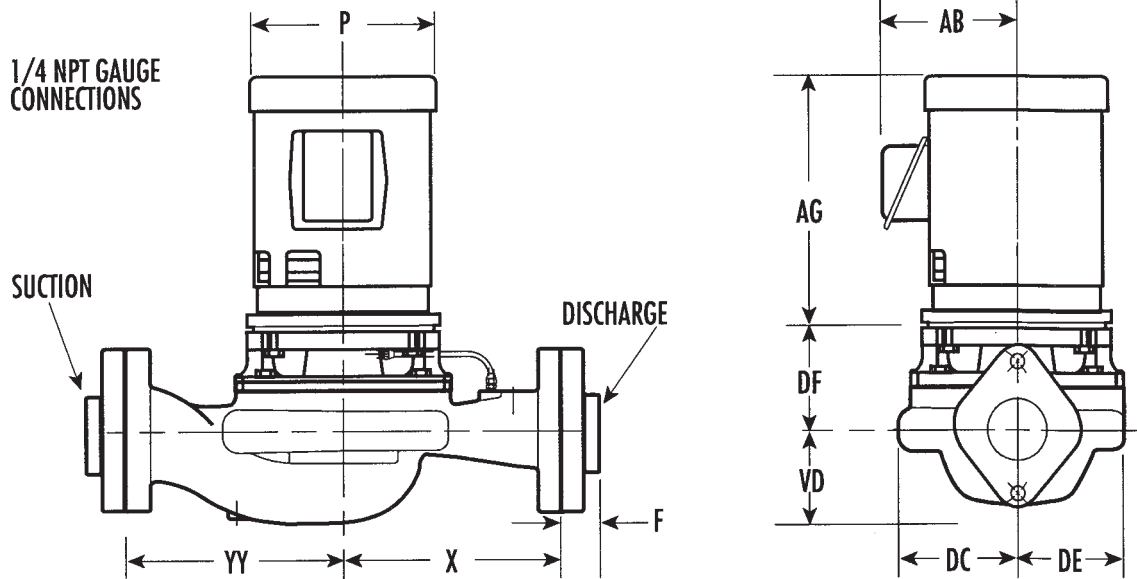

NOTES:

1. Dimensions and weights are approximate.
2. All weights are in pounds or kilograms (kg).
3. All dimensions are in inches or metric (mm) and may vary ± .25" (6).
4. Conduit box is shown in approximate position. Dimensions are not specified (as they vary with each motor manufacturer).
5. Add pump and motor weight for unit weight.
6. Not for construction purposes unless specified.
 - * 1phase, (145TCZ), 3 phase (56CZ).
 - 1phase, (1 HP)
 - 1phase, (1-1/2 HP)
 - † 1phase, (1/2 HP)

Maximum Operating Pressure 175 psi

1750 (60 hz)/1440 (50 hz) RPM

Maximum Operating Temperature 225° (107°C)

MODEL	SUPER GA MOTOR HP	X	YY	VD	DF	DC	DE	F	PUMP WEIGHT	TEFC MOTOR FRAME	TEFC MOTOR WEIGHT	DIMENSIONS MAY VARY BY MANUFACTURER AND HP		
												AG	P	AB
1-1/4 x 1-1/4 x 6, Model "B"	3/4 [†]	4-1/2 (114)	6-1/2 (165)	3-3/8 (86)	2-7/8 (73)	3-1/2 (89)	3-1/2 (89)	7/8 (22)	17 (7.7)	56CZ	Use 1/2 hp	11 (279)	6-5/8 (168)	5 (127)
1-1/4 x 1-1/4 x 6	3/4 [†]	4-1/2 (114)	6-1/2 (165)	3-3/8 (86)	2-7/8 (73)	3-1/2 (89)	3-1/2 (89)	7/8 (22)	17 (7.7)	56CZ	40 (18.1)	11 (279)	6-5/8 (168)	5 (127)
1-1/2 x 1-1/2 x 6	3/4 [†]	4-1/2 (114)	7 (178)	3-3/4 (95)	2-7/8 (73)	3-1/2 (89)	3-3/4 (95)	7/8 (22)	23 (10.4)	56CZ	Use 1/2 hp	11 (279)	6-5/8 (168)	5 (127)
1-1/2 x 1-1/2 x 6, Model "C"	3/4 [†]	4-1/2 (114)	7 (178)	3-3/4 (95)	2-7/8 (73)	3-1/2 (89)	3-3/4 (95)	7/8 (22)	23 (10.4)	56CZ	40 (18.1)	11 (279)	6-5/8 (168)	5 (127)
1-1/2 x 1-1/2 x 6	3/4 [▪]	4-1/2 (114)	7 (178)	3-3/4 (95)	2-7/8 (73)	3-1/2 (89)	3-3/4 (95)	7/8 (22)	23 (10.4)	56CZ	Use 1 hp	11 (279)	6-5/8 (168)	5 (127)
2 x 2 x 6	3/4 [†]	4-3/4 (121)	6-3/4 (171)	3-3/4 (95)	2-7/8 (73)	3-3/4 (95)	4 (102)	7/8 (22)	23 (10.4)	56CZ	40 (18.1)	11 (279)	6-5/8 (168)	5 (127)
2 x 2 x 6, Model "D"	3/4 [▪]	4-3/4 (121)	6-3/4 (171)	3-3/4 (95)	2-7/8 (73)	3-3/4 (95)	4 (102)	7/8 (22)	23 (10.4)	56CZ	Use 1 hp	11 (279)	6-5/8 (168)	5 (127)
2 x 2 x 6	1-1/2 [*]	4-3/4 (121)	6-3/4 (171)	3-3/4 (95)	2-7/8 (73)	3-3/4 (95)	4 (102)	7/8 (22)	23 (10.4)	56CZ	50 (22.7)	11 (279)	6-5/8 (168)	5 (127)
1-1/2 x 1-1/2 x 7, Model "F"	1/2	5-1/2 (140)	8 (203)	4 (102)	2-7/8 (73)	4 (102)	4-1/4 (108)	7/8 (22)	25 (11.3)	56CZ	40 (18.1)	11 (279)	6-5/8 (168)	5 (127)
1-1/2 x 1-1/2 x 7, Model "G"	3/4 [▪]	5-1/2 (140)	8 (203)	4 (102)	2-7/8 (73)	4 (102)	4-1/4 (108)	7/8 (22)	25 (11.3)	56CZ	Use 1 hp	11 (279)	6-5/8 (168)	5 (127)
1-1/2 x 1-1/2 x 7, Model "H"	1-1/2 [*]	5-1/2 (140)	8 (203)	4 (102)	2-7/8 (73)	4 (102)	4-1/4 (108)	7/8 (22)	25 (11.3)	56CZ	50 (22.7)	11 (279)	6-5/8 (168)	5 (127)
1-1/2 x 1-1/2 x 7	1-1/2 [*]	5-1/2 (140)	8 (203)	4 (102)	2-7/8 (73)	4 (102)	4-1/4 (108)	7/8 (22)	25 (11.3)	56CZ	50 (22.7)	11 (279)	6-5/8 (168)	5 (127)
1-1/2 x 1-1/2 x 7	1-1/2 [*]	5-1/2 (140)	8 (203)	4 (102)	2-7/8 (73)	4 (102)	4-1/4 (108)	7/8 (22)	25 (11.3)	56CZ	50 (22.7)	11 (279)	6-5/8 (168)	5 (127)
2 x 2 x 7	3/4 [▪]	6 (152)	8 (203)	4 (102)	2-7/8 (73)	4-1/4 (108)	4-3/4 (121)	13/16 (21)	26 (11.8)	56CZ	Use 1 hp	11 (279)	6-5/8 (168)	5 (127)
2 x 2 x 7, Model "I"	1-1/2 [*]	6 (152)	8 (203)	4 (102)	2-7/8 (73)	4-1/4 (108)	4-3/4 (121)	13/16 (21)	26 (11.8)	56CZ	50 (22.7)	11 (279)	6-5/8 (168)	5 (127)
2 x 2 x 7, Models "J" & "K"	1-1/2 [*]	6 (152)	8 (203)	4 (102)	2-7/8 (73)	4-1/4 (108)	4-3/4 (121)	13/16 (21)	26 (11.8)	*56CZ	60 (27.2)	11 (279)	6-5/8 (168)	5 (127)
2 x 2 x 7	2	6 (152)	8 (203)	4 (102)	2-7/8 (73)	4-1/4 (108)	4-3/4 (121)	13/16 (21)	26 (11.8)	145TCZ	60 (27.2)	11 (279)	6-5/8 (168)	5 (127)