

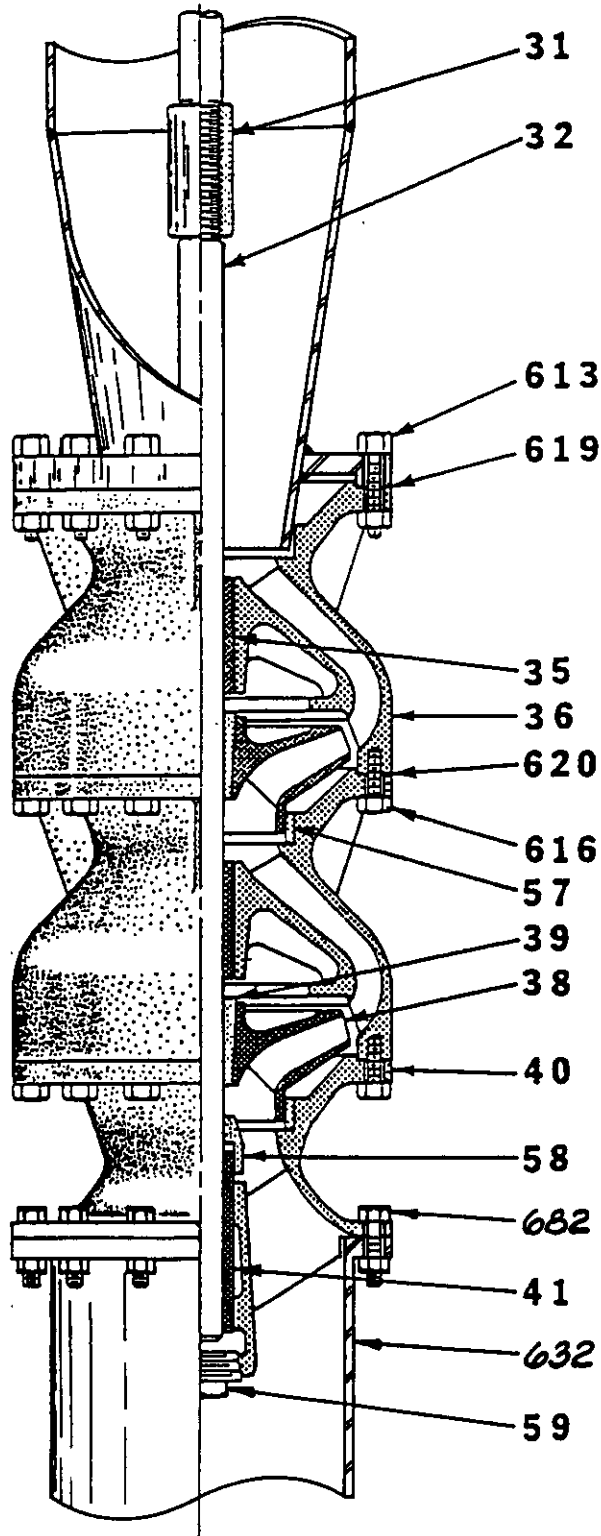

LAYNE & BOWLER
MEMPHIS, TN 38108 USA

SECTIONAL DRAWING
FLANGED, COLLET TYPE BOWLS
OPEN LINE SHAFT
FLANGED DISCHARGE CONN.
W/O DISCH CASE
18G W/SUCTION PIPE

DRWG. NO. _____
 DATE _____



NO. ITFM	PART NAME	MATERIAL	
		STD	OPTIONAL
660	BOWL ASSY	----	----
31	IMP. SHAFT COUPLING	STEEL	
32	IMPELLER SHAFT	410SS	
35	BEARING, INT.	BRONZE	
36	INTERMEDIATE	C. I. CL30	
38	IMPELLER	BRONZE	
39	COLLET	STN.STL.	
40	SUCTION BELL	C. I. CL30	
41	BEARING, SUCTION	BRONZE	
57	WEAR RING	BRONZE	
58	SAND COLLAR	RUBBER	
59	SUCTION PLUG	CAST IRON	
613	MACH.BOLT,BOWL/COL.	STEEL	
616	CAPSCREW,BOWL	N. T. STL.	
632	SUCTION PIPE	STEEL	
619	GASKET, BOWL/COL.	----	
620	GASKET, BOWL	----	
682	MACH BOLT,SUCT PIPE	STEEL	



LAYNE & BOWLER
MEMPHIS, TN 38108 USA

SECTIONAL DRAWING
FLANGED, COLLET TYPE BOWLS
OPEN LINE SHAFT
FLANGED DISCHARGE CONN.
W/O DISCH CASE
18G W/SUCTION PIPE

DRWG. _____
DATE _____

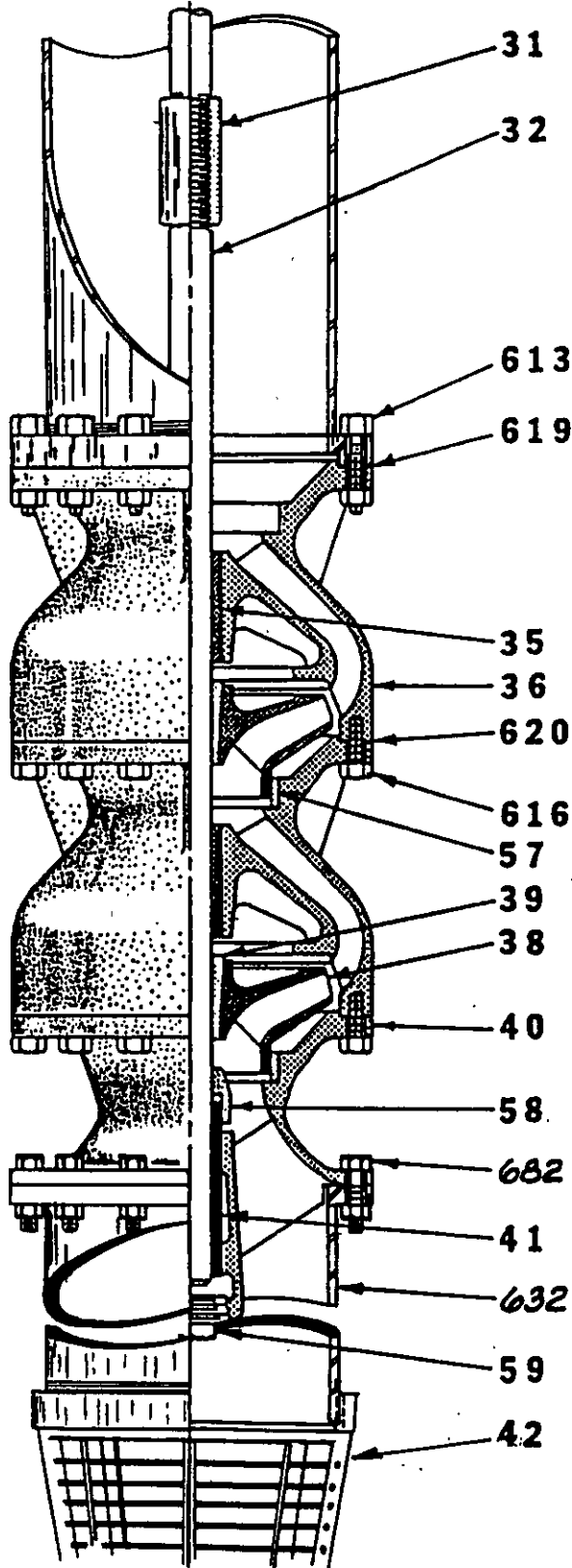

NO. ITRM	PART NAME	MATERIAL	
		STD	OPTIONAL
660	BOWL ASSY	---	---
31	IMP. SHAFT COUPLING	STEEL	
32	IMPELLER SHAFT	410SS	
35	BEARING, INT.	BRONZE	
38	INTERMEDIATE	C. I. CL30	
39	IMPELLER	BRONZE	
39	COLLET	STN. STL.	
40	SUCTION BELL	C. I. CL30	
41	BEARING, SUCTION	BRONZE	
42	STRAINER	ALV STL	
57	WEAR RING	BRONZE	
58	SAND COLLAR	RUBBER	
59	SUCTION PLUG	CAST IRON	
613	MACH. BOLT, BOWL/COL.	STEEL	
616	CAP SCREW, BOWL	H. I. STL.	
682	SUCTION PIPE	STEEL	
619	GASKET, BOWL/COL.	---	
620	GASKET, BOWL	---	
682	MACH. BOLT, SUCT PIPE	STEEL	

