

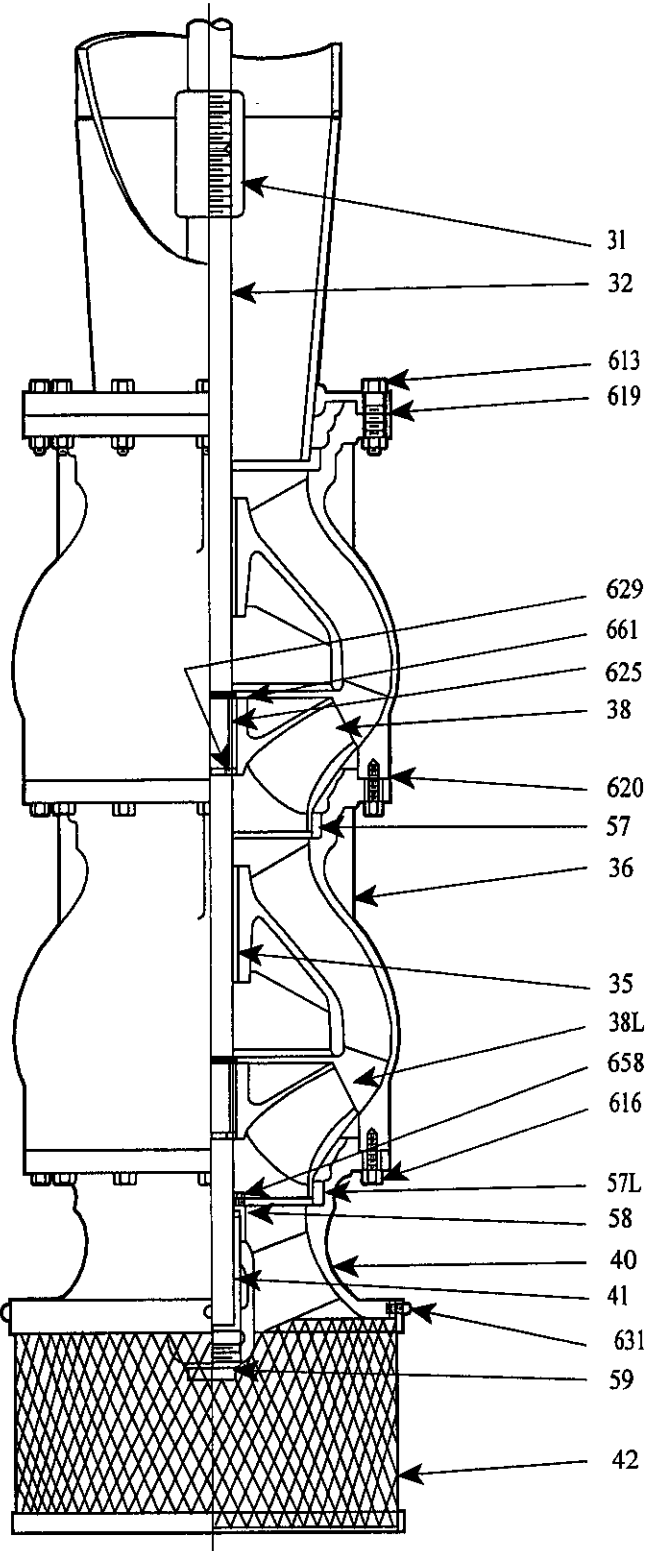

22, 24, 30G Bowl Assembly Open Line Shaft Flanged Column



Item No.	Part Name	Material	
		Standard	Optional
660	Bowl Assy	-----	
31	Imp. Shaft Coupling	Steel	
32	Imp. Shaft	416 S.S.	
35	Bearing, Bowl	Bronze	
36	Bowl	C.I. CL. 30	
38	Impeller	Bronze	
38L	Impeller, Low N.P.S.H.	Bronze	
40	Suction Bell	C.I. CL. 30	
41	Bearing, Suction	Bronze	
42	Strainer	Glv Stl	
38	54 Discharge Case	C.I. CL. 30	
57	Wear Ring	Bronze	
620	57L Wear Ring, Low N.P.S.H.	Bronze	
57	58 Sand Collar	Bronze	
36	59 Suction Plug	C.I.	
613	Fastener, Col/Bowl	Steel	
616	Fastener, Bowl	Steel	
35	618 Bearing, Discharge Case	Bronze	
38L	619 Gasket, Bowl/Col	-----	
658	620 Gasket, Bowl	-----	
616	625 Key, Impeller	Stn Stl	
57L	629 Split Thrust Ring	Stn Stl	
58	631 Machine Screw, Strainer	Stn Stl	
40	658 Set Screw, Collar	Stn Stl	
41	661 Retaining Ring	Stn Stl	

CROSS-SECTIONAL DRAWING

DRAWING NO. _____
DATE: _____



24, 30G Bowl Assembly Open Line Shaft Flanged Discharge Case

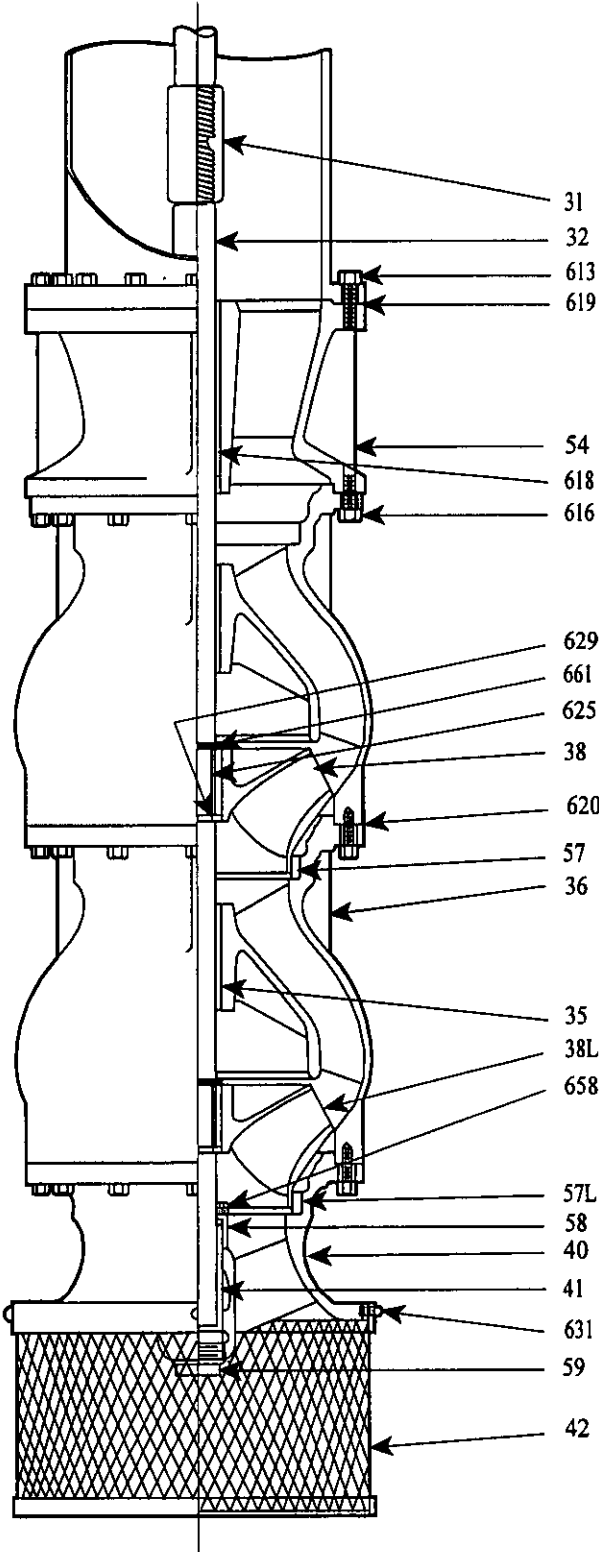

Item No.	Part Name	Material	
		Standard	Optional
660	Bowl Assy	-----	
31	Imp. Shaft Coupling	Steel	
32	Imp. Shaft	416 S.S.	
35	Bearing, Bowl	Bronze	
36	Bowl	C.I. CL. 30	
38	Impeller	Bronze	
38L	Impeller, Low N.P.S.H.	Bronze	
40	Suction Bell	C.I. CL. 30	
41	Bearing, Suction	Bronze	
42	Strainer	Glv Stl	
54	Discharge Case	C.I. CL. 30	
57	Wear Ring	Bronze	
57L	Wear Ring, Low N.P.S.H.	Bronze	
58	Sand Collar	Bronze	
59	Suction Plug	C.I.	
613	Fastener, Col/Bowl	Steel	
616	Fastener, Bowl	Steel	
618	Bearing, Discharge Case	Bronze	
619	Gasket, Bow/Col	-----	
620	Gasket, Bowl	-----	
625	Key, Impeller	Stn Stl	
629	Split Thrust Ring	Stn Stl	
631	Machine Screw, Strainer	Stn Stl	
658	Set Screw, Collar	Stn Stl	
661	Retaining Ring	Stn Stl	

CROSS-SECTIONAL DRAWING

DRAWING NO. _____

DATE: _____



22, 24, 30G Bowl Assembly Enclosed Line Shaft Flanged Discharge Case

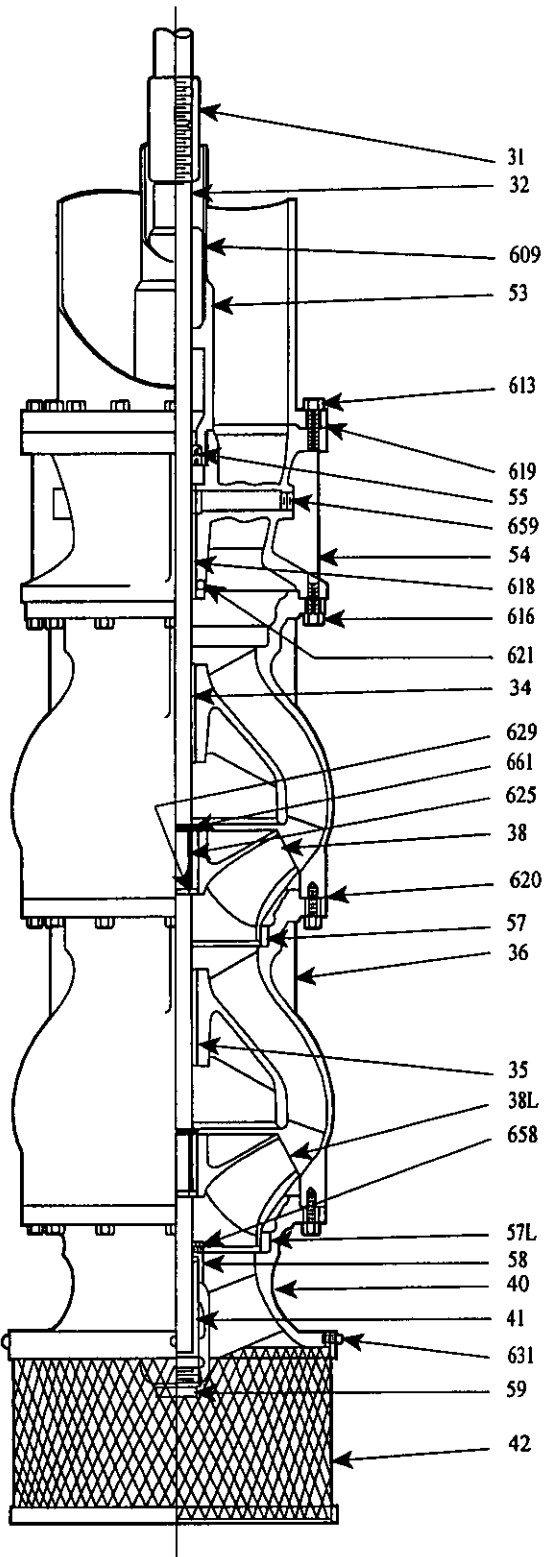

Item No.	Part Name	Material	
		Standard	Optional
660	Bowl Assy	-----	
31	Imp. Shaft Coupling	Steel	
32	Imp. Shaft	416 S.S.	
34	Bearing, Top Bowl	Bronze	
35	Bearing, Bowl	Bronze	
36	Bowl	C.I. CL. 30	
38	Impeller	Bronze	
38L	Impeller, Low N.P.S.H.	Bronze	
40	Suction Bell	C.I. CL. 30	
41	Bearing, Suction	Bronze	
42	Strainer	Gl. Stl.	
53	Tube Adapter	C.I. CL. 30	
54	Discharge Case	C.I. CL. 30	
55	Oil Seals	Rubber	
57	Wear Ring	Bronze	
57L	Wear Ring, Low N.P.S.H.	Bronze	
58	Sand Collar	Bronze	
59	Suction Plug	C.I.	
609	Main Bearing	Bronze	
613	Fastener, Col/Bowl	Steel	
616	Fastener, Bowl	Steel	
618	Bearing, Discharge Case	Bronze	
619	Gasket, Bowl/Col	-----	
620	Gasket, Bowl	-----	
621	O'Ring	Rubber	
625	Key, Impeller	Stn. Stl.	
629	Split Thrust Ring	Stn. Stl.	
631	Machine Screw, Strainer	Stn. Stl.	
658	Set Screw, Collar	Stn. Stl.	
659	Pipe Plug, Relief Ports	Cast Iron	
661	Retaining Ring	Stn. Stl.	

CROSS-SECTIONAL DRAWING

DRAWING NO. _____

DATE: _____