

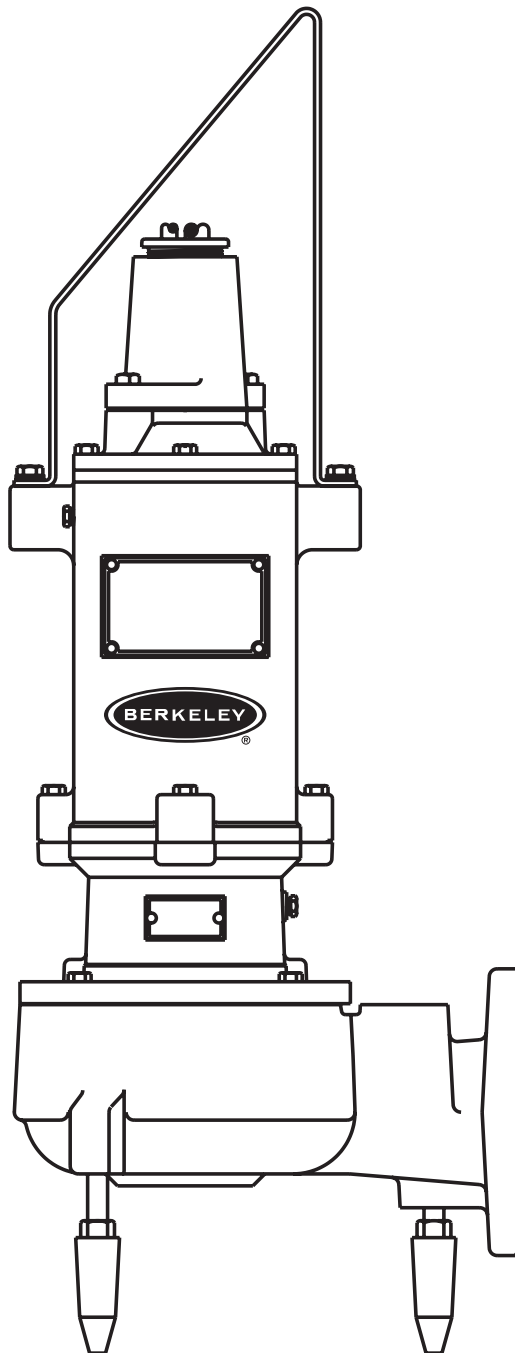

B-AG3 and B-AG5 SERIES

Agricultural Pumps

Installation and Service Manual



GENERAL INFORMATION

DESCRIPTION OF PUMP

Drawing Fig. 1 (Page 14), shows a sectional view of the AG/AGX series pumps. The pressure connectors are used on wire connections inside the motor cover.

CAUTION: In the initial installation before sewage is admitted to basin, there, of course, is no danger on entering sump, but after sewage has been in basin, there is DANGER. SEWAGE WATER GIVES OFF METHANE AND HYDROGEN SULFIDE GASES, BOTH OF WHICH ARE HIGHLY POISONOUS. NEVER ENTER WET WELL UNLESS COVER IS OPEN FOR A PERIOD TO ALLOW FRESH AIR TO ENTER BASIN. AN OUTSIDE BLOWER SHOULD BE USED TO PUMP CLEAN AIR INTO BASIN.

U.L. RECOMMENDS THE MAN IN BASIN HAVE ON A HARNESS WITH ROPE TO SURFACE SO THAT HE CAN BE PULLED OUT IN CASE OF ASPHYXIATION.

It is for this reason, Berkeley recommends the lift out check valve so that no service is required in the basin.

BEARINGS ARE DESIGNED FOR MINIMUM 50,000 HOURS B-10 LIFE.

SEAL FAILURE

All motors have a probe installed in seal chamber near the bottom so that any leakage past the lower seal into seal chamber is detected.

A red warning light at the control panel comes on if water enters seal chamber. This is an indicator only and does not stop motor, but warns that seal should be replaced within 2 to 3 weeks. **LONGER RUNNING WITHOUT SEAL REPLACEMENT COULD DAMAGE MOTOR. MOTOR MUST GO TO AUTHORIZED SERVICE STATION FOR SEAL REPLACEMENT.**

HEAT SENSOR

All motors have a heat sensing thermostat installed in top winding of motor. Any motor winding temperature above 248°F will open thermostat and stop motor. Thermostat will automatically reset as soon as it has cooled.

CAUTION: WITH AUTOMATIC RESET, MOTOR CAN START AT ANY TIME AFTER THERMOSTAT IS TRIPPED SO NEVER DO SERVICE WORK ON PUMP UNLESS POWER SUPPLY IS DISCONNECTED.

IMPORTANT: BE SURE HEAT SENSOR WIRES AND SEAL FAILURE WIRES ARE CONNECTED AT PANEL TERMINAL BLOCK. WARRANTY IS VOID IF WIRES ARE NOT CONNECTED OR ARE JUMPED.

MOTOR POWER CABLE AND CONTROL CABLE

Each pump motor is furnished with 25 feet of power and control cable. Longer lengths are available on request. Cord Size Table below.

Each power cord has 4 conductors - white, black, red and green. Interchanging any two leads reverses the motor.

The white and black leads connect to the two line terminals and the red connects to the start winding terminal. The green is for ground and must be connected to a good outside ground such as a water pipe or ground rod driven at least 8 feet in the ground.

The control cable has 5 conductors - black, white, red, orange and green. White and black connect to heat sensor terminals; red and orange connect to the seal failure terminals and green connects to the ground terminal.

APPLICATION

All Berkeley agricultural pumps can be used to pump raw sewage, storm water and other wastewater. **DO NOT USE FOR ACID WATER. MAXIMUM SOLID SIZE FOR ALL UNITS IS 3" DIAMETER.**

SINGLE PHASE MOTORS

Single phase motors are for 230 volts only. A special control panel with start and run capacitors and start relay are required for these pumps.

THESE CONTROL PANELS MUST BE OBTAINED FROM F.E. Berkeley OR MUST BE APPROVED BY Berkeley OR WARRANTY ON MOTOR IS VOID.

OIL FILLED

Motor chamber and seal chamber are oil filled for coolest running, best heat transfer and best lubrications for bearings and seals. Motor requires no oiling or greasing. Motor is sealed for life of bearings.

POWER CORD SIZES

Power cord size depends on motor HP size and voltage. See Cord Size Table below.

Motors are furnished for single voltage. See wiring diagrams Fig. 4.

CAUTION: NEVER PULL PUMP OR WORK ON CONTROL BOX UNTIL INCOMING POWER IS DISCONNECTED. NEVER RUN MOTOR UNTIL GREEN GROUND CONDUCTOR IS CONNECTED TO GOOD OUTSIDE GROUND AT CONTROL BOX.

CORD SIZE TABLE

Motor HP	Cable Size 230V
3	14
5	10

B-AG SERIES CONNECTION DIAGRAMS

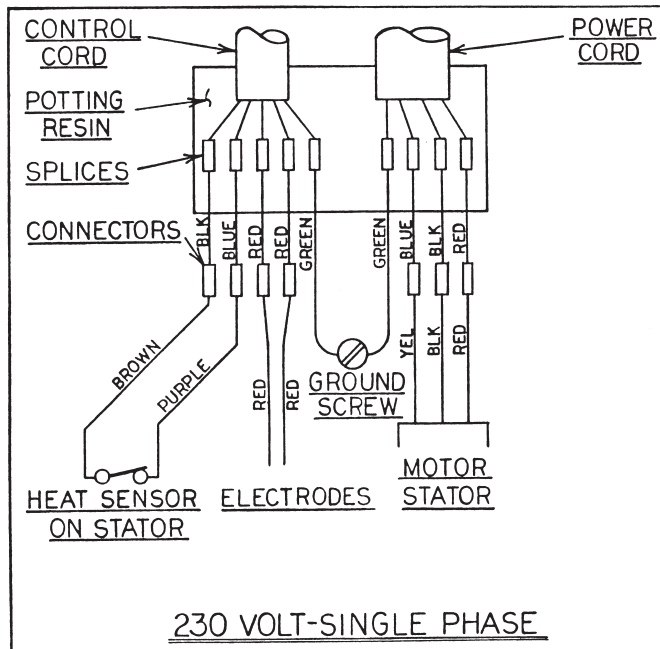

FIG. 4

CODE LETTER	LOCKED ROTOR KVA/HP
G	5.6 - 6.3
J	7.1 - 8.0

$$30 \text{ KVA/HP} = \frac{\text{LOCKED ROTOR AMPS} \times 1.73 \times \text{VOLTS}}{1000 \times \text{HP}}$$

$$10 \text{ KVA/HP} = \frac{\text{LOCKED ROTOR AMPS} \times \text{VOLTS}}{1000 \times \text{HP}}$$

MAKING ELECTRICAL CONNECTIONS

- Level controls are held by support bracket and cords are adjusted for proper depth.
 - Lower turnoff control should be set so that pump stops when water level is about at top of check valve or straight through casting.
 - Upper turn-on control is set to start pump when level is at height specified above pump.
 - Override control is set at height specified above upper turn-on control.
 - Alarm control is set about 6" to 12" above override control.
 - No control should be set above inlet invert.
- If control panel is mounted directly on basin top the power and control wires are taken directly to control box and are sealed in the cord plate with cord grip connectors.
- If panel is installed remote from basin the cords can be taken through a conduit to control panel, or junction box can be used in the basin to make connections. The Berkeley junction box has a built-in sealing connector to seal the outgoing wires. If other than Berkeley junction box is used a separate sealing connector must be used where wires leave the basin. See Wiring Diagrams Fig. 7,8,9.

CAUTION: IF CORDS ARE TAKEN DIRECTLY THROUGH A CONDUIT TO CONTROL BOX A SEAL FITTING MUST BE USED AT INLET OF CONDUIT TO PREVENT GAS VAPORS FROM GETTING TO CONTROL BOX. THIS TYPE OF INSTALLATION IS GENERALLY NOT RECOMMENDED BECAUSE THE SEALING CEMENT MUST BE BROKEN TO REMOVE A CORD. EXPLOSION PROOF -- SPECIAL INSTRUCTIONS ARE REQUIRED FOR EXPLOSION PROOF INSTALLATION. CONSULT FACTORY.

MOTOR

SINGLE PHASE MOTORS

Single phase pumps have only one rotation, and therefore, do not need to be checked.

WARRANTY IS VOID IF HEAT SENSOR AND SEAL FAILURE WIRES ARE NOT CONNECTED PROPERLY TO CONTROL BOX TERMINAL STRIP.

CAUTION: PUMP MOTOR IS NOT TO BE TAKEN APART IN THE FIELD. MOTORS UNDER WARRANTY MUST BE SERVICED BY Berkeley AUTHORIZED REPAIR STATION OR BE SENT TO FACTORY

50 CYCLE PUMPS

All Berkeley 60 cycle agricultural pumps can operate on 50 cycle power at reduced performance. See curve sheets. Single phase, 60 cycle, 230 volt pumps can operate on 220 volts, single phase, 50 cycle.

REMOVING PUMP CASE AND IMPELLER

In case of wear, damage due to dropping, plugged pump, or replacing a defective motor, the pump volute case and impeller can be removed in the field.

1. Remove bolts between seal housing flange and volute case. The motor and impeller can now be lifted off as a unit.
2. If necessary to remove impeller, lay pump on its side. With a screwdriver bend the tabs of the lockwasher away from the head of the hex head bolt.
3. Loosen and remove the bolt by turning counterclockwise. Since Loctite™ is used to secure the bolt and is applied to the shaft/impeller interface, heating of the shaft end to 450° to 500°F will usually be required.
4. Impeller is mounted by a straight fit with driving key. Pry evenly on opposite impeller sides with two large screwdrivers or small bars behind the impeller.
5. Set motor on end with shaft up after removing impeller so that oil will not drain past the seal.

REPLACING IMPELLER AND PUMP CASE

1. Apply Loctite™ #680: before assembly, in keyway, in the impeller bore (lower shaft O.D.), and on the threads of the hex head cap screw.
2. Before placing the impeller on the shaft, be sure the mechanical seal and its spring are in place.
3. Position retaining washer with long pin extension in keyway.
4. Obtain a new lockwasher and flatten two tabs located 180° from the locking projection on the inner edge of the washer. There should be one flattened tab on each side of the pin extending from the retaining washer.
5. Assemble hex head cap screw and tighten securely. Torque, using torque wrench, to values in table below.
6. Bend lockwasher tabs up against hex head on the bolt, do not bend up the two tabs flattened on each side of the pin in the retaining washer.

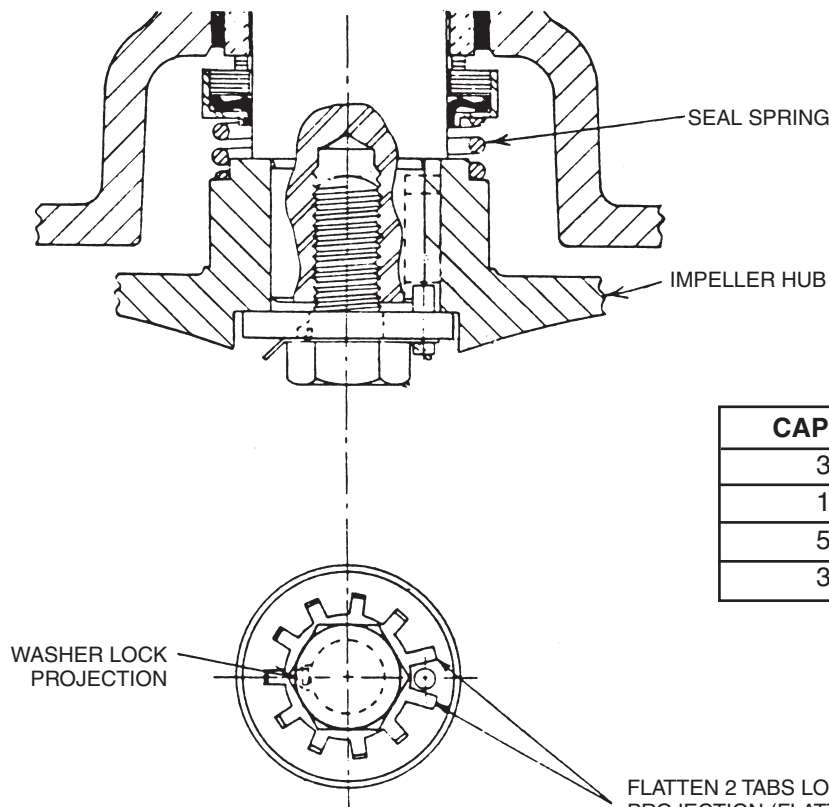

FIG. 2

CAP SCREW	TORQUE VALUE
3/8-16	20 ft.-lbs.
1/2-13	43 ft.-lbs.
5/8-11	93 ft.-lbs.
3/4-10	128 ft.-lbs.

FLATTEN 2 TABS LOCATED 180° FROM WASHER LOCKING PROJECTION (FLATTEN ONE ON EACH SIDE OF PIN).
AFTER ASSEMBLY OF HEX HEAD CAP SCREW, BEND REMAINING TABS AGAINST HEX HEAD.

Motor winding resistance, max. amps, locked rotor amps single phase motors

Catalog No.	Motor HP	RPM	Volts	Resistance in OHMS			Max. Amps	Locked Rotor Amps	Code Letter
				Black to White	Black to Red	White to Red			
B-AG3	3	1750	230	.83	2.38	3.21	17.5	96.0	J
B-AG5	5	1750	230	.45	2.12	2.57	34.0	136.0	G

INSTALLATION AND SERVICING INSTRUCTIONS FOR SUBMERSIBLE MOTORS USED IN HAZARDOUS LOCATIONS

Class 1, Div. 1, Group D

WARNING: MOTORS TO BE USED WITH PUMPS HANDLING AGRICULTURAL SEWAGE AND WASTE WATER ONLY. DO NOT USE IN OTHER HAZARDOUS LIQUIDS.

MOTOR REPAIR: MOTORS MUST BE REPAIRED AND SERVICED ONLY AT Berkeley AUTHORIZED SERVICE CENTERS OR AT THE Berkeley FACTORY. ANY UNAUTHORIZED FIELD REPAIR VOIDS WARRANTY.

GENERAL

Motor construction meets the Underwriters Laboratories requirements for Class 1, Group D hazardous service. Fig. 3 shows the motor sectional drawing with principal parts called out. Motor chamber and seal chamber are oil filled for heat transfer and for lubrication of bearings and seals. Internal motor connection diagrams are shown in Fig. 4. A high dielectric oil is used and does not require replacement in normal use. Air space is provided above oil level in seal chamber and motor chamber for expansion of the oil on heating. Power lines and control lines are sealed in motor cap with epoxy potting resin.

MOTOR OVERHEAT PROTECTION

Each motor is provided with heat sensor thermostats attached directly to the motor winding. Single phase units use one thermostat. The thermostat is made by Texas Instrument Co. Model #9700K-36-173 and is set to trip at a motor winding temperature of 230°F (110°C). The max. contact rating is 18 amps at 115V AC and 12 amps at 230V AC.

The thermostat is connected in series with the coil of a holding relay that will open a set of normally closed contacts which are in series with the motor control contactor when the motor overheats. When the motor is stopped due to an overheated condition it will not start until manually reset by pushing the heat sensor reset button on the front of the control panel.

Complete wiring diagrams Figs. 5, 6 show how the sensor is connected.

SEAL FAILURE

The oil filled seal chamber is provided with moisture sensing probes to detect water leakage through the lower shaft seal.

Water in the seal chamber energizes a red seal leak warning light at the control panel. This is a warning light only and does not stop motor but indicates that seal has leaked and must be repaired within two to three weeks. If motor is allowed to operate too long after warning, upper seal may leak and allow water to enter motor chamber causing motor failure.

The seal leak warning light can also indicate moisture in the motor chamber as moisture probe wires are exposed in this chamber. In case warning light comes on motor should be stopped immediately and the motor power lines must be checked for any resistance to ground using an ohmmeter or megger.

The seal leak test switch tests the seal leak circuit continuity, when pushed the seal leak test bulb should light. If the test bulb does not light it means either the wiring circuitry to the seal leak electrodes in the pump has been broken or the seal leak warning indicator bulb and/or seal leak test bulb has failed.

If resistance is above (one Megohm) the leakage is in seal chamber only. If motor shows below (one Megohm) unit must be removed from service immediately and be serviced at authorized service center.

Connection diagrams for the seal failure probes is shown on Figs. 4, 5.

ELECTRICAL MOTOR CONTROLS

CAUTION: All electrical controls and motor starting equipment must be as specified in these instructions and must be installed outside the hazardous area unless approved explosion proof controls are used.

Level sensing controls in the sump or hazardous area must be of an approved type for hazardous locations or must be of the intrinsically safe type which requires the use of special relays to limit current and voltage to approved levels.

MOTOR INSPECTION AND SERVICE

Motor chamber and seal chamber are oil-filled for lubrication of the bearings and seals and do not require service. Seal failure signal light indicates water in the seal chamber or motor chamber and should be checked as explained above.

Motor should be checked at least four times a year for ground leakage and proper amps draw.

In checking motor for grounds, disconnect all line leads from control terminal block and use ohmmeter or megger to check resistance to ground of each line lead.

If resistance reading is less than one Megohm, unit should be removed for service at a Berkeley authorized service center.

Use clamp-on ammeter to check power draw. Max. amps should be within nameplate rating.

SINGLE PHASE CONTROLS

Single phase motors are of the capacitor start, capacitor run type so proper start and run capacitors and start relays must be used in the control box. Wiring diagrams Figs. 5 and 6 show proper connections.

CAUTION: All electrical controls must be installed outside the hazardous area unless of an approved type for hazardous locations.

INSTALLATION

Motor must be installed using rigid conduit to meet Class 1, Division 1 requirements of the National Electrical Code.

Conduit must be stainless steel or of coated metal conduit resistant to sewage water.

An explosion-proof junction box with approved conduit seal, where conduit leaves the hazardous area, must be used to make power and control connections for motor.

Level controls must be of an approved type for hazardous locations or must be of the intrinsically safe type.

Intrinsically safe controls can be cord connected.

Other approved controls not intrinsically safe must be connected to junction box with conduit of M.I. cable.

PUMP DIMENSIONS

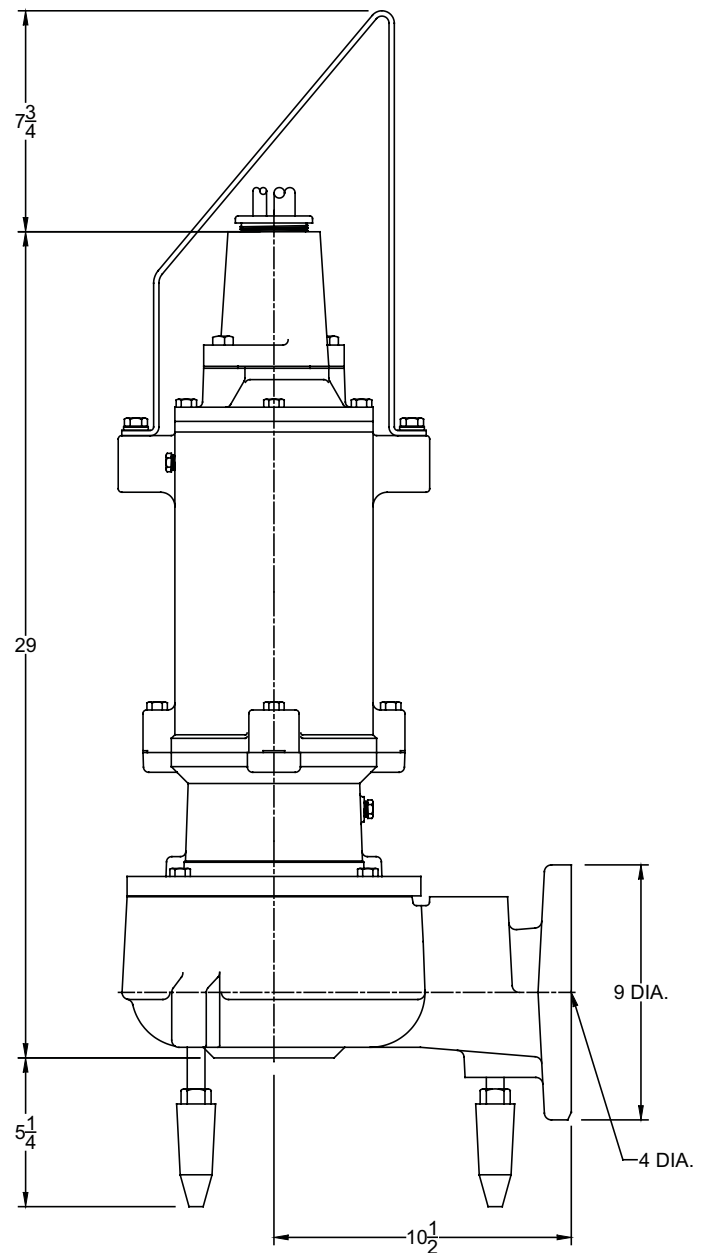

B-AG SERIES

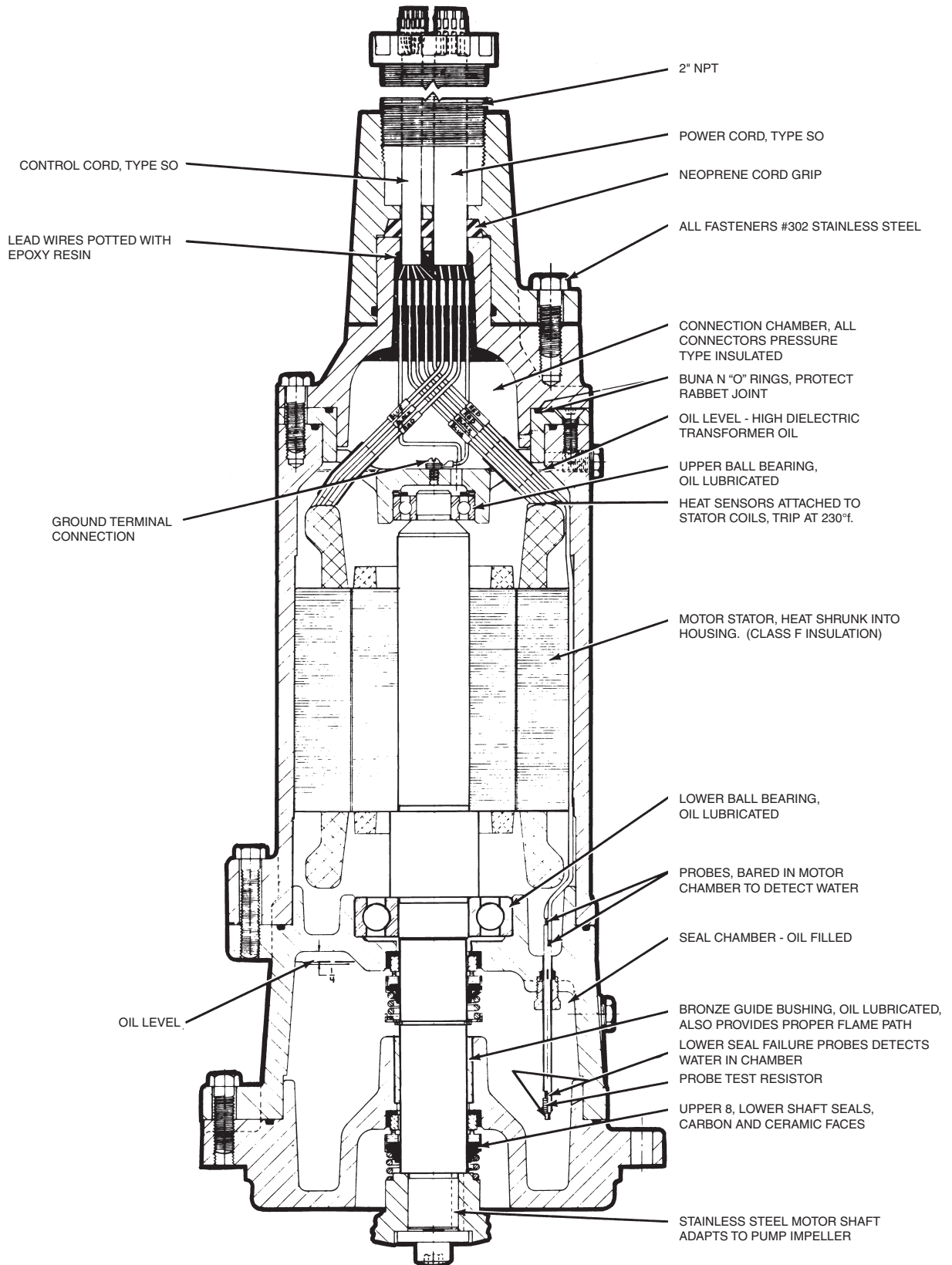

FIG. 3

CHECKING FOR MOISTURE IN MOTOR

Use ohmmeter and set on highest scale. Readings on the large power cord between any of the conductors red, black, white to green conductor or motor housing should be more than 500,000 ohms. Motor probably will run with a lower reading, but if pump is out of service and reading is below 500,000 ohms the motor housing and stator should be removed and baked in a drying oven at 220°F. To be serviced only at authorized service station.

Readings should be taken with line leads disconnected from terminal strip.

RESISTANCE OF WINDINGS

Every motor winding has a fixed resistance. Winding must check close to the values given in tables to operate properly. This winding resistance also shows if motor is connected for voltage being used.

Use ohmmeter for this test and set on scale to read directly in ohms.

TROUBLE CHECK LIST

Troubles listed are generally caused by the pump. Other trouble can occur from faulty control box operation - these will be listed with the control box instructions.

CONDITION

Pump runs but does not pump liquid from basin

PROBABLE CAUSE

1. Pump impeller may be air locked, this occasionally occurs on a new installation, see page 3. Start and stop pump several times to purge air. Be sure air vent hole in volute case is clean.
2. Run additional water into basin so that pump will be submerged deeper to clear air.
3. If pump is three phase, rotation may be wrong. See instructions for checking proper rotation.
4. If pump has been installed for some time and does not pump, it may be clogged at inlet.
5. Discharge gate valve may be closed.
6. Discharge check valve may be clogged or have a broken clapper or spring.
7. Discharge head may be too high. Check elevation. Maximum pump head at zero flow is shown on pump curve sheet.
8. If above checks do not locate trouble, motor rotor may be loose on shaft which allows motor to run but will not turn impeller or only at low RPM.

Red Light comes on at control box.

This indicates some water has leaked past the lower seal and has entered the seal chamber and made contact with the electrode probe. Pump must be removed from basin within approximately two (2) weeks for replacement of lower seal. This preventative repair will save an expensive motor.

CONDITION

Overload trips at control box and alarm buzzer or flashing red light comes on due to high water level in basin

PROBABLE CAUSE

1. Push in on red reset button to reset overload. If overload trips again after short run pump has some damage and must be removed from basin for checking.
2. Trouble may be from clogged impeller causing motor to overload or could be from failed motor.
3. Trouble may be from faulty component in control box. Always check control box before removing pump.

Yellow run light stays on continuously

1. Indicates H-O-A switch may be in the hand position.
2. Level control switch may have failed causing pump to continue to operate when water is below lower control.
3. Impeller may be partially clogged causing pump to operate at very reduced capacity.
4. Gate valve or check valve may be clogged causing low pump flow.
5. Pump may be air logged.

Circuit breaker trips

1. Reset breaker by pushing clear down on handle then back to on position. If breaker trips again in few seconds it indicates excessive load probably caused by a short in the motor or control box. Check out instructions given with control box before pulling pump.
2. If this condition happens after an electrical storm, motor or control box may be damaged by lightning.
3. Resistance reading of the motor with lead wires disconnected from the control box can determine if trouble is in motor or control box.

Pump is noisy and pump rate is low

1. Impeller may be partially clogged with some foreign objects causing noise and overload on the motor.
2. Impeller may be rubbing on wear ring due to dent shaft or misalignment.
3. Pump may be operating too close to shut-off. Check head.

Grease and solids have accumulated around pump and will not pump out of basin

1. Lower control switch may be set too high.
2. Run pump on hand operation for several minutes with small amount of water running into basin to clean out solids and grease. This allows pump to break suction and surge which will break up the solids. If level switch is set properly this condition generally will not occur.
3. Trash and grease may have accumulated around floats causing pump to operate erratically.

IN SUMP CONNECTION BOX, SIMPLEX SYSTEM, FLCW 3 BALL CONTROL

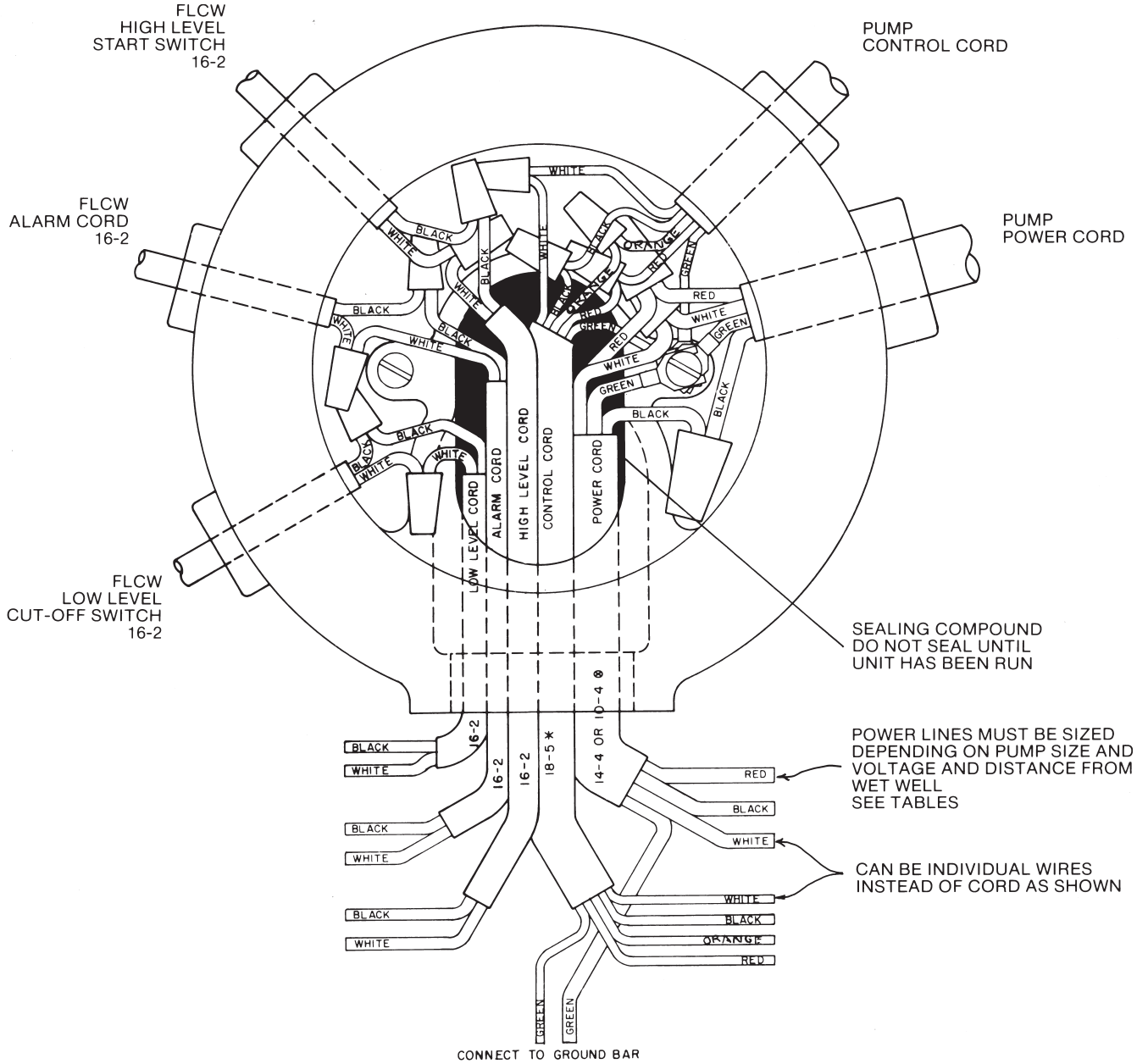

* GAGE DEPENDS ON HOREPOWER OF PUMP

FIG. 7

IN SUMP CONNECTION BOX, DUPLEX SYSTEM, FLCW 4 BALL CONTROL

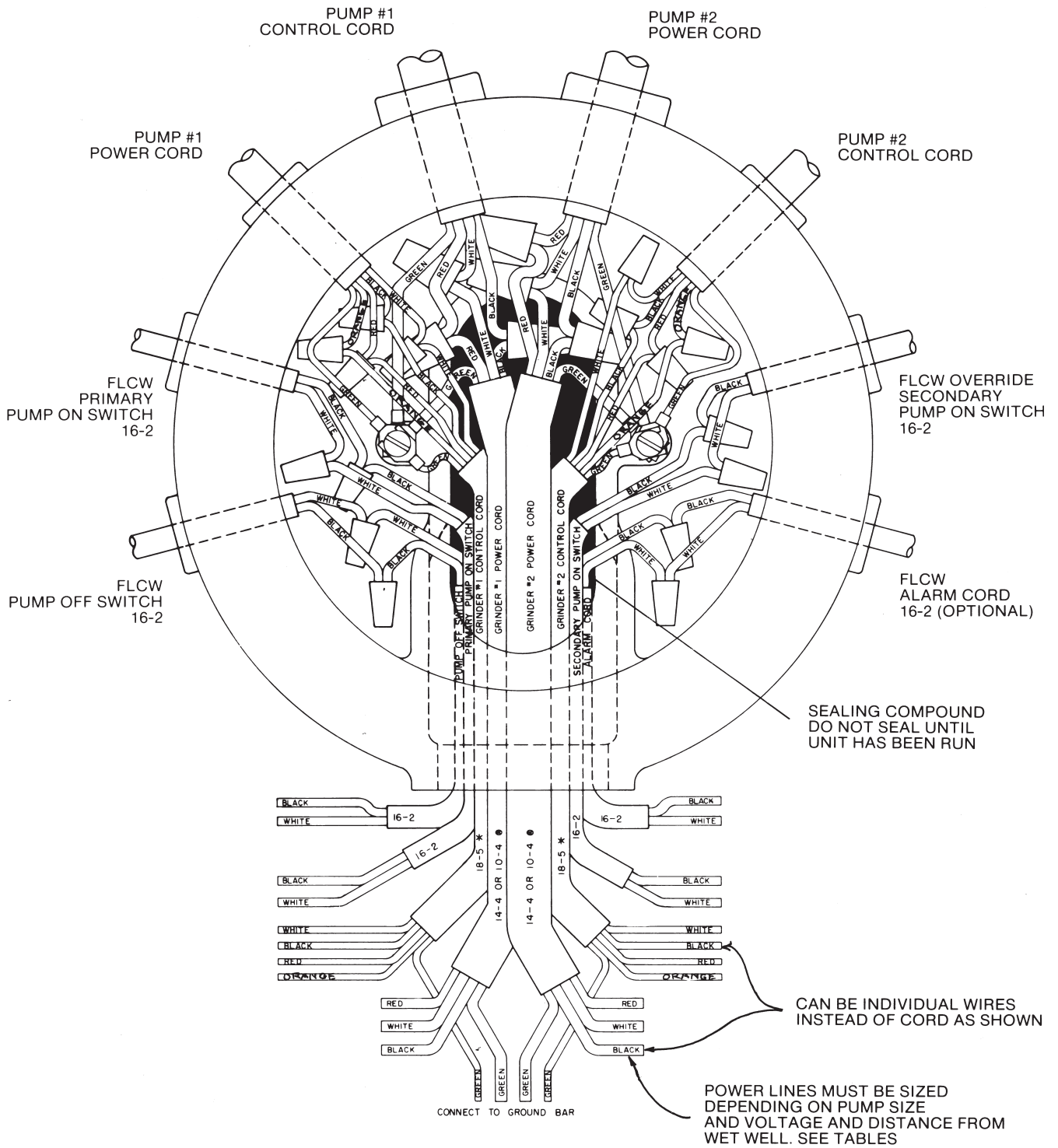

* GAGE DEPENDS ON HOREPOWER OF PUMP

FIG. 8

WIRING DIAGRAM

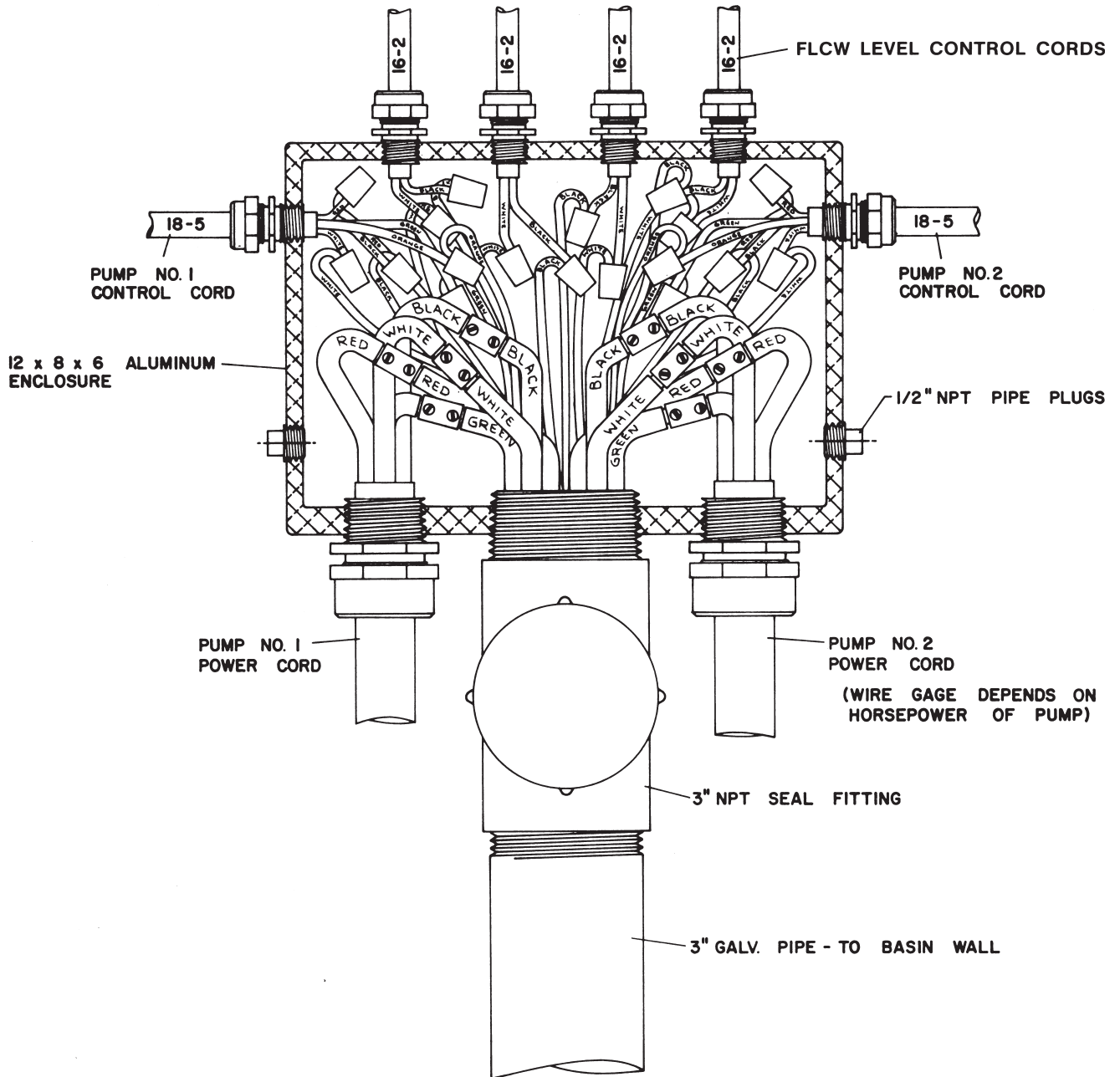

FIG. 9

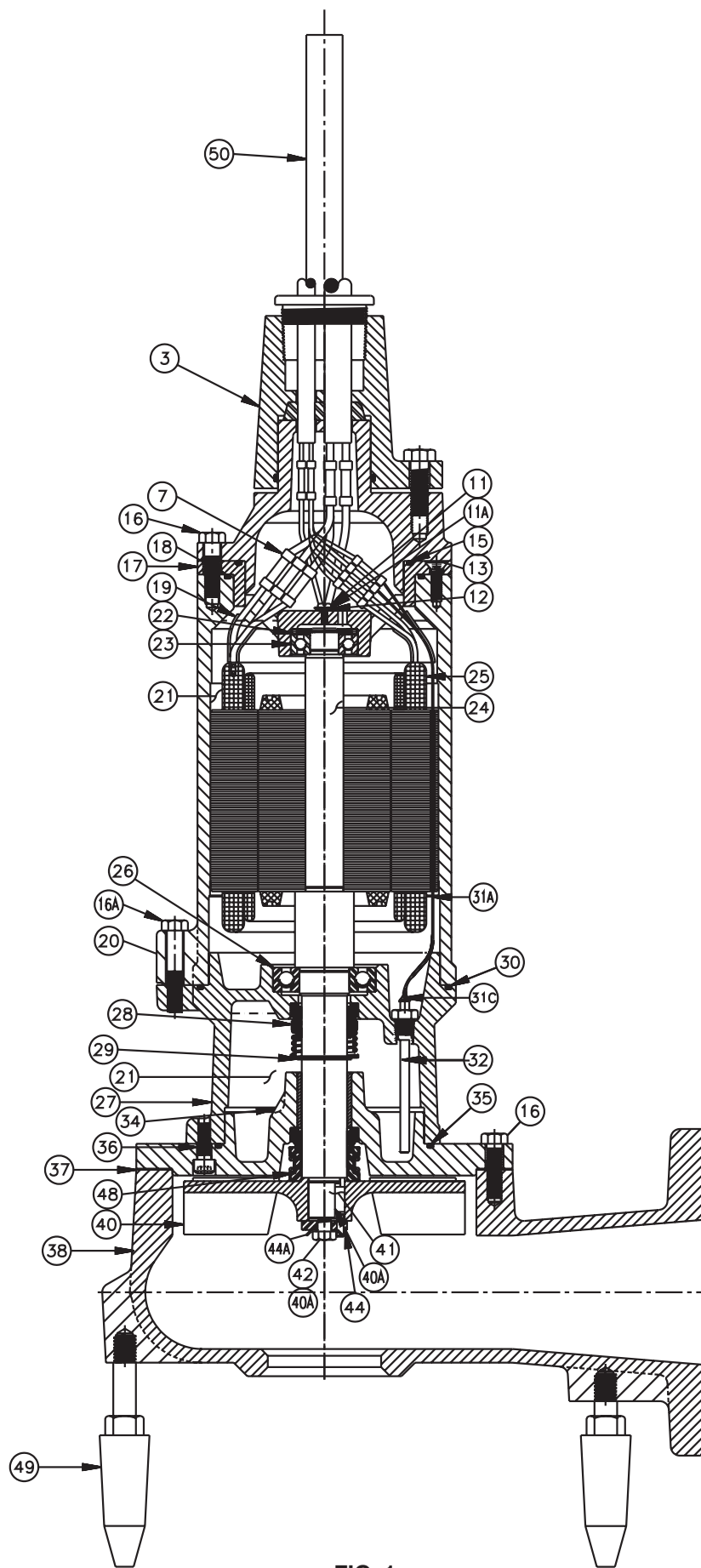

FIG. 1

B-AG SERIES 3-5 HP REPAIR PARTS LIST

Ref. No.	Description	No. Req'd	Part Numbers
3	Cord Cap Complete - 25' Wires	1	22569B010
7	Connector	3	15781A007
11	Mach. Screw, #10-24 x $\frac{3}{8}$ " Lg.	1	5434A043
11A	Washer, $\frac{7}{16}$ " x $\frac{13}{64}$ " x $\frac{1}{32}$ "	1	5030A126
12	Lockwasher, #10	1	6107A015
13	Mach. Screw, Socket Flat Hd., $\frac{5}{16}$ "-18 x 1"	2	7597A017
15	"O" Ring, $4\frac{7}{8}$ " x $4\frac{5}{8}$ " x $\frac{1}{8}$ "	1	5876A123
16	Cap Screw, Hex Hd., $\frac{7}{16}$ "-14 x $1\frac{1}{2}$ "	8	19102A006
16A	Cap Screw, Hex Hd., $\frac{7}{16}$ "-14 x $2\frac{1}{4}$ "	4	19102A023
17	Cap, Upper Bearing	1	22590B000
18	"O" Ring, $5\frac{1}{2}$ " x $5\frac{1}{4}$ " x $\frac{1}{8}$ "	1	5876A112
19	Tube, Plastic, $1\frac{1}{4}$ " Lg.	2	10649A102
19	Tube, Plastic, 3" Lg.	2	10649A116
20	Housing, Motor	1	22571D*
21	Oil, Transformer (5 gal. can)	1.6 gal	11009A006K
22	Washer, Finger Spring	2	19331A006
23	Bearing, Ball	1	8565A022
24	Rotor w/Shaft	1	22846C100
24	Shaft only	1	22848C100
25	Stator (B-AG3)	1	24407C000
25	Stator (B-AG5)	1	24407C004
26	Bearing, Ball	1	8565A023
27	Housing, Seal, Upper	1	22576D000
28	Seal, $1\frac{1}{4}$ " Shaft (upper)	1	22577A000

Ref. No.	Description	No. Req'd	Part Numbers
29	Ring, Retaining	1	12558A008
30	"O" Ring, 7" x $6\frac{3}{4}$ " x $\frac{1}{8}$ "	1	5876A114
31	Electrode, Wire	2	22578A000
31A	Wire, Electrode	2	22578A100
31C	Screw, Machine	2	05434A025
32	Probe, Seal Leak	2	25343A100
34	Housing, Lower Seal w/Bearing	1	22853C001
35	"O" Ring, 6" x $5\frac{3}{4}$ " x $\frac{1}{8}$ "	1	5876A113
36	Cap Screw, Socket Hd., $\frac{3}{8}$ "-16 x 1"	4	6106A28
37	Gasket, Vellumoid	1	5231A079
38	Case, Volute	1	22854D001
40	Impeller (B-AG3)	1	22855C010
40	Impeller (B-AG5)	1	22855C020
40A	Sealant, Loctite Grade 680	2	14550A009
41	Key, $\frac{1}{4}$ " Square x $1\frac{1}{16}$ " Lg.	1	05818A074
42	Cap Screw, Hex Hd., $\frac{3}{8}$ "-16 x $1\frac{1}{4}$ "	1	19101A017
44	Washer, Impeller Retainer w/Pin	1	23609A001
44A	Washer, Bearing Lock	1	08001A007
48	Seal, $1\frac{1}{4}$ " Shaft (lower)	1	27067A001
49	Support Leg-625	1	23768A020
50	Bail, Lifting, Complete	1	25371A010
	Bail, Lifting	1	25371B000
	Washer, Lock $\frac{1}{2}$ "	2	05484A016
	Hex Screw, $\frac{1}{2}$ " x $1\frac{1}{4}$ "	2	19103A052

PUMP MODELS

These instructions cover the installation of the B-AG3 and B-AG5 series of agricultural pumps. All models are designed for handling raw agricultural sewage and waste water. Do not use for acid waste water.

The B-AG3 and B-AG5 series are made with a recessed impeller. All models will pass 3" diameter solids and have a 4" standard flange discharge.

VOLTAGES

All single phase motors are for 230 volts only.



Sta-Rite Industries
293 Wright Street , Delavan, WI 53115
Phone: 800-472-0884
Fax: 800-390-5351
www.berkeleypump.com