



PENTAIR BERKELEY*

**STAINLESS STEEL SUBMERSIBLE PUMPS
6TS SERIES**



KIT PROGRAM

pentair.com

TABLE OF CONTENTS

SECTION	PAGE
MIXED FLOW COMPONENT KITS - 115, 155, 230 AND 300 SERIES	4-7
Suction Bracket Kit	5
First-Stage Kit	5
Intermediate Stage Kit.....	6
Shaft/Strap/Cable-Guard Kit	6
Discharge Kit	7
SPACER CHARTS - MIXED FLOW	8-9
First-Stage Kit - Mixed Flow.....	8
Intermediate-Stage Kit - Mixed Flow	9
MODEL 6TS-115 SERIES	10-14
115 Series Performance Curves.....	10-12
115 Series Build Charts & Cutoff Chart.....	13-14
MODEL 6TS-155 SERIES	15-19
155 Series Performance Curves	15-17
155 Series Build Charts & Cutoff Chart	18-19
MODEL 6TS-230 SERIES	20-24
230 Series Performance Curves	20-22
230 Series Build Charts & Cutoff Chart	23-24
MODEL 6TS-300 SERIES	25-29
300 Series Performance Curves	25-27
300 Series Build Charts & Cutoff Chart	28-29
ASSEMBLY.....	30-40
Assembly Instructions Step-by-Step - Mixed Flow	30-33
Pump Assembly	34-37
MODEL 6TS-115 Series	34
MODEL 6TS-155 Series	35
MODEL 6TS-230 Series.....	36
MODEL 6TS-300 Series	37
Assembly Instructions - Shaft.....	38
Assembly Instructions - Strap.....	39-40
REPAIR PARTS LIST	41

STAINLESS STEEL SUBMERSIBLE PUMPS

60 Hz | 1 - 60 HP | 0.7 - 44.5kW

Mixed Flow Series 115 | 155 | 230 | 300

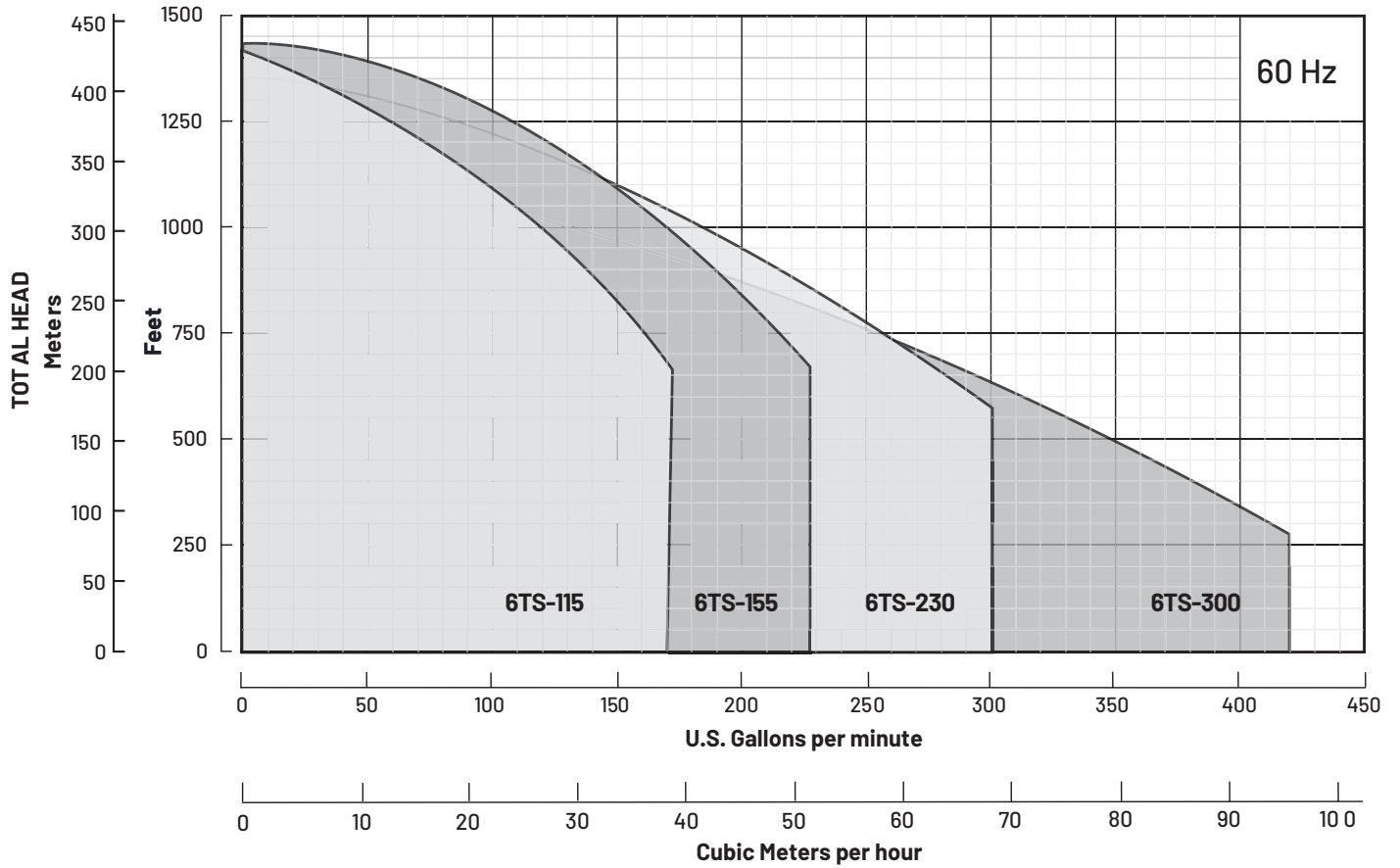

MIXED FLOW COMPONENT KITS – 115, 155, 230 AND 300 SERIES

Suction Bracket Kit

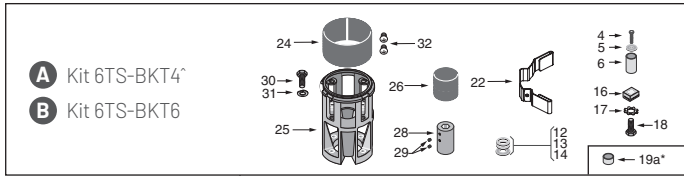

*BKT4 includes additional 17.04 mm spacer #19a (M14054); needed due to bracket length difference versus BKT6.

First-Stage Kit

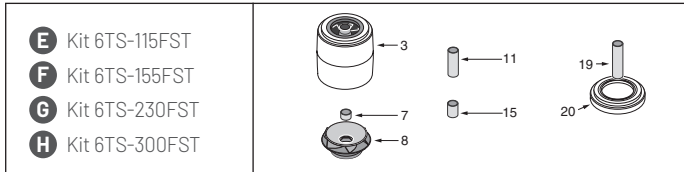

Intermediate-Stage Kit

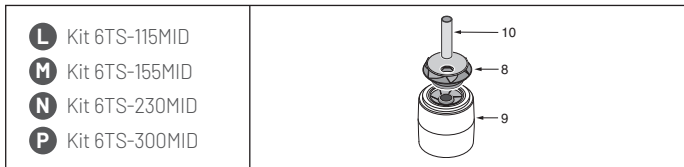

Shaft / Strap / Cable-Guard Kit

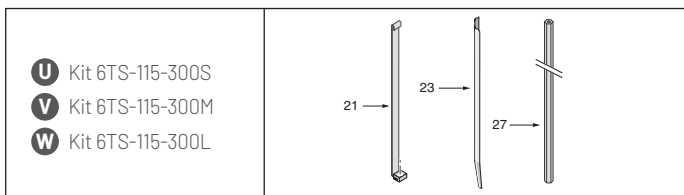

Discharge Kit



Brand Labeling Kit

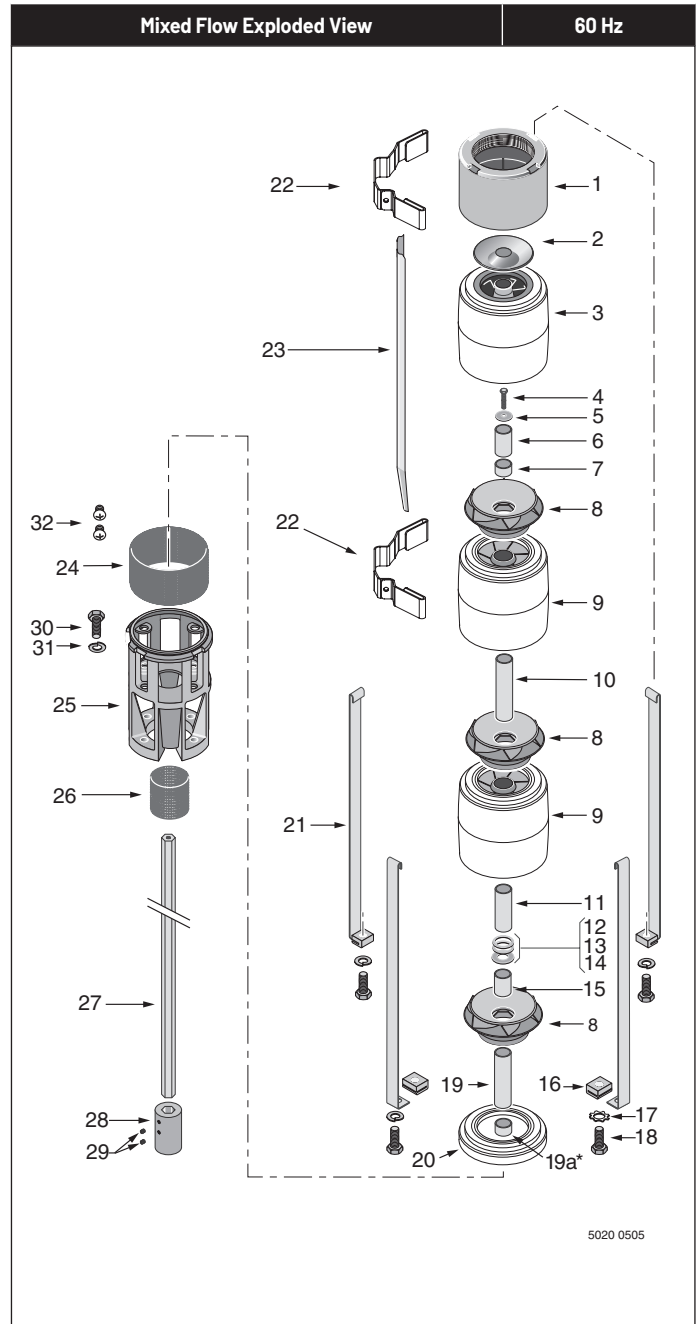
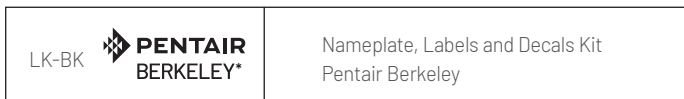

5020 0505

Key No.	Part Description	Key No.	Part Description	Key No.	Part Description
1.	Discharge	13.	Fiber Washer	23.	Cable Screen
2.	Check Valve Poppet	14.	Thrust Washer	24.	Suction Screen
3.	Top Bowl	15.	Thrust Shaft Spacer	25.	Suction Bracket
4.	Stack Compression Capscrew	16.	Strap Nut	26.	Coupling Guard
5.	Stack Compression Washer	17.	Star Lock Washer	27.	Shaft
6.	Bearing Journal	18.	Strap Capscrew	28.	Coupling
7.	Discharge Shaft Spacer	19.	Inlet Shaft Spacer	29.	Coupling Set Screws
8.	Impeller	19a.	Inlet Shaft Spacer-17.04mm	30.	Hex Bolts
9.	Bowl w/Diffuser	20.	First Stage Adapter	31.	Split Washers
10.	Stage Spacer	21.	Strap	32.	Screws – Suction Screen
11.	Distance Sleeve	22.	Cable Guard Bracket		
12.	Stainless Washer				

MIXED FLOW COMPONENT KITS – 115, 155, 230 AND 300 SERIES

Suction Bracket Kit

60 Hz

Mixed Flow	Dia.	Motor HP	Motor kW	Mixed Flow Rate Series				
				115	155	230	300	
A Kit 6TS-BKT4 [*] B Kit 6TS-BKT6	4"	1	0.7	-	-	-	-	
		1.5	1.1	Kit A	-	-	-	
2		1.5	-		-	-		
3		2.2	-		-	-		
5		3.7	Kit A		Kit A	Kit A	-	
7.5		5.6	Kit A		Kit A	Kit A	-	
10	7.5	Kit A	Kit A		Kit A	Kit A		
	6"	5	3.7	Kit B	Kit B	Kit B	Kit B	
		7.5	5.6					
		10	7.5					
		15	11.2					
		20	14.9					
		25	18.6					
		30	22.4					
		40	29.8					
		50	37.3					-
		60	44.7					-

^{*}BKT4 includes additional 17.04mm spacer #16a and #19a (M14054); needed due to bracket length difference versus BKT6.
^{**}BKT4 does not include coupling screen #26, as it is not needed.

First-Stage Kit

60 Hz

Mixed Flow Kit	Motor HP	Motor kW	Mixed Flow Rate Series				
			115	155	230	300	
E Kit 6TS-115FST F Kit 6TS-155FST G Kit 6TS-230FST H Kit 6TS-300FST	1	0.7	-	-	-	-	
	1.5	1.1	Kit E	-	-	-	
	2	1.5		-	-	-	
	3	2.2		-	-	-	
	5	3.7		-	-	-	
	7.5	5.6		-	-	-	
	10	7.5		-	-	-	
	15	11.2		Kit F	Kit G	Kit H	-
	20	14.9		Kit F	Kit G	Kit H	-
	25	18.6		Kit F	Kit G	Kit H	-
	30	22.4		Kit F	Kit G	Kit H	-
	40	29.8		Kit F	Kit G	Kit H	-
	50	37.3		-	-	-	-
	60	44.7		-	-	-	-

MIXED FLOW COMPONENT KITS – 115, 155, 230 AND 300 SERIES

Intermediate-Stage Kit

60 Hz

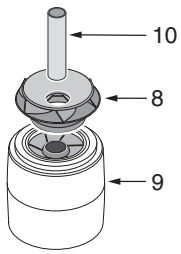
Mixed Flow Kit	Motor HP	Motor kW	Mixed Flow Rate Series			
			115	155	230	300
<p> L Kit 6TS-115MID M Kit 6TS-155MID N Kit 6TS-230MID P Kit 6TS-300MID </p> 	1	0.7	-	-	-	-
	1.5	1.1	Kit L	-	-	-
	2	1.5		-	-	-
	3	2.2		-	-	-
	5	3.7		Kit M	Kit N	Kit P
	7.5	5.6				
	10	7.5				
	15	11.2				
	20	14.9				
	25	18.6				
	30	22.4		-	-	-
	40	29.8	-	-	-	
	50	37.3	-	-	-	
	60	44.7	-	-	-	

Shaft/Strap/Cable-Guard Kit

60 Hz

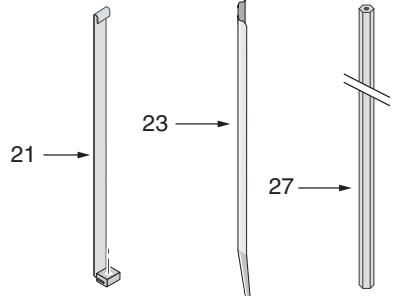
Mixed Flow Kit	Motor HP	Motor kW	Mixed Flow Rate Series			
			115	155	230	300
<p> U Kit 6TS-115-300S V Kit 6TS-115-300M W Kit 6TS-115-300L </p> 	1	0.7	-	-	-	-
	1.5	1.1	-	-	-	-
	2	1.5	Kit U	-	-	-
	3	2.2		-	-	-
	5	3.7		Kit V	Kit U	Kit U
	7.5	5.6				
	10	7.5				
	15	11.2				
	20	14.9				
	25	18.6				
	30	22.4		Kit W	Kit V	Kit V
	40	29.8				
	50	37.3	-			
	60	44.7	-	-	-	

MIXED FLOW COMPONENT KITS – 115, 155, 230 AND 300 SERIES

Discharge Kit

60 Hz

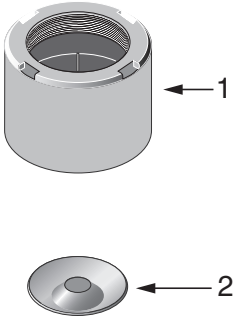
Mixed Flow Kit	Discharge	Motor HP	Motor kW	Mixed Flow Rate Series			
				115	155	230	300
<ul style="list-style-type: none"> Y Kit 6TS-D3NPT Y1 Kit 6TS-D3BSP Z Kit 6TS-D4NPT Z1 Kit 6TS-D4BSP 	3"	1	0.7	-	-	-	-
		1.5	1.1	Kit Y	-	-	-
		2	1.5		Kit Y1	-	-
		3	2.2			-	-
		5	3.7			-	-
		7.5	5.6			-	-
		10	7.5	-		-	
		15	11.2	-	-		
		20	14.9	-	-		
		25	18.6	-	-		
		30	22.4	-	-		
		40	29.8	-	-		
		50	37.3	-	-		
		60	44.7	-	-		
			4"	5	3.7	-	-
7.5	5.6			-	-		
10	7.5			-	-		
15	11.2			-	-		
20	14.9			-	-		
25	18.6			-	-		
30	22.4			-	-		
40	29.8			-	-		
50	37.3			-	-		
60	44.7			-	-		

Note: 3" and 4" Discharge are interchangeable within flow series. Chart reflects "recommended" use of discharge size with flow series.

SPACER CHART – MIXED FLOW

First-Stage Kit – Mixed Flow

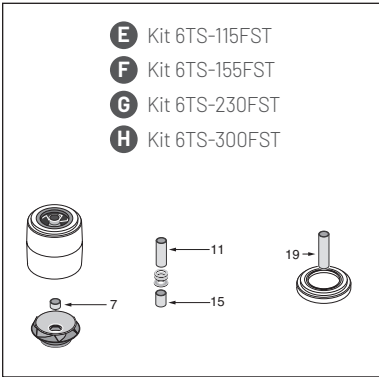

First Stage Kit	Mixed Flow - in. (mm)							
	Part Number	E 115 Length	Part Number	F 155 Length	Part Number	G 230 Length	Part Number	H 300 Length
#7 Disch Shaft Spacer	M14049	.62(15.74)	M14054	.67(17.04)	M14061	.58(14.66)	M14068	.40(10.16)
#11 Distance Spacer	M14048	2.89(73.56)	M14053	2.84(72.26)	M14060	2.96(75.10)	M14067	3.39(86.15)
#15 Thrust Shaft Spacer	M14047	1.36(34.44)	M14052	1.41(35.74)	M14059	1.30(32.90)	M14066	.86(21.85)
#19 Inlet Spacer 6" Motor [^]	M15679	3.07(77.95)	M15680	3.02(76.65)	M15681	3.12(79.24)	M15682	3.30(83.75)

[^]NOTICE: The inlet shaft spacers (item 19) in First Stage Kits are not interchangeable with the inlet shaft spacers on the 6TS Wholegoods made in Kansas City.

#7 Discharge Shaft Spacer

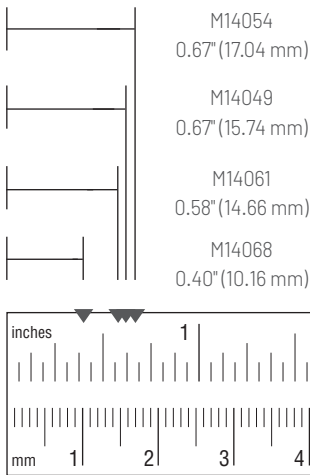

#11 Distance Spacer

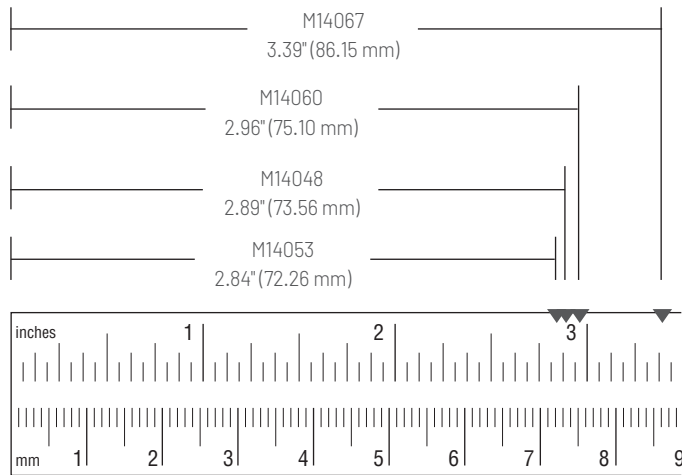

#15 Thrust Shaft Spacer

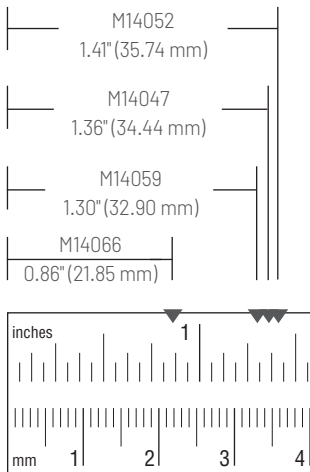

#19 Inlet Spacer

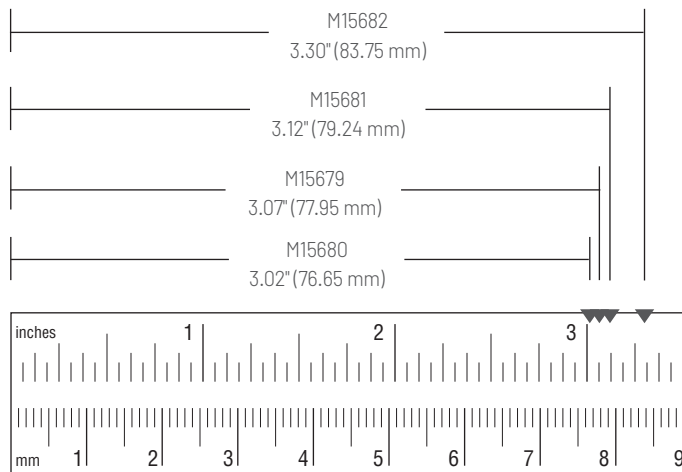

SPACER CHART – MIXED FLOW

Intermediate-Stage Kit – Mixed Flow

L Kit 6TS-115MID
M Kit 6TS-155MID
N Kit 6TS-230MID
P Kit 6TS-300MID

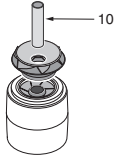

Intermediate Stage Kit	Mixed Flow - in. (mm)							
	Part Number	L 115 Length	Part Number	M 155 Length	Part Number	N 230 Length	Part Number	P 300 Length
#10 Stage Spacer	M14071	4.37 (111)	M14071	4.37 (111)	M14071	4.37 (111)	M14071	4.37 (111)

#10 Stage Spacer



Suction Bracket Kit – Mixed Flow

M Kit 6TS-BKT4
 ← 19a

BKT4 includes additional 17.04 mm spacer #19a (M14054); needed due to bracket length difference versus BKT6.

#19a Inlet Shaft Spacer

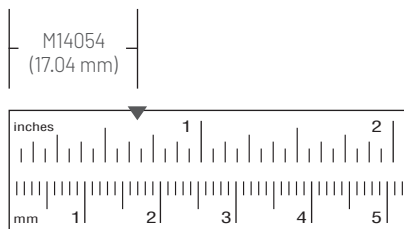

MODEL 6TS-115 SERIES

Series Name: 6TS-115

Pump Size: 6TS-115

Department of Energy Requirements		Available Configurations		Curve Conditions	
PEI _{CL}	0.95	Submersible Turbine	6TS-115	Nominal RPM	3475
Model	6TS-115			Maximum Working Pressure	650 PSI (44.8 BAR)
Imp. Dia. (in.)	4.134			Based on Fresh Water @ F	68

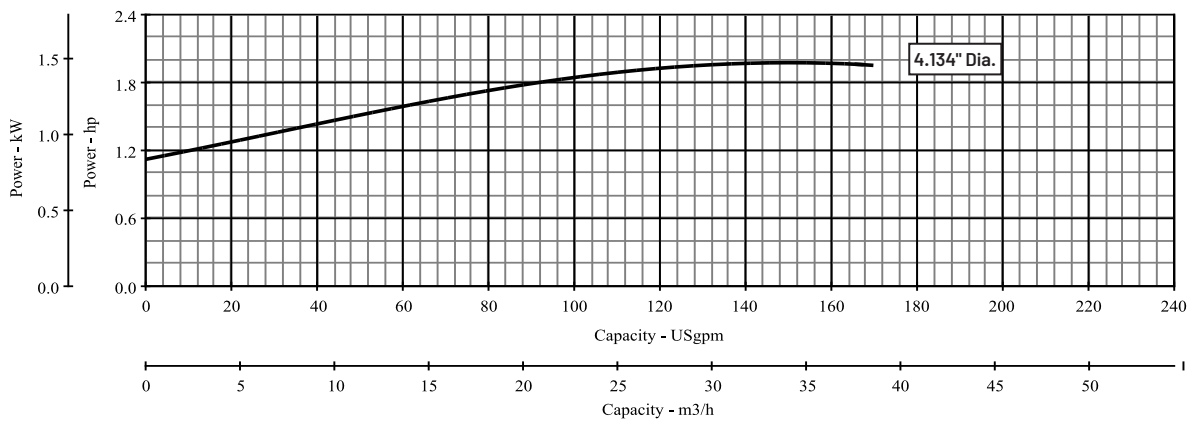
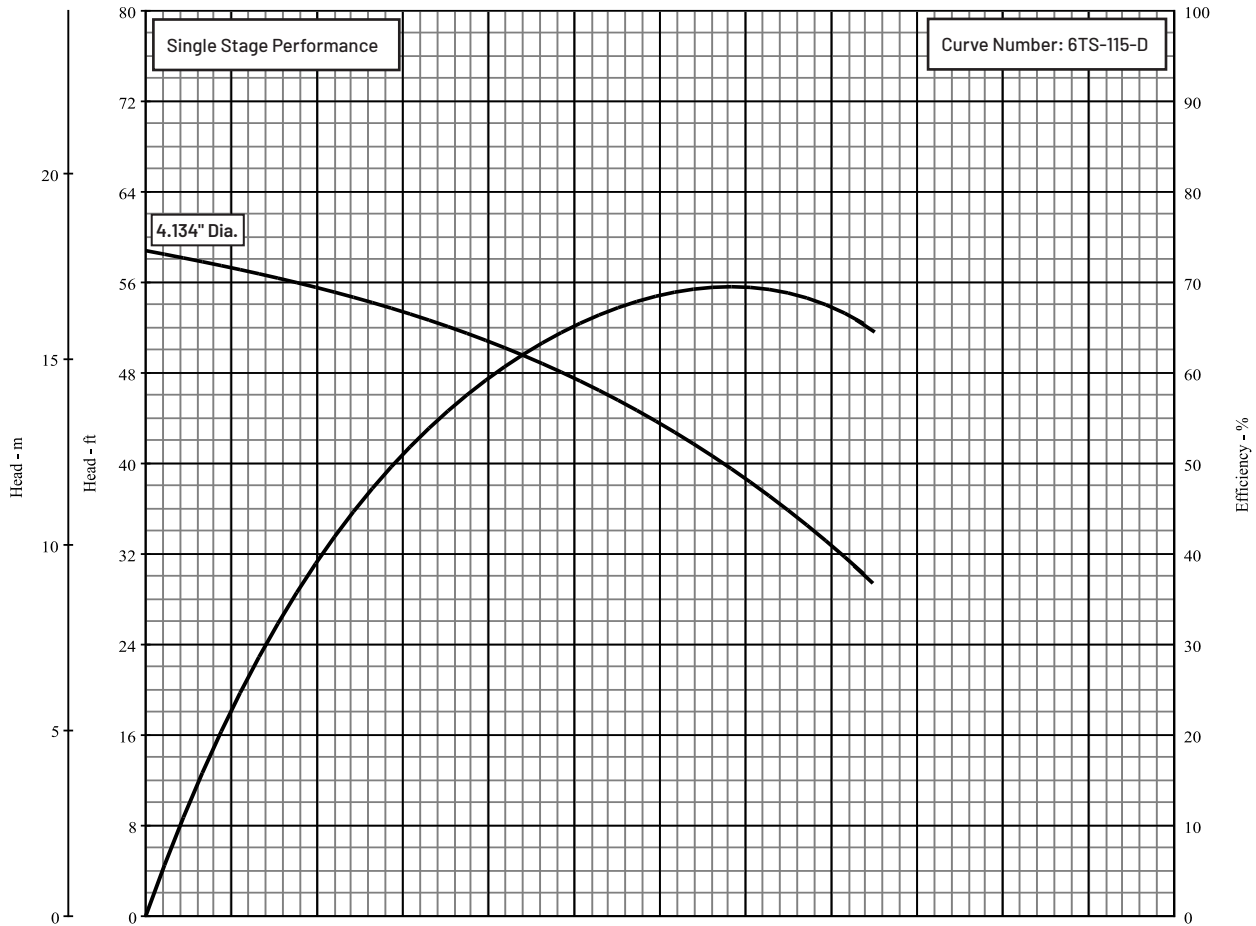

MODEL 6TS-115 SERIES

Series Name: 6TS-115

Pump Size: 6TS-115

Department of Energy Requirements		Available Configurations		Curve Conditions	
PEI _{CL}	0.95	Submersible Turbine	6TS-115	Nominal RPM	3475
Model	6TS-115			Maximum Working Pressure	650 PSI (44.8 BAR)
Imp. Dia. (in.)	4.134			Based on Fresh Water @ F	68

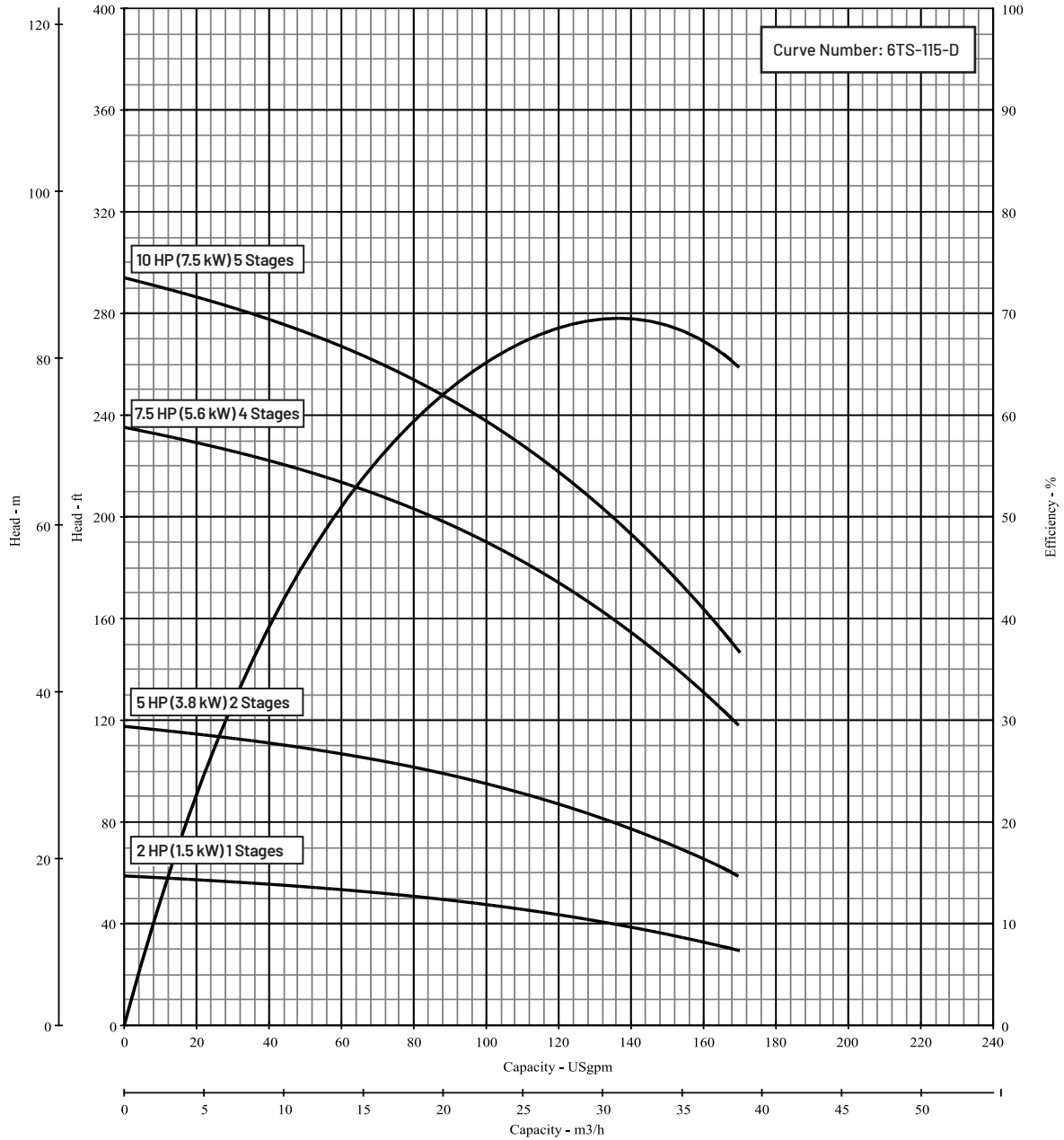

MODEL 6TS-115 SERIES

Series Name: 6TS-115

Pump Size: 6TS-115

Department of Energy Requirements		Available Configurations		Curve Conditions	
PE _{CL}	0.95	Submersible Turbine	6TS-115	Nominal RPM	3475
Model	6TS-115			Maximum Working Pressure	650 PSI (44.8 BAR)
Imp. Dia. (in.)	4.134			Based on Fresh Water @ F	68

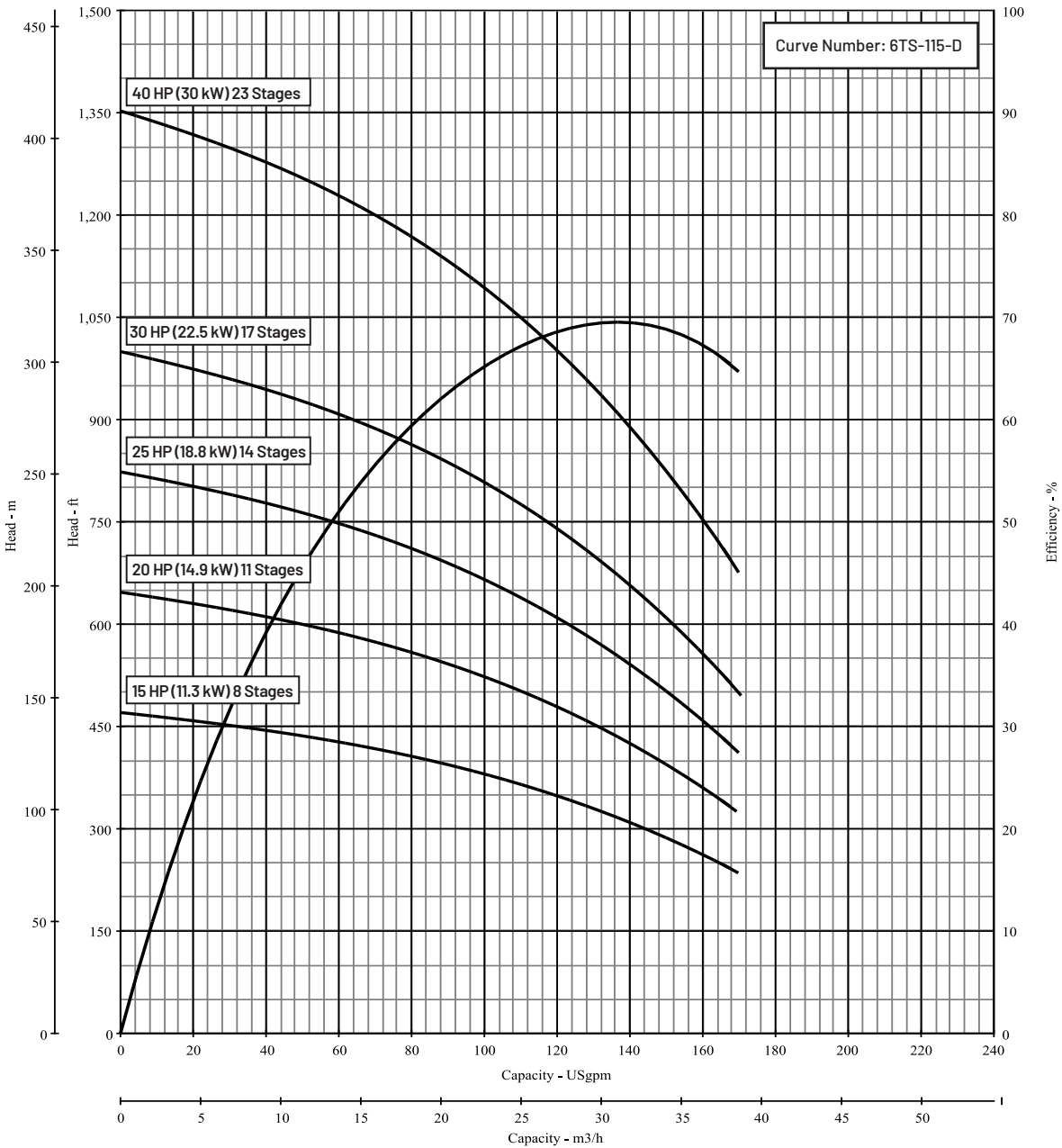

115 SERIES MIXED FLOW

Pump Kit Build Chart

60 Hz

60 Hz – 115 Series					
No. of Stages ▶	1	2	3	4	5
Horsepower ▶	2HP	5HP	7.5HP		10HP
Kilowatts ▶	1.5kW	3.7kW	5.6kW		7.5kW

Number of Kits Required – per No. of Stages

	1	2	3	4	5
A Kit 6TS-BKT4	1	1	1		1
B Kit 6TS-BKT6					
E Kit 6TS-115FST	1	1	1		1
L Kit 6TS-115MID	1*	1	2	3	4
U Kit 6TS-115-300S	1	1	1		1
Y Kit 6TS-D3NPT	1	1	1		1
Y1 Kit 6TS-D3BSP					

Pump Cut-Off Chart

60 Hz

U Kit 6TS-115-300 (short)					
No. of Stages ▶	1	2	3	4	5
Horsepower ▶	2HP	5HP	7.5HP		10HP
Kilowatts ▶	1.5kW	3.7kW	5.6kW		7.5kW

Length in Inches (millimeters)

	1	2	3	4	5
Shaft Cut-off	10.97 (278.5)	10.97 (278.5)	15.41 (391.5)	19.86 (504.5)	24.31 (617.5)
Straps Cut-off**	15.67 (398.1)	15.67 (398.1)	20.12 (511.1)	24.57 (624.1)	29.02 (737.1)
Straps Formed	14.76 (375)	14.76 (375)	19.21 (488)	23.66 (601)	28.11 (714)
Cable-Guard Cut-off	19.06 (484)	19.06 (484)	23.50 (597)	27.95 (710)	32.4 (823)

* Impeller not used in one-stage pumps.

** Length includes "J-bend".

Note: If using the 4 x 6 suction bracket, the shaft length must be increased by 0.67 inches (17 mm).

115 SERIES MIXED FLOW

Pump Kit Build Chart

60 Hz

60 Hz - 115 Series																		
No. of Stages ▶	6	7	8	9	10	11	12	13	14	15	16	17	18	19	20	21	22	23
Horsepower ▶	15HP			20HP			25HP			30HP			40HP					
Kilowatts ▶	11.2kW			14.9kW			18.6kW			22.4kW			29.8kW					

Number of Kits Required - per No. of Stages

B Kit 6TS-BKT6	1			1			1			1			1					
E Kit 6TS-115FST	1			1			1			1			1					
L Kit 6TS-115MID	5	6	7	8	9	10	11	12	13	14	15	16	17	18	19	20	21	22
U Kit 6TS-115-130S	1																	
V Kit 6TS-115-130M				1			1			1								
W Kit 6TS-115-130L													1					
Y Kit 6TS-D3NPT	1			1			1			1			1					
Y1 Kit 6TS-D3BSP	1			1			1			1			1					

Pump Cut-Off Chart

60 Hz

U Kit 6TS-115-300 (short), 1 - 8 stage V Kit 6TS-115-300 (medium), 9 - 17 stage													
No. of Stages ▶	6	7	8	9	10	11	12	13	14	15	16	17	
Horsepower ▶	15HP			20HP			25HP			30HP			
Kilowatts ▶	11.2kW			14.9kW			18.6kW			22.4kW			

Length in Inches (millimeters)

Shaft Cut-off	28.76 (730.5)	33.21 (843.5)	37.66 (956.5)	42.11 (1069.5)	46.56 (1182.5)	51.00 (1295.5)	55.45 (1408.5)	59.90 (1521.5)	64.35 (1634.5)	68.80 (1747.5)	73.25 (1860.5)	77.70 (1973.5)
Straps Cut-off**	33.47 (850.1)	37.92 (963.1)	42.37 (1076.1)	46.81 (1189.1)	51.26 (1302.1)	55.71 (1415.1)	60.16 (1528.1)	64.61 (1641.1)	69.06 (1754.1)	73.51 (1867.1)	77.96 (1980.1)	82.41 (2093.1)
Straps Formed	32.56 (827)	37.01 (940)	41.46 (1053)	45.91 (1166)	50.35 (1279)	54.80 (1392)	59.25 (1505)	63.70 (1618)	68.15 (1731)	72.60 (1844)	77.05 (1957)	81.50 (2070)
Cable-Guard Cut-off	36.85 (936)	41.30 (1049)	45.75 (1162)	50.20 (1275)	54.65 (1388)	59.09 (1501)	63.54 (1614)	67.99 (1727)	72.44 (1840)	76.89 (1953)	81.34 (2066)	85.79 (2179)

W Kit 6TS-115-300 (long)

No. of Stages ▶	18	19	20	21	22	23
Horsepower ▶	40HP					
Kilowatts ▶	29.8kW					

Length in Inches (millimeters)

Shaft Cut-off	82.15 (2086.5)	86.59 (2199.5)	91.04 (2312.5)	95.49 (2425.5)	99.94 (2538.5)	104.39 (2651.5)
Straps Cut-off**	86.85 (2206.1)	91.30 (2319.1)	95.75 (2432.1)	100.20 (2545.1)	104.65 (2658.1)	109.10 (2771.1)
Straps Formed	85.95 (2183)	90.39 (2296)	94.84 (2409)	99.29 (2522)	103.74 (2635)	108.19 (2748)
Cable-Guard Cut-off	90.24 (2292)	94.69 (2405)	99.13 (2518)	103.58 (2631)	108.03 (2744)	112.48 (2857)

**Length includes "J-bend".

Note: If using the 4 x 6 suction bracket, the shaft length must be increased by 0.67 inches (17 mm).

MODEL 6TS-155 SERIES

Series Name: 6TS-155

Pump Size: 6TS-155

Department of Energy Requirements		Available Configurations		Curve Conditions	
PEI _{CL}	0.96	Submersible Turbine	6TS-155	Nominal RPM	3475
Model	6TS-155			Maximum Working Pressure	650 PSI (44.8 BAR)
Imp. Dia. (in.)	4.134			Based on Fresh Water @ F	68

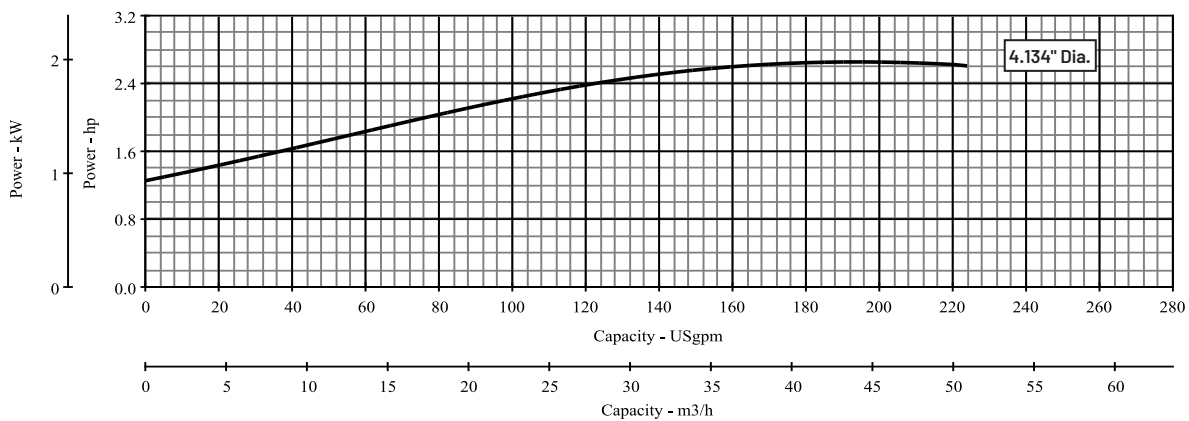
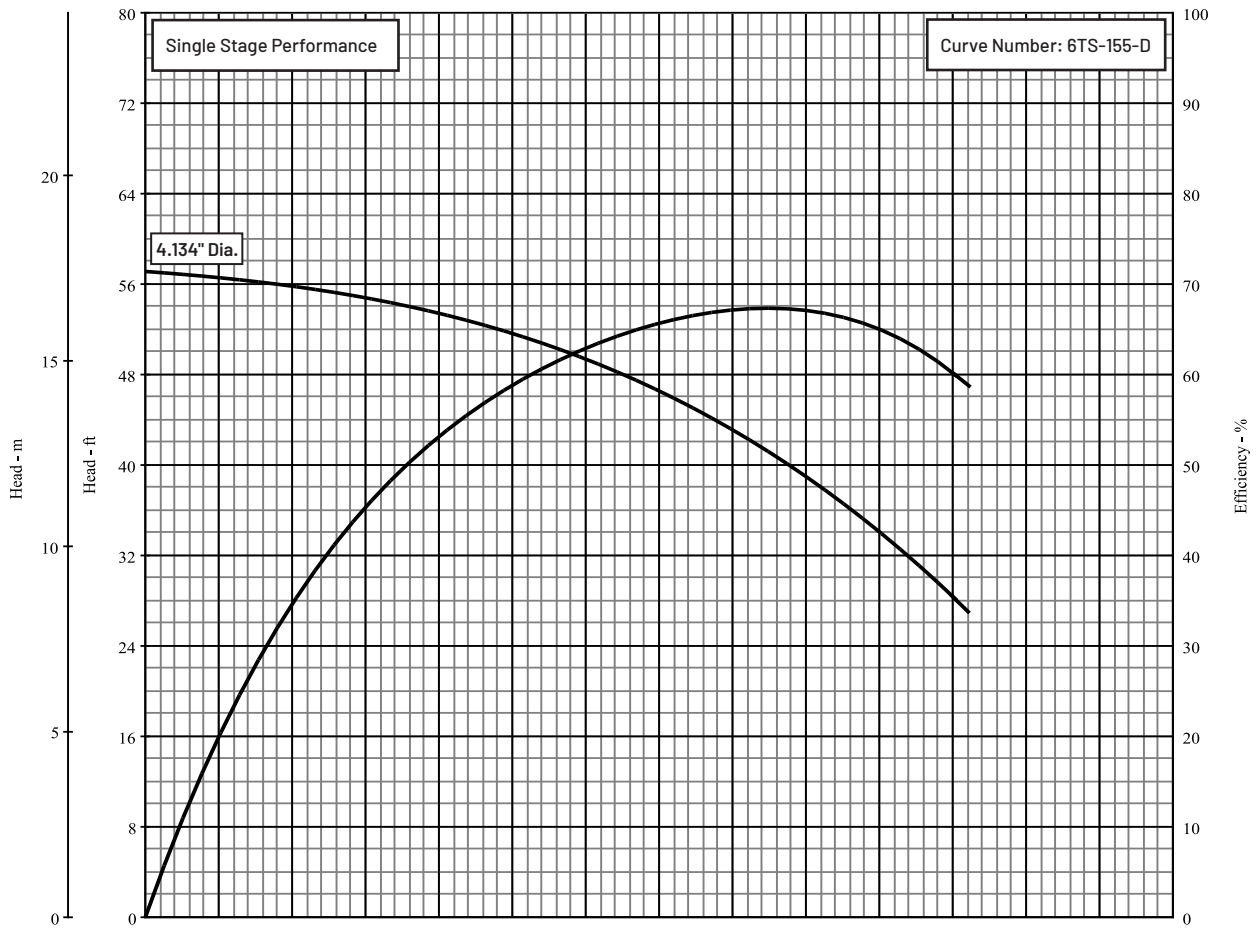

MODEL 6TS-155 SERIES

Series Name: 6TS-155

Pump Size: 6TS-155

Department of Energy Requirements		Available Configurations		Curve Conditions	
PE _{CL}	0.96	Submersible Turbine	6TS-155	Nominal RPM	3475
Model	6TS-155			Maximum Working Pressure	650 PSI (44.8 BAR)
Imp. Dia. (in.)	4.134			Based on Fresh Water @ F	68

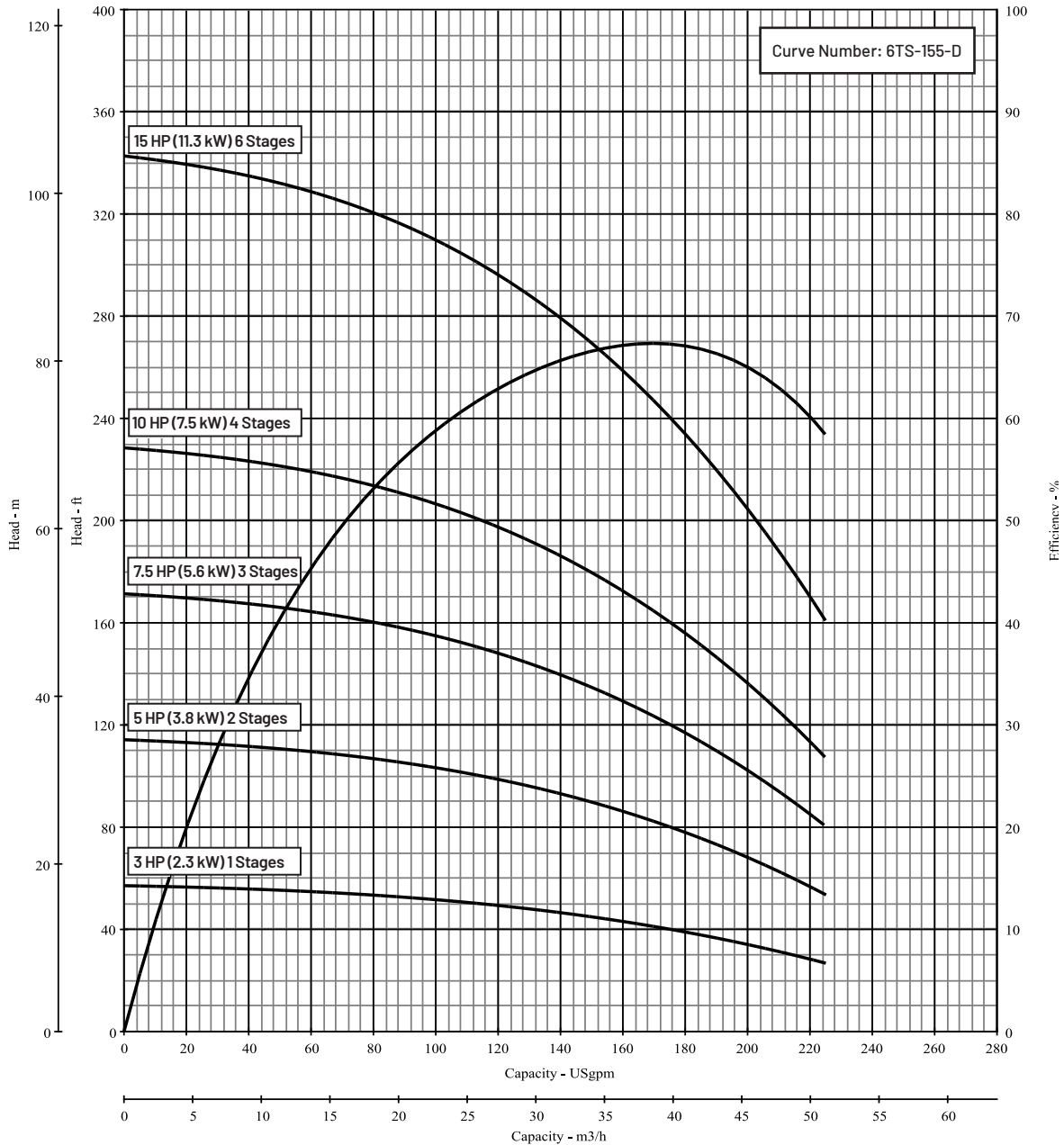

MODEL 6TS-155 SERIES

Series Name: 6TS-155

Pump Size: 6TS-155

Department of Energy Requirements		Available Configurations		Curve Conditions	
PEI _{CL}	0.96	Submersible Turbine	6TS-155	Nominal RPM	3475
Model	6TS-155			Maximum Working Pressure	650 PSI (44.8 BAR)
Imp. Dia. (in.)	4.134			Based on Fresh Water @ F	68

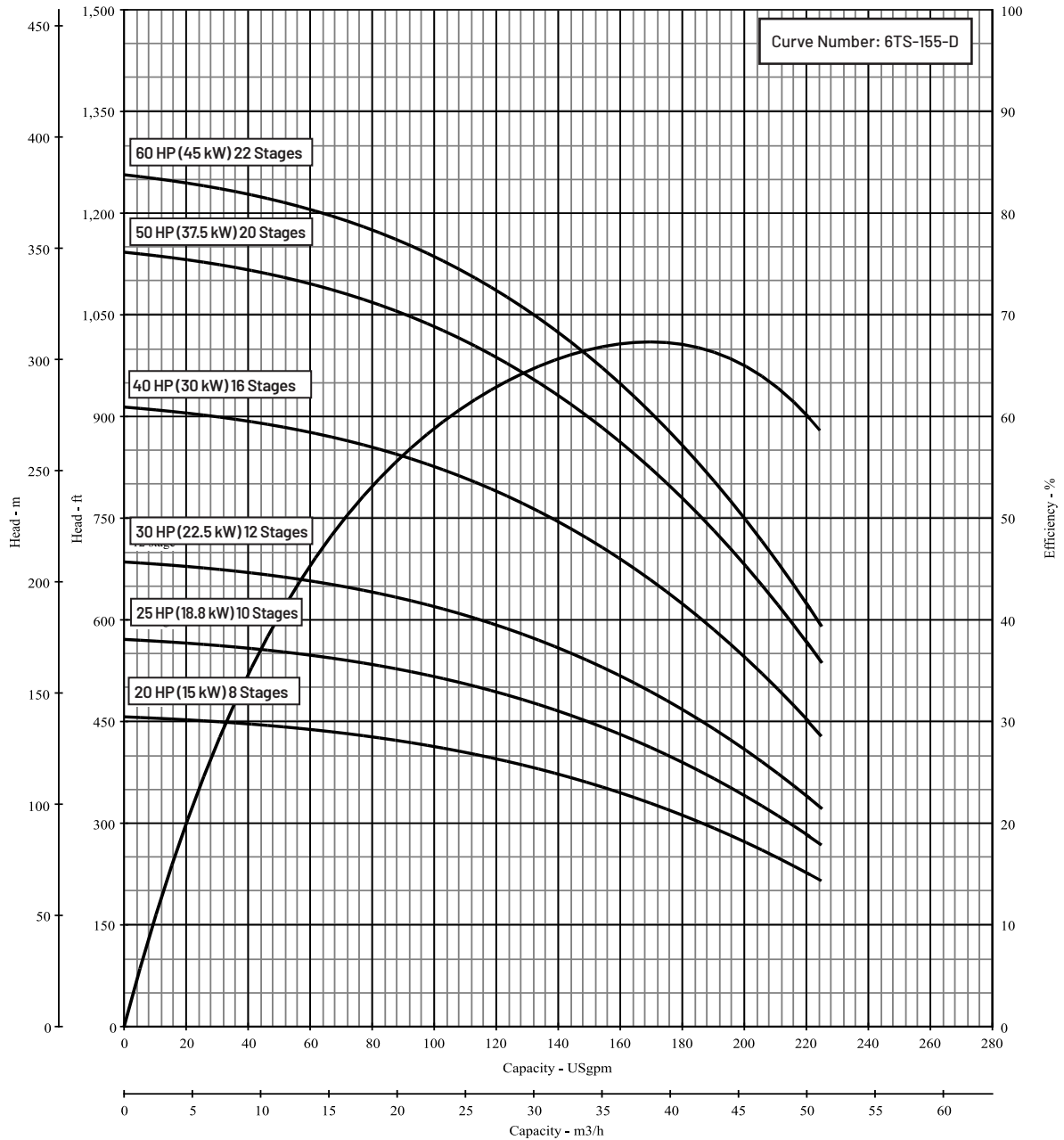

155 SERIES MIXED FLOW

Pump Kit Build Chart

60 Hz

60 Hz - 155 Series						
No. of Stages ▶	1	2	3	4	5	6
Horsepower ▶	3HP	5HP	7.5HP	10HP	15HP	
Kilowatts ▶	2.2kW	3.7kW	5.6kW	7.5kW	11.2kW	

Number of Kits Required – per No. of Stages

	1	2	3	4	5	6
A Kit 6TS-BKT4	1	1	1	1		
B Kit 6TS-BKT6					1	
F Kit 6TS-155FST	1	1	1	1	1	
M Kit 6TS-155MID	1	1	2	3	4	5
U Kit 6TS-115-300S	1	1	1	1	1	
Y Kit 6TS-D3NPT	1	1	1	1	1	
Y1 Kit 6TS-D3BSP						

Pump Cut-Off Chart

60 Hz

U Kit 6TS-115-300 (short)						
No. of Stages ▶	1	2	3	4	5	6
Horsepower ▶	3HP	5HP	7.5HP	10HP	15HP	
Kilowatts ▶	2.2kW	3.7kW	5.6kW	7.5kW	11.2kW	

Length in Inches (millimeters)

Shaft Cut-off	10.97 (278.5)	10.97 (278.5)	15.41 (391.5)	19.86 (504.5)	24.31 (617.5)	28.76 (730.5)
Straps Cut-off**	15.67 (398.1)	15.67 (398.1)	20.12 (511.1)	24.57 (624.1)	29.02 (737.1)	33.47 (850.1)
Straps Formed	14.76 (375)	14.76 (375)	19.21 (488)	23.66 (601)	28.11 (714)	32.56 (827)
Cable-Guard Cut-off	19.06 (484)	19.06 (484)	23.50 (597)	27.95 (710)	32.40 (823)	36.85 (936)

*Impeller not used in one-stage pumps.

**Length includes "J-bend".

Note: If using the 4 x 6 suction bracket, the shaft length must be increased by 0.67 inches (17 mm).

155 SERIES MIXED FLOW

Pump Kit Build Chart

60 Hz

60 Hz – 155 Series																
No. of Stages ▶	7	8	9	10	11	12	13	14	15	16	17	18	19	20	21	22
Horsepower ▶	20HP		25HP		30HP		40HP				50HP				60HP	
Kilowatts ▶	14.9kW		18.6kW		22.4kW		29.8kW				37.3kW				44.7kW	

Number of Kits Required – per No. of Stages

B Kit 6TS-BKT6	1	1	1	1	1	1	1	1	1	1	1	1	1	1	1	1
F Kit 6TS-155FST	1	1	1	1	1	1	1	1	1	1	1	1	1	1	1	1
L Kit 6TS-155MID	6	7	8	9	10	11	12	13	14	15	16	17	18	19	20	21
U Kit 6TS-115-130S	1															
V Kit 6TS-115-130M		1	1	1	1	1	1	1	1	1	1	1	1	1	1	1
W Kit 6TS-115-130L													1	1		
Y Kit 6TS-D3NPT	1	1	1	1	1	1	1	1	1	1	1	1	1	1	1	1
Y1 Kit 6TS-D3BSP	1	1	1	1	1	1	1	1	1	1	1	1	1	1	1	1

Pump Cut-Off Chart

60 Hz

U Kit 6TS-115-300 (short)												
No. of Stages ▶	7	8	9	10	11	12	13	14	15	16	17	
Horsepower ▶	20HP		25HP		30HP		40HP				50 P	
Kilowatts ▶	14.9kW		18.6kW		22.4kW		29.8kW				37.3 kW	

Length in Inches (millimeters)

Shaft Cut-off	33.21 (843.5)	37.66 (956.5)										
Straps Cut-off**	37.92 (963.1)	42.37 (1076.1)										
Straps Formed	37.01 (940)	41.46 (1053)										
Cable-Guard Cut-off	41.30 (1049)	45.75 (1162)										

V Kit 6TS-115-300 (medium)

Shaft Cut-off		42.11 (1069.5)	46.56 (1182.5)	51.00 (1295.5)	55.45 (1408.5)	59.90 (1521.5)	64.35 (1634.5)	68.80 (1747.5)	73.25 (1860.5)	77.70 (1973.5)
Straps Cut-off**		46.81 (1189.1)	51.26 (1302.1)	55.71 (1415.1)	60.16 (1528.1)	64.61 (1641.1)	69.06 (1754.1)	73.51 (1867.1)	77.96 (1980.1)	82.41 (2093.1)
Straps Formed		45.91 (1166)	50.35 (1279)	54.80 (1392)	59.25 (1505)	63.70 (1618)	68.15 (1731)	72.60 (1844)	77.05 (1957)	81.50 (2070)
Cable-Guard Cut-off		50.20 (1275)	54.65 (1388)	59.09 (1501)	63.54 (1614)	67.99 (1727)	72.44 (1840)	76.89 (1953)	81.34 (2066)	85.79 (2179)

W Kit 6TS-115-300 (long)

No. of Stages ▶	18	19	20	21	22
Horsepower ▶	50HP			60HP	
Kilowatts ▶	37.3kW			44.7kW	

Length in Inches (millimeters)

Shaft Cut-off	82.15 (2086.5)	86.59 (2199.5)	91.04 (2312.5)	95.49 (2425.5)	99.94 (2538.5)
Straps Cut-off**	86.85 (2206.1)	91.30 (2319.1)	95.75 (2432.1)	100.20 (2545.1)	104.65 (2658.1)
Straps Formed	85.95 (2183)	90.39 (2296)	94.84 (2409)	99.29 (2522)	103.74 (2635)
Cable-Guard Cut-off	90.24 (2292)	94.69 (2405)	99.13 (2518)	103.58 (2631)	108.03 (2744)

**Length includes "J-bend".

Note: If using the 4 x 6 suction bracket, the shaft length must be increased by 0.67 inches (17 mm).

MODEL 6TS-230 SERIES

Series Name: 6TS-230

Pump Size: 6TS-230

Department of Energy Requirements		Available Configurations		Curve Conditions	
PE _{lCL}	0.91	Submersible Turbine	6TS-230	Nominal RPM	3475
Model	6TS-230			Maximum Working Pressure	625 PSI (43 BAR)
Imp. Dia. (in.)	4.134			Based on Fresh Water @ F	68

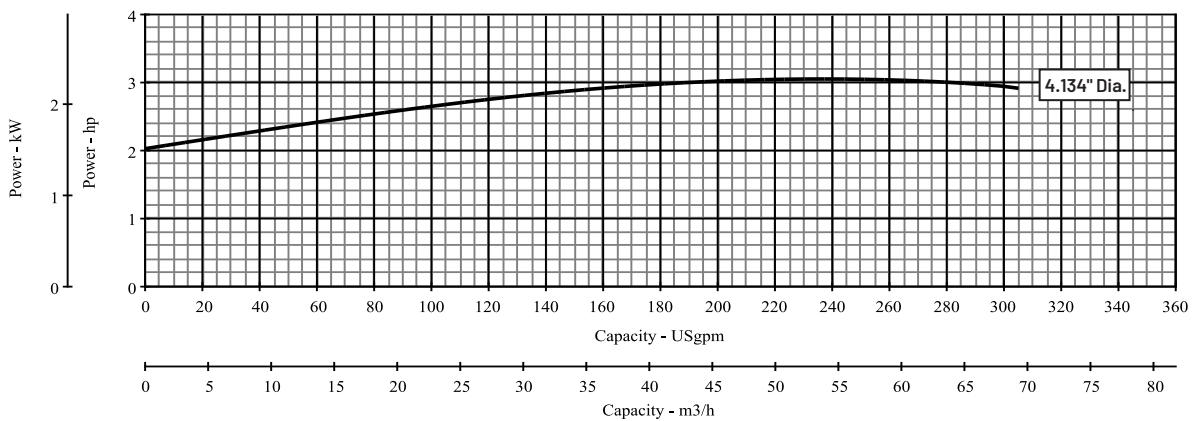
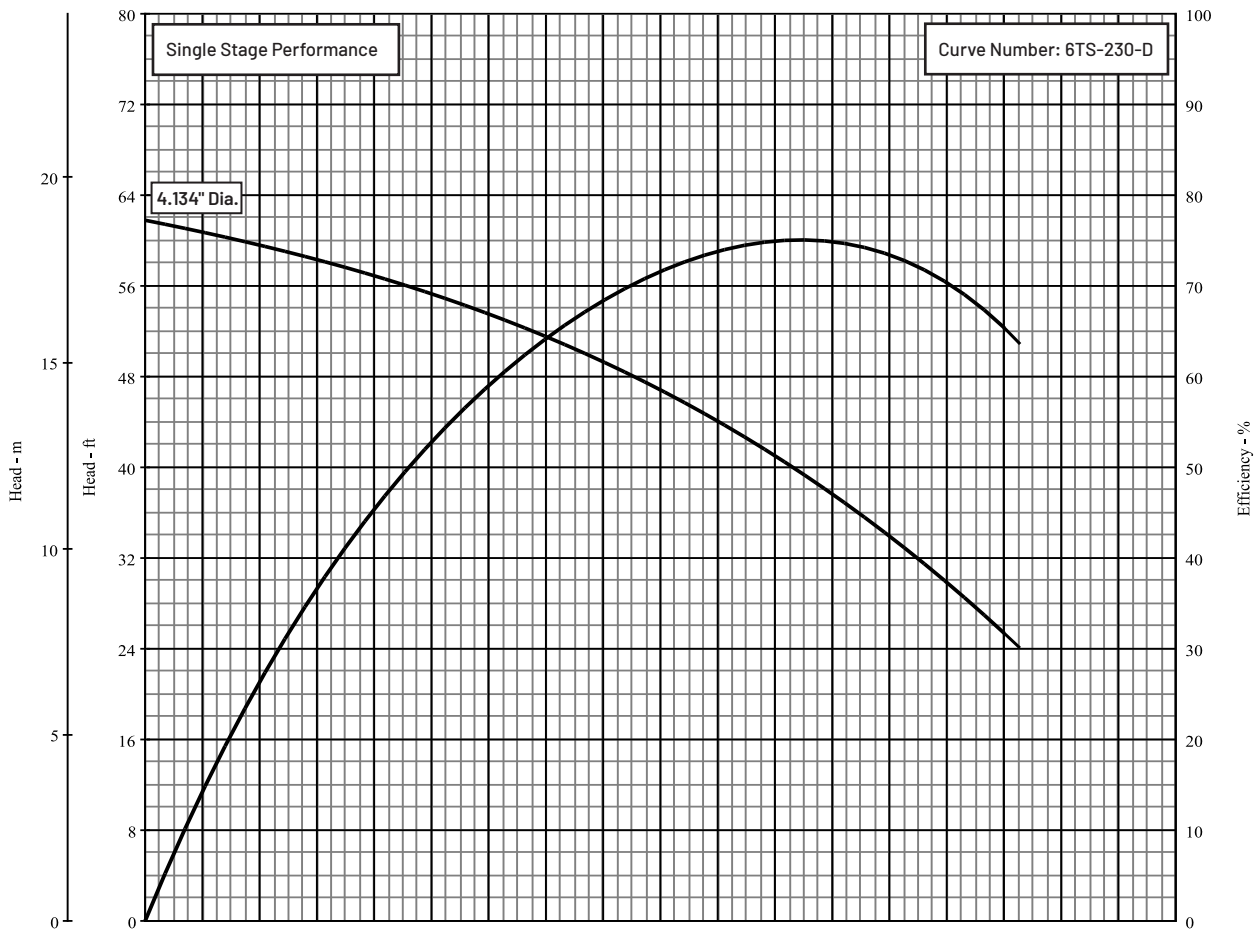

MODEL 6TS-230 SERIES

Series Name: 6TS-230

Pump Size: 6TS-230

Department of Energy Requirements		Available Configurations		Curve Conditions	
PE _{CLL}	0.91	Submersible Turbine	6TS-230	Nominal RPM	3475
Model	6TS-230			Maximum Working Pressure	625 PSI (43 BAR)
Imp. Dia. (in.)	4.134			Based on Fresh Water @ F	68

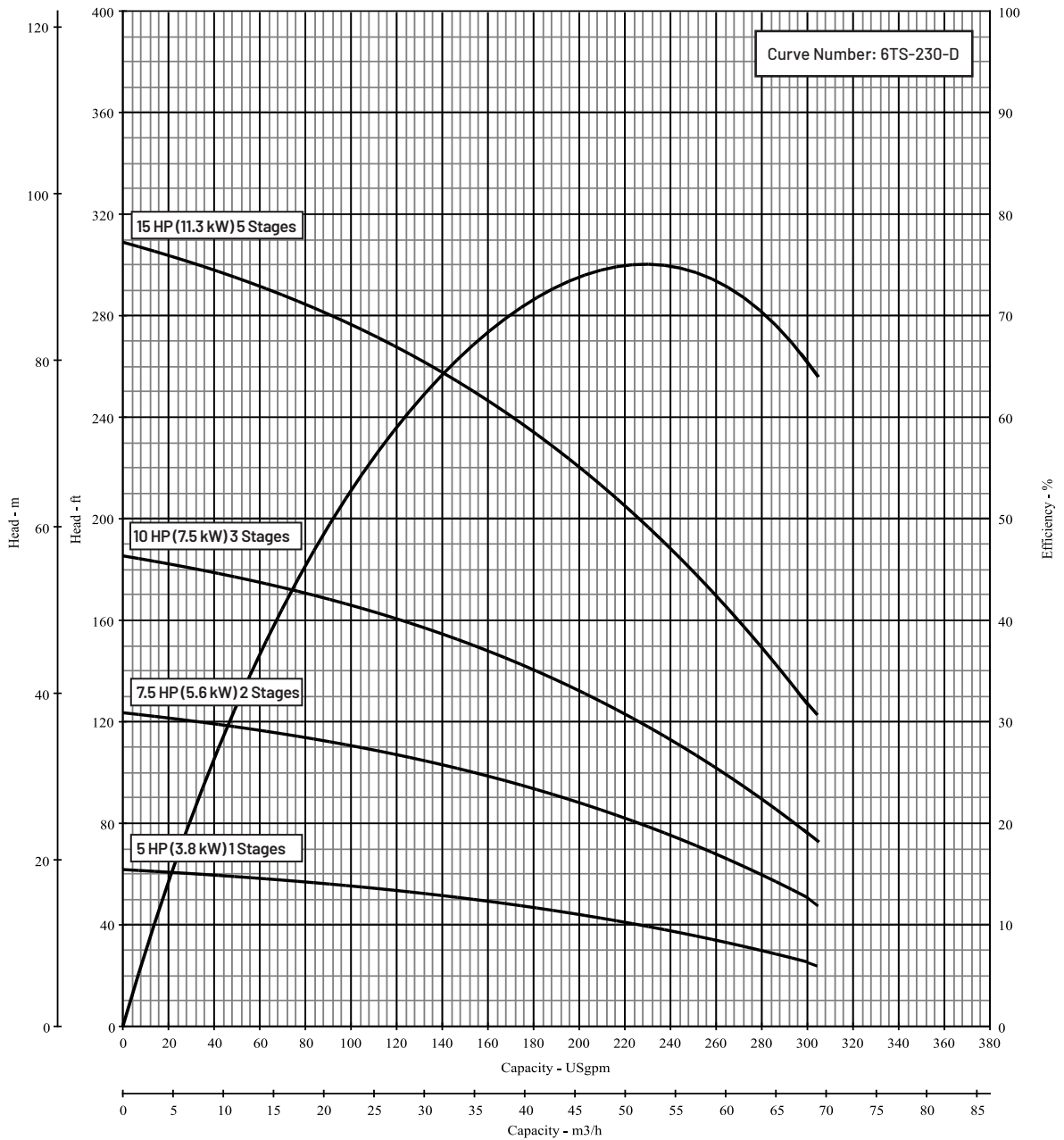

MODEL 6TS-230 SERIES

Series Name: 6TS-230

Pump Size: 6TS-230

Department of Energy Requirements		Available Configurations		Curve Conditions	
PEI _{CL}	0.91	Submersible Turbine	6TS-230	Nominal RPM	3475
Model	6TS-230			Maximum Working Pressure	625 PSI (43 BAR)
Imp. Dia. (in.)	4.134			Based on Fresh Water @ F	68

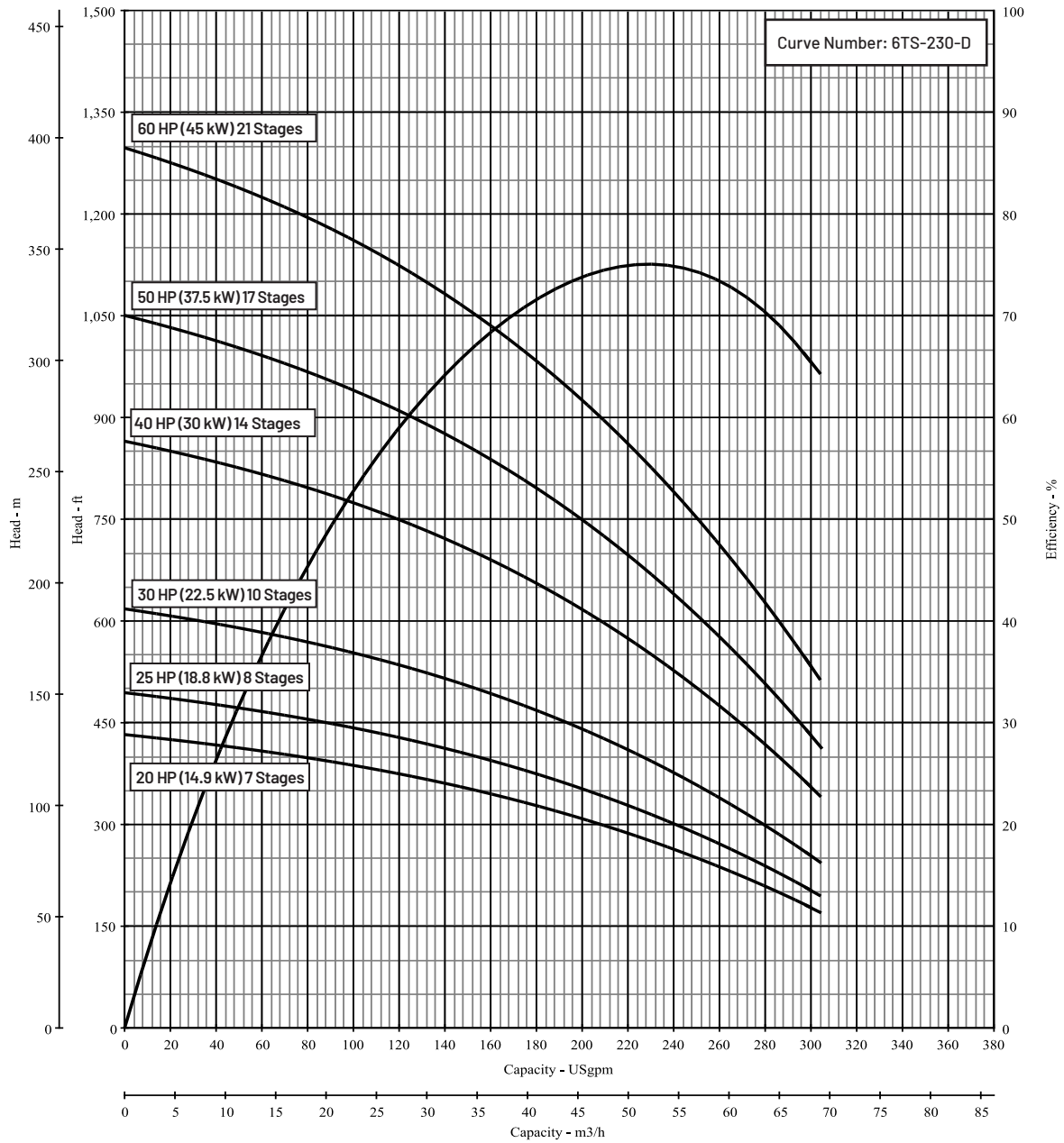

230 SERIES MIXED FLOW

Pump Kit Build Chart

60 Hz

60 Hz - 230 Series					
No. of Stages ▶	1	2	3	4	5
Horsepower ▶	5HP	7.5HP	10HP	15HP	
Kilowatts ▶	3.7kW	5.6kW	7.5kW	11.2kW	

Number of Kits Required – per No. of Stages

	1	2	3	4	5
A Kit 6TS-BKT4	1	1	1		
B Kit 6TS-BKT6				1	
G Kit 6TS-230FST	1	1	1	1	
N Kit 6TS-230MID	1*	1	2	3	4
U Kit 6TS-115-300S	1	1	1	1	
Z Kit 6TS-D4NPT	1	1	1		
Z1 Kit 6TS-D4BSP				1	

Pump Cut-Off Chart

60 Hz

U Kit 6TS-230-300 (short)					
No. of Stages ▶	1	2	3	4	5
Horsepower ▶	5HP	7.5HP	10HP	15HP	
Kilowatts ▶	3.7kW	5.6kW	7.5kW	11.2kW	

Length in Inches (millimeters)

Shaft Cut-off	10.97 (278.5)	10.97 (278.5)	15.41 (391.5)	19.86 (504.5)	24.31 (617.5)
Straps Cut-off**	15.67 (398.1)	15.67 (398.1)	20.12 (511.1)	24.57 (624.1)	29.02 (737.1)
Straps Formed	14.76 (375)	14.76 (375)	19.21 (488)	23.66 (601)	28.11 (714)
Cable-Guard Cut-off	19.06 (484)	19.06 (484)	23.50 (597)	27.95 (710)	32.40 (823)

* Impeller not used in one-stage pumps.

** Length includes "J-bend".

Note: If using the 4 x 6 suction bracket, the shaft length must be increased by 0.67 inches (17 mm).

230 SERIES MIXED FLOW

Pump Kit Build Chart

60 Hz

60 Hz - 230 Series																
No. of Stages ▶	6	7	8	9	10	11	12	13	14	15	16	17	18	19	20	21
Horsepower ▶	20HP		25HP	30HP		40HP				50HP			60HP			
Kilowatts ▶	14.9kW		18.6kW	22.4kW		29.8kW				37.3kW			44.7kW			

Number of Kits Required - per No. of Stages

B Kit 6TS-BKT6	1	1	1	1	1	1	1	1	1	1	1	1	1	1	1	1
G Kit 6TS-230FST	1	1	1	1	1	1	1	1	1	1	1	1	1	1	1	1
N Kit 6TS-230MID	5	6	7	8	9	10	11	12	13	14	15	16	17	18	19	20
U Kit 6TS-115-300S	1	1														
V 6TS-115-300M			1	1	1	1	1	1	1	1	1	1	1	1	1	1
W Kit 6TS-115-300L															1	
Z Kit 6TS-D4NPT	1	1	1	1	1	1	1	1	1	1	1	1	1	1	1	1
Z1 Kit 6TS-D4BSP	1	1	1	1	1	1	1	1	1	1	1	1	1	1	1	1

Pump Cut-Off Chart

60 Hz

U Kit 6TS-115-300 (short)														
No. of Stages ▶	6	7	8	9	10	11	12	13	14	15	16	17		
Horsepower ▶	20HP		25HP	30HP		40HP				50HP				
Kilowatts ▶	14.9kW		18.6kW	22.4kW		29.8kW				37.3kW				

Length in Inches (millimeters)

Shaft Cut-off	28.76 (730.5)	33.21 (843.5)	37.66 (956.5)													
Straps Cut-off**	33.47 (850.1)	37.92 (963.1)	42.37 (1076.1)													
Straps Formed	32.56 (827)	37.01 (940)	41.46 (1053)													
Cable-Guard Cut-off	36.85 (936)	41.30 (1049)	45.75 (1162)													

V Kit 6TS-115-300 (medium)

Shaft Cut-off				42.11 (1069.5)	46.56 (1182.5)	51.00 (1295.5)	55.45 (1408.5)	59.90 (1521.5)	64.35 (1634.5)	68.80 (1747.5)	73.25 (1860.5)	77.70 (1973.5)
Straps Cut-off**				46.81 (1189.1)	51.26 (1302.1)	55.71 (1415.1)	60.16 (1528.1)	64.61 (1641.1)	69.06 (1754.1)	73.51 (1867.1)	77.96 (1980.1)	82.41 (2093.1)
Straps Formed				45.91 (1166)	50.35 (1279)	54.80 (1392)	59.25 (1505)	63.70 (1618)	68.15 (1731)	72.60 (1844)	77.05 (1957)	81.50 (2070)
Cable-Guard Cut-off				50.20 (1275)	54.65 (1388)	59.09 (1501)	63.54 (1614)	67.99 (1727)	72.44 (1840)	76.89 (1953)	81.34 (2066)	85.79 (2179)

W Kit 6TS-115-300 (long)

No. of Stages ▶	18	19	20	21
Horsepower ▶	60HP			
Kilowatts ▶	44.7kW			

Length in Inches (millimeters)

Shaft Cut-off	82.15 (2086.5)	86.59 (2199.5)	91.04 (2312.5)	95.49 (2425.5)
Straps Cut-off**	86.85 (2206.1)	91.30 (2319.1)	95.75 (2432.1)	100.20 (2545.1)
Straps Formed	85.95 (2183)	90.39 (2296)	94.84 (2409)	99.29 (2522)
Cable-Guard Cut-off	90.24 (2292)	94.69 (2405)	99.13 (2518)	103.58 (2631)

**Length includes "J-bend".

Note: If using the 4 x 6 suction bracket, the shaft length must be increased by 0.67 inches (17 mm).

MODEL 6TS-300 SERIES

Series Name: 6TS-300

Pump Size: 6TS-300

Department of Energy Requirements		Available Configurations		Curve Conditions	
PEI _{CL}	0.94	Submersible Turbine	6TS-300	Nominal RPM	3475
Model	6TS-300			Maximum Working Pressure	625 PSI (43 BAR)
Imp. Dia. (in.)	4.134			Based on Fresh Water @ F	68

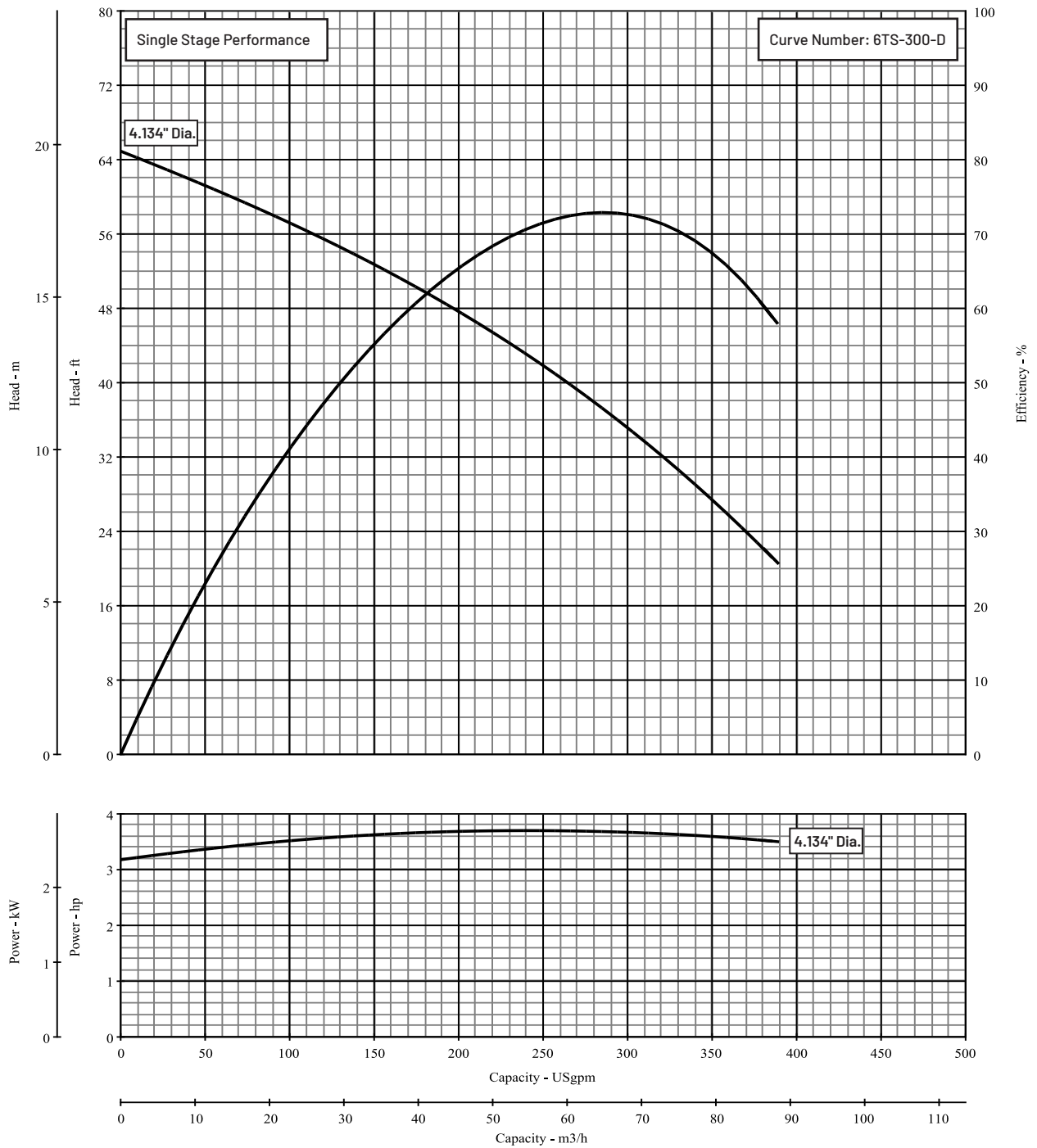

MODEL 6TS-300 SERIES

Series Name: **6TS-300**

Pump Size: **6TS-300**

Department of Energy Requirements		Available Configurations		Curve Conditions	
PE _{CL}	0.94	Submersible Turbine	6TS-300	Nominal RPM	3475
Model	6TS-300			Maximum Working Pressure	625 PSI (43 BAR)
Imp. Dia. (in.)	4.134			Based on Fresh Water @ F	68

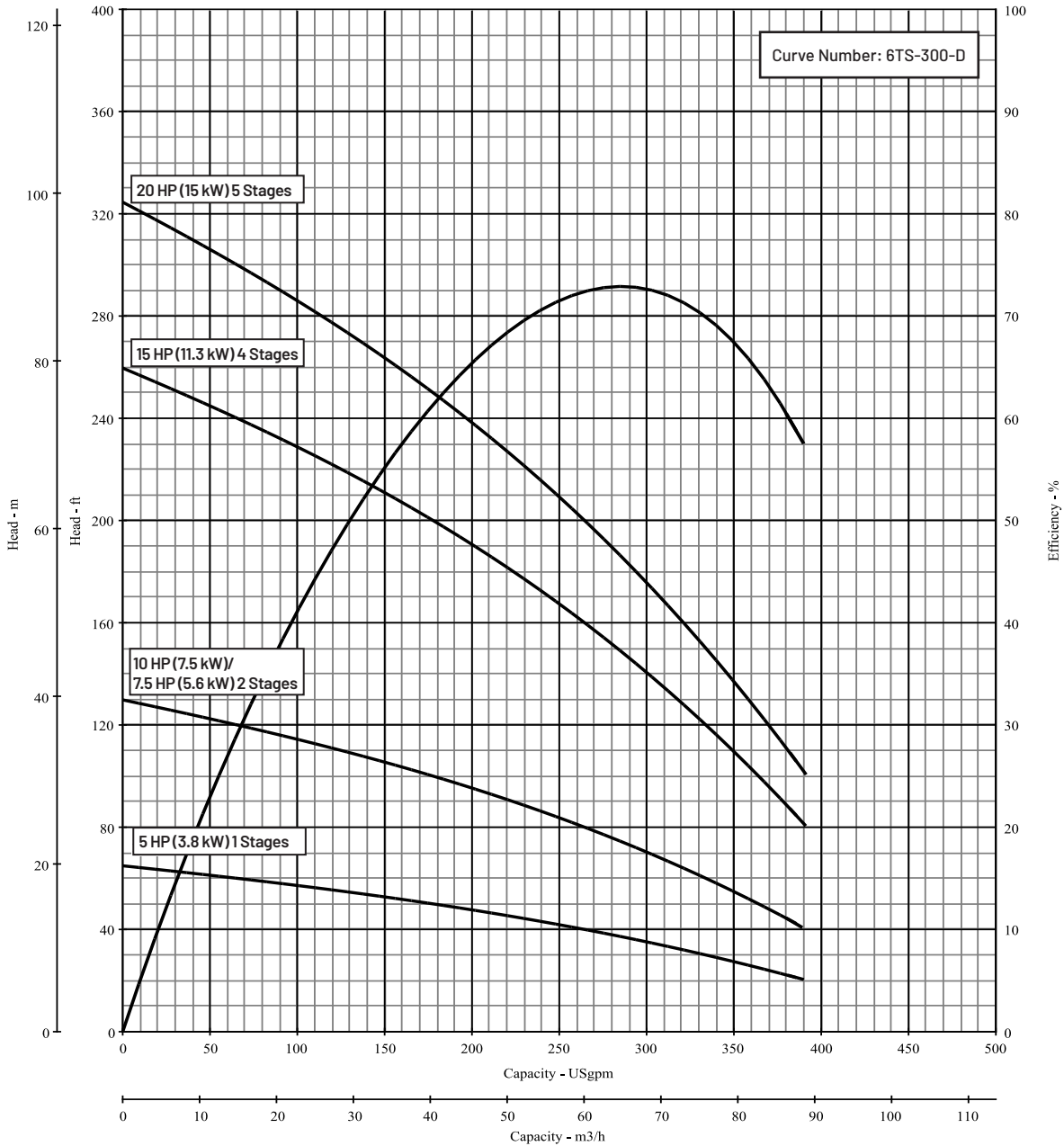

MODEL 6TS-300 SERIES

Series Name: **6TS-300**

Pump Size: **6TS-300**

Department of Energy Requirements		Available Configurations		Curve Conditions	
PEI _{CL}	0.94	Submersible Turbine	6TS-300	Nominal RPM	3475
Model	6TS-300			Maximum Working Pressure	625 PSI (43 BAR)
Imp. Dia. (in.)	4.134			Based on Fresh Water @ F	68

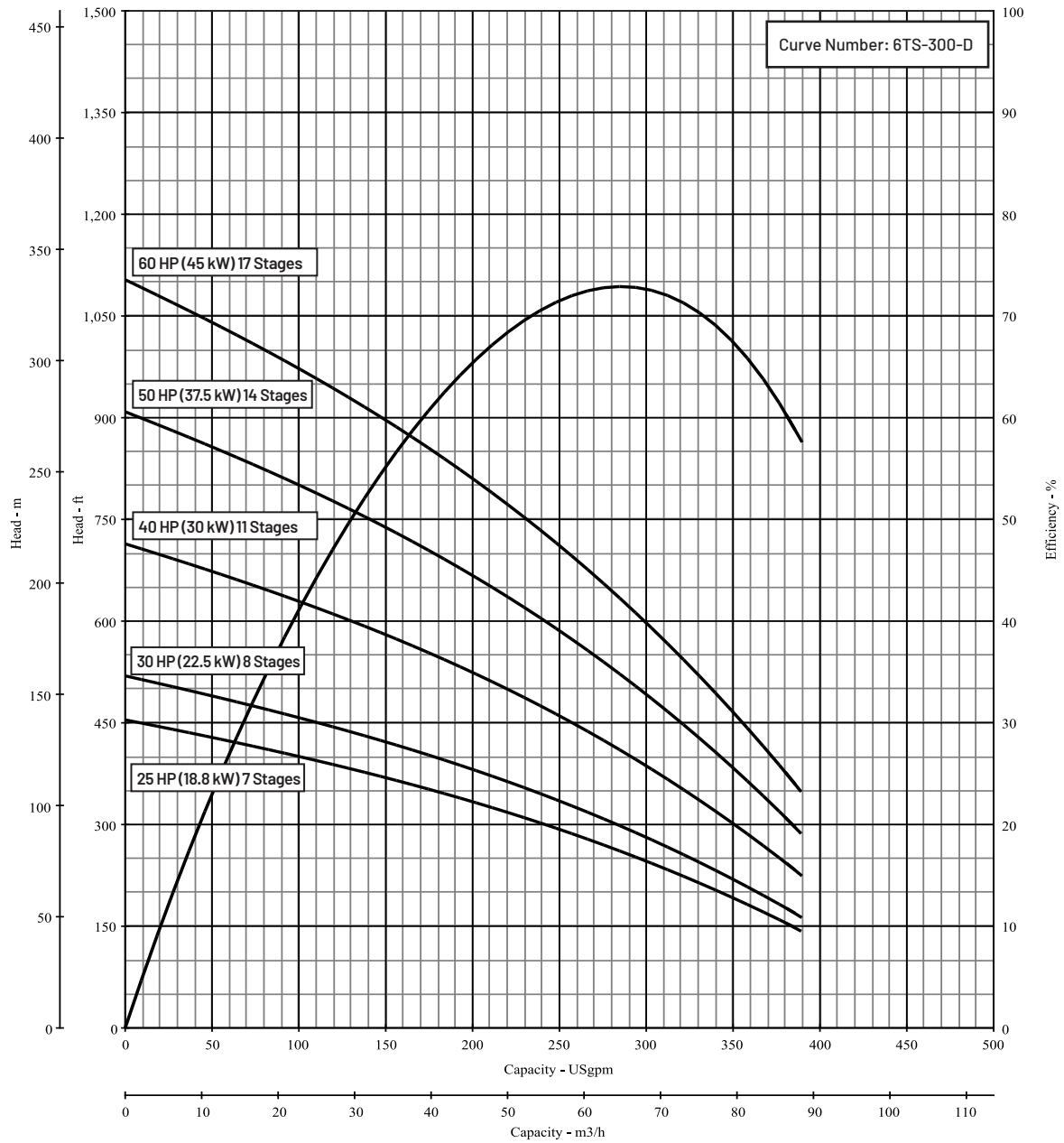

300 SERIES MIXED FLOW

Pump Kit Build Chart

60 Hz

60 Hz – 300 Series					
No. of Stages ▶	1	2	3	4	5
Horsepower ▶	5HP	10HP	15HP		20HP
Kilowatts ▶	3.7kW	7.5kW	11.2kW		14.9kW

Number of Kits Required – per No. of Stages

	1	2	3	4	5
A Kit 6TS-BKT4	1	1			
B Kit 6TS-BKT6			1	1	
H Kit 6TS-300FST	1	1	1	1	1
P Kit 6TS-300MID	1	1	2	3	4
U Kit 6TS-115-300S	1	1	1	1	1
Z Kit 6TS-D4NPT	1	1	1		1
Z1 Kit 6TS-D4BSP					

Pump Cut-Off Chart

60 Hz

U Kit 6TS-115-300 (short)					
No. of Stages ▶	1	2	3	4	5
Horsepower ▶	5HP	10HP	15HP		20HP
Kilowatts ▶	3.7kW	7.5kW	11.2kW		14.9kW

Length in Inches (millimeters)

	1	2	3	4	5
Shaft Cut-off	10.97 (278.5)	10.97 (278.5)	15.41 (391.5)	19.86 (504.5)	24.31 (617.5)
Straps Cut-off**	15.67 (398.1)	15.67 (398.1)	20.12 (511.1)	24.57 (624.1)	29.02 (737.1)
Straps Formed	14.76 (375)	14.76 (375)	19.21 (488)	23.66 (601)	28.11 (714)
Cable-Guard Cut-off	19.06 (484)	19.06 (484)	23.50 (597)	27.95 (710)	32.40 (823)

*Impeller not used in one-stage pumps.

**Length includes "J-bend".

Note: If using the 4 x 6 suction bracket, the shaft length must be increased by 0.67 inches (17 mm).

300 SERIES MIXED FLOW

Pump Kit Build Chart

60 Hz

60 Hz - 300 Series												
No. of Stages ▶	6	7	8	9	10	11	12	13	14	15	16	17
Horsepower ▶	25HP		30HP	40HP			50HP			60HP		
Kilowatts ▶	14.9kW		18.6kW	29.8kW			37.3kW			44.7kW		

Number of Kits Required – per No. of Stages

B Kit 6TS-BKT6	1	1	1			1			1			
H Kit 6TS-300FST	1	1	1			1			1			
P Kit 6TS-300MID	5	6	7	8	9	10	11	12	13	14	15	16
U Kit 6TS-115-300S	1		1									
V Kit 6TS-115-300M				1			1			1		
Z Kit 6TS-D4NPT	1		1	1			1			1		
ZI Kit 6TS-D4BSP				1			1			1		

Pump Cut-Off Chart

60 Hz

U Kit 6TS-115-300 (short)												
No. of Stages ▶	6	7	8	9	10	11	12	13	14	15	16	17
Horsepower ▶	25HP		30HP	40HP			50HP			60HP		
Kilowatts ▶	18.6kW		22.4kW	29.8kW			37.3kW			44.7kW		

Length in Inches (millimeters)

Shaft Cut-off	28.76 (730.5)	33.21 (843.5)	37.66 (956.5)									
Straps Cut-off**	33.47 (850.1)	37.92 (963.1)	42.37 (1076.1)									
Straps Formed	32.56 (827)	37.01 (940)	41.46 (1053)									
Cable-Guard Cut-off	36.85 (936)	41.30 (1049)	45.75 (1162)									
V Kit 6TS-115-300 (medium)												
Shaft Cut-off				42.11 (1069.5)	46.56 (1182.5)	51.00 (1295.5)	55.45 (1408.5)	59.90 (1521.5)	64.35 (1634.5)	68.80 (1747.5)	73.25 (1860.5)	77.70 (1973.5)
Straps Cut-off**				46.81 (1189.1)	51.26 (1302.1)	55.71 (1415.1)	60.16 (1528.1)	64.61 (1641.1)	69.06 (1754.1)	73.51 (1867.1)	77.96 (1980.1)	82.41 (2093.1)
Straps Formed				45.91 (1166)	50.35 (1279)	54.80 (1392)	59.25 (1505)	63.70 (1618)	68.15 (1731)	72.60 (1844)	77.05 (1957)	81.50 (2070)
Cable-Guard Cut-off				50.20 (1275)	54.65 (1388)	59.09 (1501)	63.54 (1614)	67.99 (1727)	72.44 (1840)	76.89 (1953)	81.34 (2066)	85.79 (2179)

**Length includes "J-bend".

Note: If using the 4 x 6 suction bracket, the shaft length must be increased by 0.67 inches (17 mm).

ASSEMBLY

Assembly Instructions Step-by-Step – Mixed Flow

Prior to assembly, refer to shaft cut-off and straightening instructions on page 38.

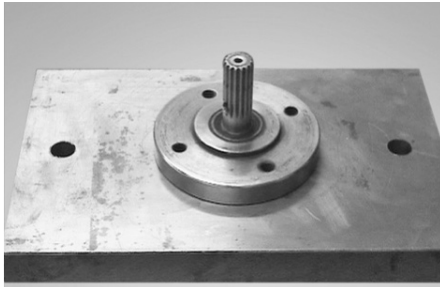

► STEP 1

Pump Assembly Fixture #1A. Standard 6" NEMA Motor fit.



► STEP 2

Assemble Suction Bracket #25 to Assembly Fixture #1A using Hex Bolts #30 and Split Washers #31 (Suction Bracket Kit).

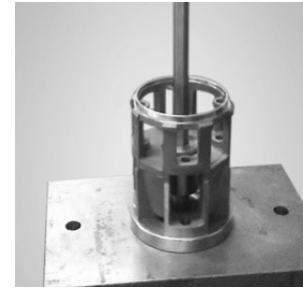

► STEP 3

Ref: See page 53 for Shaft/Coupling Assembly. Clean Pump Shaft/Coupling Assembly #27, 28, and 29 (Shaft/Strap/Cable Guard Kit and Suction Bracket Kit). Insert on to Fixture #1A.



► STEP 4

Slide the Inlet Shaft Spacer #19 (longest spacer in the First-Stage Kit) on to the Pump Shaft so that it rests on the top of the Coupling #28).

NOTE: If using 4" motor bracket (BKT4), install 17.04mm spacer (M14054) #19a, then the Inlet Shaft Spacer #19.



► STEP 5

Fit the First-Stage Adapter #20 (First-Stage Kit) in Suction Bracket #25.



► STEP 6

Slide First-Stage Impeller #8 (First-Stage Kit) on the Shaft until seated on the Inlet Shaft Spacer #19.



► STEP 7

Assemble the Thrust Shaft Spacer #15 (the next shortest spacer – First-Stage Kit) on the shaft until it rests on the Impeller #8.



► STEP 8

Assemble the Thrust Washer #14 (smallest ID center hole – First-Stage Kit) on the Thrust Shaft Spacer #15.



► STEP 9

Assemble the Distance Sleeve #11 (second longest spacer), Fiber Washer #13 and Stainless Washer #12 (largest ID center hole – First-Stage Kit) in that order, until they rest on the Thrust Support Washer #14.

ASSEMBLY

Assembly Instructions Step-by-Step – Mixed Flow



► STEP 10

Place the Bowl w/Diffuser #9 (Intermediate-Stage Kit) over the First Stage Impeller #8.



► STEP 11

Gently tap the Bowl w/Diffuser #9 with the help of a rubber mallet.



► STEP 12

Slide an Impeller #8 (Intermediate-Stage Kit) over the shaft until it rests on the Distance Sleeve #11.

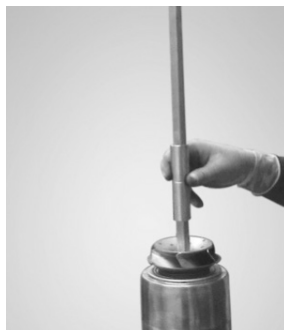

► STEP 13

Slide a Stage Spacer #10 (longest of all spacers – Intermediate-Stage Kit) to rest on the Impeller #8.



► STEP 14

Repeat steps 11, 12 and 13 (determined by pump stage count).
Rotate shaft for “free rotation” after every stage of assembly.



► STEP 15

Final Top-Stage use Discharge Shaft Spacer #7 (tiny spacer – First-Stage Kit) in place of extra Stage Spacer #10 from last Intermediate-Stage Kit.
Assemble the last Impeller #8 on to the shaft so that it rests on the Stage Spacer #10. Slide the Discharge Shaft Spacer #7 (First-Stage Kit) on to the top Impeller #8.



► STEP 16

Place the hard-chrome plated Bearing Journal #6 (comes in baggy with shaft compression set screw and washer – Suction Bracket Kit) until it rests on the top of the Discharge Shaft Spacer #7.



► STEP 17

Fit Stack Compression Washer #5 (Suction Bracket Kit) over the Bearing Journal #6. Apply Loctite™ threadlocker® to the Stack Compression Capscrew #4. (Suction Bracket Kit).



► STEP 18

Tighten Stack Compression Screw #4. Do not exceed 15 ft.-lbs. (2.0 kgm).

ASSEMBLY

Assembly Instructions Step-by-Step – Mixed Flow



► STEP 19

Assemble the Top Bowl #3 (First-Stage Kit) over the shaft and seat it on the top Bowl w/Diffuser #9.



► STEP 20

Place the Check Valve Poppet #2 (Discharge Kit) on the Top Bowl #3 (if required).



► STEP 21

Vertically align the Discharge #1 (Discharge Kit) "strap slots" with the Suction Bracket #25 "strap slots".

Fit the Discharge #1 on to the Top Bowl #3 and tap it with a rubber mallet to fit properly.

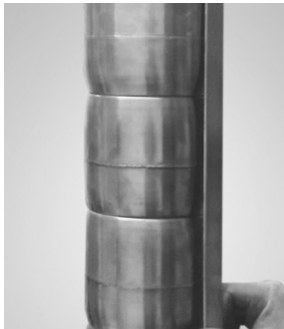

► STEP 23

Ref: See page 54 for Strap bending. Fit Straps #21 (Shaft/Straps/Cable Guard Kit) in to the "strap slots" in the Discharge #1.

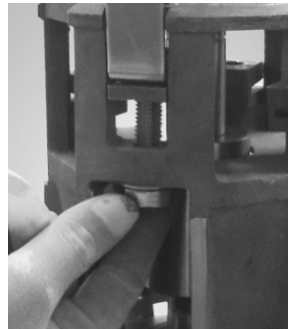

► STEP 23

Assemble Lock Washer #17 on the Strap Capscrew #18 (Suction Bracket Kit) through Suction Bracket #25 and pump Strap #21 and hand tighten to Strap Nut #16 as far as possible.

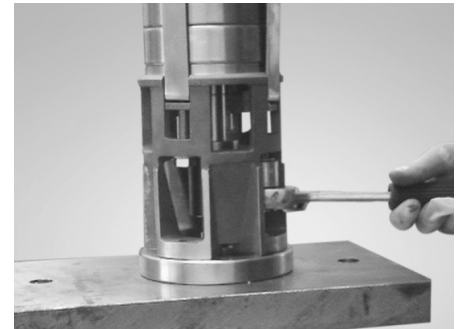

► STEP 24

Tighten the pump Strap Capscrews #18 diagonally, using a spanner or ratchet wrench.



► STEP 25 (FOR REFERENCE ONLY)

Using a torque wrench, tighten Strap Capscrews #18 to 47 ft.-lbs. (6.5 kgm).

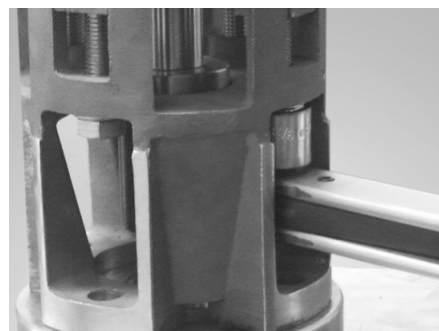

► STEP 26

Torque Strap Capscrews #18 diagonally in 10 ft.-lbs. (1.5 kilogram) "steps" until 47 ft.-lbs. (6.5 kilogram) torque value is achieved.



► STEP 27

Assembled pump ready for Coupling Guard #26. Suction Screen #24 and Cable-Guard #23 assembly.

ASSEMBLY

Assembly Instructions Step-by-Step – Mixed Flow

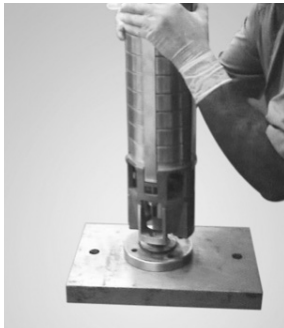

▶ STEP 28

The assembled pump is taken off the Pump Assembly Fixture #1A.



▶ STEP 29

Check for free rotation of the pump shaft assembly with the help of Rotation Checking Fixture #2A.

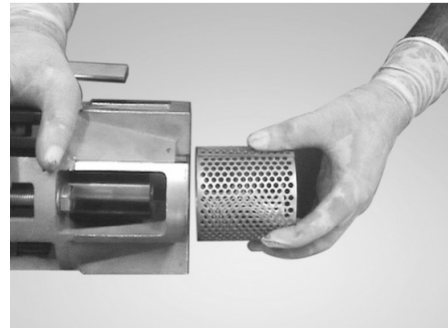

▶ STEP 30

Insert the Coupling Screen #26 (Suction Bracket Kit) inside the Suction Bracket #25 bore so that it completely covers the Coupling #28.
6" NEMA Suction Bracket only.



▶ STEP 31

Assemble Suction Screen #24 using Suction Screen Screws #32 (Suction Bracket Kit) to Suction Bracket #25.

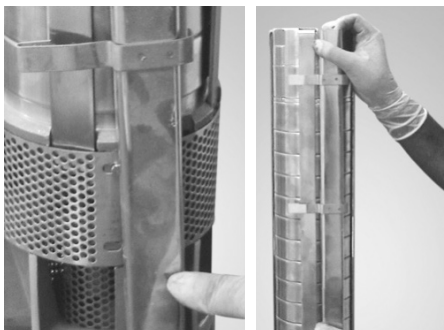

▶ STEP 32

Align Cable Guard #23 (Shaft/Strap/Cable Guard Kit) with "motor cable-slot" on Suction Bracket #25. Attach Cable Guard #23 to adjacent pump Straps #21 using Cable Guard Brackets #22 (Suction Bracket Kit).
Cable Guard #23 cut to length and de-burred per cut-off charts.

▶ STEP 33

Apply Model Plate (LK-BK) – fill in appropriate fields using an electronic pen or die stamp.

▶ STEP 34

Assemble to Pentair Pentek* or Hitachi® motor.

ASSEMBLY

Pump Assembly - Mixed Flow

MODEL 6TS-115 Series
4" Motor Bracket

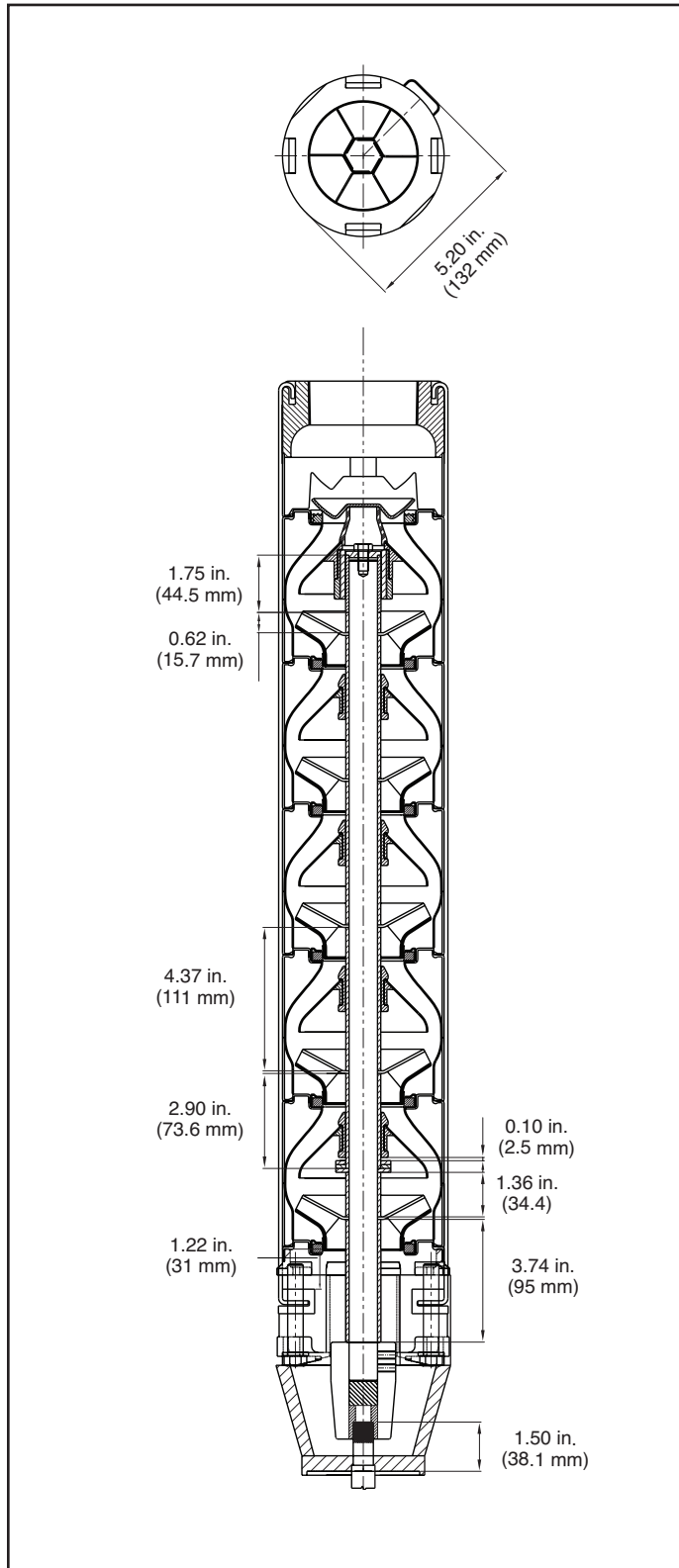

MODEL 6TS-115 Series
6" Motor Bracket

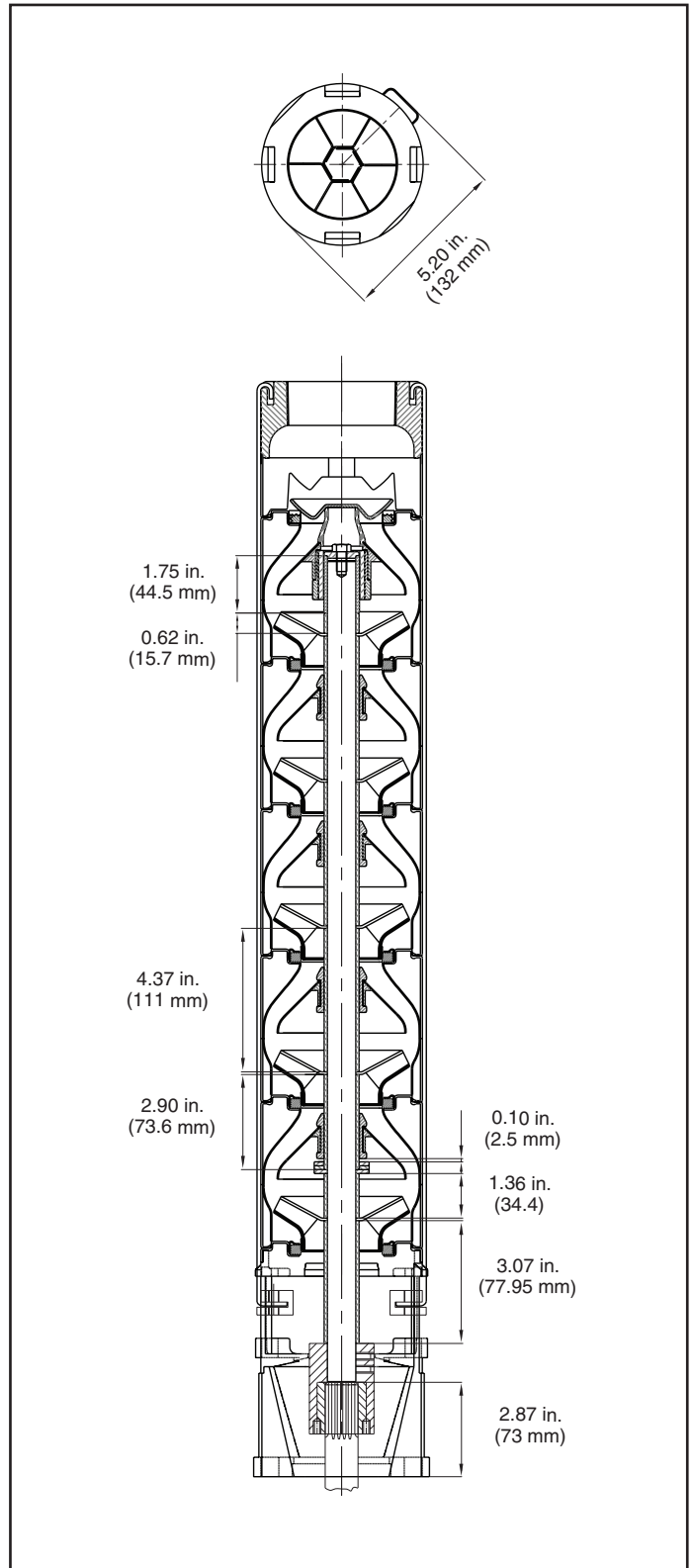

ASSEMBLY

Pump Assembly - Mixed Flow

MODEL 6TS-155 Series
4" Motor Bracket

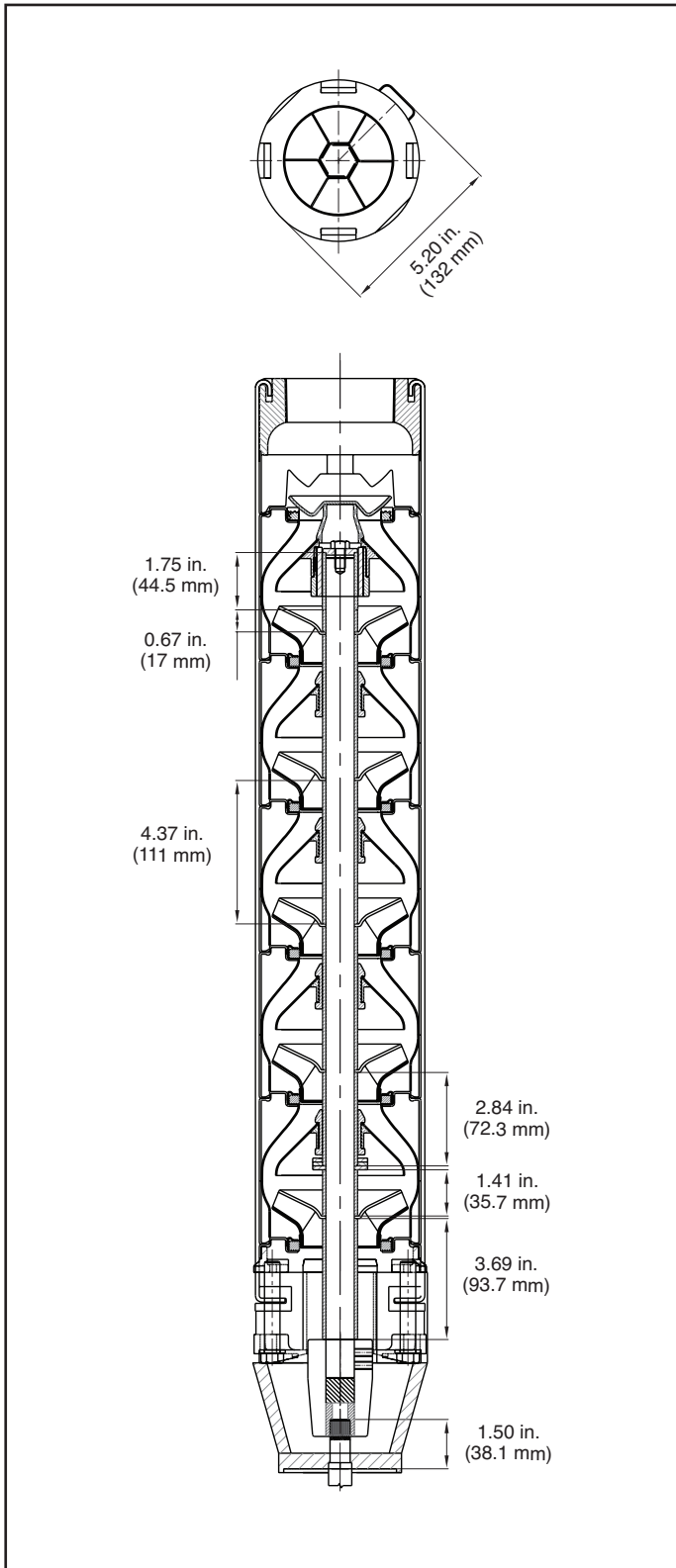

MODEL 6TS-155 Series
6" Motor Bracket

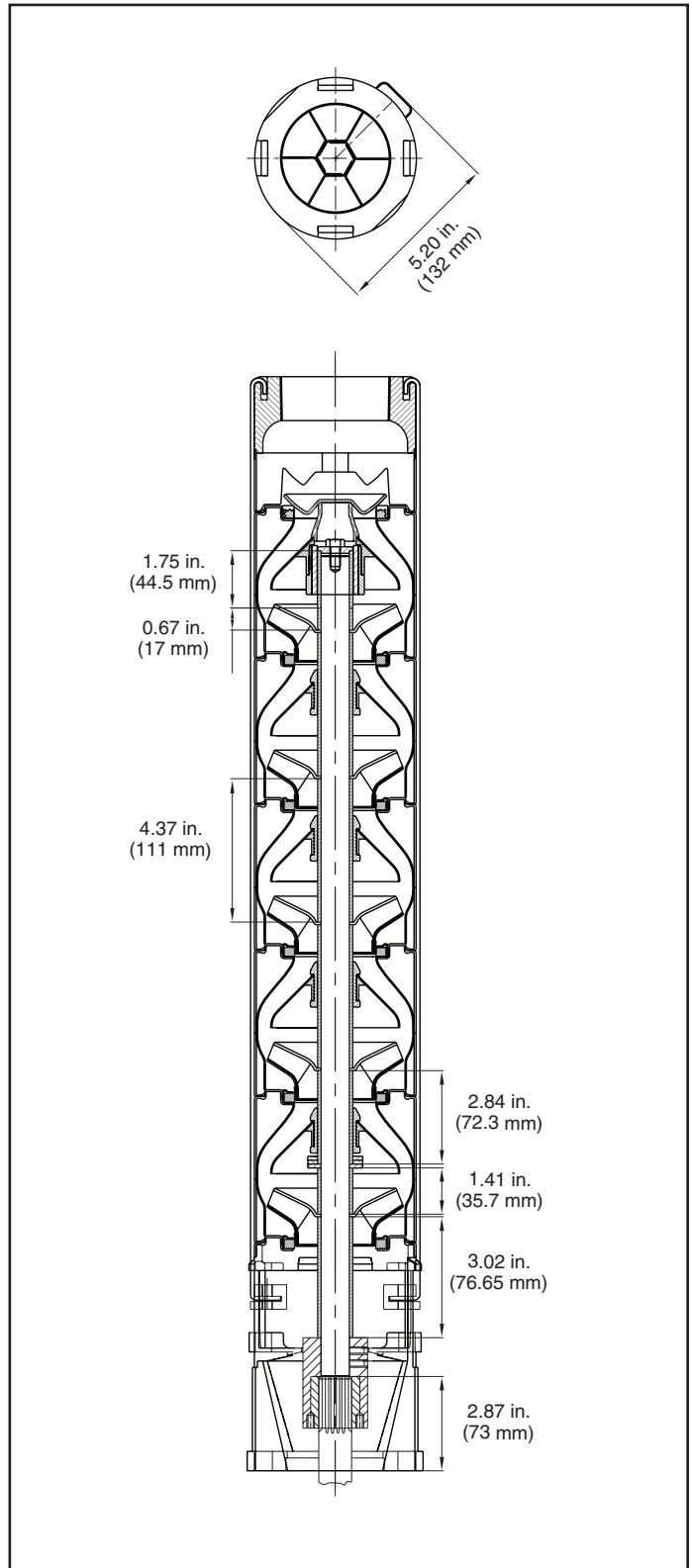

ASSEMBLY

Pump Assembly - Mixed Flow

MODEL 6TS-230 Series
4" Motor Bracket

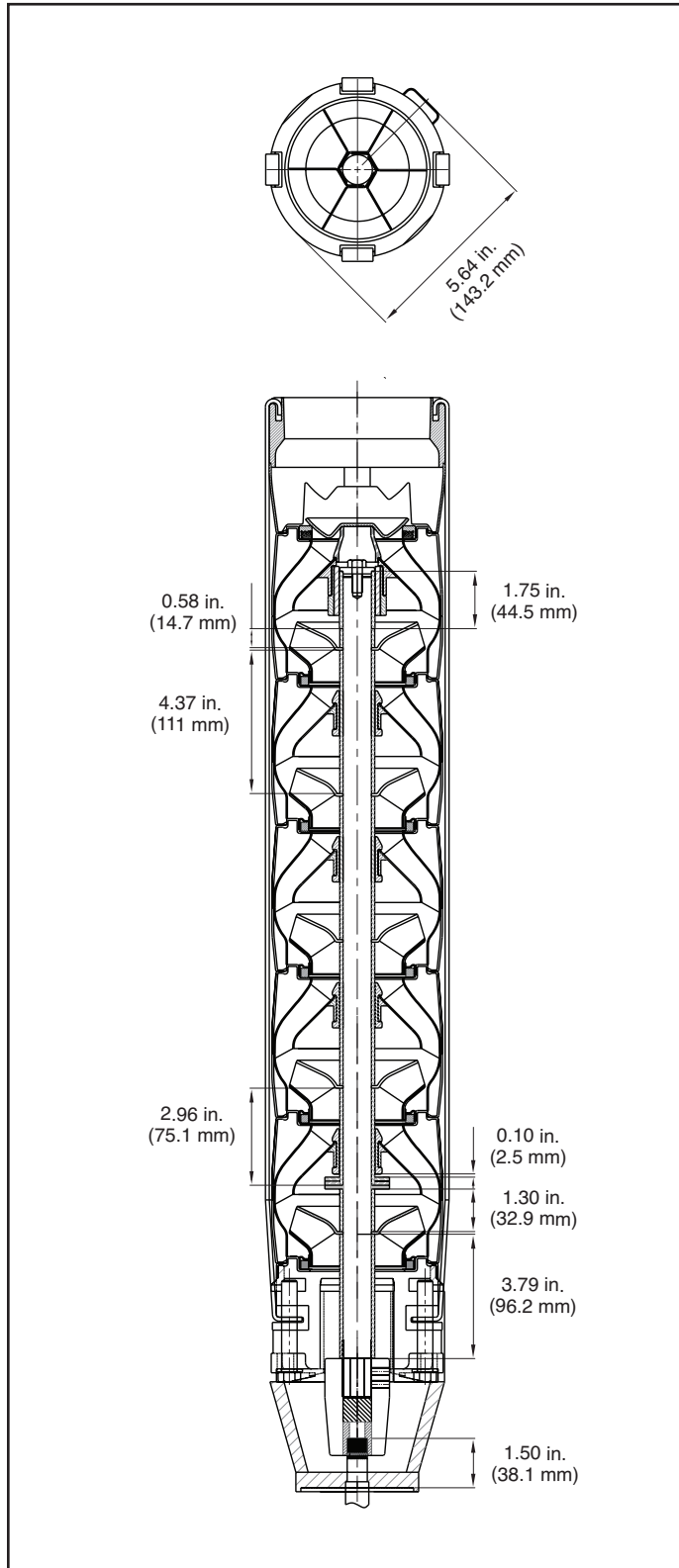

MODEL 6TS-230 Series
6" Motor Bracket

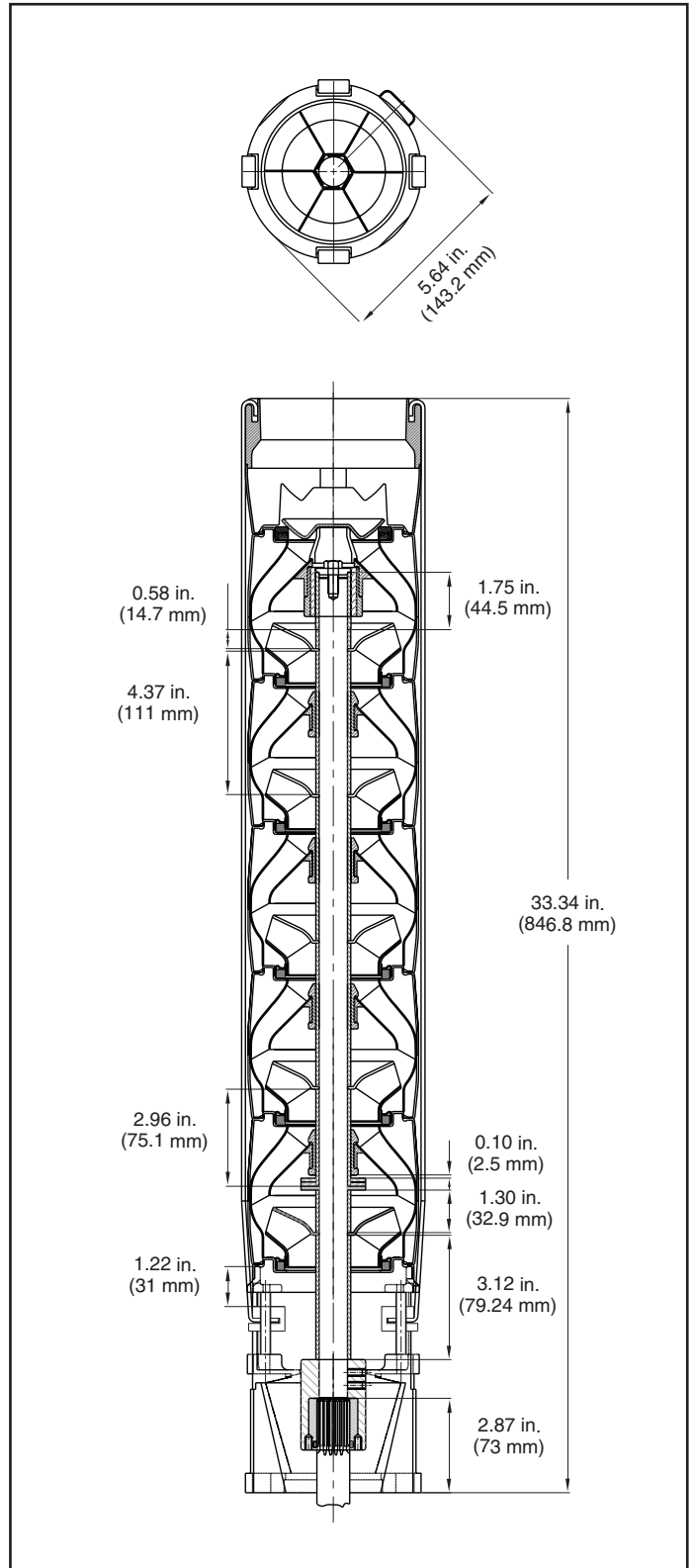

ASSEMBLY

Pump Assembly - Mixed Flow

MODEL 6TS-300 Series
4" Motor Bracket

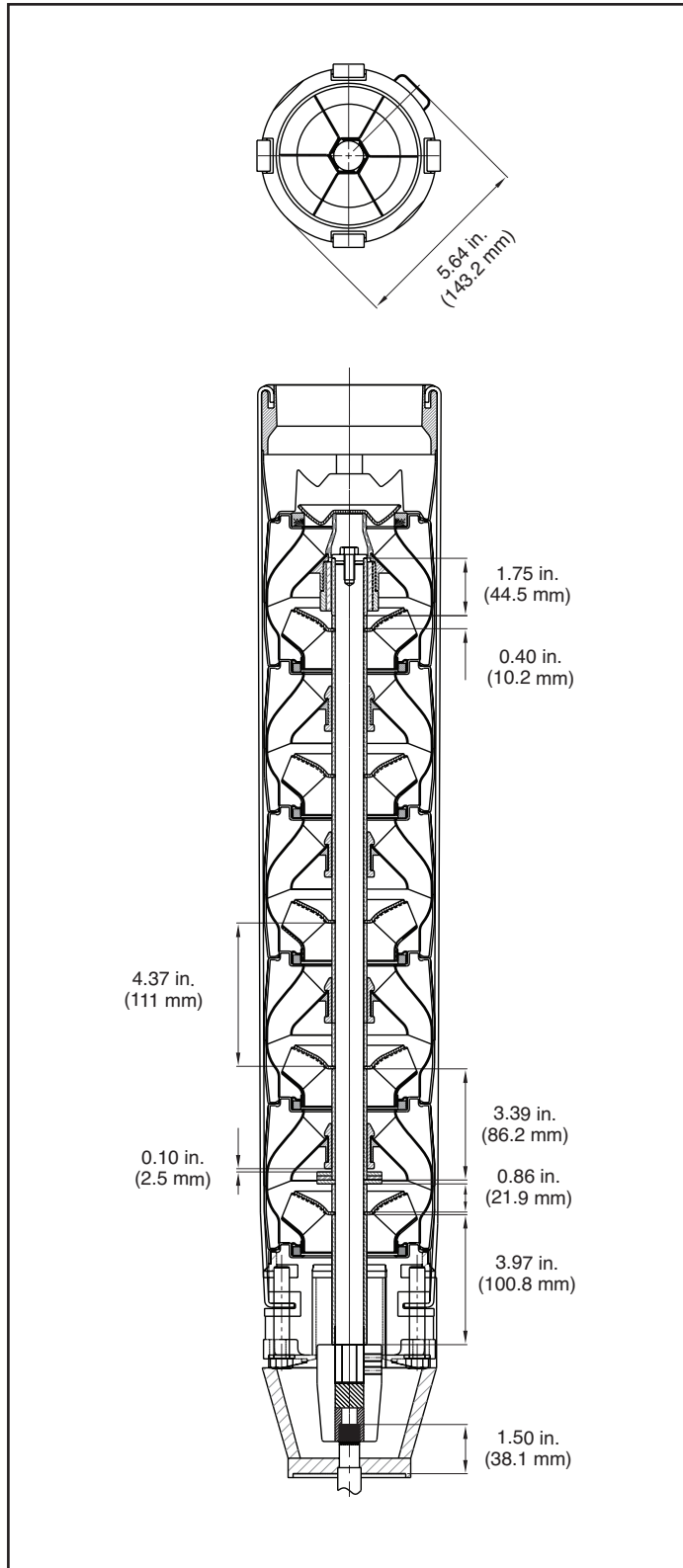

MODEL 6TS-300 Series
6" Motor Bracket

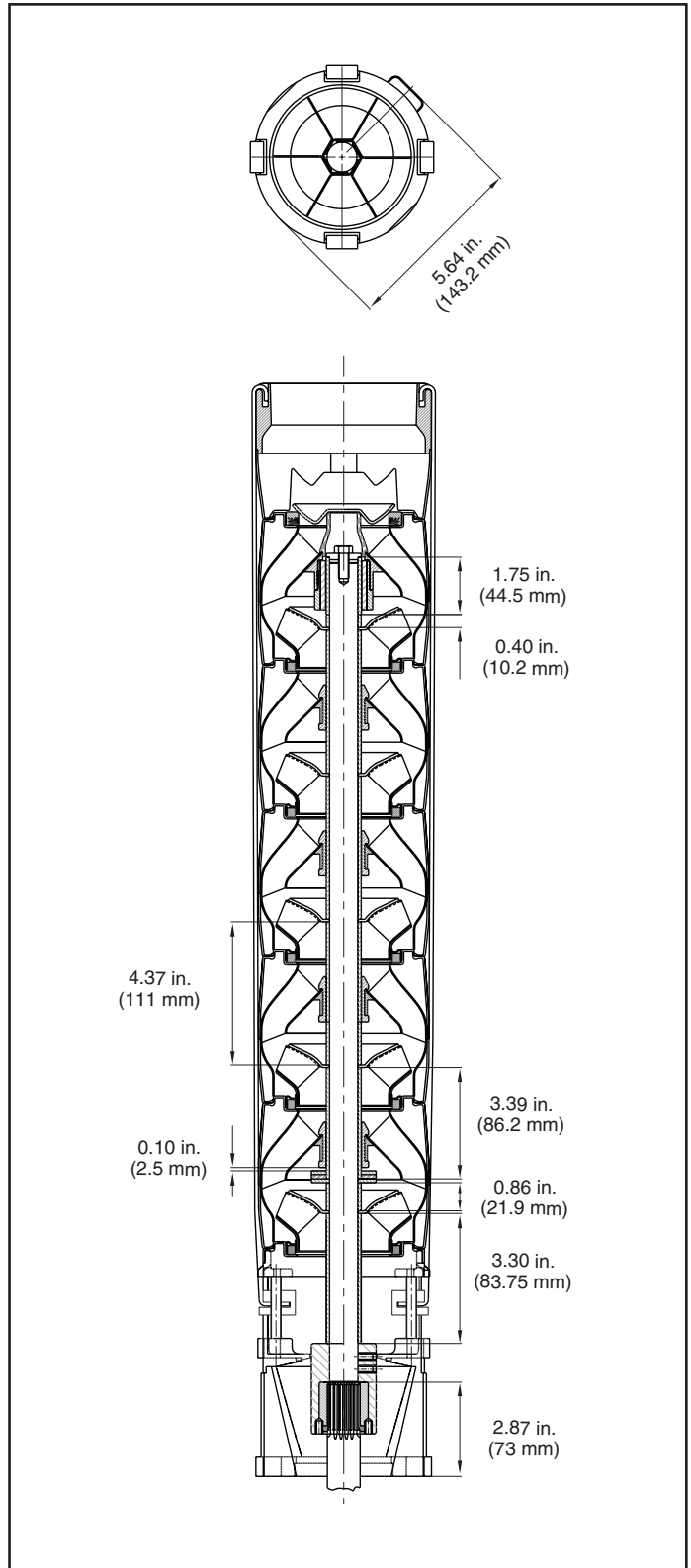

ASSEMBLY

Assembly Instructions – Shaft



Shafts supplied in Shaft/Strap/Cable-Guard – R, S, T, U, V and W Kits are supplied with one end de-burred, drilled and tapped: .31" (8 mm) dia., 1-1/4" (31.75) deep.



▶ STEP 1

Measure and cut shaft to "shaft cutoff" length, determined by pump series and pump stage count. Reference the Pump Cut-off Chart data.



▶ STEP 2

Clean shaft to remove oil and contaminants.

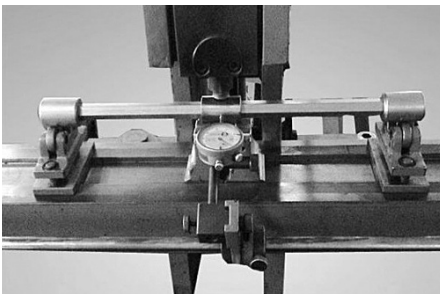

▶ STEP 3

Straighten the entire length of shaft, using Shaft Straightening Fixture Kit #5A, on a 2-ton, 1-meter deck arbor press.



▶ STEP 4

Straighten the entire length of shaft until TIR is .002" to .004" (50 to 100 microns).

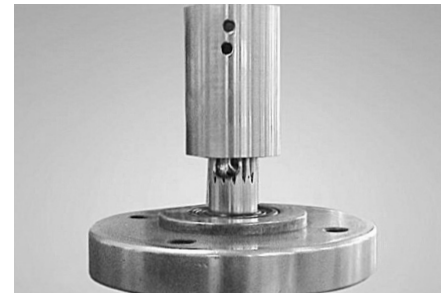

▶ STEP 5

Assemble Shaft Coupling on Shaft Coupling Fixture #6A.



▶ STEP 6

Insert shaft into coupling until shaft rests on Shaft Coupling Fixture #6A.

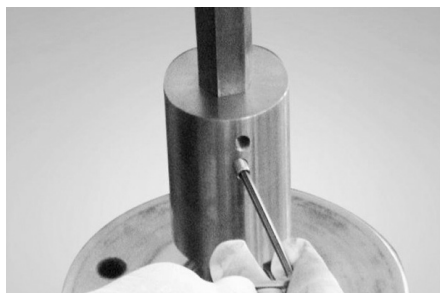

▶ STEP 7

Install one coupling set-screw. Set screw is .12" (3mm). NOTE: Will need metric Allen wrench.

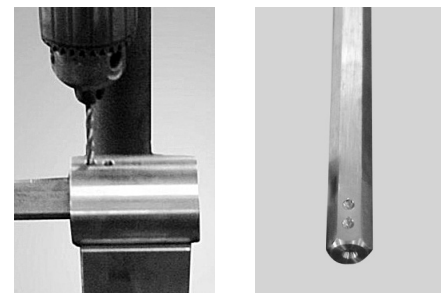

▶ STEP 8

Using a .22" (5.5mm) drill, counter-sink the shaft. Repeat steps 7 and 8 for the other coupling set-screws.



▶ STEP 9

Lock the Coupling to the Pump Shaft with both coupling set-screws and remove from Shaft Coupling Fixture #6A and assemble to pump.



▶ STEP 10

With Suction Bracket assembled to Assembly Fixture #1A, insert shaft coupling assembly on to Fixture #1A shaft spline.

ASSEMBLY

Assembly Instructions – Strap

To form L-Bend:

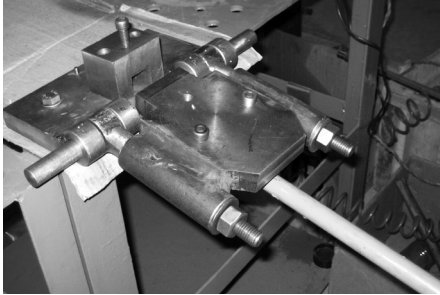

▶ STEP 1

Install bender on end of a sturdy table.

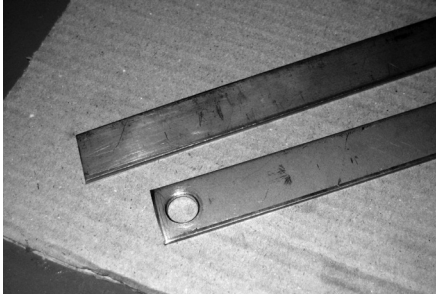

▶ STEP 2

Strap hole drilled or punched.
Cut straps to length according to cut-off charts.
De-burr. Mark position of hole according to drawings at bottom of page 62. Center punch and drill starting with 1/8" pilot hole.

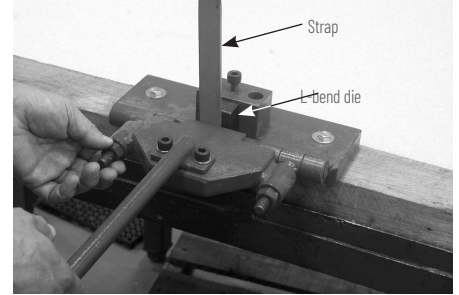

▶ STEP 3

Insert L-bend die into bender. Adjust fixture to be one strap width from L-bend die.

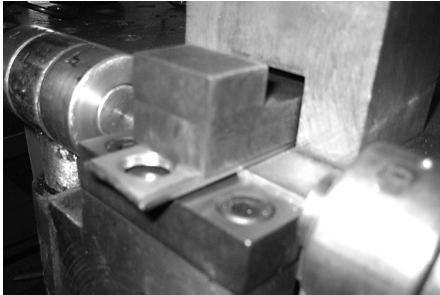

▶ STEP 4

Insert strap into bender. Insert L-bend die as shown.

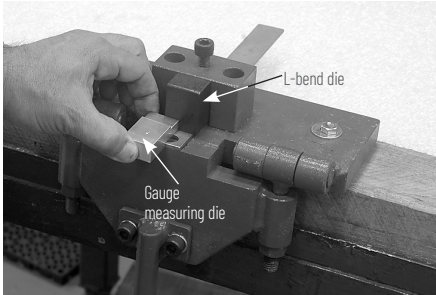

▶ STEP 5

Place gauge measuring die over straight end of strap with hole already drilled. Be sure that "L" side of die is facing down. NOTE: If using a factory-supplied strap from SSCG Kit, make sure J-bend on strap is facing up.

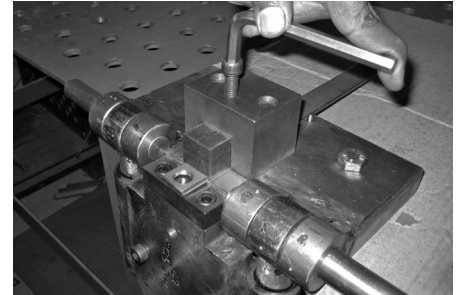

▶ STEP 6

Tighten the cap screw provided on the top of fixture. Use 5/16" Allen wrench to tighten die.



▶ STEP 6a

Strap "L" bending in progress.
Form initial bend, then repeat once again to set the bend. Double check to assure a full 90° "L" is made.

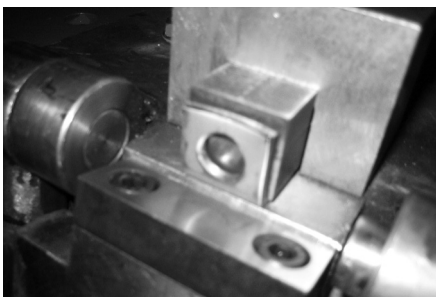

▶ STEP 7

Strap "L" bend formed.

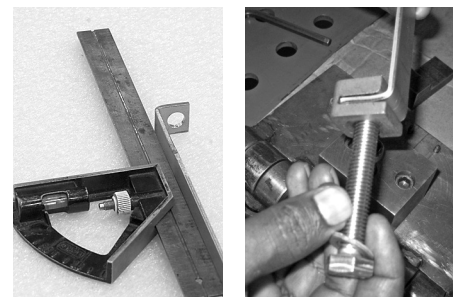

▶ STEP 7a

Using a straight edge, check that strap is straight. Make necessary adjustments. Check the formed end with Strap nut and M12 Cap Screw.

ASSEMBLY

Assembly Instructions – Strap

To form J-Bend

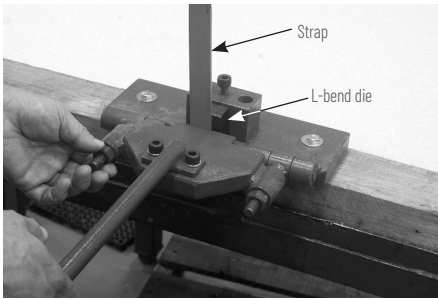

▶ STEP 1

Insert L-bend die into bender. Adjust fixture to be one strap width from L-bend die.

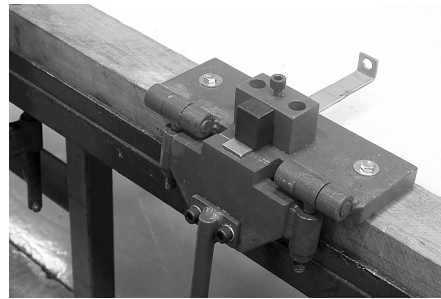

▶ STEP 2

Insert strap into bender. Insert L-bend die as shown.

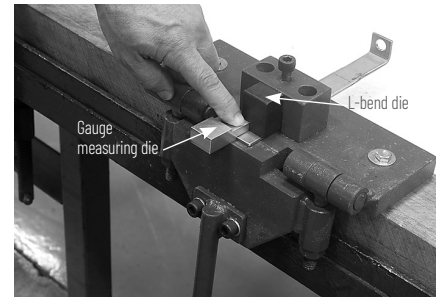

▶ STEP 3

Place gauge measuring die over undrilled end of strap. Be sure that "J" side of die is facing down.

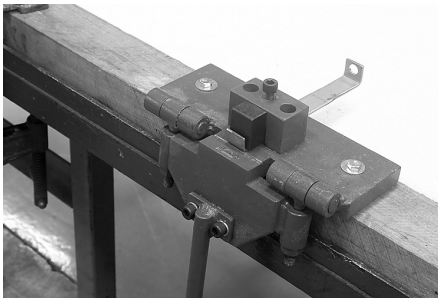

▶ STEP 4

Form initial L-bend.

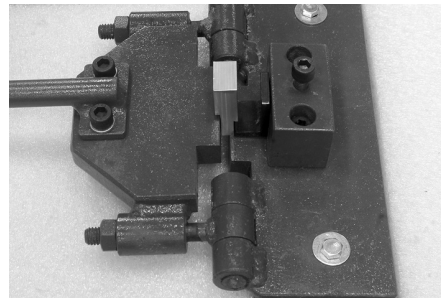

▶ STEP 5

Replace L-bend die with J-bend die and adjust fixture using gauge measuring die to be 3/8".

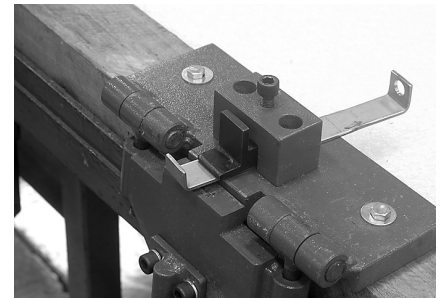

▶ STEP 6

Insert J-bend die over strap with partially bent strap.

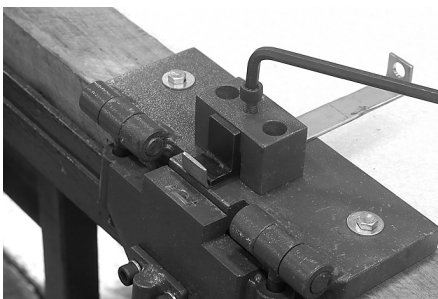

▶ STEP 7

Tighten the cap screw on top of fixture. Use 5/16" Allen wrench to tighten die.

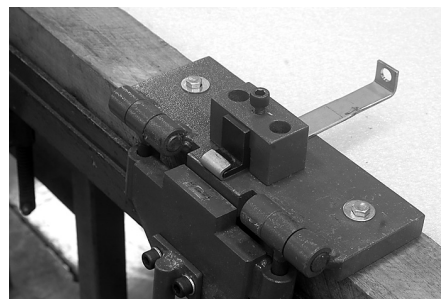

▶ STEP 8

Form initial J-bend.

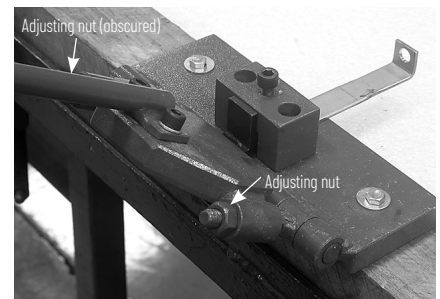

▶ STEP 9

Back both adjusting nuts off, one full turn each, and complete J-bend.

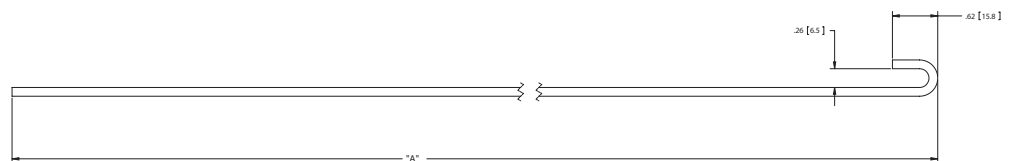
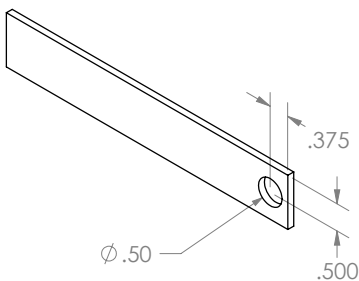

REPAIR PARTS LIST

Mixed Flow

60 Hz

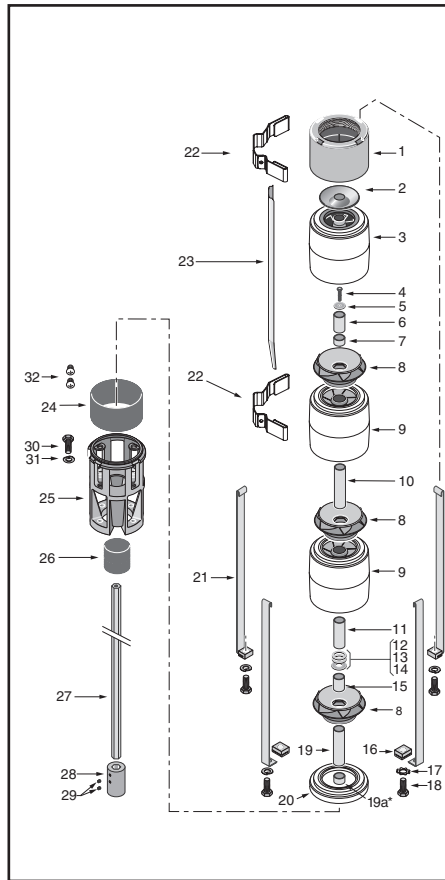

*BKT4 includes additional 17.04 mm spacer #19a (M14054); needed due to bracket length difference versus BKT6.

Repair Parts No.	Description	115 GPM	155 GPM	230 GPM	300 GPM	Qty.
1	Discharge - 3" NPT/4" NPT	M14073	M14073	M14074	M14074	1
2	Check Valve Poppet	M14070	M14070	M14070	M14070	1
3	Top Bowl	M14044	M14044	M14062	M14069	1
4	Stack Compression Capscrew	1000000582	1000000582	1000000582	1000000582	1
5	Stack Compression Washer	1000000581	1000000581	1000000581	1000000581	1
6	Bearing Journal	1000000575	1000000575	1000000575	1000000575	1
7	Discharge Shaft Spacer	M14049	M14054	M14061	M14068	1
8	Impeller	M14045	M14050	M14057	M14064	^
9	Bowl with Diffuser	M14042-B	M14042-B	M14056-B	M14063-B	^
10	Stage Spacer	M14071	M14071	M14071	M14071	^
11	Distance Sleeve	M14048	M14053	M14060	M14067	1
12	Stainless Washer	1000000579	1000000579	1000000579	1000000579	1
13	Fiber Washer	1000000580	1000000580	1000000580	1000000580	1
14	Thrust Washer	M14072	M14072	M14072	M14072	1
15	Thrust Shaft Spacer	M14047	M14052	M14059	M14066	1
16	Strap Nut	1000000590	1000000590	1000000590	1000000590	4
17	Star Lock Washer	S23038	S23038	S23038	S23038	4
18	Strap Capscrew	1000000591	1000000591	1000000591	1000000591	4
19	Inlet Shaft Spacer	M15679	M15680	M15681	M15682	1
19a	Inlet Shaft Spacer - 17.04 mm (BKT4)	M14054	M14054	M14054	M14054	1
20	First Stage Adapter	M14043-B	M14043-B	M14055-B	M14055-B	1
21	Strap	Refer to Build Charts for lengths				4
22	Cable Guard Bracket	M15699	M15699	M15699	M15699	2
23	Cable Guard	Refer to Build Charts for lengths				1
24	Suction Screen - 4" Motor Bracket and 6" NA Motor Bracket	1000000414	1000000414	1000000414	1000000414	1
	Suction Screen - 6" Global Motor Bracket	1000000414-G	1000000414-G	1000000414-G	1000000414-G	1
25	Suction Bracket - 6" NEMA Motor	M14078-G	M14078-G	M14078-G	M14078-G	1
	Suction Bracket - 4" NEMA Motor	M14077	M14077	M14077	M14077	1
26	Coupling Screen - 6" Motor Bracket	1000001566	1000001566	1000001566	1000001566	1
27	Shaft	Refer to Build Charts for lengths				1
28	Coupling - 6" NEMA Motor	M15698	M15698	M15698	M15698	1
	Coupling - 4" NEMA Motor	M15749	M15749	M15749	M15749	1
29	Coupling Set Screws	S27426	S27426	S27426	S27426	2
30, 31	4" Motor Mounting Hardware - 5/6"-24" 304SS Hex Nut (4)	B76087	B76087	B76087	B76087	1
	4" Motor Mounting Hardware - 5/6" SS Spring Lock Washer (4)					
30, 31	6" Motor Mounting Hardware - 1/2"-20" x 1-1/2" Lg Hex Head Cap Screw (4)	B69659	B69659	B69659	B69659	1
	6" Motor Mounting Hardware - 1/2" Lock Washer (4)					
32	Screws - Suction Screen	S29885	S29885	S29885	S29885	2

*Refer to total number of stages.

This page left blank intentionally.



293 Wright Street | Delavan, WI 53115 | Ph: 888.237.5353 | Orders Fax: 800.321.8793 | pentair.com

*For a detailed list of where Pentair trademarks are registered, please visit www.pentair.com/en/registrations.html. Pentair trademarks and logos are owned by Pentair PLC. or its affiliates. Third party registered and unregistered trademarks and logos are the property of their respective owners. Because we are continuously improving our products and services, Pentair reserves the right to change specifications without prior notice. Pentair is an equal opportunity employer.

B10117BK (10/09/19) ©2019 Pentair. All Rights Reserved.