

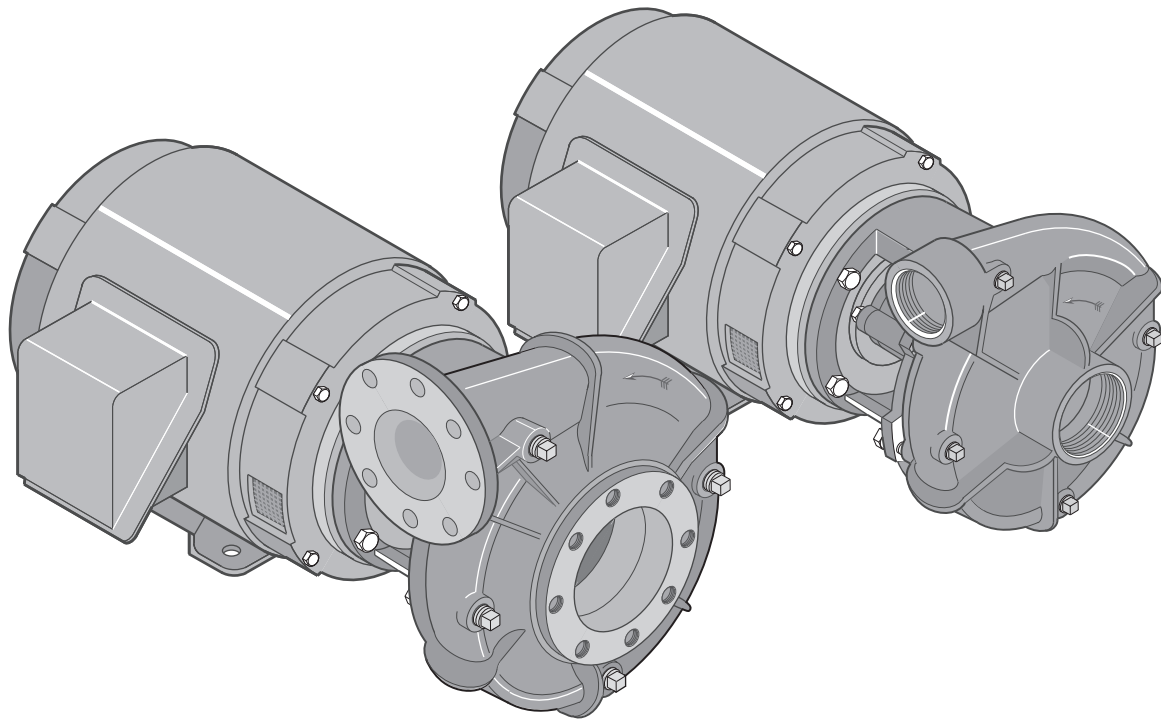

OWNER'S MANUAL  
**Closed Coupled Motor Driven  
Centrifugal Pump**

---

**BERKELEY®**



---

	Page
• <b>SAFETY</b> .....	3
• <b>INSTALLATION</b>	
General Information .....	4-5
Foundation .....	5
Centrifugal Pump Suction Connection .....	6-9
Swimming Pool Pump Suction Connection .....	10-11
Discharge Connection .....	12-13
Electrical Connection .....	14
• <b>START-UP</b>	
General Information .....	15
Determine Pump Rotation .....	16
Pump Priming .....	17
• <b>MAINTENANCE</b>	
General Information .....	18
Packing Ring Replacement .....	19
Mechanical Shaft Seal .....	20-23
• <b>PUMP NOMENCLATURE</b>	
General Information .....	24
Parts Breakdown .....	25-26
• <b>TROUBLESHOOTING</b>	
Chart .....	27
• <b>WARRANTY</b>	
Warranty .....	28

## READ AND FOLLOW SAFETY INSTRUCTIONS!

**⚠ This is the safety alert symbol.** When you see this symbol on your pump or in this manual, look for one of the following signal words and be alert to the potential for personal injury:

**⚠ DANGER** warns about hazards that **will** cause serious personal injury, death or major property damage if ignored.

**⚠ WARNING** warns about hazards that **will** or **can** cause serious personal injury, death or major property damage if ignored.

**⚠ CAUTION** warns about hazards that **will** or **can** cause minor personal injury or property damage if ignored.

The label **NOTICE** indicates special instructions which are important but not related to hazards.

**Carefully read and follow all safety instructions in this manual and on pump.**

Keep safety labels in good condition.

Replace missing or damaged safety labels.

### Electrical Safety

**⚠ WARNING**



**Hazardous voltage. Can shock, burn, or cause death.**

Ground pump before connecting to power supply.

**⚠ Wire motor for correct voltage.** See “Electrical” section of this manual and motor nameplate.

**⚠ Ground motor before connecting to power supply.**

**⚠ Meet National Electrical Code and local codes for all wiring.**

**⚠ Follow wiring instructions in this manual when connecting motor to power lines.**

### General Safety

Do not allow pump, piping, or any other system component containing water to freeze. Freezing may damage system, leading to injury or flooding. Allowing pump or system components to freeze will void warranty.

Pump approved liquids only with this pump.

Periodically inspect pump and system components.

Wear safety glasses at all times when working on pumps.

Keep work area clean, uncluttered and properly lighted; store properly all unused tools and equipment.

Keep visitors at a safe distance from the work areas.

Make workshops childproof; use padlocks and master switches; remove starter keys.

### Swimming Pool and Spa Installation Safety

**⚠ WARNING**

Hazardous pressure

**Incorrectly installed or tested equipment may fail, causing severe injury or property damage.**

Read and follow instructions in owner’s manual when installing and operating equipment. Have a trained pool professional perform all pressure tests.

1. Do not connect system to a high pressure or city water system.
2. Install pump with at least 2 hydraulically balanced main drains equipped with correctly installed, screw-fastened, anti-entrapment certified covers. See Page 11.
3. Trapped air in system can cause explosion. **BE SURE** all air is out of system before operating or testing equipment.

**Before pressure testing, make the following safety checks:**

- Check all clamps, bolts, lids, and system accessories before testing.
- Release all air in system before testing.
- Tighten Berkeley trap lids to 30 ft. lbs. (4.1 kg-cm) torque for testing.
- Water pressure for test must be less than 25 PSI (172 kPa).
- Water Temperature for test must be less than 100° F. (38° C).
- Limit test to 24 hours. After test, visually check system to be sure it is ready for operation. Remove trap lid and retighten hand tight only.

**NOTICE:** These parameters apply to Berkeley equipment only. For non-Berkeley equipment, consult manufacturer.

## General Information

**⚠️ WARNING** Heavy weight crushing hazard. NEVER walk or reach under a suspended pump.

DO NOT screw an eye bolt into the motor housing and attempt to lift assembly! The lifting point built into the motor case is not designed to support the combined weight of the motor and pump.

The crane or hoist must have a capacity in excess of the combined weight of the motor and pump. Use a minimum of two chains or straps to lift motor/pump assembly. Each chain or strap must have a capacity in excess of the combined weight of the motor and pump.

## MOTOR / PUMP LIFTING PROCEDURE:

Wrap the first chain or strap under the fan end of the motor up tight against the motor feet, and the second chain or strap under the pump bracket between the pump end and the motor.

Raise motor/pump assembly slowly to ensure that the chains or straps will not slip when put under tension. Balance motor and pump with chains or straps to maintain proper weight distribution. If not balanced, release tension on the chains or straps and readjust.



## General Information

### LOCATION:

Locate the pump as near the water source as practical. Make the pipe run as short and straight as possible, especially if a suction lift is required.

Careful attention should be taken to assure that net positive suction head available (NPSHA) exceeds net positive suction head required (NPSHR) by the pump or reduced performance and severe pump damage may result. If in doubt, check with your nearest Berkeley professional dealer. Install pump in a clean, dry and drained location readily accessible for inspection and maintenance. Provide ample ventilation.

### FOUNDATION: Refer to illustrations at right.

**⚠ WARNING Heavy weights.** Use care and proper equipment when handling pump for installation. Pump should be set on a concrete foundation which is sufficiently substantial to absorb vibration and which provides a permanent and rigid support.

### PIPING:

System piping should be at least one commercial pipe size larger than pump connections and flow velocity should not exceed eight (8) feet per second. In pool installation, flow velocity should not exceed six (6) feet per second.

**NOTICE:** Take care to align piping with pump case. Misalignment or excessive pipe strain can cause distortion of pump components resulting in rubbing, breakage and reduced pump life.

Support pipe in such a way that no force is exerted on pump connections. Check alignment as follows: with the pump shut down and isolation valves closed, remove pipe flange bolts. If the mating flanges come apart or shift, misalignment is present and causing pressure on the connections. Adjust pipe supports until flanges mate without any force. This procedure can be done throughout piping system.

### SUCTION PIPING:

Refer to Pages 10 and 11 for installation instructions for swimming pool circulating pump applications. Refer to Pages 6 through 9 for recommended and not recommended practices in suction connections in centrifugal installations.

### DISCHARGE PIPING:

Refer to illustrations on Page 12 and 13 for recommended and not recommended practices in discharge connections.

### ELECTRICAL CONNECTION:

**⚠ WARNING Hazardous voltage. Can shock, burn, or cause death. All wiring should be done by a qualified electrician.** Disconnect power to pump before servicing.

Check voltage and phase stamped on pump motor nameplate before wiring. Be sure they agree with your electric current supply. They **MUST** be the same. If in doubt, check with your local power company.

Refer to illustration on Page 14 for minimum recommended pumping panel components that help safeguard your pump during operation.

## Pump Foundation

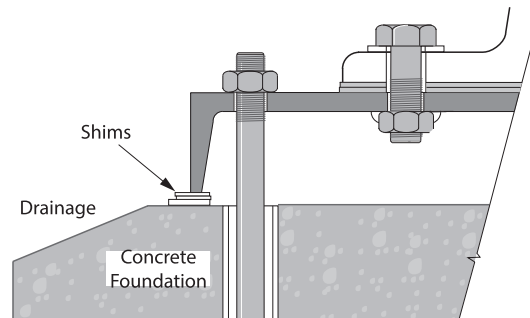
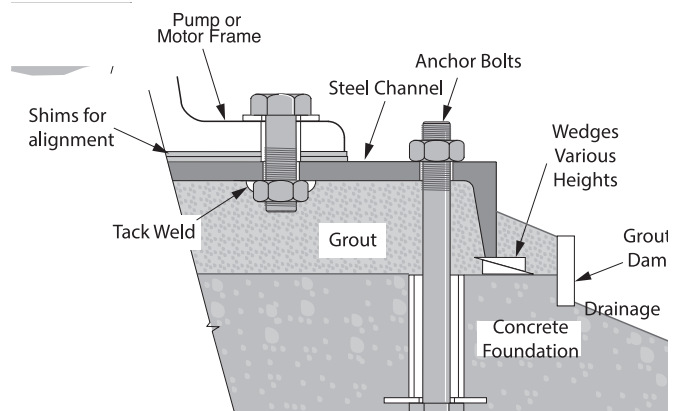
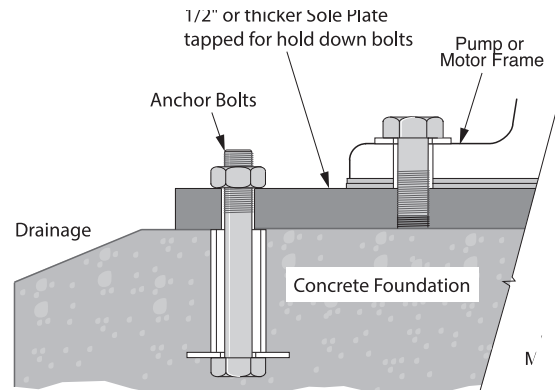

- There are several types of permanent pump/ foundation installations in use. Those pictured above are typical.
- If grout is used, top of concrete should be left rough to provide a good bonding surface.
- Foundation should slope away from pump to prevent liquid from pooling.

## SUCTION LIFT

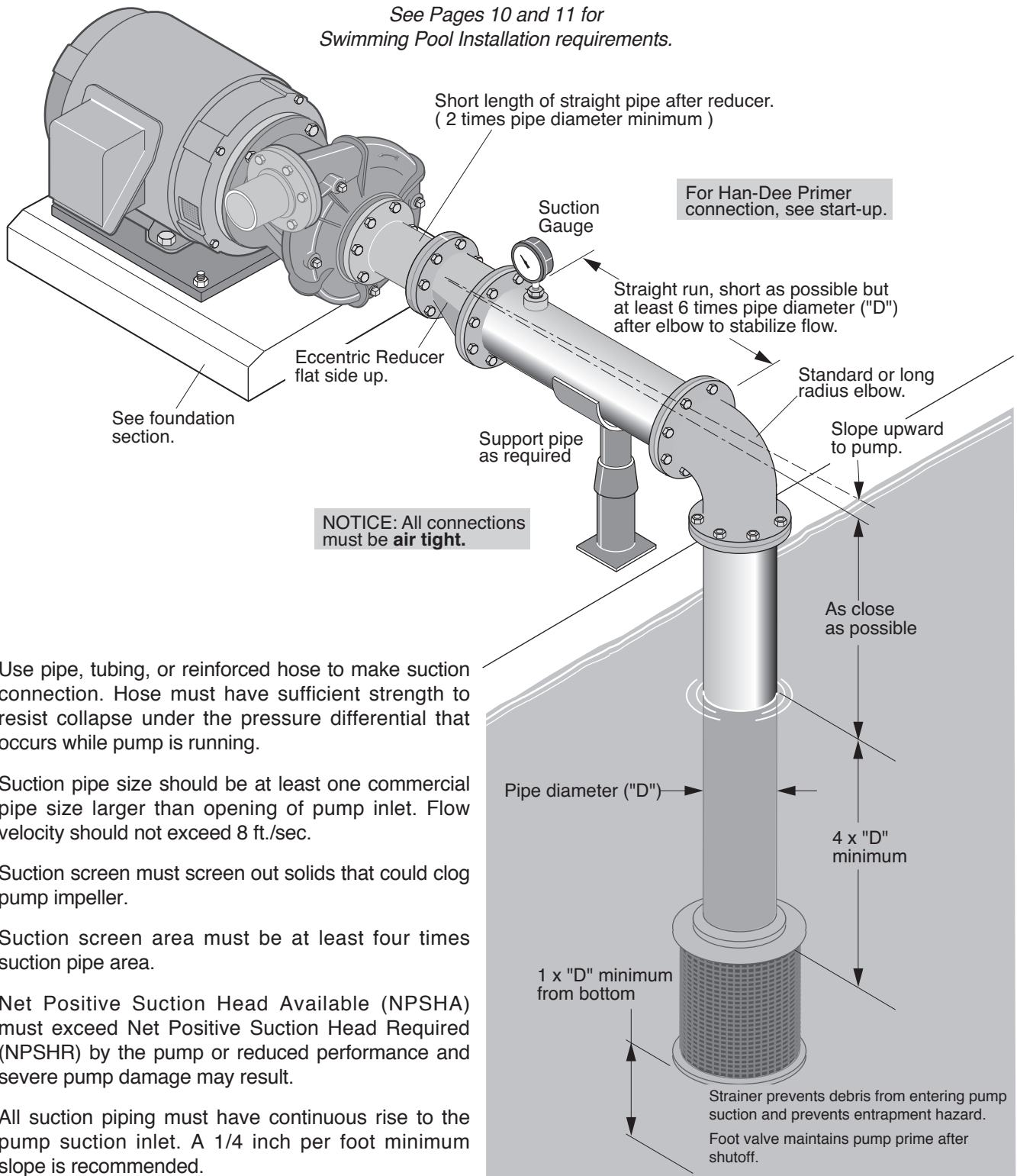

- Use pipe, tubing, or reinforced hose to make suction connection. Hose must have sufficient strength to resist collapse under the pressure differential that occurs while pump is running.
- Suction pipe size should be at least one commercial pipe size larger than opening of pump inlet. Flow velocity should not exceed 8 ft./sec.
- Suction screen must screen out solids that could clog pump impeller.
- Suction screen area must be at least four times suction pipe area.
- Net Positive Suction Head Available (NPSHA) must exceed Net Positive Suction Head Required (NPSHR) by the pump or reduced performance and severe pump damage may result.
- All suction piping must have continuous rise to the pump suction inlet. A 1/4 inch per foot minimum slope is recommended.

# Recommended

## SUCTION LIFT

See Pages 10 and 11 for  
Swimming Pool Installation requirements.

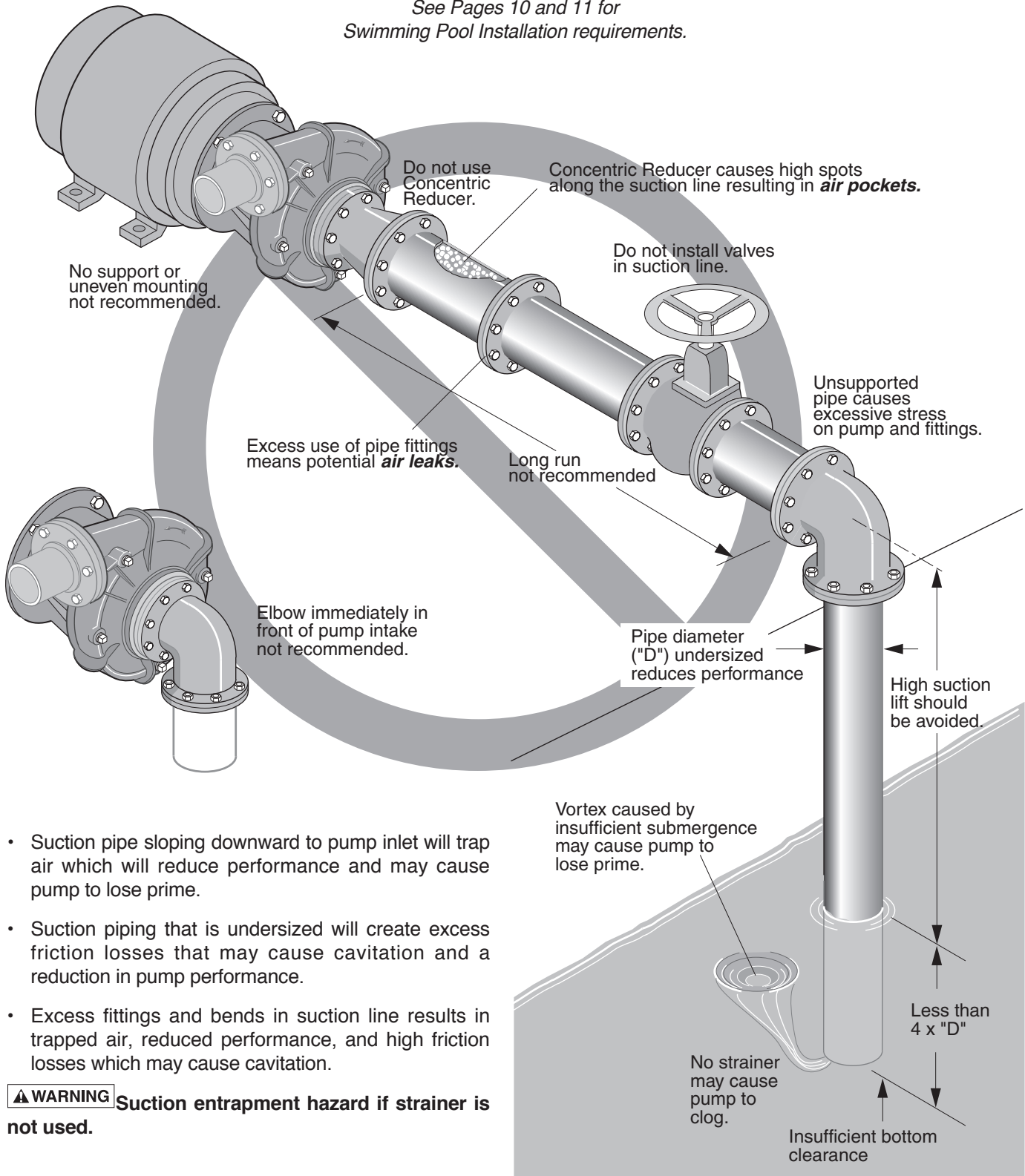

- Suction pipe sloping downward to pump inlet will trap air which will reduce performance and may cause pump to lose prime.
- Suction piping that is undersized will create excess friction losses that may cause cavitation and a reduction in pump performance.
- Excess fittings and bends in suction line results in trapped air, reduced performance, and high friction losses which may cause cavitation.

**⚠ WARNING** Suction entrapment hazard if strainer is not used.

**⊘ Not Recommended ⊘**



## WHEN FLOODED SUCTION EXISTS

See Pages 10 and 11 for  
Swimming Pool Installation requirements.

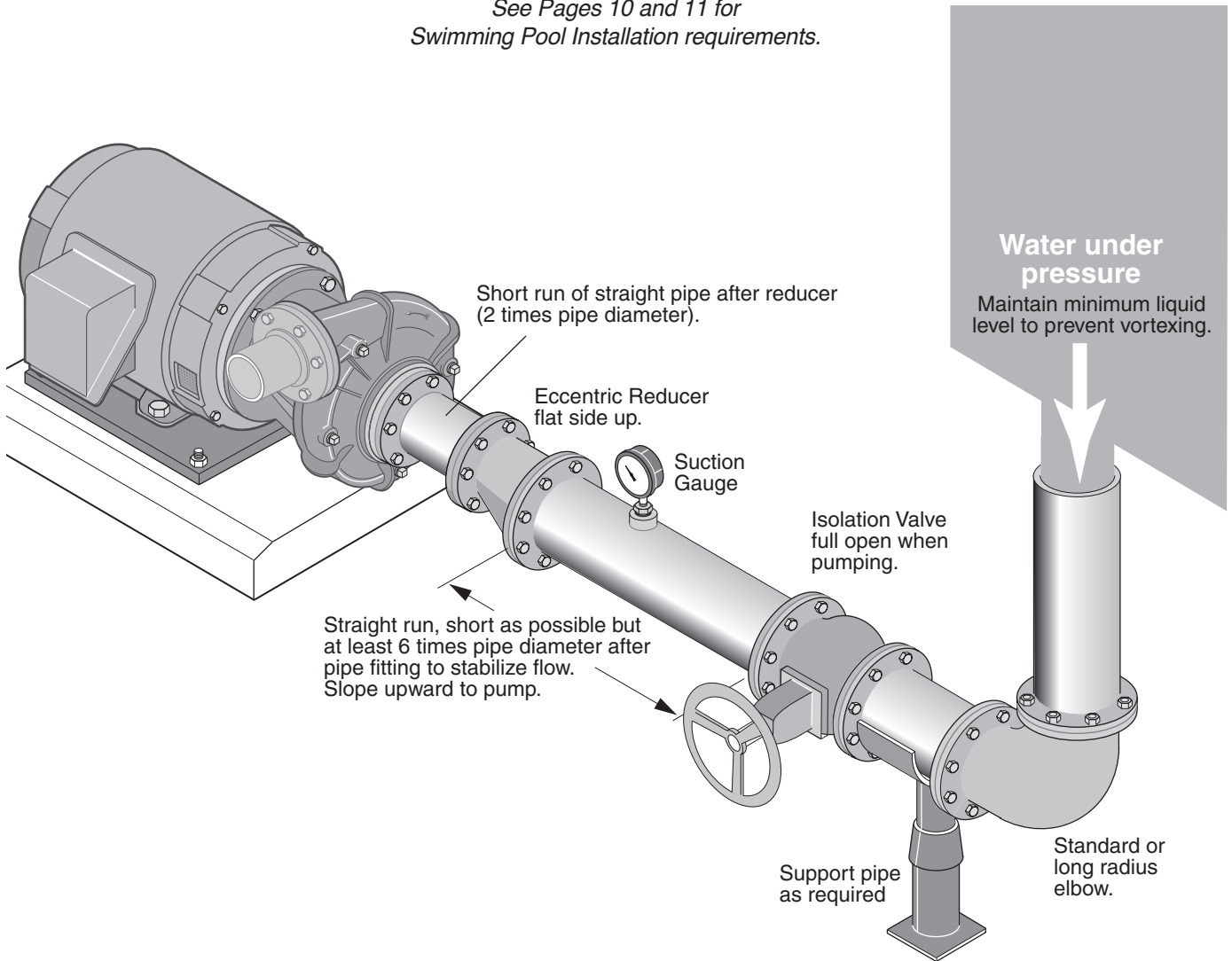

702 0294

- Use pipe, tubing, or reinforced hose to make suction connection. Hose must have sufficient strength to resist collapse under the atmospheric pressure differential that may occur while pump is running.
- It is important, even with a flooded suction condition, that proper pipe fittings are used so water is delivered to impeller eye with a smooth flow and consistent velocity.
- Suction pipe size should be at least one commercial pipe size larger than opening of pipe inlet. Flow velocity should not exceed 8 ft./sec.
- An isolation valve is used in a pressurized suction pipe to permit servicing pump.
- Piping run and connection fittings should be properly aligned and independently supported to reduce strain on pump case.
- If solids are present, a strainer should be used to protect the pump.

# Recommended



## WHEN FLOODED SUCTION EXISTS

See Pages 10 and 11 for  
Swimming Pool Installation requirements.

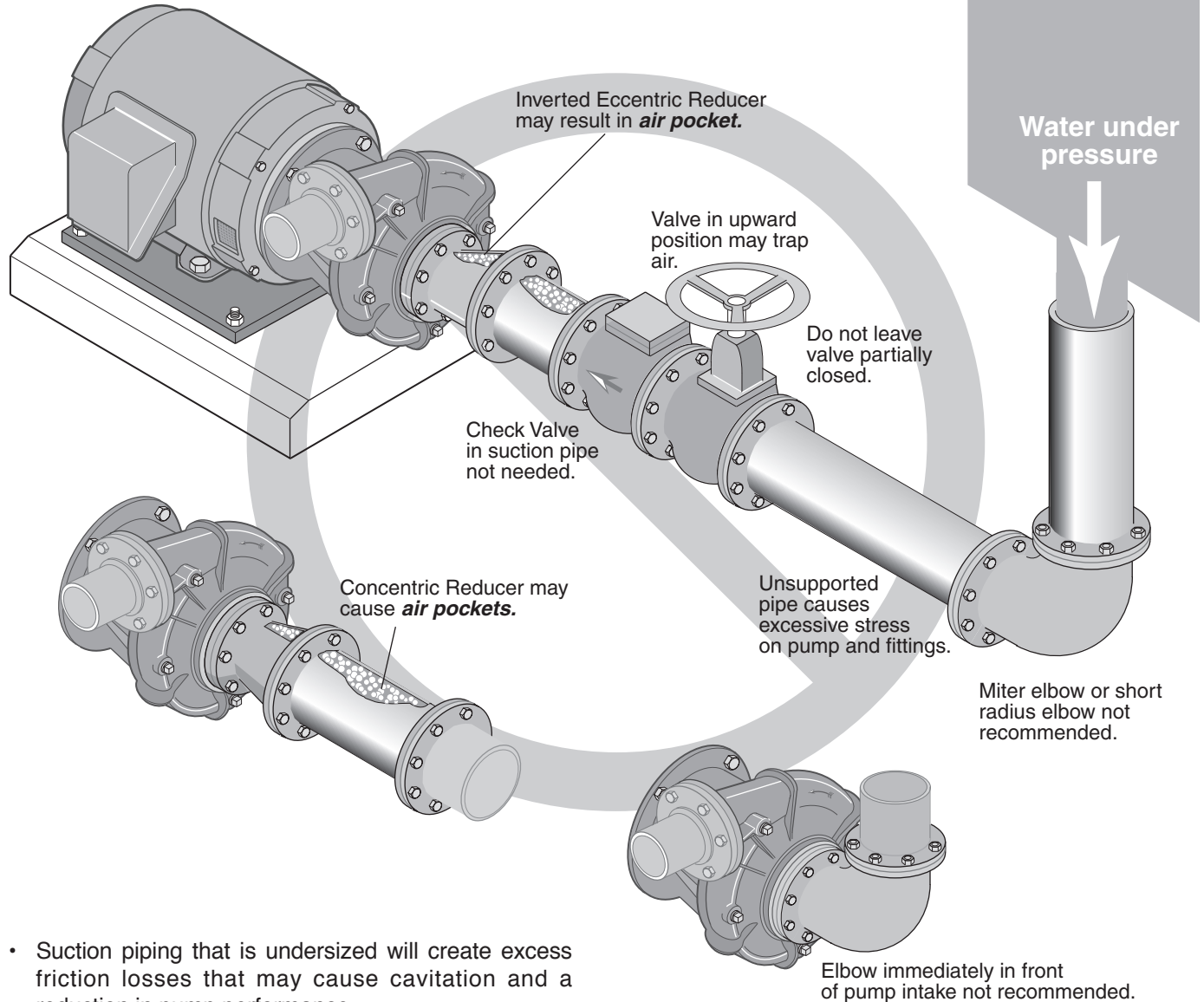

- Suction piping that is undersized will create excess friction losses that may cause cavitation and a reduction in pump performance.
- Excess fittings and bends in suction line results in trapped air, reduced performance, and high friction losses which may cause cavitation.
- If check valve is required for back flow prevention, locate on the discharge side of pump.

703 |

**⊘ Not Recommended ⊘**

## TYPICAL SWIMMING POOL

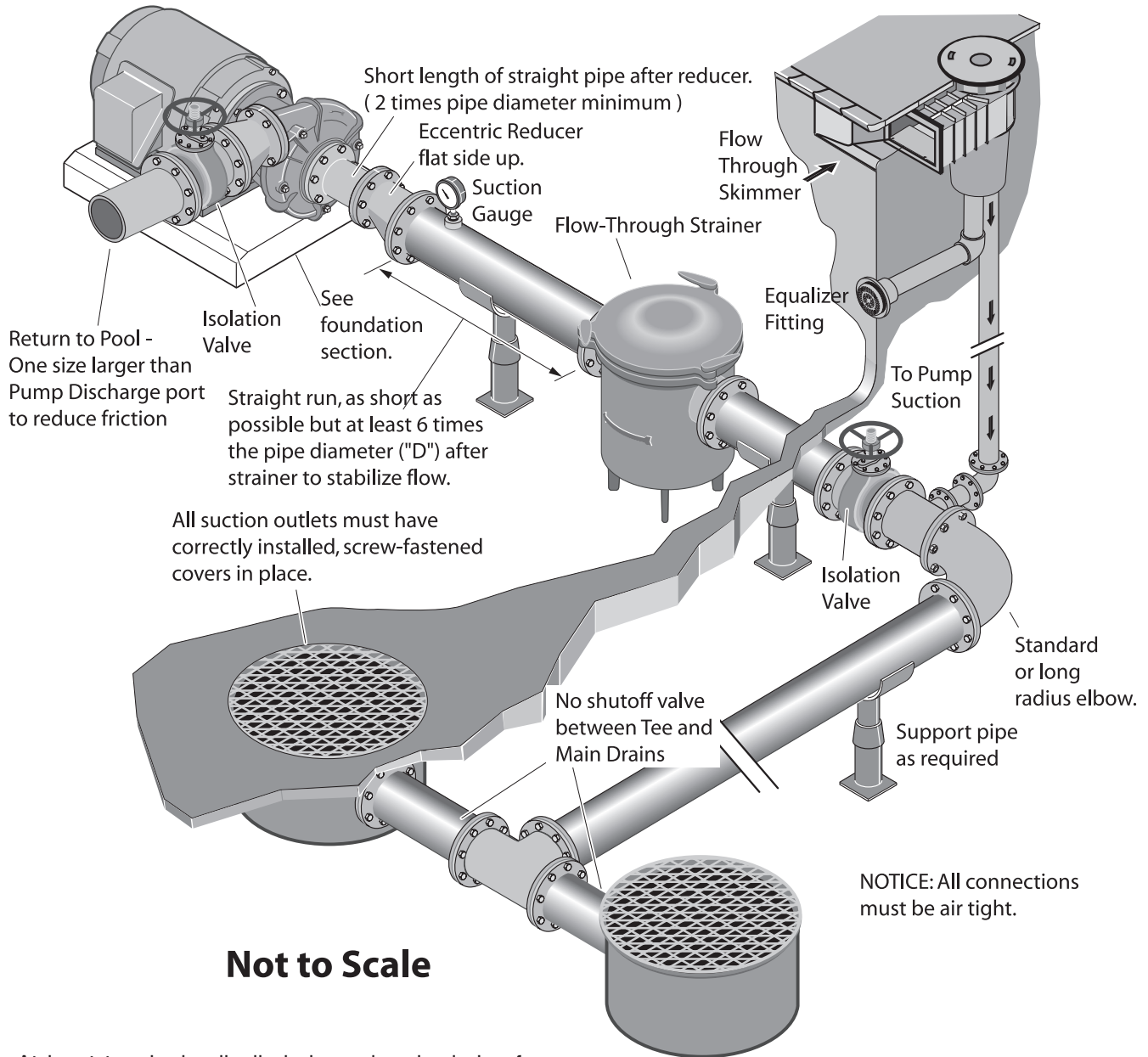

**Not to Scale**

- At least two hydraulically balanced main drains for each pump suction line. Main drain must be at least three feet center to center.
- The pump suction system *must* provide protection against the hazard of suction entrapment or hair entrapment/entanglement. All suction outlet covers must be maintained. They must be replaced if cracked, broken, or missing.
- If 100% of the pump's flow comes from the main drain system, the maximum water velocity in the pump suction hydraulic system must be six feet per second or less even if one main drain (suction fitting) is completely blocked.
- The system must not be able to operate with the pump drawing water from only *one* main drain (that is, there must be at least two main drains connected to the pump whenever it is running.) However, if two main drains run into a single suction line, the single suction line may be equipped with a valve which will shut off *both* main drains from the pump.

3080 1097

## SUCTION REQUIREMENT

**⚠ WARNING** Pump suction is hazardous and can trap and drown or disembowel bathers. Do not use or operate swimming pools, spas, or hot tubs if a suction outlet cover is missing, broken, or loose. Follow the guidelines below for a pump installation which minimizes risk to users of pools, spas, and hot tubs.

### Entrapment Protection

The pump suction system *must* provide protection against the hazard of suction entrapment or hair entrapment/entanglement.

### Suction Outlet Covers

All suction outlet covers must be maintained. They must be replaced if cracked, broken, or missing.

All suction outlets must have correctly installed, screw-fastened covers in place.

### Testing and Certification

Suction outlet covers must have been tested by a nationally recognized testing laboratory and found to comply with the latest ASME/ANSI Specification for Suction Fittings For Use in Swimming Pools, Spas, Hot Tubs, and Whirlpool Bathtub Applications.

An NSF certified hair and lint strainer must be installed with the pump in order to comply with NSF Standard 50.

### Outlets Per Pump

Provide at least two hydraulically balanced main drains, with covers (see Page 10), for each swimming pool pump suction line. The centers of the main drains (suction fittings) must be at least three feet apart.

The system must be built so that it cannot operate with the pump drawing water from only one main drain (that is, there must be at least two main drains connected to the pump whenever it is running). However, if two main drains run into a single suction line, the single suction line may be equipped with a valve which will shutoff both main drains from the pump.

More than one pump can be connected to a single suction line as long as the requirements above are met.

### Water Velocity

The maximum water velocity through any suction outlet must be 1.5 feet per second. In any case, do not exceed the suction fitting's maximum designed flow rate.

If 100% of the pump's flow comes from the main drain system, the maximum water velocity in the pump suction hydraulic system must be six feet per second or less even if one main drain (suction fitting) is completely blocked.

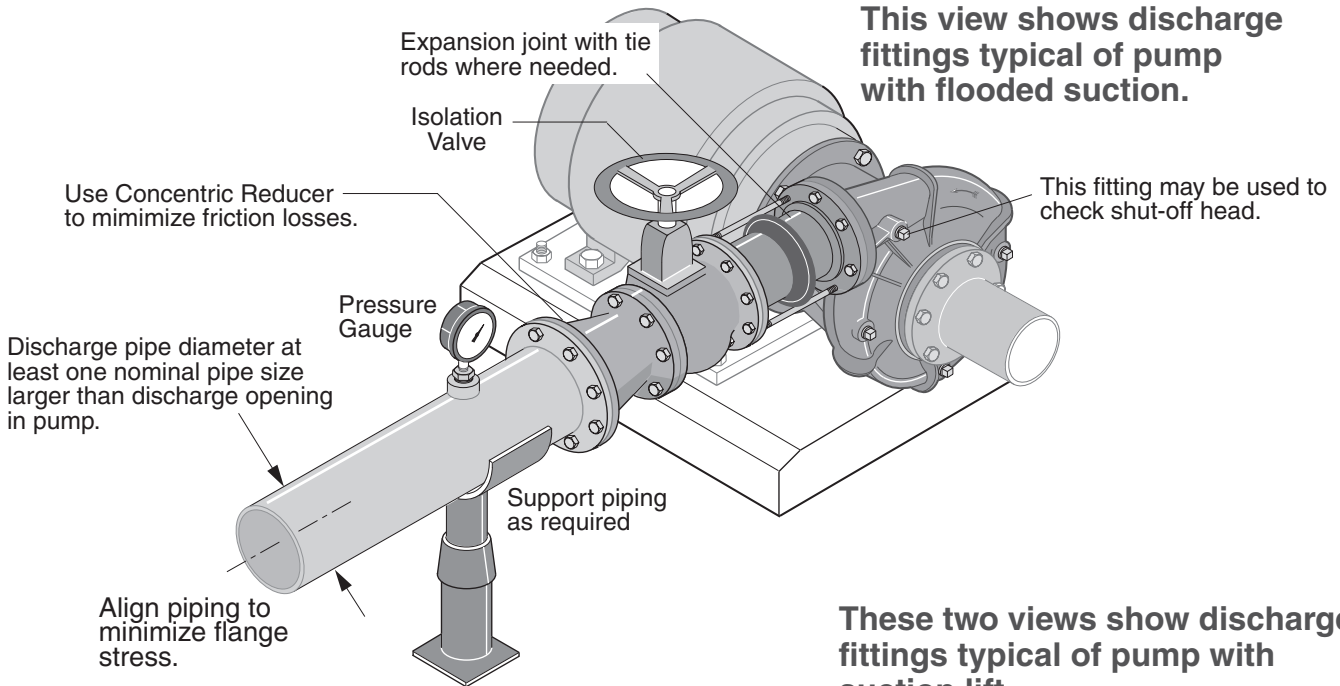

These two views show discharge fittings typical of pump with suction lift.

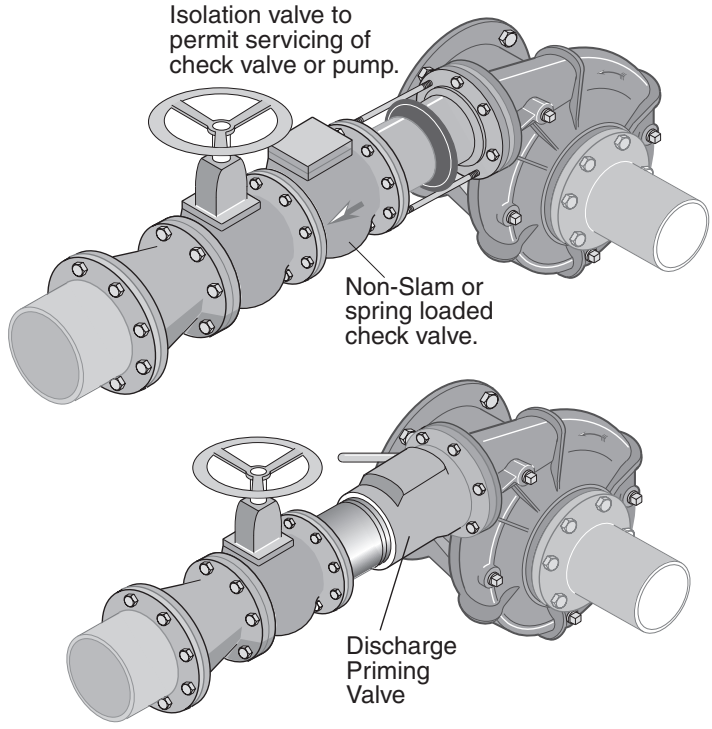

- Use pipe, tubing or reinforced hose to make discharge connection. Material selected must have sufficient strength for operating pressures.
- Discharge pipe should be sized so that flow velocity is below 8 feet per second.
- Use **ONLY** non-slamming check valves to prevent hydraulic shock (water hammer).
- Use gate, ball, or butterfly valve for isolation. Valve should be full open during operation.
- Maintain proper pipe size throughout discharge system, using as few elbows and tees as possible to keep friction loss to a minimum.
- Install pressure gauge after reducer as shown to check operating pressure or shut-off head.

706 0294

# Recommended

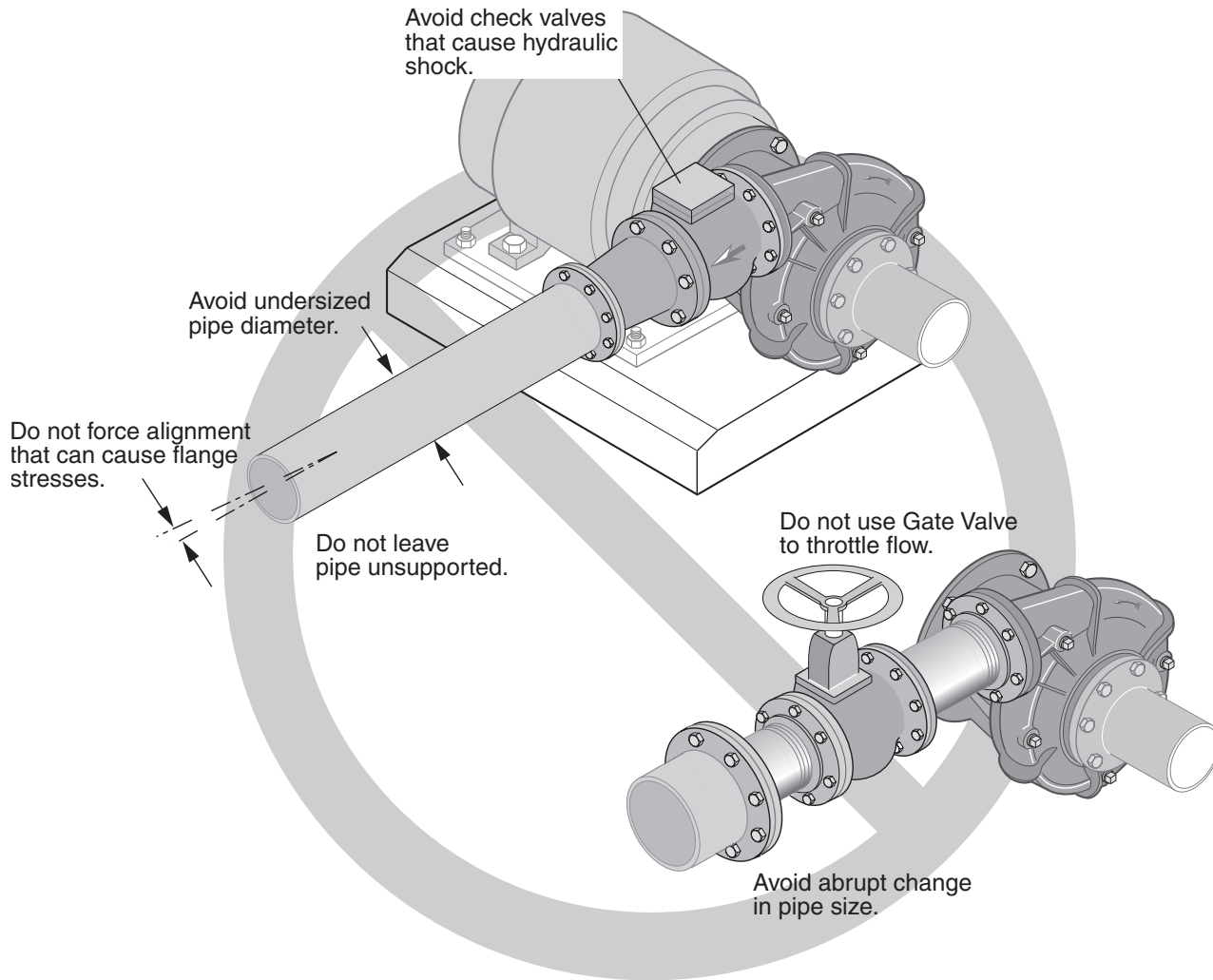

708 0294

- Avoid excess friction loss caused by numerous fittings, insufficient pipe diameter, and sharp turns in pipe run.
- Swing type check valves can permit build-up of reverse velocity before closing causing hydraulic shock or “water hammer.”

**⊘ Not Recommended ⊘**

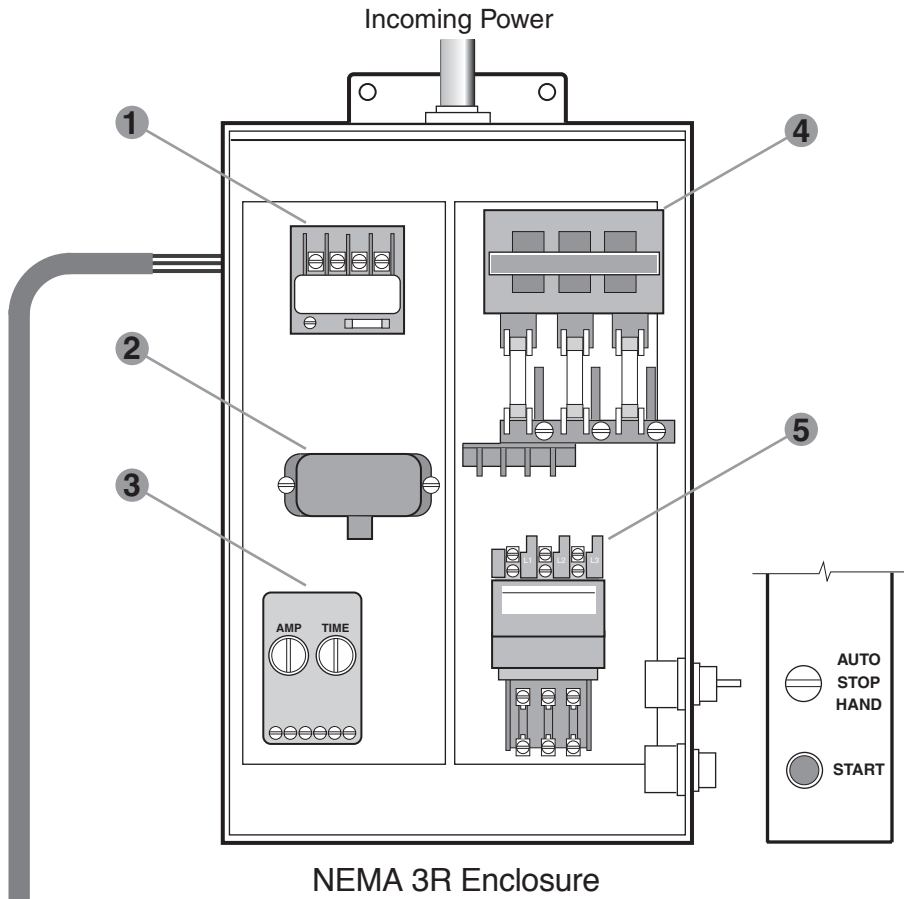

Minimum recommended components to protect your pump during operation. Check all local electrical codes prior to installation.

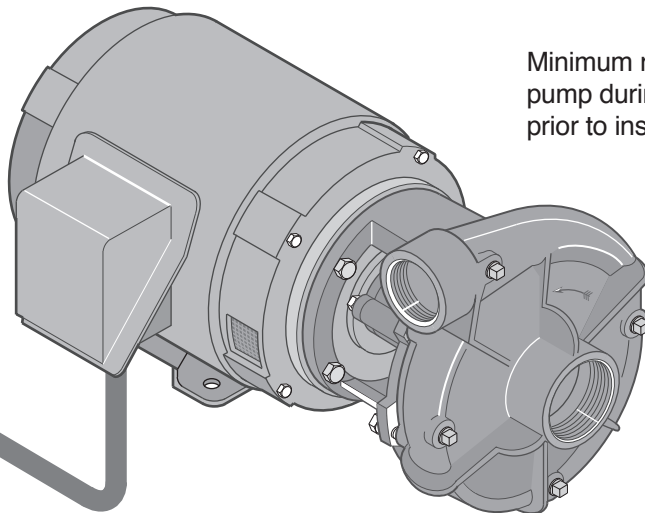

- Contactor**
- Lightning Arrestor**
- Loss of Prime Protection**
- Fusible Disconnect**
- Starter**

884 0494



## CHECK ROTATION:

Before pump is put into operation, rotational direction must be checked to assure proper performance of pump. Refer to illustration on Page 16.

**▲ WARNING** **Hazardous voltage. Can shock, burn, or cause death.** Disconnect power to pump before servicing.

Do not attempt any wiring changes without first disconnecting power to pump.

## PRIMING:

Pump priming is the displacement of air with water in the pump and suction piping. Pump **MUST BE** completely filled with water when operating.

Refer to Page 17 for instruction on the following conditions:

1. Suction lift with priming pump (water source below pump).
2. Suction lift with foot valve (water source below pump).
3. Flooded suction (water source above pump, or incoming water pressure is greater than atmospheric pressure).

**SPECIAL CASE - HYDRAULIC BALANCED PUMPS:** Hydraulic balanced pumps operate with a very low positive pressure across the stuffing box, permitting a much looser fit of the packing rings around the shaft sleeve to control the loss of water from the pump through the stuffing box. Because of the looser fit of the packing rings, air can be more easily drawn into the pump through the stuffing box when priming the pump with an air evacuation type primer.

A grease fitting, communicating through the side of the stuffing box to a lantern ring in the packing set, is provided to grease-seal the stuffing box to prevent air leakage during priming.

If pump cannot be primed due to air leakage through stuffing box, **DO NOT** tighten packing. Instead, pump grease into lantern ring until back pressure occurs forcing grease into the lantern ring, grease-sealing the stuffing box. After priming, when unit is put into operation, the grease will be flushed out through the packing by the water flowing outward through the stuffing box. Proceed with normal adjustment of the packing as described on Page 18. Note that the grease seal only is used for control of air leaking during priming, and that only the packing gland is used to control flow of water through the stuffing box during normal operation.

When necessary to replenish the grease supply use an NLGI no. 4 Water Pump Grease.

## STARTING:

**▲ WARNING** **Never run pump dry.** Running pump without water will overheat pump and damage internal parts. Always make sure pump is primed prior to start-up.

**NOTICE:** Refer to maintenance section if pump has packing for adjustment prior to start-up.

Prime pump by one of the above procedures. Turn on power to pump. Slowly open discharge valve until desired flow rate is achieved. Place the "Hand-Off-Auto" selector switch in the "Auto" position. The pump will be started automatically when the pilot device signals the motor starter.

## STOPPING:

Pump will stop automatically when the pilot device de-energizes the motor starter. Turn the "Hand-Off-Auto" selector switch to "Off" position if you want to stop the pump while it is running.



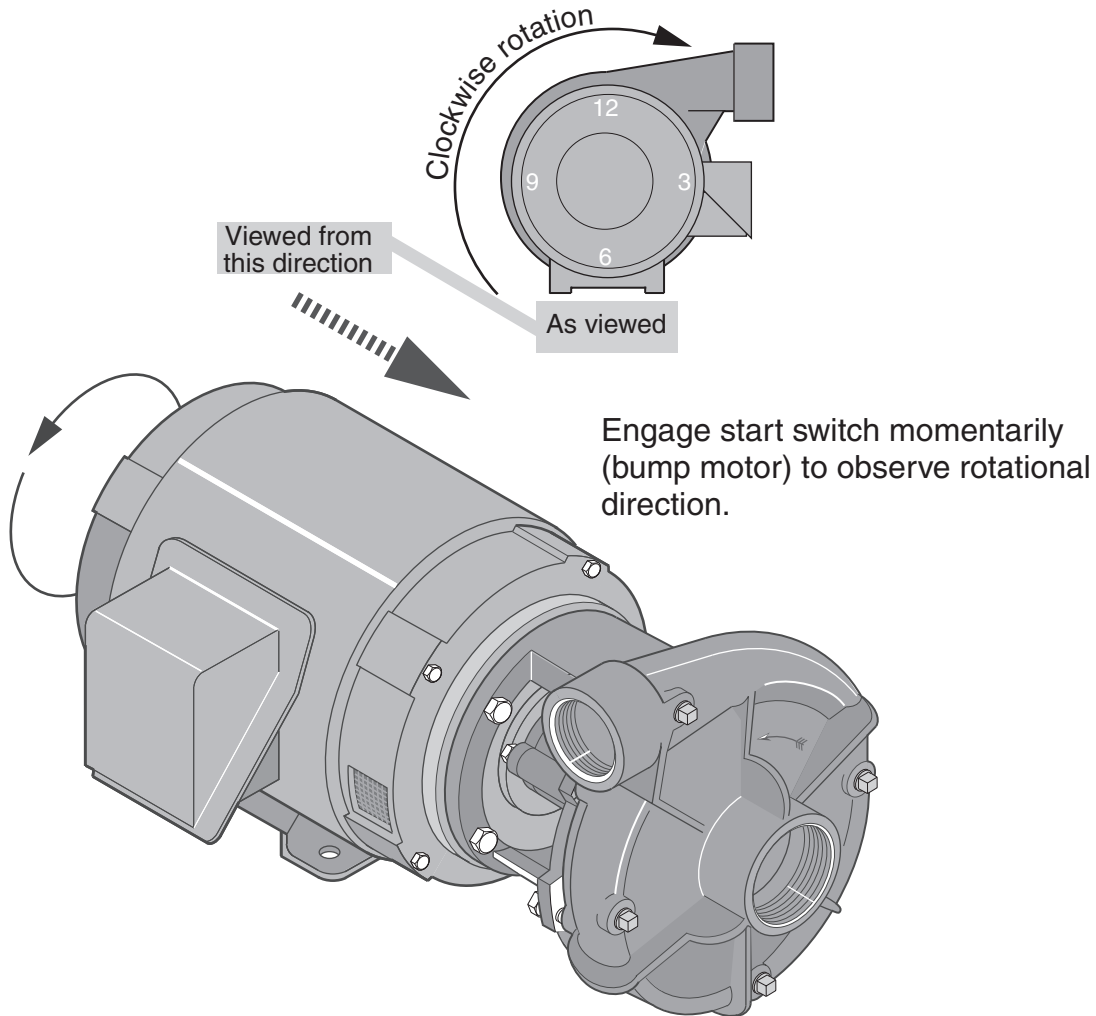

Direction of Pump Rotation is determined by viewing liquid end of pump from the **back** or **shaft side**, and **not** from looking into the impeller eye or front of volute case. A rotation direction arrow is cast into the pump body and shows correct rotation.

- Electric Motors:

**Single Phase:** Refer to wiring information on the motor plate to obtain proper rotation.

**Three Phase:** If pump runs backwards, reverse any two leads coming off incoming power (L1, L2, L3) until proper rotation is obtained. Reverse L1 and L2, or L2 and L3, or L1 and L3.

- Pump running backward - Centrifugal pumps will still pump liquids, however, GPM and head (discharge pressure) will be a fraction of the published performance.

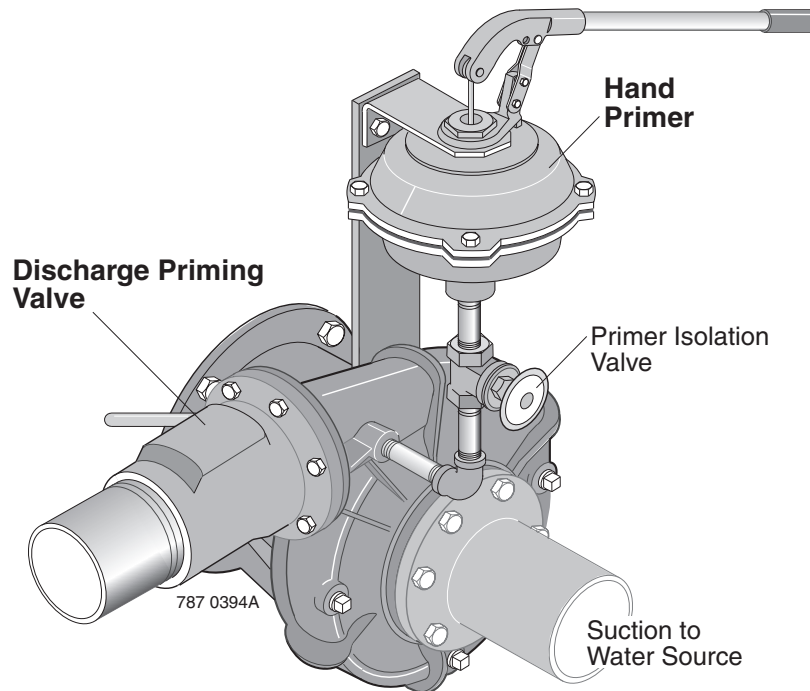

### Installations With Flooded Suction.

- Open air vent (or pipe plug) in the highest tapped opening in pump case.
- Open inlet isolation valve, allowing water to fill the pump completely and force all air out through vent.
- Rotate shaft slowly allowing any air trapped in impeller to escape.
- Close vent opening when water without air emerges.

### Installations With Suction Lift and Foot Valve.

- Close air tight valve on discharge.
- Remove pipe plug from highest opening on pump case.
- Completely fill pump and suction piping with water.
- Rotate shaft slowly allowing any air trapped in impeller to escape.
- When all air has been forced out of pump, replace pipe plug. Use pipe joint compound on plug threads and tighten as necessary to prevent leakage.

### Installations With Suction Lift and Priming Pump.

- Close air tight valve.
- Hand primer operation:
  1. Open hand primer isolation valve.
  2. Work handle of hand primer up and down to evacuate air from the suction line. (Refer to primer owner's manual for proper procedure).
  3. When water flows freely from primer, close hand primer isolation valve. (Pump case should now be filled with water).
- Immediately start pump.
- Slowly open butterfly valve (if used) until desired flow is achieved. (Discharge Priming Valve will open automatically).

**LUBRICATION:**

LIQUID END of pump requires **no** lubrication. Wear rings, packing rings, and models using a mechanical shaft seal, are lubricated by the liquid being pumped. Do not run dry!

**NOTE:** Grease fitting in packing area is for priming only. See *PRIMING* in start-up section for instruction.

MOTOR bearings are lubricated at the factory. Re-lubrication at intervals consistent with the amount of use will provide maximum bearing life. Refer to motor Instruction Manual for proper motor lubrication and maintenance instructions.

**PERFORMANCE CHECK:**

Periodically check the output of the pump. If performance is noticeably reduced, refer to Troubleshooting Chart.

**OBSERVATIONAL MAINTENANCE:**

When the pump and system operation have been stabilized, verify that pump unit is operating properly. Observe the following:

**VIBRATION:** All rotating machines can be expected to produce some vibration, however, excessive vibration can reduce the life of the unit. If the vibration seems excessive, discontinue operation, determine cause of the excessive vibration, and correct.

**NOISE:** When the unit is operating under load, listen closely for unusual sounds that might indicate that the unit is in distress. Determine the cause and correct.

**OPERATING TEMPERATURE:** During operation, heat is dissipated from the pump and the driver. After a short period of time, the surface of the pump bracket will be quite warm (as high as 150°F), which is normal. If the surface temperature of the pump bracket or driver is excessive, discontinue operation, determine cause of the excessive temperature rise, and correct. Bearings will run hotter for a brief run-in period after packing which is normal. However, worn bearings will cause excessive temperatures and need to be replaced. The pump unit is cooled by the water flowing through it, and will normally be at the temperature of the water being pumped.

**STUFFING BOX:** After a short period of operation, verify that the stuffing box area and gland are not

hot. If heating is detected, loosen the gland nuts evenly until water is just running out of stuffing box in a *DROPLET* form. Water must not be streaming or spraying out. Verify cool operation periodically. Adjust gland nuts *EVENLY* as necessary for lubrication and cooling of the packing. If packing has been tightened to the limit of the packing gland travel, additional packing is necessary.

**PACKING:** *Starting new pump.*

Before starting pump for the first time, loosen gland nuts and retighten finger tight. Proceed with pump start-up procedure. Allow packing to leak liberally for a few moments. Then tighten gland nuts one complete turn each until leakage is reduced to 40 to 60 drops per minute.

**REPACKING:**

Refer to Page 19.

**MECHANICAL SEAL:**

Adjustment or maintenance is normally not required. The seal is enclosed within the pump and is self adjusting. Seal is cooled and lubricated by the liquid being pumped. Refer to Pages 20 and 21 for removal and replacement. Do not run dry!

**PUMP PROTECTION-  
COLD WEATHER/  
WET WEATHER INSTALLATIONS:**

**SYSTEM DRAINS:** Provide drain valves to empty system, including pump case, to prevent freezing damage.

**SHELTER:** If possible, provide shelter for unit to protect from weather. Allow adequate space around pump unit for service. When effectively sheltered, a small amount of heat will keep temperature above freezing. Provide adequate ventilation for unit when running. For severe weather problems, where other shelter is not practical, a totally enclosed fan-cooled enclosure can be considered for electric motors.

**CONDENSATION:** When the temperature of metal parts is below dew point and the surrounding air is moist, water will condense on the metal surfaces and can cause corrosion damage. In severe situations, a space heater can be considered to warm the unit.

## REMOVAL

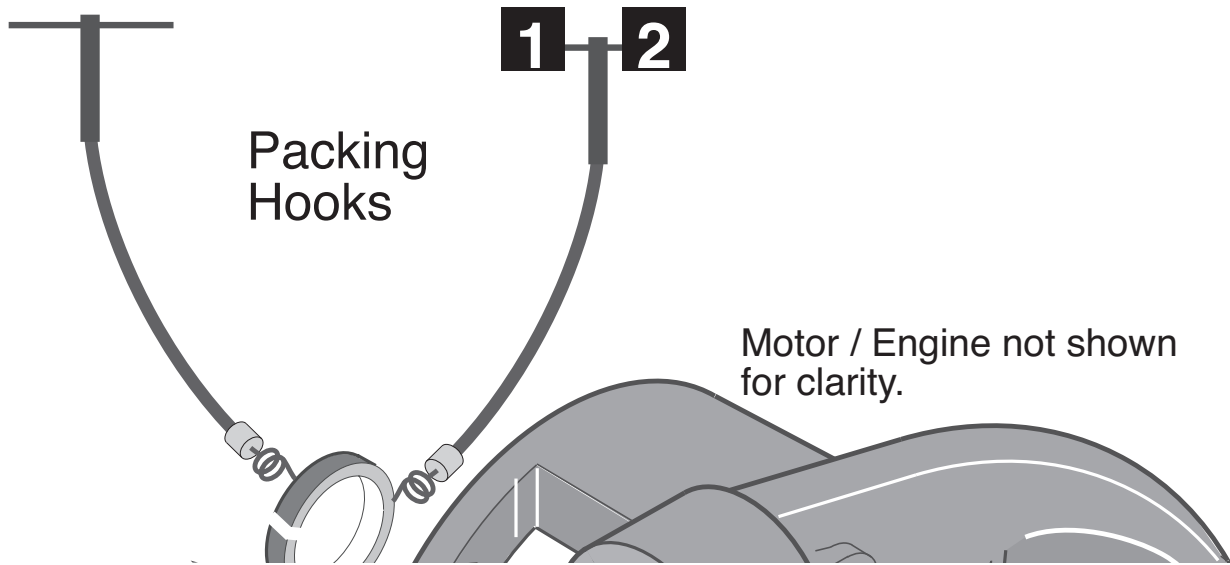

- Unfasten hardware holding Packing Gland in place and slide back on shaft to expose packing rings. A split Packing Gland is shown.
- Remove packing rings from Stuffing box using two commercially available Packing Hooks as shown.
- Slide Lantern Ring (if used) back to expose any remaining rings, including metallic. Remove them in the same manner.

## Installing New Rings

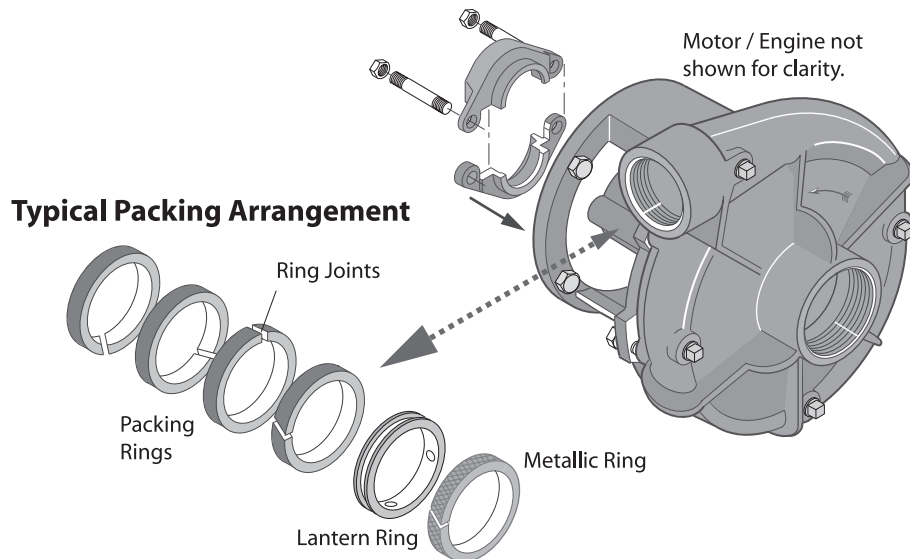

- Clean shaft sleeve and Packing Gland.
- Inspect shaft sleeve for wear, replace if needed.
- Install new packing rings in stuffing box by placing over shaft sleeve and pushing them in as far as they will go.
- Rotate ring joint 90 degrees when installing each ring as shown.
- Slide packing gland into position, then gently and evenly tighten nuts to force rings into place and seat (do not overtighten). Loosen nuts again to hand tight.
- Start primed pump and allow packing to leak liberally.
- Tighten gland nuts one complete turn each until leakage is reduced to 40 to 60 drops per minute.

MODELS B4ZPBH, B5ZPBH, B6ZPBHH. ALL OTHER MODELS TURN TO PAGE 22.

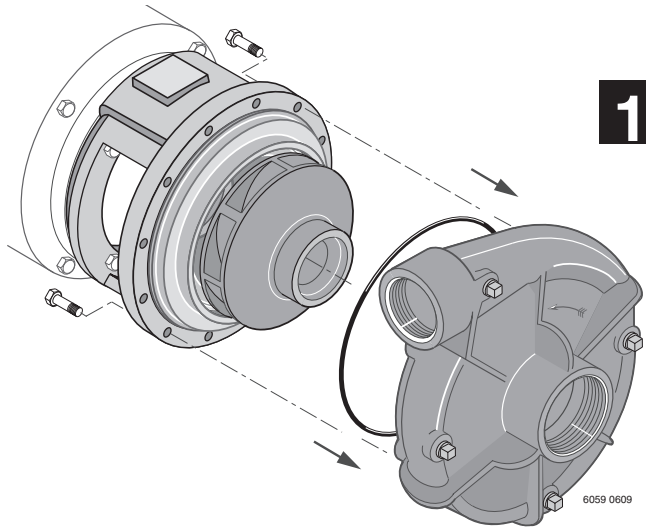

**1**

- Unfasten hardware holding volute to bracket.
- Remove volute to expose impeller.

**2**

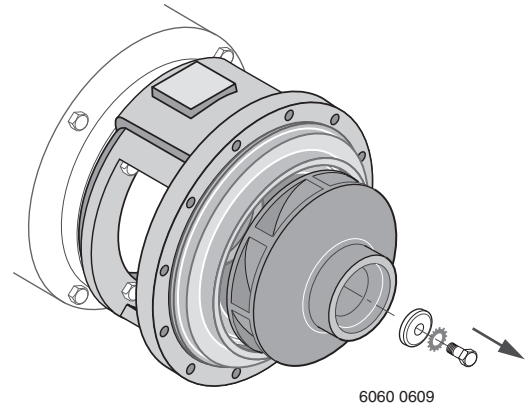

- Peel off old gasket or O-Ring and discard.
- Hold impeller stationary and remove impeller screw and associated hardware.

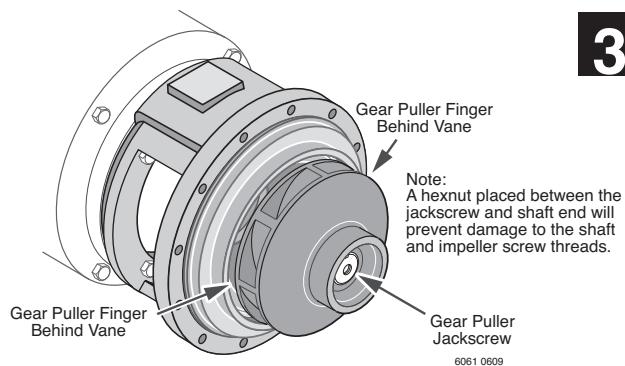

**3**

- Install a standard gear puller to shaft end and impeller, placing puller fingers behind impeller vanes as shown.

**4**

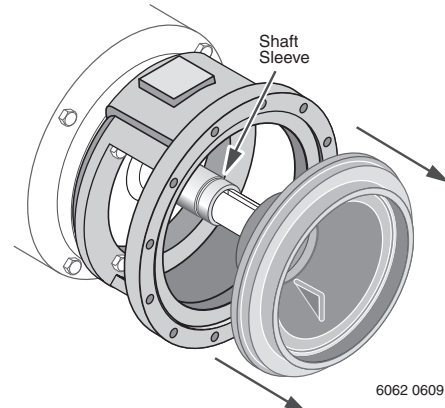

- Rotate gear puller jackscrew until impeller clears shaft. Remove shaft key.
- If a seal retaining ring is part of the assembly, remove it.
- Pull seal plate out of bracket. Mechanical shaft seal will come off with seal plate.

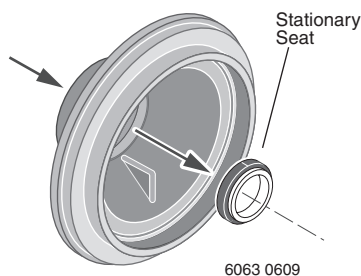

**5**

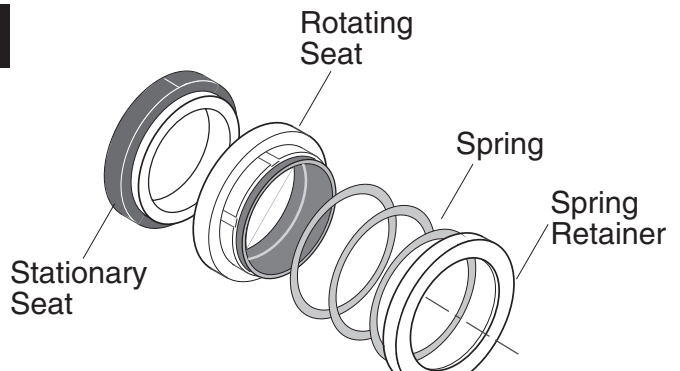

- Push stationary seal out of seal cavity from the back of seal plate.
- Clean seal cavity in seal plate thoroughly.

**Procedure and parts will vary slightly depending on pump style.**

MODELS B4ZPBH, B5ZPBH, B6ZPBHH. ALL OTHER MODELS TURN TO PAGE 22.

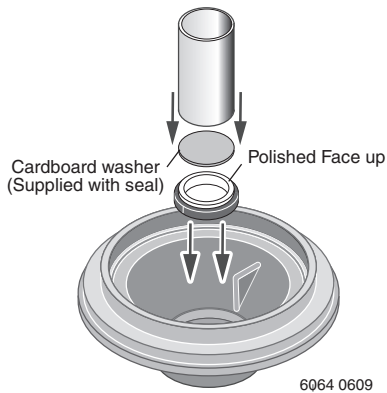

Do not scratch or chip polished ceramic face. Also . . .do not touch polished surface

1

2

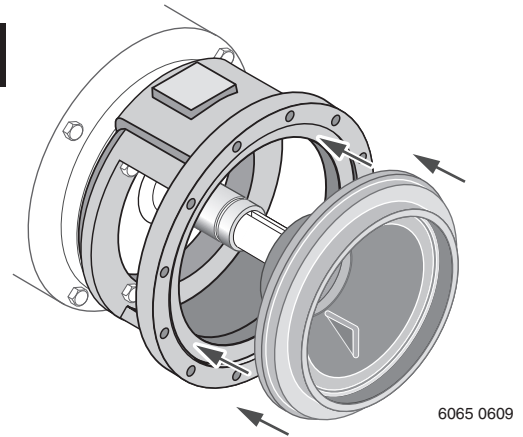

straight in using a piece of pipe or tubing.

- Place seal plate on a smooth, flat surface, pump side up.
- Apply a small amount of mineral oil to O-Ring on stationary seal and press into seal cavity. Cover ceramic face with cardboard washer and press

- Reinstall seal plate in bracket using extreme care not to scratch or chip ceramic face of seal with shaft.

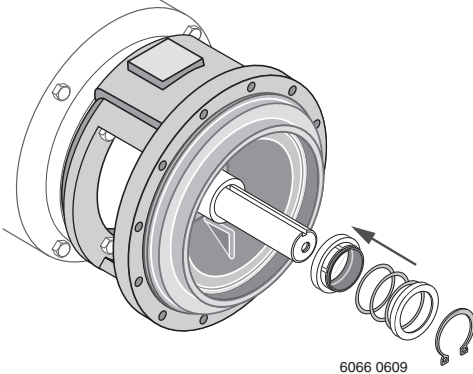

3

4

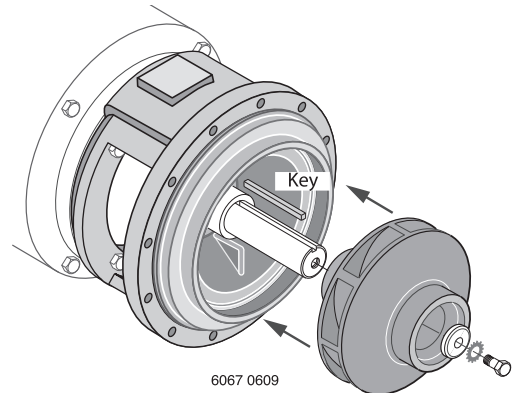

- Apply a small amount of mineral oil to inside diameter of rubber ring in rotating seat and outside of shaft sleeve. Slide rotating seat onto shaft, polished face first, until it is tight against ceramic face.
- Compress seal spring and install retaining ring in shaft sleeve groove (if used).
- Place impeller key in motor shaft keyway. Slide impeller on to shaft as far as possible.

- Clean threads thoroughly.
- Apply non-permanent thread adhesive to impeller capscrew and shaft threads.
- Install impeller washer, shakeproof lockwasher, and capscrew.

5

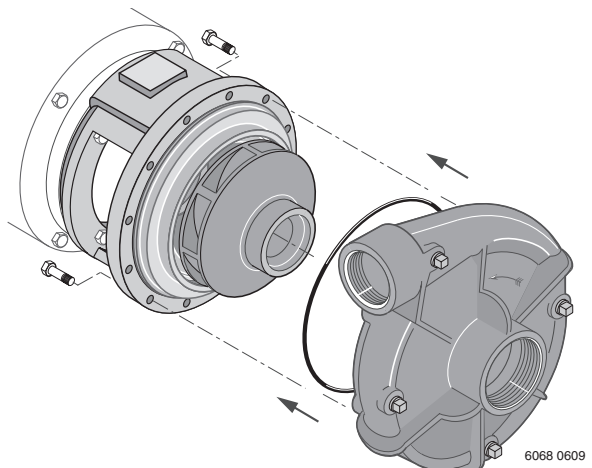

- Install gasket and volute on bracket. Use a new gasket or O-Ring when reassembling to prevent leakage ( a coat of grease on gasket will aid in future disassembly and maintenance).
- Apply anti-seizing compound to capscrews and tighten securely.

Procedure and parts will vary slightly depending on pump style.



REMOVAL

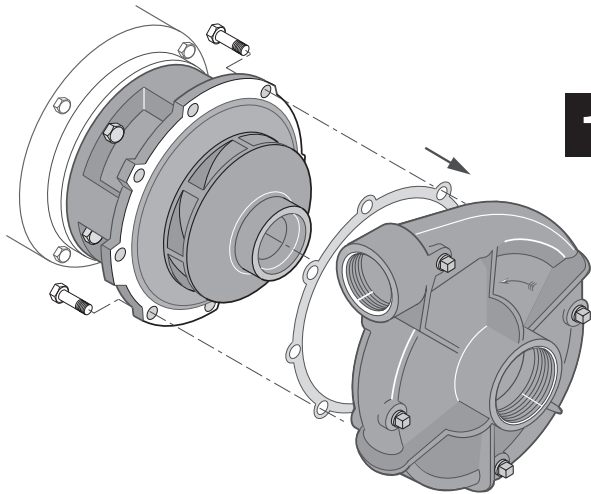

1

2

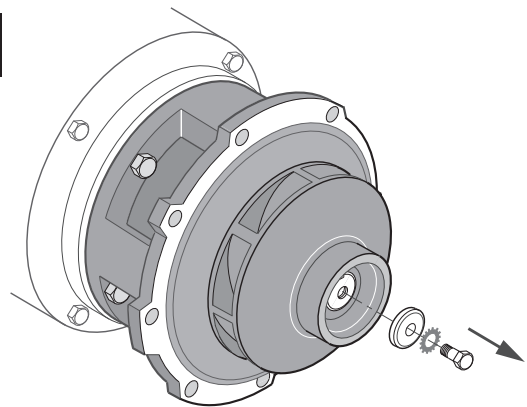

- Unfasten hardware holding volute to bracket.  
NOTE: For model B4EY, consult factory for special instructions.
- Remove volute to expose impeller.

- Peel off old gasket or O-Ring and discard.
- Hold impeller stationary and remove impeller screw and associated hardware.

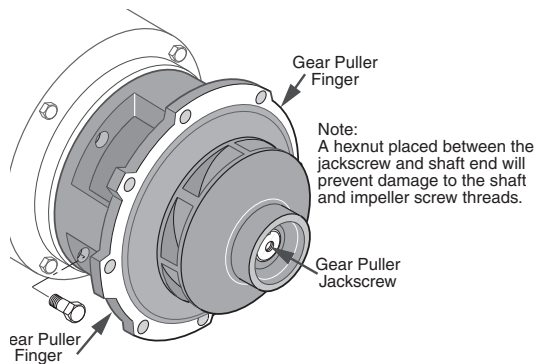

3

4

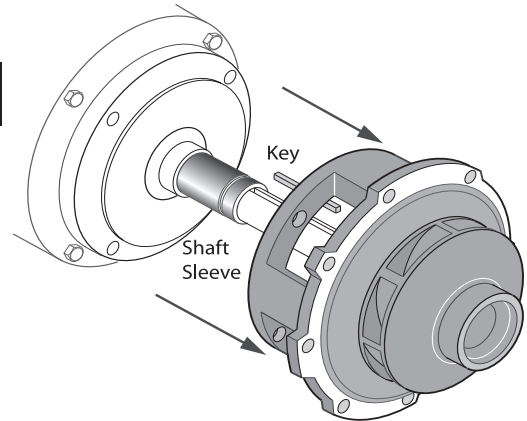

- Remove capscrews holding bracket to motor.
- Install a standard gear puller to shaft end and motor bracket placing puller fingers in the area shown.

- Rotate gear puller jackscrew until impeller clears shaft. Mechanical shaft seal will come off with motor bracket.
- If a seal retaining ring is part of the assembly, it will need to be replaced.

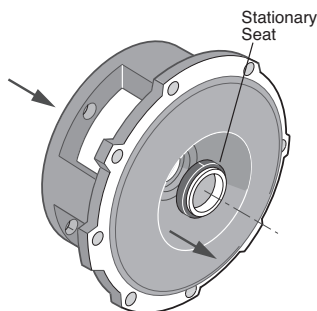

5

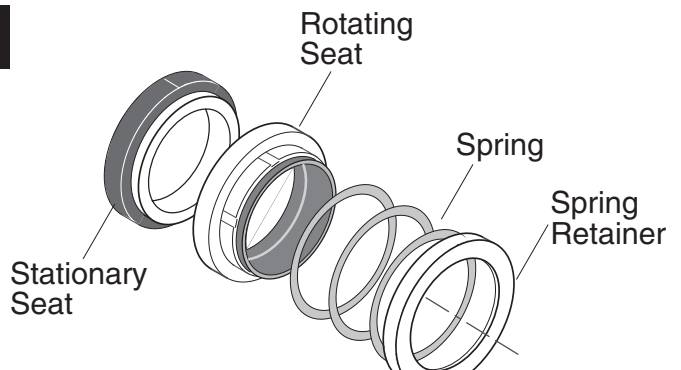

- Push stationary seal out of seal cavity from the back of bracket.
- Clean seal cavity in bracket thoroughly.

Procedure and parts will vary slightly depending on pump style.



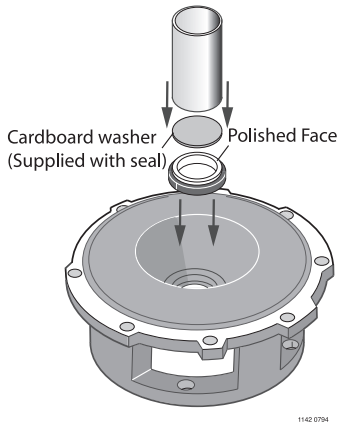

Do not scratch or chip polished ceramic face. Also . . .do not touch polished surface

- Place bracket on a smooth, flat surface, pump side up.
- Apply a small amount of mineral oil to O-Ring on stationary seal and press into seal cavity. Cover

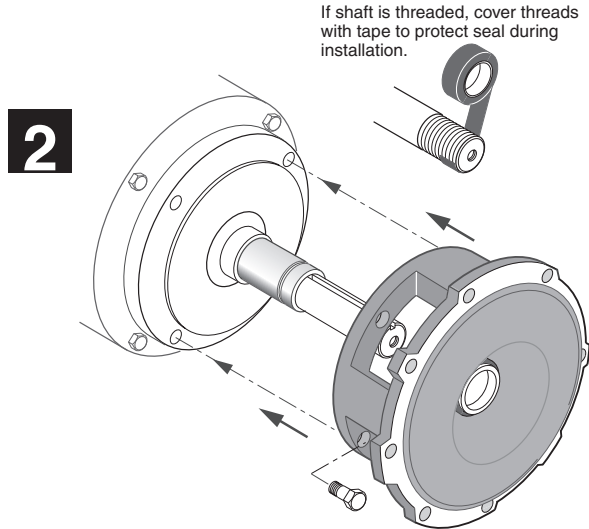

ceramic face with cardboard washer and press straight in using a piece of pipe or tubing.

- Reinstall bracket on motor using extreme care not to scratch or chip ceramic face of seal with shaft.

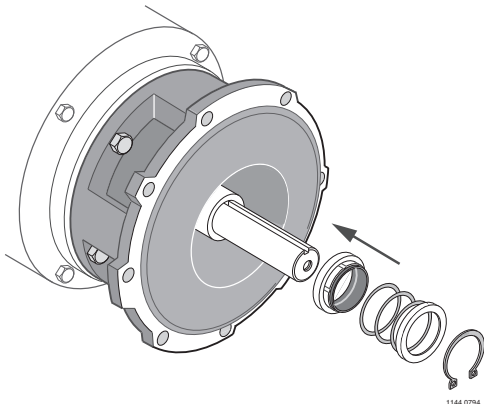

- Apply a small amount of mineral oil to inside diameter of rubber ring in rotating seat and outside of shaft sleeve. Slide rotating seat onto shaft, polished face first, until it is tight against ceramic face.
- Compress seal spring and install retaining ring in shaft sleeve groove (if used).
- Place impeller key in motor shaft keyway. Slide impeller on to shaft as far as possible.

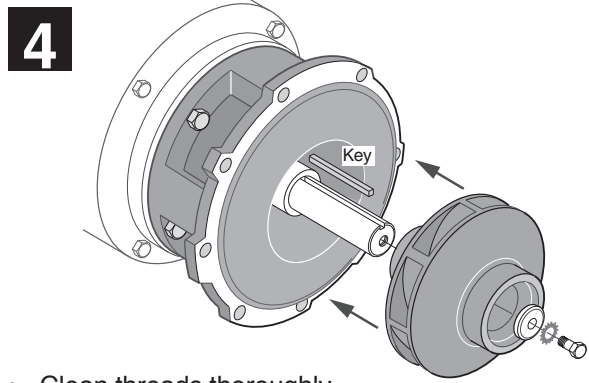

- Clean threads thoroughly.
- Apply non-permanent thread adhesive to impeller capscrew and shaft threads.
- Install impeller washer, shakeproof lockwasher, and capscrew.

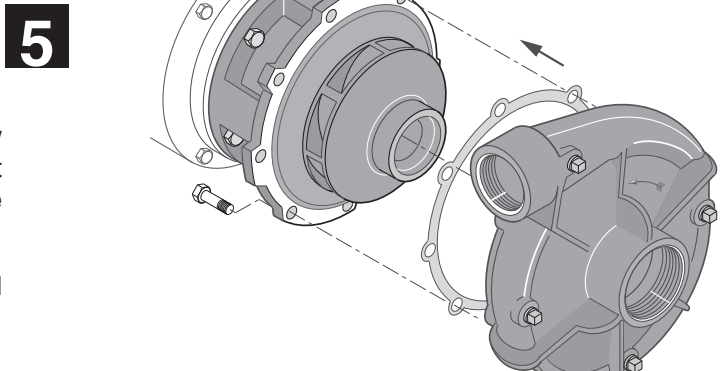

- Install gasket and volute on bracket. Use a new gasket or O-Ring when reassembling to prevent leakage ( a coat of grease on gasket will aid in future disassembly and maintenance).
- Apply anti-seizing compound to capscrews and tighten securely.

**Procedure and parts will vary slightly depending on pump style.**

## ORDERING REPLACEMENT PARTS:

Locate the Berkeley nameplate on the pump; plate is normally on the motor bracket. Information found on this plate is shown below. To be sure of receiving correct parts, provide all nameplate data when ordering. The **BM (Bill of Material)** number is most important. Write your nameplate information on the blank nameplate below for future reference as nameplates can become worn or lost.

Illustrations on the following page show typical components used in the assembly of motor drive centrifugal pumps. Both mechanical seal and packing styles are shown. Refer to these drawings when ordering any replacement parts.

### SAMPLE ONLY

MODEL B3TPMS	S.N. OR DATE G100894
IMPELLER DIA. 6-1/8"	B.M. B54598

788 0394

MODEL	S.N. OR DATE
IMPELLER DIA.	B.M.

Record your nameplate data here.

344 1093

## ELECTRIC MOTOR DRIVE - WITH REMOVABLE SEAL PLATE (B4ZPBH, B5ZPBH, B6ZPBHH)

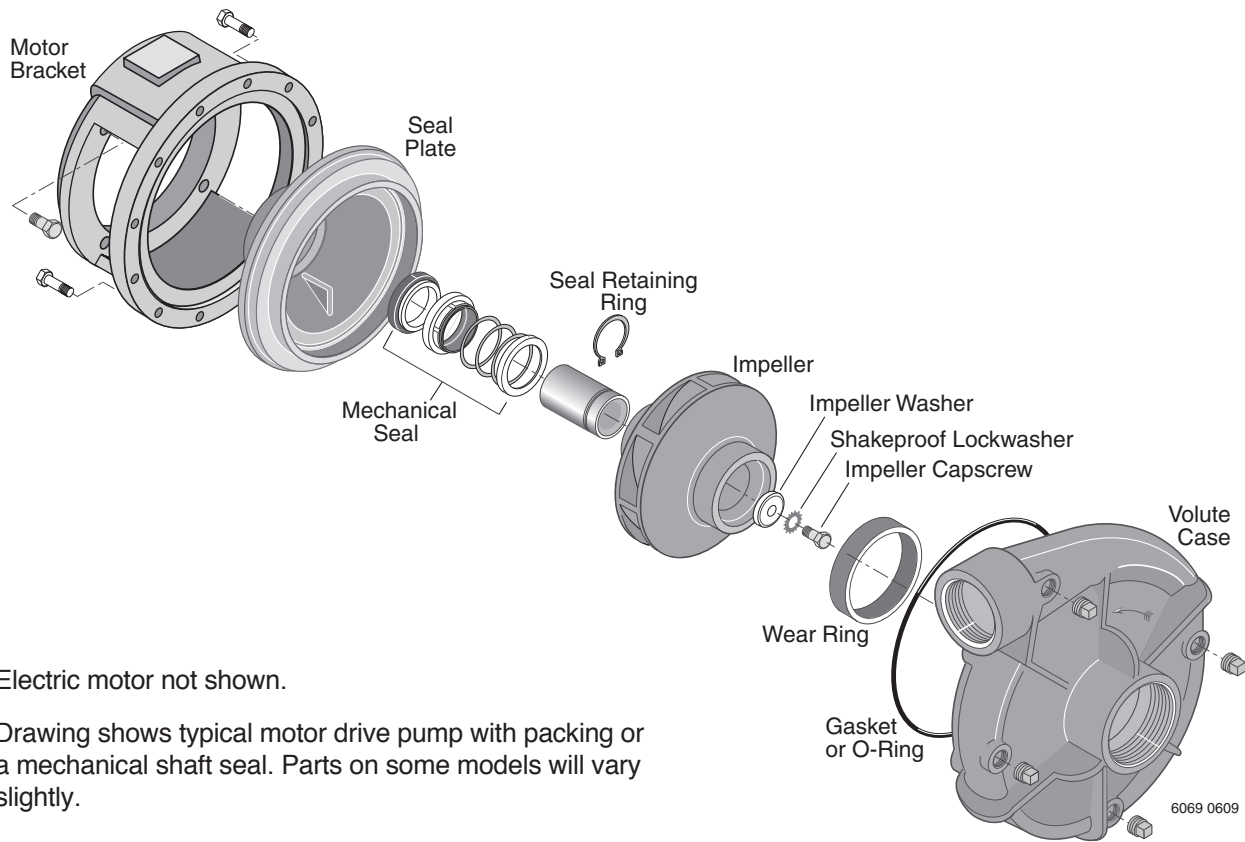

- Electric motor not shown.
- Drawing shows typical motor drive pump with packing or a mechanical shaft seal. Parts on some models will vary slightly.

### Packing

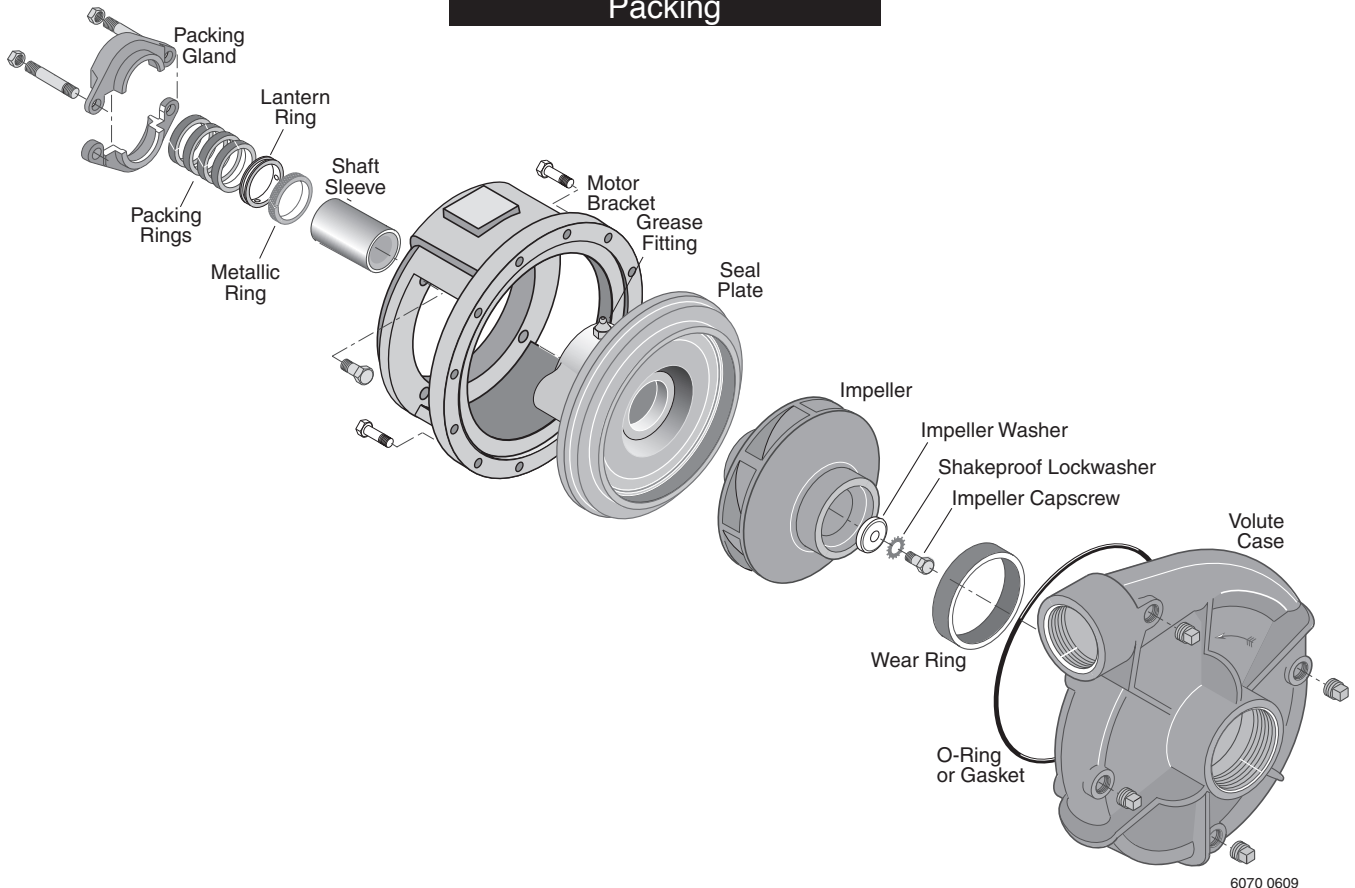

## ELECTRIC MOTOR DRIVE - WITH FIXED SEAL PLATE

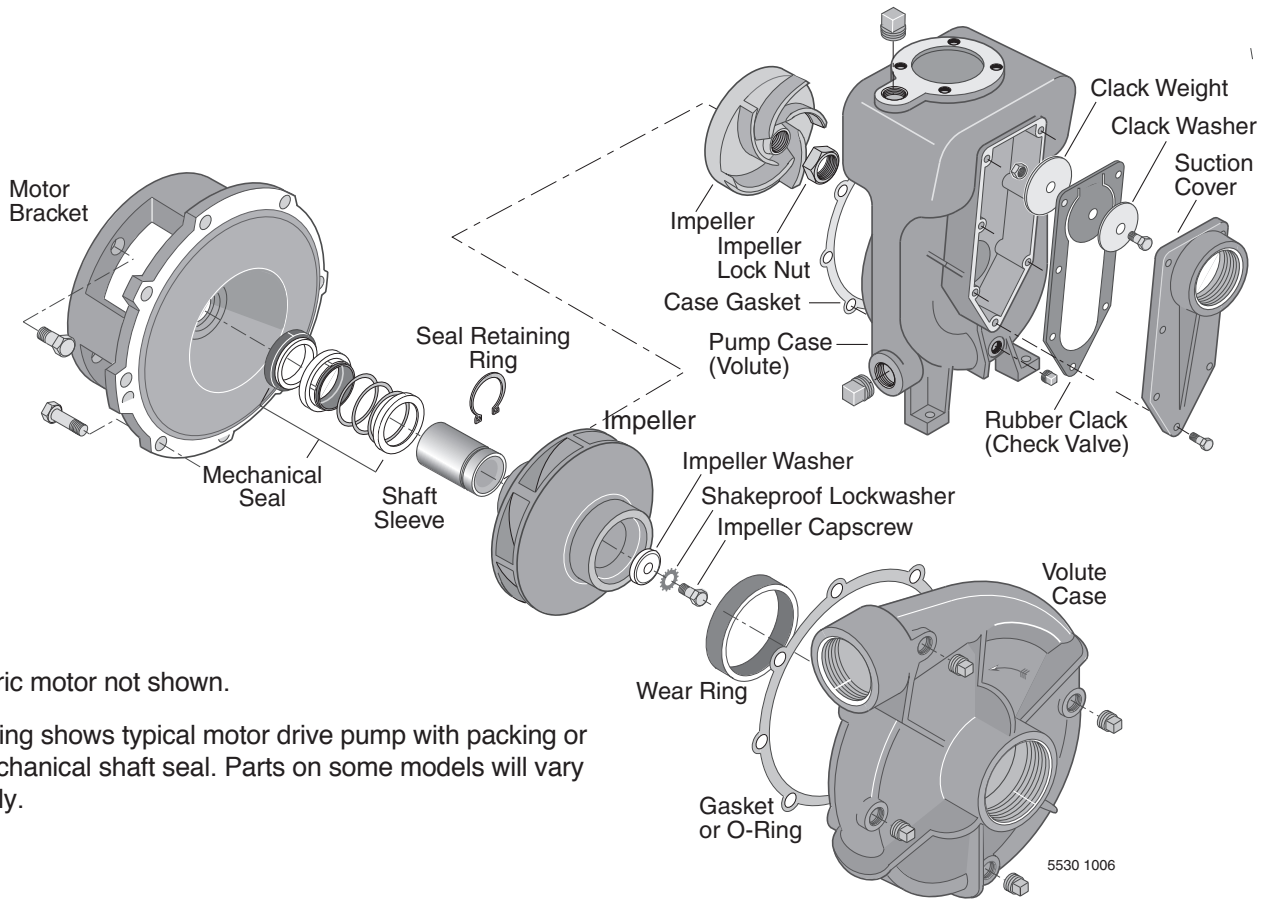

- Electric motor not shown.
- Drawing shows typical motor drive pump with packing or a mechanical shaft seal. Parts on some models will vary slightly.

### Packing

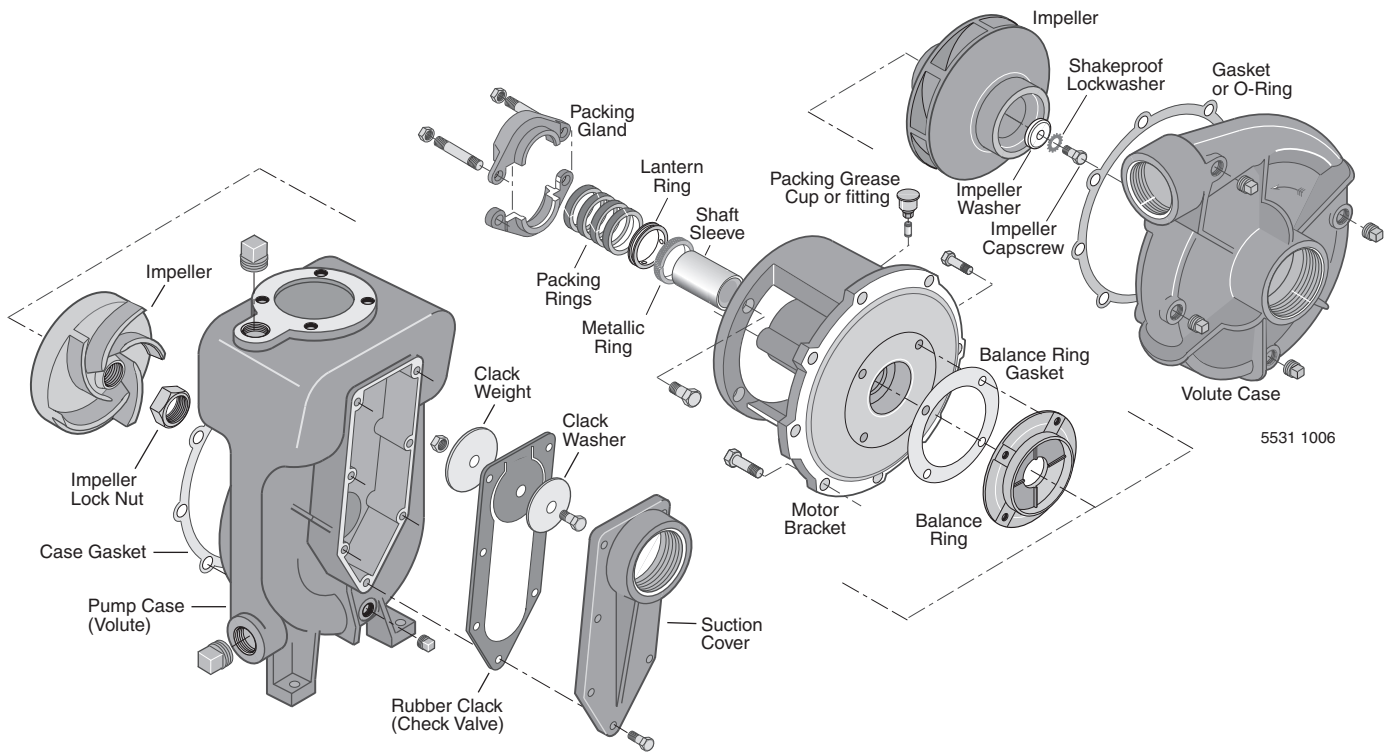

SYMPTOM	PROBABLE CAUSE																		
	GROUP I ELECTRICAL									GROUP II MECHANICAL					GROUP III SYSTEM				
	A	B	C	D	E	F	G	H	I	A	B	C	D	E	F	A	B	C	
Pump runs, but no water delivered										X		X					X	X	
Not enough water delivered			X	X					X	X	X		X				X	X	
Not enough pressure			X	X					X	X	X		X				X	X	
Excessive vibration									X	X	X			X				X	X
Abnormal noise										X	X	X		X	X			X	X
Pump stops	X	X	X	X	X	X	X	X											
Overheating		X	X	X					X		X		X	X	X				X

CAUSE	CORRECTIVE ACTION
<b>I. ELECTRICAL</b>	
A. No voltage in power system	Check phase-to-phase on line side of starter contactor. Check circuit breaker or fuses.
B. No voltage on one phase (Three Phase Units)	Check phase voltage on line side of starter contactor. Isolate open circuit (circuit breaker, fuse, broken connections, etc.)
C. Low voltage at motor	Running voltage across each leg of motor must be $\pm 10\%$ of nominal voltage shown on nameplate.
D. Motor leads improperly grouped for voltage	Refer to lead grouping diagram on motor nameplate.
E. Control failure	Check control device, starter contactor, H-O-A selector switch, etc., for malfunction.
F. Thermal overload switch open	Check phase-to-phase on line side of starter contactor.
G. Installation failure	Check motor or windings to ground with megohmmeter.
H. Open windings	Check leg-to-leg with ohmmeter.
I. Frequency variation	Check frequency of power system. Must be less than 5% variation from motor nameplate rating.
<b>II. MECHANICAL</b>	
A. Flow through pump completely or partially obstructed	Locate and remove obstruction. Refer to Repair Instructions for disassembly.
B. Wrong direction of rotation	Reverse rotation of three phase motor by interchanging any two leads. See manufacturer's Instructions for reversing single phase motor.
C. Pump not primed	Reprime. Inspect suction system for air leaks.
D. Internal leakage	Check impeller for wear of controlled clearances (See Repair Instructions).
E. Loose parts	Inspect. Repair.
F. Stuffing box not properly adjusted	Adjust gland.
<b>III. SYSTEM</b>	
A. Pressure required by system at design flow rate exceeds pressure rating of pump	Compare pump pressure and flow rate against pump characteristic curve. Check for closed or partially closed valve in discharge piping system. Reduce system pressure requirement. Increase pressure capability of pump.
B. Obstruction in suction piping	Locate and remove obstruction.
C. Pressure rating of pump exceeds pressure requirement of system at design flow rate	Compare pump pressure and flow rate against pump characteristic curve. Inspect discharge piping system for breaks, leaks, open by-pass valves, etc. If necessary, reduce flow rate by partially closing discharge valve.

## Limited Warranty

BERKELEY warrants to the original consumer purchaser ("Purchaser" or "You") of the products listed below, that they will be free from defects in material and workmanship for the Warranty Period shown below.

Product	Warranty Period
<b>Water Systems:</b>	
Water Systems Products — jet pumps, small centrifugal pumps, submersible pumps and related accessories	<i>whichever occurs first:</i> 12 months from date of original installation, or 18 months from date of manufacture
Pro-Source™ Composite Tanks	5 years from date of original installation
Pro-Source™ Steel Pressure Tanks	5 years from date of original installation
Pro-Source™ Epoxy-Lined Tanks	3 years from date of original installation
Sump/Sewage/Effluent Products	12 months from date of original installation, or 18 months from date of manufacture
<b>Agricultural/Commercial:</b>	
Centrifugals – close-coupled motor drive, frame mount, SAE mount, engine drive, VMS, SSCX, SSHM, solids handling, submersible solids handling	12 months from date of original installation, or 24 months from date of manufacture
Submersible Turbines, 6" diameter and larger	12 months from date of original installation, or 24 months from date of manufacture

Our limited warranty will not apply to any product that, in our sole judgement, has been subject to negligence, misapplication, improper installation, or improper maintenance. Without limiting the foregoing, operating a three phase motor with single phase power through a phase converter will void the warranty. Note also that three phase motors must be protected by three-leg, ambient compensated, extra-quick trip overload relays of the recommended size or the warranty is void.

Your only remedy, and BERKELEY's only duty, is that BERKELEY repair or replace defective products (at BERKELEY's choice). You must pay all labor and shipping charges associated with this warranty and must request warranty service through the installing dealer as soon as a problem is discovered. No request for service will be accepted if received after the Warranty Period has expired. This warranty is not transferable.

BERKELEY SHALL NOT BE LIABLE FOR ANY CONSEQUENTIAL, INCIDENTAL, OR CONTINGENT DAMAGES WHATSOEVER. THE FOREGOING LIMITED WARRANTIES ARE EXCLUSIVE AND IN LIEU OF ALL OTHER EXPRESS AND IMPLIED WARRANTIES, INCLUDING BUT NOT LIMITED TO IMPLIED WARRANTIES OF MERCHANTABILITY AND FITNESS FOR A PARTICULAR PURPOSE. THE FOREGOING LIMITED WARRANTIES SHALL NOT EXTEND BEYOND THE DURATION PROVIDED HEREIN.

Some states do not allow the exclusion or limitation of incidental or consequential damages or limitations on the duration of an implied warranty, so the above limitations or exclusions may not apply to You. This warranty gives You specific legal rights and You may also have other rights which vary from state to state.

This Limited Warranty is effective June 1, 2011 and replaces all undated warranties and warranties dated before June 1, 2011.

**In the U.S.: BERKELEY, 293 Wright St., Delavan, WI 53115**

**In Canada: 269 Trillium Dr., Kitchener, Ontario N2G 4W5**