



MODEL 6TS 6"

SUBMERSIBLE TURBINES



INSTALLATION AND OPERATION MANUAL

TABLE OF CONTENTS

Safety Information 3

Installation 4-8

Service 9-12

Parts List 13

Troubleshooting 14

Warranty 15

SAFETY INFORMATION

IMPORTANT SAFETY INSTRUCTIONS

SAVE THESE INSTRUCTIONS: For optimal performance and operation, read these instructions carefully before installing your new pump. This manual provides valuable guidance and instructions that should be followed to perform installation, operation and maintenance procedures for this product. It should be kept near the installation for immediate reference. Record nameplate data from your new pump on the blank template located in "Maintenance" on Page 7 for future reference.

⚠ This is the safety alert symbol. When you see this symbol on your pump or in this manual, look for one of the following signal words and be alert to the potential for personal injury.

⚠ DANGER warns about hazards that will cause serious personal injury, death or major property damage if ignored.

⚠ WARNING warns about hazards that can cause serious personal injury, death or major property damage if ignored.

⚠ CAUTION warns about hazards that will or can cause minor personal injury or property damage if ignored.

NOTICE indicates special instructions which are important but not related to hazards.

The hazards stated in this manual are not all-inclusive. To minimize the risk of hazard, it is strongly recommended that installation, operation and maintenance be performed by a qualified professional in accordance with local codes and standards for safe operation.

CALIFORNIA PROPOSITION 65 WARNING

⚠ WARNING This product and related accessories contain chemicals known to the State of California to cause cancer, birth defects or other reproductive harm.

ELECTRICAL SAFETY

⚠ WARNING Risk of electric shock. Can shock, burn or kill. All wiring should be done by a qualified electrician.

- ◆ Wire motor for correct voltage. See "Installation" section (refer to page 5) of this manual and motor nameplate.
- ◆ Ground motor before connecting to power supply.
- ◆ Follow wiring instructions in this manual when connecting motor to power lines.
- ◆ A complete power disconnect switch must be incorporated in the fixed wiring.
- ◆ Install, ground, wire and maintain your pump in compliance with all applicable national and local codes and ordinances. Consult your local building inspector for code information.

GENERAL SAFETY

⚠ WARNING Risk of explosion. The pump body may explode if used to boost pressure above the pressures noted on Page 3. Do not use this pump with inlet pressure greater than 70 psi (483 kPa) or less than 3 psi (20.7 kPa). If not already in the piping system, install a pressure relief valve in the pump discharge line capable of passing the full pump flow at maximum rated pressure. If local code requires installation of a pressure relief valve capable of handling the full pump flow at a pressure less than 100 psi (689 kPa), follow the code requirements.

⚠ WARNING Risk of fire or explosion. To avoid risk of fire and explosion, pump water only with this pump. Do not pump salt water, flammable liquids or chemicals. Do not use the pump near gas pilot lights or where chemical or gas fumes are present. Use of an electric pump with liquids other than water or in an atmosphere containing chemical or gas fumes may ignite those liquids or gases and cause injury or death due to an explosion and/or fire. Pump approved liquids only with this pump.

⚠ CAUTION Risk of burns. If water is trapped in the pump during operation it may turn to steam. Trapped steam may cause an explosion resulting in injury or property damage. Never run the pump with the outlet closed or obstructed.

⚠ CAUTION Risk of freezing. Do not allow pump, piping, or any other system component containing water to freeze. Freezing may damage system, leading to injury or flooding. Allowing pump or system components to freeze will void the warranty.

NOTICE only service agent or qualified person should replace power cord to avoid injury.

Periodically inspect pump and system components.

Wear safety glasses at all times when working on pumps.

Keep work area clean, uncluttered and properly lighted; store properly all unused tools and equipment.

ORDERING REPLACEMENT PARTS

Locate the Pentair Sta-Rite* nameplate on pump. This plate is normally on the pump case or bracket (seal plate). To ensure receipt of correct parts, provide all nameplate data when ordering. Catalog number is most important to reference. Write the nameplate information below, as nameplates can become worn or lost.

Model: _____

S.N. or Date: _____

Impeller Dia: _____

Catalog No: _____

INSTALLATION

GENERAL CONSIDERATIONS

Before installing your submersible turbine pump, review the following checklist.

- ◆ Be sure the well is clear of sand and abrasive material before installing pump. Abrasive materials in the water cause component wear and reduce pump capacity and discharge pressure. Never use the pump to develop or clean the well. Permanent pump damage can result within the first few hours of operation.
- ◆ If the well casing is suspected of being crooked, check it with a gauge of identical length and diameter as the pump and motor with two lengths of pipe attached. Serious damage can result if the pump becomes lodged in a crooked casing.
- ◆ Be sure the well can supply a high-capacity turbine pump. The well should be deep enough to cover the pump unit with water, even at extreme pumping rates. Typically, the pump should be submerged 10 to 20 feet below the lowest water level and at least 5 feet above the bottom of the well.
- ◆ Air entrained in the water reduces performance and will damage the pump.
- ◆ Your pump is designed to provide maximum efficiency under specific capacity and head conditions. Do not operate it beyond specified limits.
- ◆ System controls and pump must match. Do not interchange controls with other models. Serious damage can result to the unit if pump and controls do not match.
- ◆ Average number of starts per day will influence motor and control component life (starters, relays, capacitors, etc). Select pump size, tank size and control components for lowest practical number of starts per day. Excessive cycling accelerates bearing, spline, and pump wear and control contact erosion.

SPECIFICATIONS

AVERAGE NUMBER OF STARTS PER HOUR		
HP RATING	SINGLE PHASE	THREE PHASE
1 to 50	15	15

Table I: Frequency of Starts

PIPE SIZE (IN)	WEIGHT PER FOOT (LBS)	
	FULL	EMPTY
2-1/2	7.9	5.8
3	10.8	7.6
4	16.3	10.8
5	23.3	14.62
6	31.5	18.97

Table II: Weight of Pipe (Column)

AWG SIZE	3-PHASE		1-PHASE	
	NOM. DIA.	WEIGHT	NOM. DIA.	WEIGHT
12-3	.500	140	.487	130
10-3	.545	186	.517	161
8-3	.771	328	.750	293
6-3	.965	525	.826	400
4-3	1.071	717		
2-3	1.243	1066		

Table III: Weight of Cable per 1000 ft. (lbs.)

AWG WIRE SIZE	RESIST (OHMS/FT)
14	.0050
12	.0032
10	.0020
8	.0013
6	.0008
4	.0005
2	.0003

Table IV: Cable Wire Resistance

PREINSTALLATION PROCEDURES AND CHECKS

ELECTRICAL SPLICES AND CONNECTIONS

Spllices must be waterproof. Make a strong mechanical bond between the motor leads and the cable to avoid high resistance at the connection. A poor mechanical connection, or a poorly wrapped splice, can cause motor problems and motor failure.

Before connecting the motor to the cable, perform a ground check to assure that the motor has not been damaged. Attach one end of an ohmmeter lead to any of the three motor leads and the other ohmmeter lead to the pump intake bracket. A new motor must have a resistance of 2 megohms or greater. If not, contact your dealer. Repeat for all three leads.

INSTALLATION

CASING SIZE	GPM											
	20	40	60	80	100	120	140	160	180	200	220	240
6" ID	1.2	2.3	3.5	4.6	5.8	7.0	8.0	9.3	10.4	11.6	12.7	13.9
8" ID	-	0.5	0.7	0.9	1.2	1.4	1.6	1.9	2.1	2.3	2.6	2.8
10" ID	-	-	0.3	0.5	0.6	0.7	0.8	0.9	1.0	1.1	1.3	1.4

FPS

FORMULA TO FIND FLOW RATE:

$$FPS = \frac{GPM \times .409}{D1^2 - D2^2}$$

D1 = Casing inside diameter

D2 = Motor outside diameter

NOTICE: If flow rate past motor is expected to be less than rate shown in table, install a shroud around motor to force cooling flow past shell. To minimize erosion to shell if flow rate is expected to be more than 10 FPS (especially if sand is present), reduce flow through pump to reduce flow past shell.

Table V: Cooling Flow Rates Past Submersible Motors

Prepare the cable and make the mechanical connections (Figure 1A) and splices as follows:

- Cut motor leads and corresponding cable ends at 3-inch spacings to stagger connections for a smooth splice.
- Cut connecting cable to match the motor leads.

NOTICE: Match color coded wires, red to red, black to black, and white to white.
- When using a butt connector, expose bare wire for about 1/2". When using stranded wire, expose about 1" of wire.

NOTICE: Butt connectors may be used with solid wires through 8 AWG, or stranded wires through 10 AWG.
- Clean exposed ends of wire thoroughly with emery cloth or sandpaper to assure good electrical connections.
- BUTT CONNECTORS (Figure 1A): Insert wires into connector until insulation butts up against connector. Crimp connector to wires with a pair of crimping pliers. Pull on cable to make sure the connection is solid and tight.
- SOLDERED CONNECTIONS (Figure 1A):

NOTICE: Do not use acid core solder or corrosive solder paste.

- Straighten individual cable strands and spread apart slightly.
- Clean each strand and push strands of cable into matching (color-coded) open strands of the motor leads.
- Wrap entire length of joint with fine copper wire until strands are compressed.
- Apply heat and solder. Solder will follow the heat; make sure solder flows throughout the joint. Pull firmly on cable to test joint.

- Repeat Step 5 for each lead.

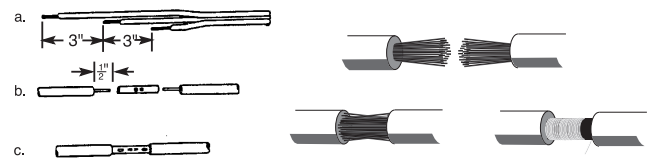

Figure 1A: Cable Splicing: Solid Wire, Stranded Wire

- Taping splice (Figure 1B):

CAUTION Because friction tape is not water resistant, never use friction tape on a water-tight splice. Use Scotch Number 33, or equivalent.

- Clean joints and adjoining cable/wire insulation of all grease and dirt, and build up joint area with tape until it matches diameter of cable.
- Starting 1-1/2" back from the joint, firmly apply one layer of tape, overlapping about half the previous lap and continuing approximately 1-1/2" beyond joint. Cut tape evenly and press both ends firmly against cable.

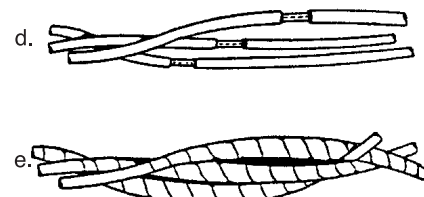

Figure 1B: Stagger Splices and Tape

- Apply two additional layers of tape, as described in Step 7B, beginning and ending 1-1/2" beyond the previous starting/ending points.

INSTALLATION

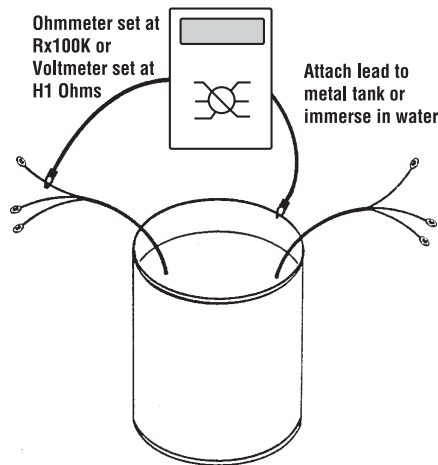

Figure 1C: Splice and Cable Continuity

SPLICE AND CABLE CONTINUITY TEST

Before installing pump check cable and splices as follows (see Figure 1C):

1. Submerge cable and splice in steel barrel filled with water. Make sure both ends of cable are out of water.
2. Clip one ohmmeter lead to barrel. Test each lead in cable successively by connecting the other ohmmeter lead to the three cable leads, one after the other.
3. If resistance reading goes to zero on any cable lead, a leak to ground is present. Pull splice out of water. If meter reading changes to "infinity" (no reading) the leak is in the splice.
4. If leak is not in splice, slowly pull cable out of water until reading changes to "infinity". Reading will change to "infinity" when leak comes out of water.
5. Repair cable by splicing as explained under "Electrical Splices and Connections".

ROTATION CHECK (3-PHASE ONLY)

After satisfactorily completing continuity test, connect cable to pump controller. Check 3-phase motors for correct rotation. If necessary, reverse any two cable leads at the controller and recheck rotation. Permanently mark and match to control box terminals for future reference. Connect cable to motor controller and then wire controller to disconnect switch. Connect temporary jumper wire between proper terminals in controller to temporarily energize magnetic coil.

Momentarily engage disconnect switch and note direction of rotation. The shaft should rotate counterclockwise when viewed from the top or shaft end of the motor. If rotation is incorrect, reverse any two wires; mark wires to correspond with the controller terminal numbers.

NOTICE: Pump is water lubricated. Do not operate the pump for more than 5 seconds while it is out of water.

GENERAL INSTALLATION

After completing all connections and tests so far, connect a 5-foot length of pipe to pump.

Lower pump into well with pipe clamps attached to the 5-foot pipe. Attach a standard length of pipe to 5-foot length and lower pump CAREFULLY into well.

NOTICE: Do not use a pipe longer than 5 feet for the first connection. Hoisting pump upright with a long length of pipe can cause pump misalignment from excessive leverage.

CAUTION Use extreme care when lowering pump and cable to avoid damage to cable insulation.

Anchor power cable to pipe every 20 feet with adjustable steel band clamps. Protect insulation from clamps with pieces of split rubber hose inserted between clamps and cable. Attach cable to pipe halfway between clamps with waterproof tape (Scotch No. 33 or equivalent).

SUBMERGENCE

Be sure the pump is always submerged, even at extreme pumping rates. Install pump at least 10 to 20 feet below the lowest "drawdown" water level and at least 5 feet above bottom of well.

CHECK VALVES

Pump back spin and hydraulic shock can cause severe damage to the pump and motor. Install at least one check valve in the discharge pipe (riser pipe) to help prevent this.

Install the first check valve in the pump discharge or in the discharge pipe it self, not more than 25' above the pump. Install another check valve not more than 200 feet above the first one. Repeat, all the way up the riser pipe. The last check valve on the

INSTALLATION

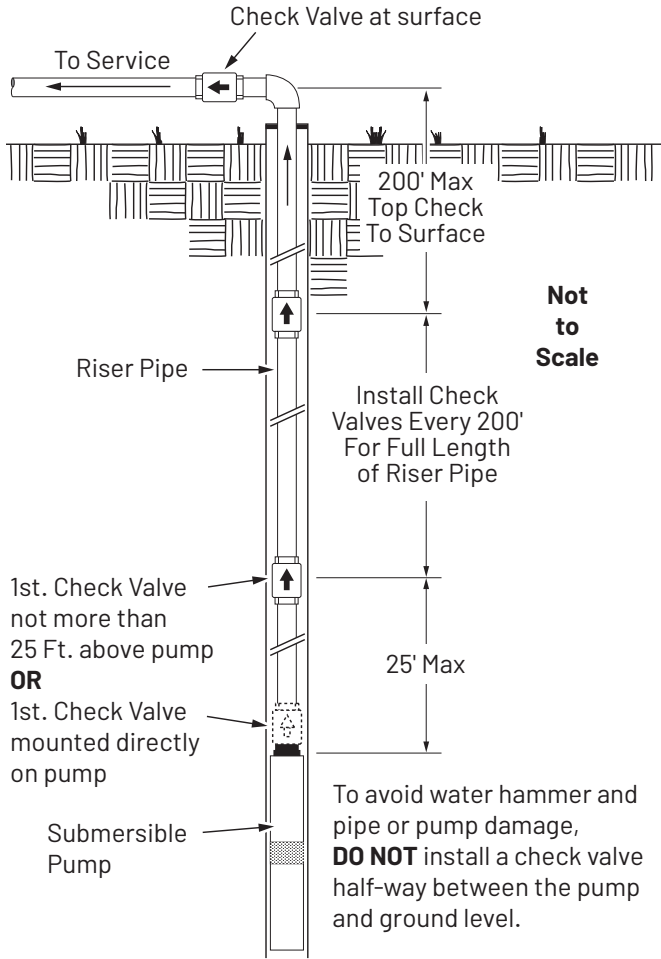

Figure 2: Check Valve Location

riser pipe should be not more than 200' below the surface. Finally, install a check valve near the well head in the horizontal pipe at the surface (see Figure 2).

NOTICE: To avoid water hammer and pipe breakage, **do not** put a check valve exactly half-way up the riser pipe (that is, with equal distance down to the pump and up to the surface), especially if it is the only check valve in the riser pipe after the pump discharge check. The 'equal distance' in both legs of the pipe can allow resonations from water hammer which can blow the pump off the riser pipe.

WELL AND PUMP TEST

Check and record static water level of well before starting tests. Before making final piping connections, test flow rate, capacity, and condition of well.

NOTICE: Do not operate pump with discharge valve closed. Operate pump only within pressure and flow limits of operating range established by performance curve.

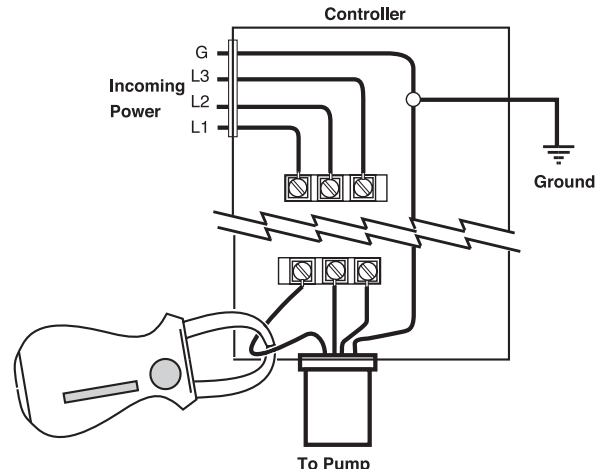

Figure 4: Load Current Test

NOTICE: If sand is present in discharge, allow pump to run with discharge completely open until water is clear. If loud rattling noises develop, pump is probably cavitating. Gradually close discharge valve until rattling stops.

INSTALLATION - ELECTRICAL TESTS

⚠ WARNING Risk of high voltage electrical shock when testing. Can stun, burn, or kill.

Only qualified electricians should perform these tests. When testing, use all normal precautions for the voltages involved.

ELECTRICAL TEST OF MOTOR, CABLE, CONNECTIONS

The cable and splices can be damaged as the pump is lowered into the well. To electrically test them, attach one lead of ohmmeter to pipe. Attach other lead to each cable lead in turn. See motor owner's manual for required resistance in a good motor. A low reading indicates that cable or splice has developed a leak to ground. Remove pump from well and correct problem before proceeding with installation.

INSTALLATION

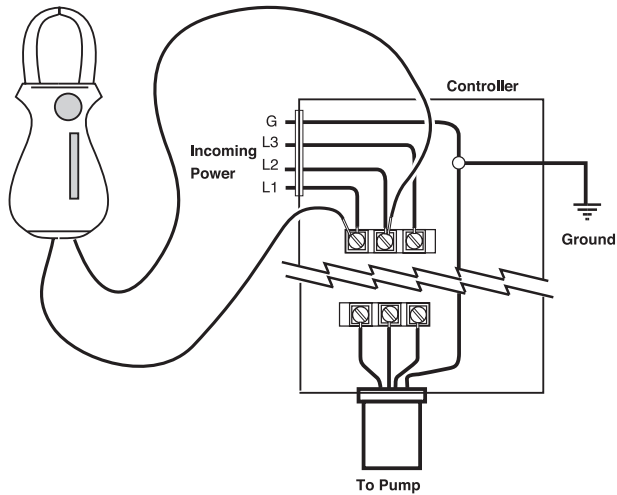

Figure 3: Voltage Test

Measure electrical resistance between motor leads and well casing when motor is cold.

VOLTAGE TEST (FIGURE 3)

Low or high voltages can cause motor failure. While pump is operating, check voltage across each pair of leads at motor controller. Readings more than 10% above or below rated nameplate voltage can damage pump; correct before placing pump in service. Test as follows:

1. Disconnect main power supply and open controller.
2. Connect power and start pump. For 3-phase motors, read voltage across three pairs of leads (L1 - L3, L3 - L2, L2 - L1) while pump is operating. For single phase motors, read voltage across L1 and L2 while pump is operating. Voltage should be within $\pm 10\%$ of motor nameplate rated voltage. If not, consult power company.

LOAD CURRENT TEST (FIGURE 4)

Load current should be obtained on each motor lead at the controller. Partially close pump discharge valve (keep pressure and flow within specified operating range) until maximum amp reading has been obtained. Compare reading with motor nameplate rating. If reading is 15% or more over rated load, check for incorrect voltage in supply line or overload due to abrasives in pump. Find and correct problem before putting pump in service.

CURRENT UNBALANCE EXAMPLE AND WORKSHEET

3-Phase Current Unbalance - Example

Here is an example of current readings at maximum pump loads on each leg of a three wire hookup. Make calculations for all three possible hookups.

A. For each hookup, add the readings for the three legs:

Ex.: Hookup #1	Hookup #2	Hookup #3
L1= 51Amps	L1= 50 Amps	L1= 50 Amps
L2= 46 Amps	L2= 48 Amps	L2= 49 Amps
L3= 53 Amps	L3= 52 Amps	L3= 51 Amps
Total 150 Amps	Total 150 Amps	Total 150 Amps

B. Divide each total by three to get average amps:

Example: $150/3 = 50$
 Example: $150/3 = 50$
 Example: $150/3 = 50$

C. For each hookup, find current value farthest from average (Calculate the greatest current difference from the average).

Ex. #1	Ex. #2	Ex. #3
50 Amps	50 Amps	50 Amps
-46 Amps	-48 Amps	-49 Amps
= 4 Amps	= 2 Amps	= 1 Amps

D. Divide this difference by the average and multiply by 100 to obtain the percentage of unbalance. Example:

Ex. 1: $4/50 = .08 \times 100 = 8\%$
 Ex. 2: $2/50 = .04 \times 100 = 4\%$
 Ex. 3: $1/50 = .02 \times 100 = 2\%$

Use smallest percentage unbalance, in this case Ex. 3.

3-Phase Current Unbalance - Worksheet

Use this worksheet to calculate current unbalance for your installation.

A. Add the readings for the three legs:

Ex.: Hookup #1	Hookup #2	Hookup #3	
L1=	AmpsL1=	AmpsL1=	Amps
L2=	AmpsL2=	AmpsL2=	Amps
L3=	AmpsL3=	AmpsL3=	Amps
Total	Amps Total	Amps Total	Amps

B. Divide each total by three to get average amps:

Hookup #1: $/3 =$
 Hookup #2: $/3 =$
 Hookup #3: $/3 =$

C. For each hookup, find current value farthest from average (Calculate the greatest current difference from the average).

Hookup #1	Hookup #2	Hookup #3	
Amps	Amps	Amps	Amps
Amps	Amps	Amps	Amps
Amps	Amps	Amps	Amps

D. Divide this difference by the average to obtain the percentage of unbalance:

Hookup #1: $/$ = $\times 100 =$ %
 Hookup #2: $/$ = $\times 100 =$ %
 Hookup #3: $/$ = $\times 100 =$ %

Use hookup with smallest percentage unbalance.

SERIES	INLET SHAFT SPACER KEY NO. 19	THRUST SHAFT SPACER KEY NO. 15	DISTANCE SLEEVE KEY NO. 10	STAGE SPACER KEY NO. 10	DISCH. SHAFT SPACER KEY NO. 7	BEARING JOURNAL KEY NO. 6
115	3.738(89.30)	1.356(34.44)	2.896(73.56)	4.37(111.00)	0.620(15.74)	1.749(44.40)
155	3.687(93.65)	1.407(35.74)	2.845(72.28)	4.37(111.00)	0.671(17.04)	1.749(44.40)
230	3.789(96.24)	1.295(32.90)	2.957(75.10)	4.37(111.00)	0.577(14.66)	1.749(44.40)
300	3.967(100.75)	0.860(21.85)	3.3917(86.15)	4.37(111.00)	0.400(10.16)	1.749(44.40)

**Table VI: 6TS-Mixed Flow Shaft Spacer and Bearing Journal Lengths in Inches (mm)
(See Exploded View, Page 14)**

GENERAL SERVICE

When installed in a clear well and operated under normal conditions, the submersible turbine pump requires no special maintenance. The hermetically sealed motor is pre-filled and self-lubricating. Completely tested at the factory, it should provide many years of dependable service. The motor is a continuous duty type and can operate continuously for long periods.

REMOVING PUMP FROM WELL

Most pump problems are caused by above-ground electrical problems. Minor control box components or outside electrical difficulties (such as low voltage) can cause a malfunction. Before removing pump from well, check motor windings for damage (check winding resistance with an ohmmeter – see Page 7). Eliminate all above-ground trouble causes before pulling pump. Pull the pump only as a last resort.

SANDLOCKED PUMP

NOTICE: Before pulling pump, make all possible above ground electrical tests. Most submersible pump problems are above ground, not in the pump itself.

NOTICE: Motor failure can result from starting a sandlocked pump. Do not bypass overload circuit or exceed electrical rating when trying to start a siezed pump.

Remove a sandlocked pump from well for cleaning. To prevent pump from locking again when reinstalled, clean the well thoroughly before reinstalling the pump.

CLEANING SANDLOCKED PUMP

1. Insert a reducing bushing in discharge adapter cap to receive a hose coupling.
2. Use a hose to flush pump backwards (discharge to suction). Oscillate shaft backwards and forwards with a pump pliers and backwash pump for several minutes.

CHECKING PUMP PERFORMANCE

Water containing abrasives can cause impeller wear and reduce impeller efficiency, resulting in overload conditions. In such cases, it is necessary to remove the pump from the well and replace the impellers to maintain capacity and pressure. To assure quality and integrity of the unit, have your pump serviced by authorized Berkeley personnel.

ELECTRICAL TEST

The following electrical checks can be made with pump installed.

⚠ WARNING Risk of high voltage electrical shock when testing. Can stun, burn, or kill. Only qualified electricians should perform these tests. When testing, use all normal precautions for the voltages involved.

CIRCUIT (WINDING) RESISTANCE TEST (FIGURE 5)

1. Shut off main power supply and disconnect motor wires.
2. Attach two ohmmeter leads to pairs of cable wires in turn (black and red wires on three wire single phase units). Compare readings with data provided in motor manual.
3. If reading is considerably higher than chart, an open circuit (broken wire) is indicated; if reading is considerably lower, a short circuit is indicated. In either case, remove pump from well and repair unit.

NOTICE: Be sure to include cable and winding resistance. Multiply cable length by the per-foot cable resistance (see Table IV, Page 2) and add winding resistance from motor chart to get total.

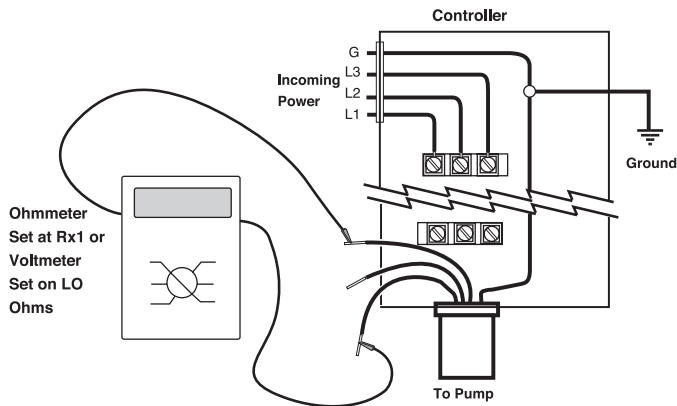

Figure 5: Circuit (Winding) Resistance Test

GROUND CHECK (FIGURE 6)

1. Shut off main power supply and disconnect motor wires.
2. Attach one ohmmeter lead to pipe or METAL well casing and the other lead, in turn, to each individual motor wire.
3. If resistance reading goes to zero after touching any of the wires, the pump should be raised to determine location of ground fault (cable, motor, or splice).
4. Raise pump, watching resistance reading. When resistance goes to infinity, fault has come out of the water. If ground fault is located in cable or splice, repair it.
5. If ground fault appears to be located in motor, remove pump from well. Cut cable at motor side of splice and determine whether or not motor is grounded. If motor indicates complete ground (resistance reading goes to zero) replace unit.

If motor is not grounded, re-check splice and cable.

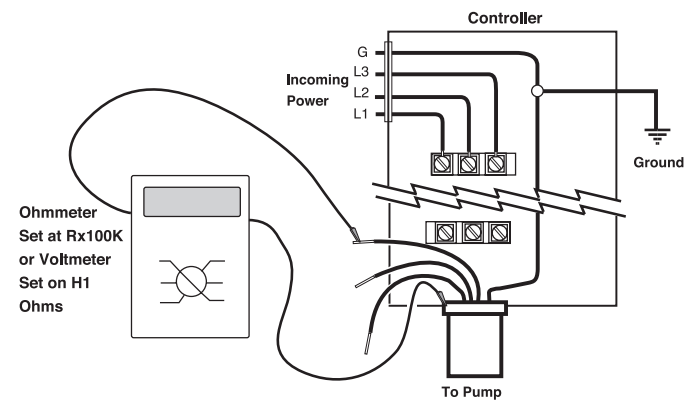

Figure 6: Ground Check

SERVICE

DISASSEMBLY - MIXED FLOW

Please refer to the exploded view on Page 14 for Key No. references.

NOTICE: Do not use any sharp tools that could damage parts. Only gentle tapping with a rubber mallet needs to be applied to release parts.

1. Remove the Cable Guard (Key No. 23) and the Suction and Coupling Strainers (Key Nos. 24 and 26).
2. Loosen and remove the four M12 bolts and washers (Key Nos. 18 and 17) and remove the straps.
3. Gently tap the Discharge (Key No. 1) and remove it.
4. Remove the check valve poppet and the top bowl (Key Nos. 2 and 3).
5. Loosen the Rotor Compression Screw (Key No. 4) in the top of the Shaft (Key No. 27) and remove it.
6. Remove the Rotor Compression Washer, Bearing Journal, and Discharge Shaft Spacer (Key Nos. 5, 6, and 7) from the Shaft.
7. Tap the remaining Bowls (Key No. 9) with a rubber mallet to loosen them. Slide the Bowls, Impellers, and Stage Spacers (Key Nos. 8, 9 and 10) off the Shaft.
8. When you get to the bottom stage, remove the Stainless Washer, Fiber Washer, Thrust Washer, Distance Sleeve, Thrust Spacer, Impeller, First Stage Adapter, and Inlet Shaft Spacer from the Shaft (Key Nos. 12, 13, 14, 11, 15, 8, 20, and 19).
9. Finally, remove the coupling from the Pump Shaft.

ASSEMBLY

Please refer to the exploded view on Page 14 for Key No. references.

1. Clean and straighten the Pump Shaft (Key No. 27) until TIR is 50 to 100 microns (.002" to .004").
2. Slide the Coupling (Key No. 28) onto the Pump Shaft until the end of the shaft aligns with the end of the hex portion of the coupling. Lock the Coupling to the Pump Shaft with two Allen Screws (Key No. 29).
3. Install the Shaft in the Suction Bracket.
4. Bolt the Suction Bracket and shaft onto the Assembly Fixture (See Figure 7 for Fixture specifications). Make sure that the Shaft Assembly is correctly aligned and is down solidly on the Fixture.
5. Install the First Stage Adapter (Key No. 20) on the Suction Bracket.
6. Slide the Inlet Shaft Spacer (Key No. 19) down over the Shaft and seat it on the Coupling.
7. Slide an Impeller (Key No. 8) over the Shaft until it rests on the Inlet Shaft Spacer. Follow it with the Thrust Shaft Spacer, Thrust Washer, Distance Sleeve, Fiber Washer, and Stainless Washer (Key Nos. 15, 14, 11, 13, and 12), in that order.
8. Slide the first stage Bowl (Key No. 9) down over the Shaft and seat it on the Suction Adapter.
9. Check the axial clearance of the pump shaft (2.5 to 3 mm or 3/32 to 1/8").
10. Slide an Impeller (Key No. 8) over the Shaft until it rests on the Distance Sleeve. Follow it with a Stage Spacer (Key No. 10).
11. Slide the next Bowl over the Shaft and seat it by gently tapping it with a rubber mallet.
12. Slide an Impeller over the Shaft until it rests on the Stage Spacer. Follow it with another Stage Spacer.
13. Repeat steps 8, 10, 11 and 12, until you have installed all the intermediate stages. You do not need to repeat the axial clearance check at every stage.
14. Slide the last Impeller over the Shaft until it rests on the Stage Spacer. Follow it with the Discharge Shaft Spacer and the Bearing Journal (Key Nos. 7 and 6).

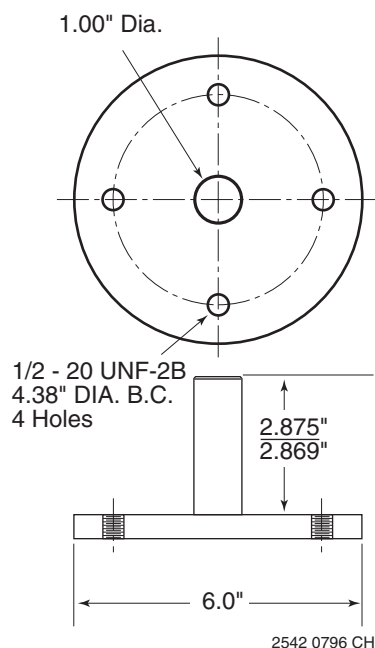

Figure 8: Assembly fixture dimensions for 6" motor; stickup is motor height

SERVICE

15. Put the Rotor Compression Washer (Key No. 5) on the Discharge Spacer and lock it with the Rotor Compression Capscrew (Key No. 4).

NOTE: Use Loctite Threadlocker® on the capscrew threads.

16. Slide the Top Bowl over the shaft and seat it.
17. Install the Check Valve Poppet on top of the last Bowl.
18. Install the Discharge (Key No. 1) on the Top Bowl and seat the assembly by gently tapping it with a rubber mallet. Be sure that the strap slots in the discharge are clean.
19. Hook the four Straps (Key No. 21) into the Discharge and loosely fasten them to the Suction Bracket Assembly with Lock Washers (Key No. 17), Hex Head Bolts (Key No. 18), and Strap Nuts (Key No. 16).

20. Tighten the four Straps evenly to 45 ft.-lbs. torque. Be sure that the Straps seat completely in the discharge.
21. Check the axial clearance of the pump shaft (2.5 to 3 mm. or 3/32 to 1/8").
22. Check for free rotation of the pump stack.
23. Install the Suction Strainer (Key No. 24).
24. Install the Cable Guard Clamps and Cable Guard (Key Nos. 22 and 23) on the pump.
25. Remove the pump from the fixture, install the Coupling Screen (Key No. 26), and mount the pump on the motor.

The pump is ready for installation.

PREVENTIVE MAINTENANCE

To avoid major repairs, make the checks listed below every 4 to 6 months.

Test	Result Should Be	Possible Indications
1. Measure and record the standing water level (from top of well casing).	1. Reference number.	1. To aid in monitoring pump performance.
2. Measure electrical resistance between motor leads and well casing with motor cold.	2. See motor manual.	2. See motor manual.
3. Check pump flow capacity (gallons per minute).	3. At least 90% of readings at installation.	3. Lower readings may indicate pump needs repair.
4. Check pump discharge pressure (PSI) at operating conditions.	4. At least 90% of readings at installation.	4. Lower reading indicates pump wear, increased friction losses, or change in standing water level in well.
5. Check drawdown level (in feet) from standing water level.	5. High enough so that pump does not break suction.	5. Cavitation can damage pump; increased drawdown may indicate reduced well flow.
6. Measure voltage across motor leads while pump is operating.	6. Within ±10% of rated voltage.	6. If voltage is more than 110% or less than 90% of rated voltage, consult power company.

REPAIR PARTS LIST

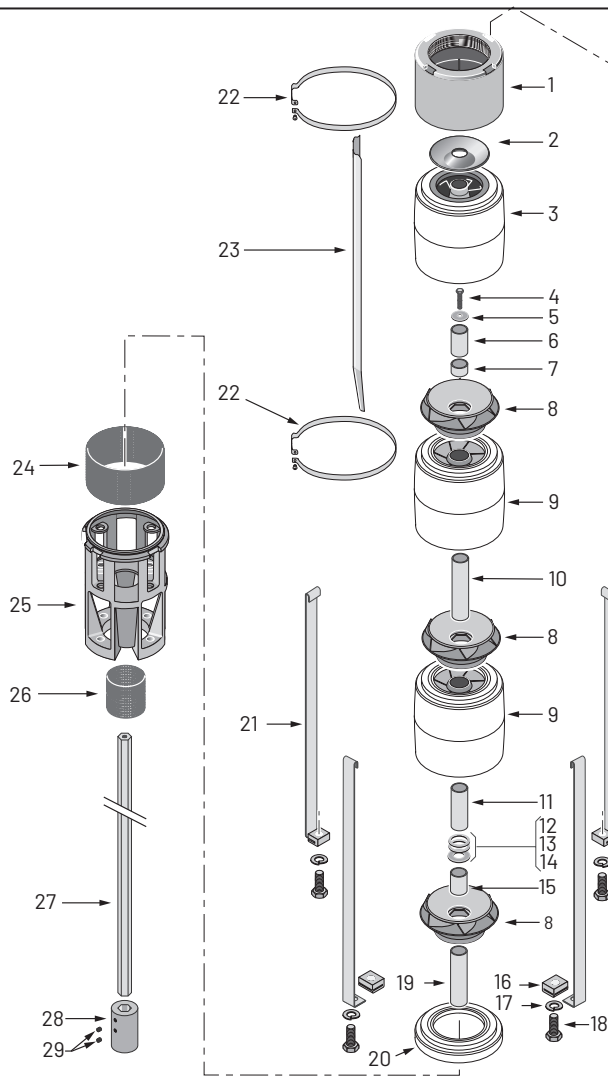

6TS-115, 6TS-155, 6TS-230 and 6TS-300 Series - Mixed Flow Submersible Turbine Pumps

KEY	DESCRIPTION	QTY.	KEY	DESCRIPTION	QTY.
1	Discharge	1	16	Strap Nut	4
2	Check Valve Poppet	1	17	Lock Washer	4
3	Top Bowl	1	18	Strap Capscrew	4
4	Stack Compression Capscrew	1	19	Inlet Shaft Spacer	1
5	Stack Compression Washer	1	20	First Stage Adapter	1
6	Bearing Journal	1	21	Strap	4
7	Discharge Shaft Spacer	1	22	Cable Guard Bracket	2
8	Impeller	*	23	Cable Guard	1
9	Bowl w/ Diffuser	*	24	Suction Screen	1
10	Stage Spacer	*	25	Suction Bracket	1
11	Distance Sleeve	1	26	Coupling Guard	1
12	Stainless Washer	1	27	Shaft	1
13	Fiber Washer	1	28	Coupling	1
14	Thrust Washer	1	29	Coupling Set Screws	2
15	Thrust Shaft Spacer	1			

*Quantity determined by number of stages,

TROUBLESHOOTING

⚠ WARNING Hazardous voltage. Can shock, burn, or kill.
When troubleshooting or servicing pump, use all normal precautions for the voltages involved.

1. Disconnect power unless required for testing.
2. Have electrical testing done by a qualified electrician.
3. Most problems occur above ground. Remove pump from well only as a last resort.

PROBLEM	POSSIBLE CAUSE	REMEDY
Fuses blow or overload circuit breaker trips when motor starts:	<ol style="list-style-type: none"> 1. Pump sandlocked. 2. Low or high voltage. 3. Cable damaged or shorted. 4. Pump forced into crooked well. 	<ol style="list-style-type: none"> 1. a) Check motor winding resistance - see "Circuit (Winding) Resistance", Page 6. b) If motor is not shorted, turn on current and rap discharge pipe sharply to loosen sand. c) Pull pump and clean. 2. Check line voltage (see Page 4). If high or low, contact power company. 3. Check pump cable for ground (see Page 6). 4. Forcing pump into a crooked hole will cause misalignment of pump and motor. Consult well driller.
Fuses blow or overload trips while motor is running:	<ol style="list-style-type: none"> 1. Low or high voltage. 2. Water contains abrasives. 3. Motor or cable shorted and/or grounded. 	<ol style="list-style-type: none"> 1. Check voltage on service lines (see Page 4). 2. If water contains excessive sand, remove pump and clean sand out of well. 3. See "Circuit (Winding) Resistance Test" and "Ground Check", Page 6.
Motor does not start but does not blow fuses or trip circuit breaker:	<ol style="list-style-type: none"> 1. Fuses blown or circuit breaker tripped. 2. Voltage does not reach terminals. 3. Loose wire in control box. 4. Defective magnetic controller coil. 	<ol style="list-style-type: none"> 1. Reset circuit breakers or replace fuses. 2. 3-Phase: Check voltage at controller between wire pairs: L1 - L3, L3 - L2, L2 - L1. Single Phase: Check voltage between L1 and L2 on box terminal strip. 3. Check and tighten all wires. 4. Check starter and coil.
Pump does not shut off:	<ol style="list-style-type: none"> 1. Cable leads improperly connected. 	<ol style="list-style-type: none"> 1. Check wiring diagram on box cover for correct connections.
Motor runs, but delivers little or no water:	<ol style="list-style-type: none"> 1. Horizontal line check valve installed backwards. 2. Motor running backwards (3-Phase only). 3. Pump gaslocked. 4. Water level in well has dropped. 5. Leak in discharge pipe. 6. Coupling between motor shaft and pump shaft broken. 7. Pump parts worn from abrasives. 8. Intake screen clogged. 9. Pump set below recommended depth. 10. Discharge pipe friction reduces output. 	<ol style="list-style-type: none"> 1. Reinstall correctly. 2. Reconnect motor for proper rotation (see Page 3). 3. Start and stop pump several times allowing one minute between stops and starts. 4. a) Restrict pump flow to equal well production. b) Install liquid level control. c) Reset pump lower in well. 5. Raise pipe until leak is found. 6. Remove pump from well and check coupling. If broken, call Berkeley Pumps. 7. a) Check pump shut-off pressure. Pressure should be at least 90% of pressure at installation. b) Call Berkeley Pumps. 8. Remove pump from well and clean screen. 9. a) Reduce pressure switch setting until pump will shut off. b) Install pump producing higher pressure. 10. Install larger pipe or pump producing higher pressure.

Warranty

Pentair BERKELEY® warrants to the original consumer purchaser (“Purchaser” or “You”) of the products listed in the table below, that they will be free from defects in material and workmanship for the Warranty Period shown in the table below.

Product	Warranty Period
Water Systems:	
Water Systems Products – jet pumps, small centrifugal pumps, submersible pumps and related accessories	<i>whichever occurs first:</i> 12 months from date of original installation, or 18 months from date of manufacture
Pentair Pro-Source® Composite Tanks	5 years from date of original installation
Pentair Pro-Source Steel Pressure Tanks	5 years from date of original installation
Pentair Pro-Source Epoxy-Lined Tanks	3 years from date of original installation
Agricultural/Commercial:	
Centrifugals - close-coupled motor drive, frame mount, SAE mount, engine drive, VMS, SSCX, SSHM	12 months from date of original installation, or 24 months from date of manufacture
Submersible Turbines, 6” diameter and larger	12 months from date of original installation, or 24 months from date of manufacture

Our warranty will not apply to any product that, in our sole judgement, has been subject to negligence, misapplication, improper installation, or improper maintenance. Examples that may result in denial of a warranty claim (this list is not all inclusive):

- Damage caused by careless handling, improper repackaging, or shipping.
- Damage due to misapplication, misuse, abuse, or failure to operate equipment as specified in the owner’s manual.
- Damage caused by failure to install products as specified in the owner’s manual.
- Damage due to unauthorized product modifications or failure to use Pentair original replacement parts.
- Damage caused by negligence, or failure to properly maintain products as specified in the owner’s manual.
- Damage caused by water freezing inside the product.
- Accidental damage, fire, acts of God, or other circumstances outside the control of Pentair.

Without limiting the foregoing, operating a three phase motor with single phase power through a phase converter will void the warranty. Note also that three phase motors must be protected by three-leg, ambient compensated, extra-quick trip overload relays of the recommended size or the warranty is void.

All impeller diameters specified in the BEC2 pump sizing program have been tested and determined to not exceed the service factor of the specified motor. Oversized impeller diameters can be requested, however, use of an oversized impeller will void any warranty claims.

Your only remedy, and BERKELEY’s only duty under this warranty, is that BERKELEY repair or replace defective products (at BERKELEY’s choice). THE REMEDIES DESCRIBED HERE ARE YOUR SOLE AND EXCLUSIVE REMEDIES AND OUR ENTIRE LIABILITY FOR ANY BREACH OF THIS WARRANTY.

You must pay all labor and shipping charges associated with the warranty and must request warranty service through the installing dealer as soon as a problem is discovered. No request for service will be accepted if received after the Warranty Period has expired. This warranty is not transferable.

BERKELEY’S LIABILITY SHALL UNDER NO CIRCUMSTANCES EXCEED THE ACTUAL AMOUNT PAID BY YOU FOR THE PRODUCT AT ISSUE. BERKELEY SHALL NOT, UNDER ANY CIRCUMSTANCES, BE LIABLE FOR ANY CONSEQUENTIAL, INCIDENTAL, SPECIAL, PUNITIVE, OR CONTINGENT DAMAGES OR LOSSES WHATSOEVER, WHETHER DIRECT OR INDIRECT. THE FOREGOING WARRANTY IS EXCLUSIVE. EXCEPT FOR THE WARRANTY SET FORTH HEREIN, BERKELEY MAKES NO WARRANTY WHATSOEVER WITH RESPECT TO THE PRODUCTS, INCLUDING, BUT NOT TO ANY WARRANTIES OF MERCHANTABILITY OR WARRANTY OF FITNESS FOR A PARTICULAR PURPOSE, WHETHER EXPRESS OR IMPLIED BY LAW, COURSE OF DEALING, COURSE OF PERFORMANCE, USAGE OF TRADE OR OTHERWISE.

THE FOREGOING WARRANTIES SHALL NOT EXTEND BEYOND THE DURATION PROVIDED HEREIN. Some states do not allow the exclusion or limitation of incidental or consequential damages or limitations on the duration of an implied warranty, so the above limitations or exclusions may not apply to You. This warranty gives You specific legal rights and You may also have other rights which vary from state to state.

This Warranty is effective July 14, 2020 and replaces all undated warranties and warranties dated before July 14, 2020.

BERKELEY

293 Wright Street, Delavan, WI 53115

Phone: 888-237-5353 • Fax: 800-321-8793 • Pentair.com/Berkeley
In Canada: 490 Pinebush Road, Unit 4, Cambridge, Ontario N1T 0A5
Phone: 800-363-7867 • Fax: 888-606-5484



293 Wright Street | Delavan, WI 53115 | Ph: 888-237-5353 | Orders Fax: 800.321.8793 | pentair.com

All indicated Pentair trademarks and logos are property of Pentair. Third party registered and unregistered trademarks and logos are the property of their respective owners. Because we are continuously improving our products and services, Pentair reserves the right to change specifications without prior notice. Pentair is an equal opportunity employer.

P524 (08-01-2020) ©2020 Pentair. All Rights Reserved.