

# Turf Pump Impeller Replacement Kit



### ⚠ WARNING

**Hazardous voltage.**  
Can shock, burn, or cause death.

Disconnect pump from power supply before beginning procedure.

### Description

The components supplied with this turf pump impeller replacement kit are applicable to models SSHM-2 and DSS4HG only. Please read this entire procedure before commencing work.

**NOTICE:** If motor is replaced, always replace the shaft seal and O-Rings. Keep a seal and O-Rings on hand for future use. Be sure to prime pump before starting, as described in the pump owner's manual. The mechanical shaft seal in the pump is water lubricated and self-adjusting.

### Pump Disassembly

Ref. No. references are shown in Figure 1.

**NOTICE:** Do not disturb the recirculation valve (Ref. No. 19). It is NOT a drain plug!

1. Shut off and disconnect power to the pump before working on it.
2. Close all suction and discharge valves to isolate the pump before proceeding further.
3. Remove the hex head drain plug (Ref. No. 17) from the suction body and drain the pump.
4. Disconnect the suction line.
5. Remove four cap screws (Ref. No. 18) from the pump (see Figure 2).

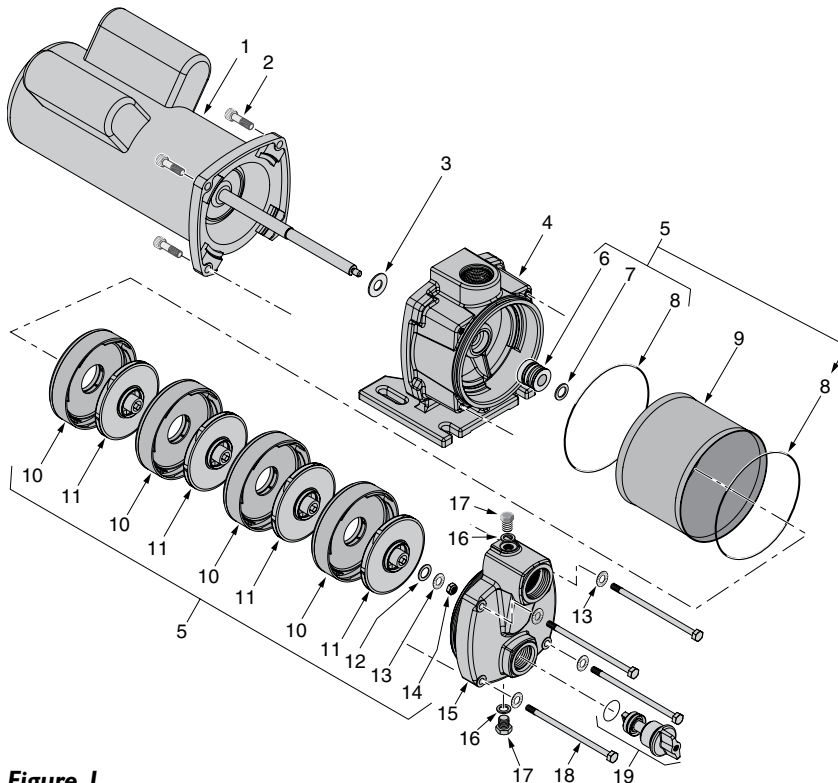

Figure 1

Ref.	Part Description	Qty.
1	Motor	1
2	Socket Head Capscrew	4
3	Slinger	1
4	Bracket	1
5	Impeller Repair Kit (Includes Ref. Nos. 6-8 and 10-14)	1
6	Shaft Seal	1
7	Spacer	1
8	O-Ring	2
9	Sleeve	1
10	Diffuser	4
11	Impeller	4
12	Washer, Flat	1
13	Washer, Toothed	5
14	Impeller Nut	1
15	Pump Body (Suction)	1
16	Washer	2
17	Pipe Plug	2
18	Capscrew	4
19	Recirculation Valve Complete (Includes O-Ring)	1

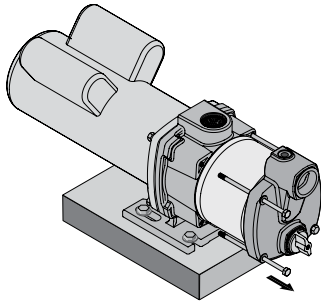

Figure 2

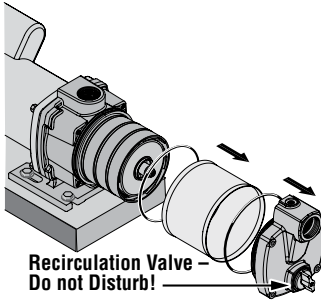

Figure 3

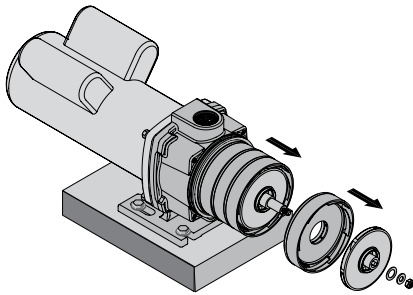

Figure 4

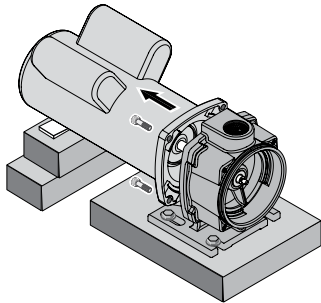

Figure 5

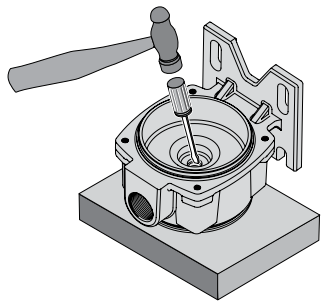

Figure 6

6. Pull the pump suction body forward (see Figure 3). Remove the sleeve (Ref. No. 9) by pulling it straight forward. Be careful to not damage the O-rings on the bracket and suction body.
7. Remove the motor canopy. Hold the motor shaft with a 7/16" open end wrench and remove the nut and two washers (Ref. Nos. 14, 13, 12) from the end of the shaft. See Figure 4.
8. Slide the impellers and diffusers (Ref. Nos. 11, 10) off of the shaft (Figure 4).
9. Slide the spacer (Ref. No. 7) off of the shaft, then pull the rotating half of the seal (Ref. No. 6) forward on the shaft and remove it.
10. Support the motor so that the shaft is free of the weight of the motor when you loosen the cap screws holding the motor to the bracket. Remove four cap screws (Ref. No. 2), and slide the motor and shaft out of the bracket (see Figure 5).

**NOTICE:** To avoid bending the motor shaft, be sure that the shaft does not take the weight of the motor as you remove it.

## Seal Removal

1. Follow the instructions under "Pump Disassembly", above.
2. Remove the discharge pipe from the bracket (Ref. No. 4).
3. Remove the hold down bolts from the bracket.
4. Turn the bracket motor side up on the bench and use a screwdriver to carefully tap the stationary seal half out of the bracket (see Figure 6).
5. Clean the seal seat cavity in the bracket.

## Notes

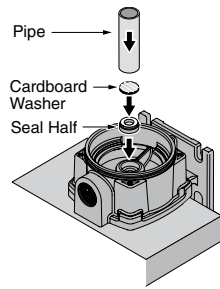

**Figure 7**

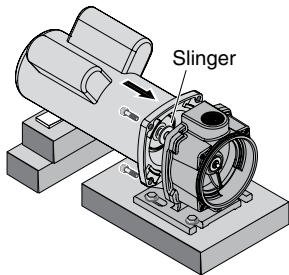

**Figure 8**

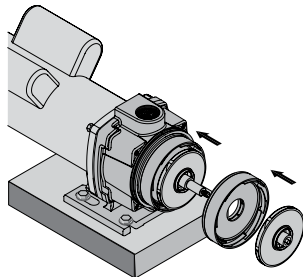

**Figure 9**

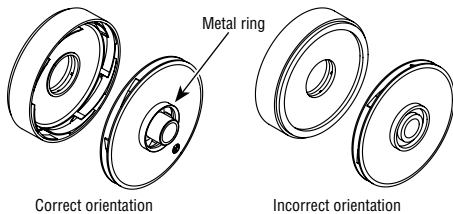

**Figure 10**

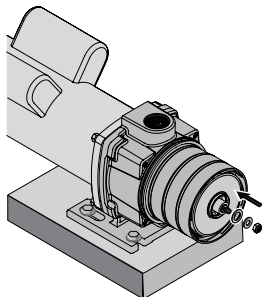

**Figure 11**

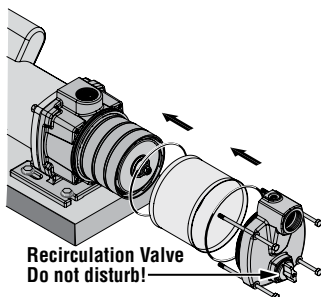

**Figure 12**

## Seal Installation

1. Turn the bracket pump side up on the bench. You will need to block it up to do this (See Figure 7).
  2. Clean the seal cavity in the bracket.
  3. Wet the outer edge of the rubber cup on the ceramic seat with liquid soap. Be sparing!
  4. Put a clean cardboard washer on the seal face. With thumb pressure, press the ceramic seal half firmly and squarely into the seal cavity. The polished face of the ceramic seat is up. If the seal will not seat correctly, remove it, placing the seal face up on the bench. Reclean the cavity. The seal should now seat correctly.
  5. If the seal does not seat correctly after recleaning the cavity, place a clean cardboard washer over the polished seal face and carefully press it into place using a piece of standard 3/4" pipe as a press. See Figure 7.
- NOTICE:** Be sure you do not scratch the seal face.
6. Dispose of the cardboard washer and recheck the seal face to be sure it is free of dirt, foreign particles, scratches and grease.
  7. Inspect the motor shaft to be sure it is free of nicks and scratches.

## Pump Reassembly

1. Bolt the bracket down to the foundation (see Figure 8).
  2. Slide the motor shaft through the seal and bolt up the motor (see Figure 23). Make sure that the slinger is on the shaft between the bracket and the motor flange. Make sure that you don't chip the seal face with the shaft shoulders and that the shaft does not take the weight of the motor at any time.
  3. CAREFULLY slide the rotating seal half onto the shaft, seal face first. Make sure that you don't chip the seal face on the shaft shoulders.
  4. Follow the seal half with the spacer (Ref. No. 7). Slide the washer up against the seal.
  5. Slide a diffuser onto the shaft (open face out) until it seats on the bracket (see Figure 9). Follow the diffuser with an impeller. Engage the molded impeller key in the slot in the shaft. Don't force it! Be sure that the impeller eye, with metal ring, faces out (forward - see Figure 10).
  6. Repeat step 4 with the remaining impellers and diffusers.
  7. Reinstall the toothed washer, the flat washer, and the impeller nut (in that order – Ref. Nos. 12,13,14) onto the motor shaft (see Figure 11). Hold the shaft and tighten the impeller nut to 10 ft.-lbs. torque.
  8. Check the sleeve O-Rings; if they show any damage or wear, replace them. Reinstall the sleeve O-Rings (Ref. No. 8) on the bracket and the suction body.
  9. Reinstall the sleeve on the bracket and the pump suction body in the sleeve. Be sure that you do not pinch or damage the O-Ring. See Figure 27.
  10. Install four cap screws (Ref. No. 18) through the pump head and into the bracket. Tighten the cap screws to 22 ft.-lbs. torque.
  11. Reinstall the drain plug and washer (Ref. Nos. 17 and 16) in the suction body.
- NOTICE:** Do not disturb the recirculation valve.
12. Reinstall the suction and discharge piping and open all valves. Check for leaks.
  13. Prime the pump according to the instructions given in the owner's manual.