



BERKELEY[®] AG SERIES AGRICULTURAL SEWAGE PUMPS

AG3 & AG5 SERIES Agricultural Sewage Pumps

3 & 5 HP, Single Phase, 230 Volt, 1750 RPM

BERKELEY AG Series is designed specifically for use in agricultural lagoon and sewage pit applications.

AG Series pumps are the right choice to handle stringy trash, fibrous wastes, slurries and other difficult to pump solids without plugging. AG Series pumps have been field proven to provide reliable operation and dependable performance. BERKELEY offers a complete line of wastewater pumps, controls and accessories to meet your needs.



Advantages by design

NON-CLOG OPERATION

- ▶ Passes stringy trash, fibrous waste and other difficult solids without plugging the pump
- ▶ Pumping action is by Vortex: solids cannot get caught in volute passage
- ▶ 3" solids handling

STRONG PUMPING PERFORMANCE

- ▶ Heads to 50 feet
- ▶ Capacities to 500 gpm

DURABLE, LONG-LIFE CONSTRUCTION

- ▶ Tough powder-coated finish on liquid end prevents build-up of salt crystals and solids
- ▶ Heavy-duty cast iron construction
- ▶ Heavy-duty motor equipped with thermal overload protection and automatic reset
- ▶ NEMA 4X FRP simplex or duplex pump panels available
- ▶ Double shaft seals and seal leak probe for maximum motor protection
- ▶ All pumps equipped with lifting handle and legs



AG3 & AG5 SERIES

FEATURES

Power cords

SOW-A, UL and CSA approved oil-resistant cable.

Cable entry system

Provides double seal protection. Cable jacket sealed by compression grommet. Individual wires sealed by epoxy potting.

Stator

Heat shrunk into housing for perfect alignment and best heat transfer. Oil-filled motor conducts heat and lubricates bearings.

Shaft seals

Double tandem mechanical shaft seals protect motor. Oil-filled seal chamber provides continuous lubrication.

Recessed impeller

Handles stringy trash and slurries without clogging or binding. Pump out vanes help keep trash from seal; reduces pressure at seal faces.



(Illustration purpose only)

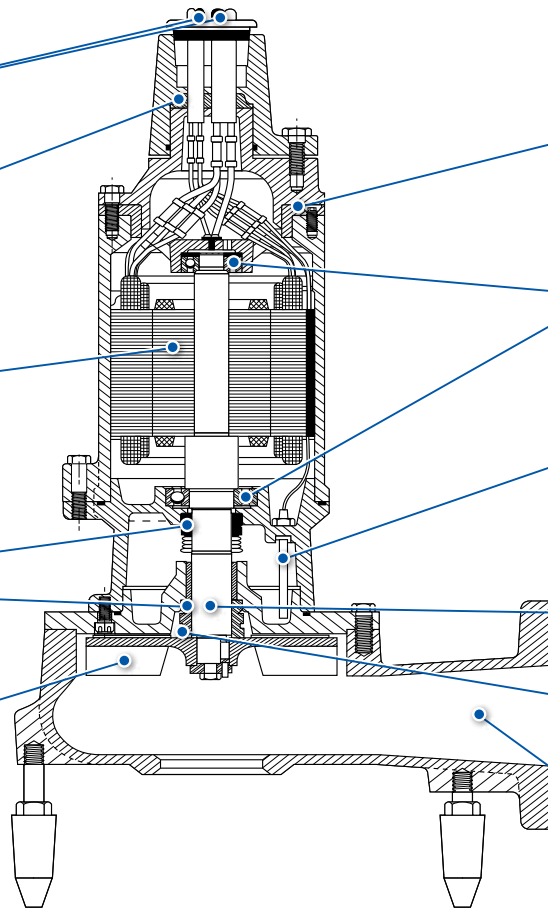

Heat sensor

Protects motor from burnout due to excessive heat from any overload condition. Automatically resets when motor has cooled.

Ball bearings

Upper and lower ball bearings support shaft and rotor and take axial and radial loads.

Seal leak probes

Detect water in seal housing. Activates warning light in control panel. (Test resistor on UL listed models.)

Heavy 416 SST shaft

Corrosion resistant.

Sleeve bearing

Takes radial shock load and provides flame path. (UL listed pumps only.)

Volute case

Handles 3" solids. Completely open from inlet to discharge. 4" ANSI 125 lb. flange.

PERFORMANCE CURVE

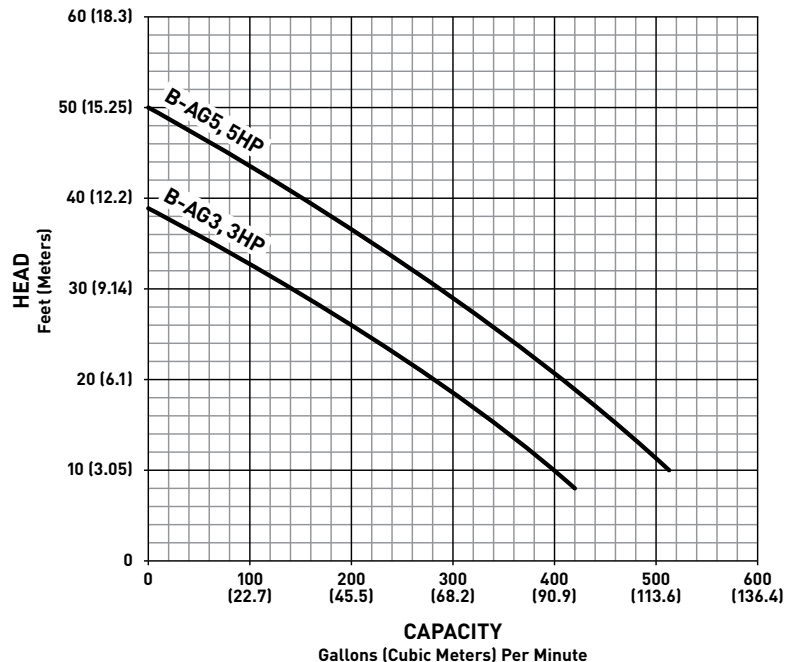

Mercury-Free Float Switch



Simplex Control Panel



Duplex Control Panel

AG3 & AG5 SERIES

TECHNICAL AND ORDERING INFORMATION

Pumps

MODEL	HP	VOLTS	PHASE	HZ	RPM	MAX AMPS	SOLIDS HANDLING	WEIGHT (LBS.)
B-AG3	3	230	1	60	1750	21	39	200
B-AG5	5	230	1	60	1750	41	39	210
B-AG5	5	230	1	60	1750	41	39	210

Controls (required for pump operation)

MODEL	HP	VOLTS	PHASE	TYPE	NEMA	SHIP WEIGHT (LBS.)	FLOAT NEEDED
BCNC3S	3	230	1	Simplex	4X	21	3
BCNC3D	3	230	1	Duplex	4X	35	4
BCNC5S	5	230	1	Simplex	4X	21	3
BCNC5D	5	230	1	Duplex	4X	35	4

Float switches

MODEL	DESCRIPTION	SHIP WEIGHT (LBS.)
SMF25NO	Mercury-free switch sealed in polypropylene float ball weight attached to cord, 25' of 18/2 SJOW/A cord, rated 125VA@115VAC ball colored green	7

Construction materials

PARTS	MATERIALS
Motor housing, seal housing, cord cap and volute case	Cast iron, class 30 ASTM A48-76
Recessed, impeller	3 & 5 HP – ductile iron, class 65 ASTM A536-80
Power and control cord	25 ft. SOW/SOW-A
Mechanical seals	Double tandem, Type 2100 Lower: Silicon carbide/Silicon carbide Upper: Carbon/Ceramic
Pump, motor shaft	416 SST
Fasteners	300 series SST
Motor	1 phase, 230V, 60hz, 1750 rpm, 3 & 5 HP

- All panels have seal leak indicator light.
- CNC simplex single phase panels include: NEMA 4X FRP enclosure, 17-1/2" x 15-7/8" x 7-11/16" overall dimensions; two drawn down hasps with provision for pad locking; switches and indicator lights mounted on dead front full inner door; 2-pole pump circuit breaker; start relay; start capacitor(s); run capacitor(s); IEC rated magnetic contactor; pump H-O-A switch; alarm test switch; amber pump run light; red seal leak indicator light; heat sensor circuit; 1-pole, ambient compensated, quick trip, overload relay; terminal blocks; ground lug; flashing red alarm light (40 watt) with polycarbonate globe; separate alarm and control fuses.
- CNC duplex single phase panels include: NEMA 4X FRP enclosure, 19-5/8" x 17-1/2" x 10-5/8" overall dimensions; two drawn down hasps with provision for pad locking; switches and indicator lights mounted on dead front full inner door; two 2-pole pump circuit breakers; two sets start relays; two sets start capacitors; two sets run capacitors; two IEC rated magnetic contactors; two pump H-O-A switches; alarm test switch; two amber pump run lights; two red seal leak indicator lights; two heat sensor circuits; two 1-pole, ambient compensated, quick trip, overload relays; terminal blocks; ground lug; flashing red alarm light (40 watt) with polycarbonate globe; separate alarm and control fuses; alternator relay; override relays.
- Simplex control panels require three float controls, duplex require four float controls, must be ordered separately.
- Panels meet UL approval, UL label will be installed.

DIMENSIONS

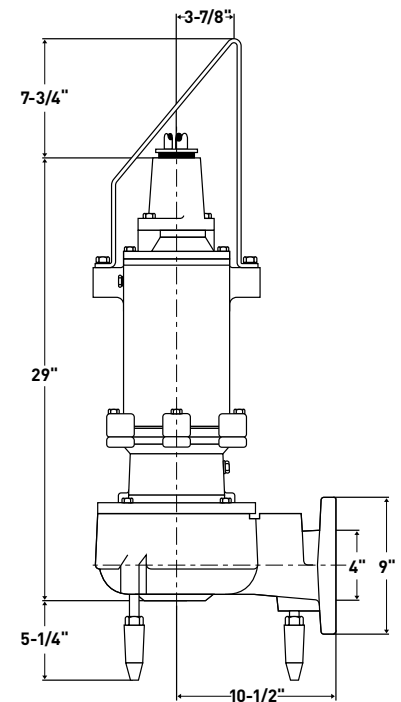
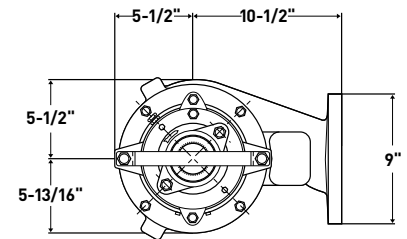

293 WRIGHT STREET, DELAVAN, WI 53115 WWW.BERKELEYPUMPS.COM
PH: 888-237-5353 ORDERS FAX: 800-321-8793

Because we are continuously improving our products and services, Pentair reserves the right to change specifications without prior notice.