



PENTAIR FAIRBANKS NIJHUIS

SINGLE STAGE SPLIT CASE PUMPS
MODEL 1800 SERIES

ENGINEERING DATA
GUIDE

pentair.com

TABLE OF CONTENTS

SECTION.....	PAGE
Mechanical Seals And Packing	3
Interchangeability And Power Series	4
Materials Of Construction	5
Design Details	7
Engineering Data	8

MECHANICAL SEALS AND PACKING

Standard packing on horizontal pumps and the standard mechanical seals on vertical pumps are suitable for most applications. Special sealing arrangements may, however, be required due to higher pressure or temperature requirements and the nature of the liquid to be pumped. Factory option seals are of high quality and supplied by leading mechanical seal manufacturers. Various seal arrangements and types that better suit your specific needs are available. Seal faces are carbon vs. Ni-Resist on standard seals and carbon vs. tungsten carbide on high temperature seals. Corrosion resistant alloy metal parts and Buna-N secondary sealing elements are provided. Various other metals are also available. Gland plates are cast iron and can be supplied in alternative materials. Recommendations and limitations are general. Specific selections can be offered only after rotating speeds, pressures, temperatures, type of equipment and liquid nature are known. The following illustrations describe the basic seal and packing options available. For options not shown refer to the factory. For quick reference for the type of seal best suited to your application, refer to the condensed information that heads each option.

The following comments govern these recommendations:

1. **PACKING** Standard on Model 1820. Not available on 1810 & 1840.
PRESSURES (suction): Below atmospheric up to 250*psig (maximum pump limitation). Lantern rings are required on suction lift applications.
TEMPERATURES: From minus 100°F up to 275°F* with high temperature packing, or 225°F with standard packing.
LIQUIDS: All liquids that are compatible with braided fiber packing. Other packings available for special applications.
2. **SINGLE - UNBALANCED** Standard on Models 1810 and 1840. Optional Model 1820.
PRESSURES (suction): Below atmospheric up to 100 psig.
TEMPERATURES: From minus 100°F up to 275°F with high temperature seals, or 225°F with standard seals.
LIQUIDS: All liquids that are compatible with the seal materials of construction and with a specific gravity higher than .6.
3. **SINGLE - BALANCED** Optional on all models.
PRESSURES (suction): Up to 250 psig (max. pump limit)
TEMPERATURES: Minus 100°F up to 275°F with high temperature seals, or 225°F with standard seals.
LIQUIDS: All liquids that are compatible with the seal materials of construction. Required on liquids with a specific gravity of .6 or lower.

PRESSURES - The pressures referred to are those found at the pump suction. Most seal manufacturers recommend a flushing arrangement from the discharge to the stuffing box where "below atmospheric pressure" is encountered. The 1900 Series first stage stuffing box incorporates an internal bypass arrangement which permits flushing to the mechanical seal. External bypasses are available to both seal faces. An external bypass is standard on vertical pumps to the upper seal face.

TEMPERATURES - The temperature limitation of a mechanical seal is frequently determined by the shaft sealing material. The various elastomer O-ring materials have varying temperature limits, depending upon the chemical and/or physical properties of the process fluid. Filled Teflon†, shaft seal rings are available.

LIQUIDS - Due to varying degrees of resistance of various sealing compounds in different pumped liquids, the following mechanical seal sealing rings are available: Buna-N, neoprene, Viton, Teflon† and other synthetic elastomers.

†DuPont registered trademarks.

*NOTE: Hardened stainless steel(450 minimum Brinell) shaft sleeves are available with this option and are required when the suction pressure is over 100 psig or when the temperature exceeds 225°F.

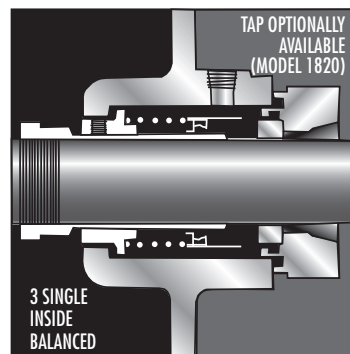
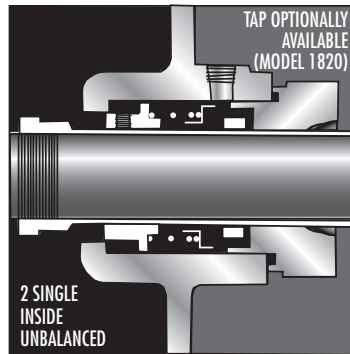
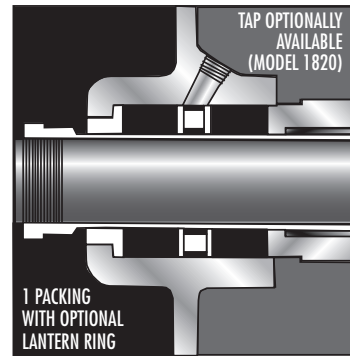

INTERCHANGEABILITY AND POWER SERIES

Fairbanks Nijhuis™ Models 1810, 1820 and 1840 were designed for maximum interchangeability. Each model is available in 34 different sizes, offering a model and size precisely fitted to the installation requirements. The different pump sizes are divided

into 10 power series. Within each power series, all parts are completely interchangeable except for the impeller, casing and case wearing rings for the right-hand or left-hand rotation. See the illustrations below for all details.

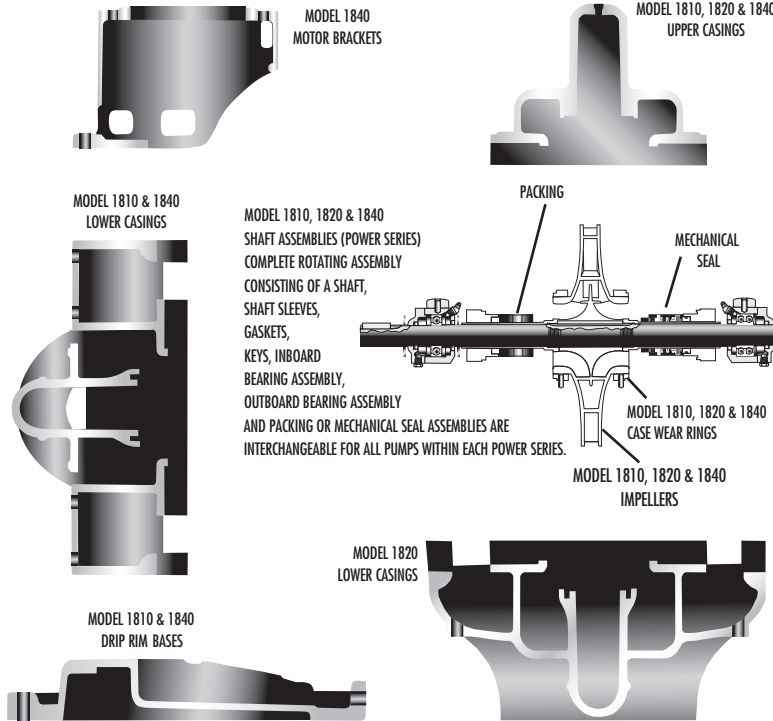

MODEL 1820 POWER SERIES

1	2	3	4	4A	5	5A	6B	7	7A		
2" 1823	2-1/2" 1823B	4" 1823A	—	5" 1824	6" 1822HH	6" 1823	8" 1822	6" 1823HH	10" 1822B	8" 1826	10" 1824D
2" 1824	2-1/2" 1824	4" 1823C	4" 1825B	6" 1822		6" 1824A	—		10" 1823B	12" 1823B	
2" 1825	3" 1824B	4" 1823D	5" 1822A	8" 1821B		6" 1824B	8" 1823A		10" 1823C	12" 1824A	
	3" 1825	4" 1824	5" 1822C			6" 1824C	8" 1823B		10" 1824	14" 1824	
	4" 1822B		5" 1823			6" 1825	8" 1824B				

MODEL 1810 POWER SERIES

1	2	3	4	4A	5	5A	6B	7	7A		
2" 1813	2-1/2" 1813B	4" 1813A	—	5" 1814	6" 1812HH	6" 1813	8" 1812	6" 1813HH	10" 1812B	—	10" 1814D
2" 1814	2-1/2" 1814	4" 1813C	4" 1815B	6" 1812		6" 1814A	—		10" 1813B	12" 1813B	
2" 1815	3" 1814B	4" 1813D	5" 1812A	8" 1811B		6" 1814B	8" 1813A		10" 1813C	12" 1814A	
	3" 1815	4" 1814	5" 1812C			6" 1814C	8" 1813B		10" 1814	14" 1814	
	4" 1812B		5" 1813			6" 1815	8" 1814B				

MODEL 1840 POWER SERIES

1	2	3	4	4A	5	5A	6B	7	7A		
2" 1843	2-1/2" 1843B	4" 1843A	—	5" 1844	6" 1842HH	6" 1843	8" 1842	6" 1843HH	10" 1842B	—	10" 1844D
2" 1844	2-1/2" 1844	4" 1843C	4" 1845B	6" 1842		6" 1844A	—		10" 1843B	12" 1843B	
2" 1845	3" 1844B	4" 1843D	5" 1842A	8" 1841B		6" 1844B	8" 1843A		10" 1843C	12" 1844A	
	3" 1845	4" 1844	5" 1842C			6" 1844C	8" 1843B		10" 1844	14" 1844	
	4" 1842B		5" 1843			6" 1845	8" 1844B				

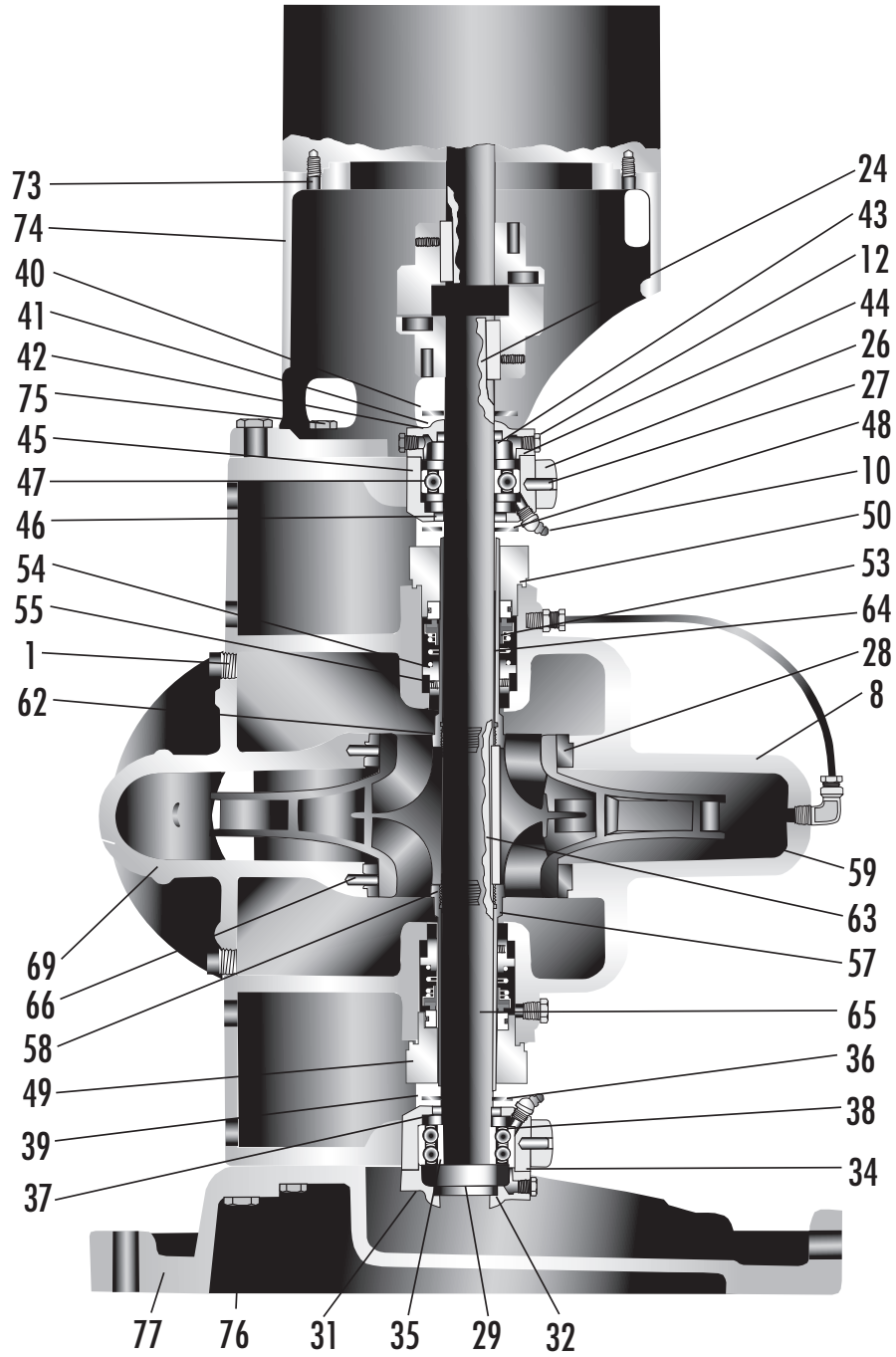

MATERIALS OF CONSTRUCTION

PC NO.	DESCRIP. (*NOTSHOWN)	PUMP CONSTRUCTION		
		BRONZE FITTED	ALL IRON	STAIN. STEEL
1	Plug			
2	*Plug	Mall. Iron A197	Mall. Iron A197	Stain. Stl. AISI 316
6	*Capscrew			
7	*Capscrew	Steel SAE 2	Steel SAE 2	Stain. Stl. AISI 316
8	Casing Half	Cast Iron A48	Cast Iron A48	Stain. Stl. ACI CF8M
9	*Gasket		Buna-N Treated Cellulose	
10	Gr. Ftg.		Steel Zerk	
12	Plug		Malleable Iron ASTM A197	
18	*Nut	Bronze Wrought	Steel SAE 2	Stain. Stl. AISI 316
19	*Washer			
20	*Gland Clamp	Cad. Plated Steel	Cad. Plated Steel	Stain. Stl. AISI 316
21	*Gland	Cast Iron A48	Cast Iron A48	Stain. Stl. ACI CF8M
22	*Swing Bolt	Cad. Plated Steel	Cad. Plated Steel	Stain. Stl. AISI 316
23	*Packing		Graphited Acrylic	
24	Key		Steel Wrought	
25	*Capscrew	Steel SAE 2	Steel SAE 2	Stain. Stl. AISI 316
26	Bearing Cap	Cast Iron A48	Cast Iron A48	Stain. Stl. ACI CF8M
27	Pin	Cad. Plated Steel	Cad. Plated Steel	Stain. Stl. AISI 316
28	Case Ring	Bronze ASTM B62	Cast Iron A48	Stain. Stl. ACI CF8M
29	Protector		Steel Wrought	
31	Capscrew		Steel SAE 2	
32	Cart. Cap		Cast Iron ASTM A48	
34	Gasket		Buna-N Treated Cellulose	
35	Ret. Ring		Spring Steel	
36	Cartridge		Cast Iron ASTM A48	
37	Gr. Seal		Buna-N and Seal	
38	Bearing		Steel Commercial	
39	Slinger		Neoprene	
40	Slinger		Neoprene	
41	Capscrew		Steel SAE 2	
42	Car. Cap		Cast Iron ASTM A48	
43	Gr. Seal		Buna-N and Steel	
44	Gasket		Buna-N Treated Cellulose	
45	Cartridge		Cast Iron ASTM A48	
46	Gr. Seal		Buna-N and Steel	
47	Bearing		Steel Commercial	
48	Slinger		Neoprene	
49	Gland	Cast iron A48	Cast Iron A48	Stain. Stl. ACI CF8M
50	O-Ring		Buna-N	
52	*Lantern Ring	Bronze ASTM B62	Cast Iron A48	Stain. Stl. ACI CF8M
53	Seal	Stain. Stl.(1)	Stain. Stl.(1)	Stain. Stl. (2)
54	Collar	Bronze ASTM B62	Cast Iron A48	Stain. Stl. AISI 316
55	Setscrew		Stainless Steel AISI 316	
56	*Bushing	Bronze ASTM B62	Cast Iron A48	Stain. Stl. ACI CF8M
57	Sleeve	Bronze High Lead Tin		Stain. Stl. AISI 316
58	Gasket		DuPont TFE Coated Steel	
59	Impeller	Bronze ASTM B584	Cast Iron A48	Stain. Stl. ACI CF8M
61	*Imp. Ring	Bronze ASTM B62	A48	ACI CF8M
62	Gasket		DuPont TFE Coated Steel	
63	Key		Stain. Stl. AISI 416	Stain. Stl. AISI 316
64	Sleeve	Bronze High Lead Tin	Bronze High Lead Tin	Stain. Stl. ACI CF8M
65	Shaft	P.S. 1-5	Stl. ASIS C1045	Stain. Stl. AISI 316
		6B-7	Alloy Stl.	(3)
66	Pin			
67	*Pin	Cad. Plated Steel	Cad. Plated Steel	Stain. Steel AISI 416
68	*Pin			
69	Casing Half	Cast Iron A48	Cast Iron A48	Stain. Stl. ACI CF8M
70	*Drive Screw		Steel Bronze Plated	
71	*Nameplate		Stainless Steel AISI 303	
73	Capscrew		Steel SAE 2	
74	Bracket		Cast Iron ASTM A48	
75	Capscrew		Steel SAE 2	
76	Capscrew		Steel SAE 2	
77	Base		Cast Iron ASTM A48	

*All material specifications are in accordance with ASTM unless otherwise noted. (1) B30P6617(JC)(2) XP661C1(JC)(3) AISI 416 chrome steel heat treated power series 6B-7.

DESIGN DETAILS

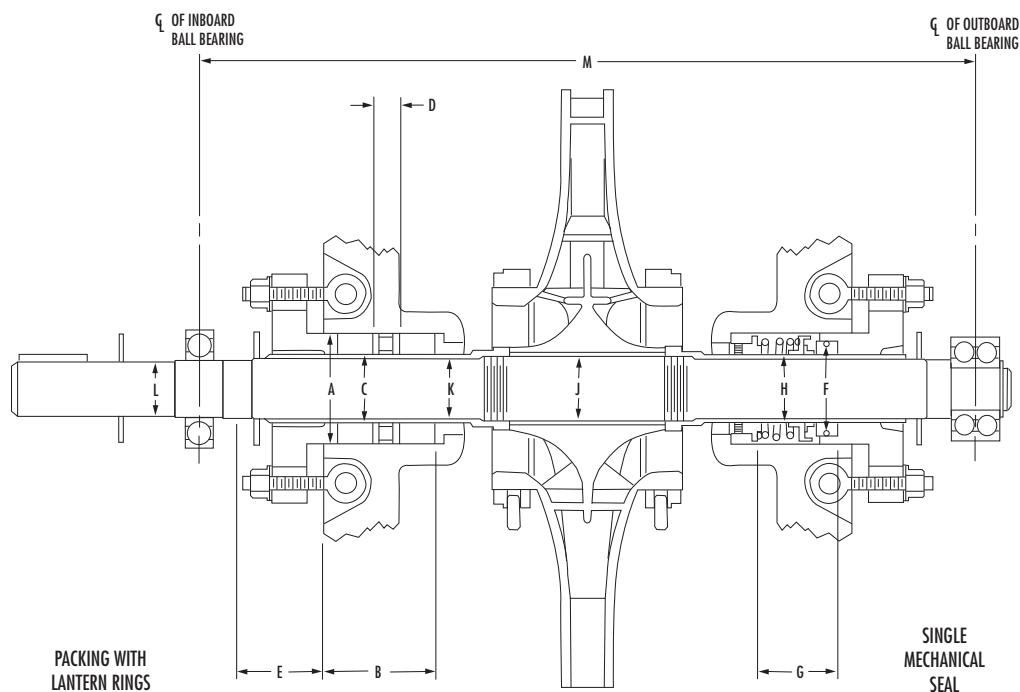

PUMP PART	DIMENSION	POWER SERIES 1	POWER SERIES 2	POWER SERIES 3	POWER SERIES 4	POWER SERIES 4A	POWER SERIES 5	POWER SERIES 5A	POWER SERIES 6B	POWER SERIES 7	POWER-SERIES 7B		
STUFFING BOX	PACKING	A Stuffing Box Bore Dia.	2-1/16	2-7/16	2-13/16	3-1/16	3-1/16	3-7/16	3-7/16	3-11/16	3-15/16	4	
		B Stuffing Box Depth	2-3/8	3-1/8	3	3-1/2	3-1/2	3-3/4	3-3/4	3-3/4	3-7/8	4-3/8	
		C Outside Dia., Sleeve for Packing	1-1/18	1-1/2	1-3/4	2	2	2-3/8	2-3/8	2-1/2	2-7/8	3	
		- No. of Packing Rings without Lantern Ring	10	12	10	12	12	12	12	12	14	12	
		- Total Number of Packing Rings with Lantern Ring	8	10	8	10	10	10	10	10	12	10	
		- No. of Rings in Front of Lantern Ring	1	2	2	2	2	2	2	2	3	2	
		- Packing Size	7/16 Sq.	7/16 Sq.	1/2 Sq.	1/2 Sq.	1/2 Sq.	1/2 Sq.	1/2 Sq.	9/16x1/2	1/2Sq.	1/2 Sq.	
STUFFING BOX	M. SEAL	D Width of Lantern Ring	1/2	5/8	5/8	5/8	5/8	3/4	3/4	3/4	3/4	3/4	
		E Distance from Box to Nearest Obstruction	1-1/4	1-5/8	1-11/16	1-11/16	1-11/16	2	2	2-3/8	2-1/2	2-5/8	
		F Dia. of Mechanical Seal Seat	1-3/4	2-1/8	2-1/2	2-3/4	2-3/4	3-1/4	3-1/4	3-3/8	3-3/4	3-7/8	
		G Length of Mechanical Seal	1-1/2	1-9/16	1-7/8	2	2	2-3/8	2-3/8	2-3/8	2-7/8	3-1/2	
		H Outside Dia., Sleeve for Mech. Seal	1-1/8	1-1/2	1-3/4	2	2	2-3/8	2-3/8	2-1/2	2-7/8	3	
		SHAFT	J Dia. at Impeller (Max. Shaft Dia.)	1-1/8	1-3/8	1-5/8	1-7/8	1-7/8	2-1/8	2-1/8	2-3/8	2-3/4	2-3/4
			K Diameter of Shaft Sleeve	7/8	1-1/4	1-1/2	1-3/4	1-3/4	2	2	2-1/4	2-5/8	2-5/8
L Diameter at Coupling End	3/4		1-1/8	1-3/8	1-1/2	1-1/2	1-3/4	1-3/4	2-1/8	2-1/2	2-1/8		
- Max. Deflection at Sealing Face	.002		.002	.002	.002	.002	.002	.002	.002	.002	.002		
BALL BEARINGS	- Ball Bearing No. (Inboard Radial)	204	206	207	208†	208	309	309	211	213	211		
	- Ball Bearing No. (Outboard Thrust)	5303	5305	5306	5307	5307	5309	5309	5211	5213	5211		
	M Bearing Centers	14-3/4	18-3/8	19-3/8	21-1/4	25-3/8	24	28-1/2	28-3/8	33-1/8	33		
	- Minimum Life of Bearing under Worst Conditions of Load (*)	6 YEARS	6 YEARS	6 YEARS	6 YEARS	6 YEARS	6 YEARS	6 YEARS	6 YEARS	6 YEARS	6 YEARS		

* Average life of bearings is 5 times minimum life

†5208 is provided as standard on 5" 1813B, 5" 1823B, 5" 1843B when operating at 3500 RPM

ENGINEERING DATA

MAXIMUM CASE WORKING PRESSURE is the sum of the differential pressure and the suction pressure. Table 2 indicates the maximum case working pressure for the 1800 Series Split Case Pumps in various materials at the various operating temperatures. These maximum allowable pressures are based on wall thickness for the particular series of pumps, ratings of American Standard Flange Specifications, see Table 1, and take into account the material at various allowable temperatures. Table 1 offers the available casing material and flange ratings for the 1800 Series Split Case Pumps.

EXTERNAL INERTIA OR FLYWHEEL EFFECT is the kinetic energy stored in the rotating assembly that must be overcome when the pump impeller is caused to rotate within the casing. This energy frequently must be calculated to determine the torque required to start, accelerate or decelerate the pump. If the acceleration is rapid, the torque may be several times greater than the torque required to run the pump at normal or constant speed. WR2 values in lbs-ft² are provided for these calculations. See tables 3 through 8.

WR2 values given in table are for bronze impeller...lbft²

Pump Casing Material	Minimum Requirement for standard suction and discharge flanges		Pipe Size	Code
	A.S.A. Spec.	Classification		
Cast Iron ASTM A48	B16.1	125 psi Flat Face	1-12 14-24	A B
		250 psi Flat Face	1-12 14-24	C
Stainless Steel ASTM 296 Grade CF8M	B16.5	150 psi Flat Face	All	E
		300 psi Flat Face		C

Maximum Hydrostatic Pressure 1-1/2 times maximum case working pressure at 100°F

EXAMPLE: A model 1800 pump with a bronze casing has been selected for operating at a case working pressure of 240 psig at 150°F. Enter Table 2 at 150°F and read upward to 240 psig. It is determined that the selection is within the recommended maximum case working pressure area for 300 psi flanges and is therefore acceptable. Note that the example exceeds the maximum case working pressure unit if the material selected would have been 125 psi flanged cast iron or 150 psi flanged bronze.

Table 2

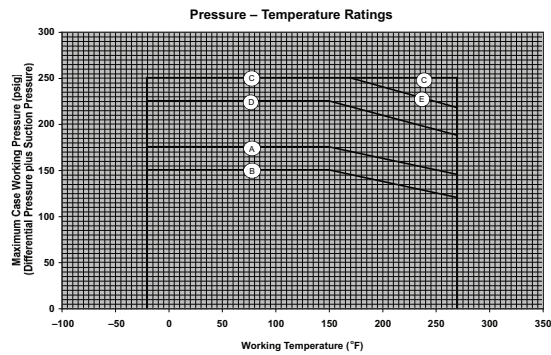

Table 3

METALS	S.G.
Bronze	8.86
Cast Iron	7.20
Carbon Steel	7.84
Stainless Steel	7.90

EXAMPLE 1: Find WR² value for a 15" diameter 8" 1823B bronze fitted pump handling cold water.

From chart find the "WET" value for a 15" diameter impeller10.38 lbs-ft²
 Add power series 5 rotating element less impeller.....0.15 lbs-ft²
 Total 10.53 lbs-ft²

EXAMPLE 2: Find WR² value for a 15" diameter 8" 1823B all iron pump handling 0.67 specific gravity gasoline.

From chart find the "DRY" value and correct for difference in materials.
 SP. GR. cast iron x 9.29 lbs-ft².....7.54 lbs-ft²
 SP. GR. bronze x 9.29 lbs-ft².....7.54 lbs-ft²
 Take difference ("WET"-"DRY") values and correct for difference in specific gravities.
 1.09x0.67 0.73 lbs-ft²
 Add power series 5 rotating element less impeller.....0.15 lbs-ft²
 Total 10.53 lbs-ft²

Table 4

POWER SERIES	WR ²
1	0.006
2	0.020
3	0.038
4	0.075
4A	0.087
5	0.154
5A	0.181
6B	0.294
7	0.536
7A	0.413

ENGINEERING DATA

Table 5

		Pump Sizes									
		2" 1813		2" 1814		2-1/2" 1813B		3" 1814B		4" 1812B	
		2" 1823		2" 1824		2-1/2" 1823B		3" 1824B		4" 1822B	
		2" 1843		2" 1844		2-1/2" 1843B		3" 1844B		4" 1842B	
DIA.		Dry	Wet	Dry	Wet	Dry	Wet	Dry	Wet	Dry	Wet
10"		-	-	-	-	-	-	1.17	1.30	-	-
9.5"		-	-	0.72	0.88	0.84	0.95	0.98	1.10	0.90	1.03
9.0"		0.56	0.63	0.60	0.70	0.70	0.85	0.80	0.90	0.80	0.90
8.5"		0.37	0.43	0.46	0.54	0.62	0.73	0.70	0.75	0.68	0.75
8.0"		0.28	0.32	0.40	0.47	0.56	0.65	0.56	0.60	0.56	0.63
7.5"		0.23	0.26	0.36	0.41	0.47	0.56	0.46	0.50	0.48	0.54
7.0"		0.19	0.22	0.29	0.33	0.42	0.49	0.36	0.40	0.43	0.46
6.5"		0.18	0.19	0.27	0.31	0.39	0.44	0.32	0.36	0.38	0.41
6.0"		0.16	0.18	-	-	0.35	0.41	0.28	0.31	0.33	0.36
IMP. WT.		10#		12#		14#		18#		15#	

Table 6

		Pump Sizes																							
		2" 1815		2-1/2" 1814		4" 1813A		4" 1813C		4" 1813D		5" 1812A		5" 1812C		6" 1812		6" 1812HH		8" 1811B		8" 1812		10" 1812B	
		2" 1825		2-1/2" 1824		4" 1823A		4" 1823C		4" 1823D		5" 1822A		5" 1822C		6" 1822		6" 1822HH		8" 1821B		8" 1822		10" 1822B	
		2" 1845		2-1/2" 1844		4" 1843A		4" 1843C		4" 1843D		5" 1842A		5" 1842C		6" 1842		6" 1842HH		8" 1841B		8" 1842		10" 1842B	
DIA.		Dry	Wet	Dry	Wet	Dry	Wet	Dry	Wet	Dry	Wet	Dry	Wet	Dry	Wet	Dry	Wet	Dry	Wet	Dry	Wet	Dry	Wet	Dry	Wet
12"		1.55	1.82	1.70	1.95	-	-	-	-	-	-	-	-	-	-	-	-	-	-	-	-	-	-	-	-
11.5"		1.25	1.45	1.40	1.55	-	-	-	-	-	-	-	-	-	-	-	-	-	-	-	-	-	-	-	-
11.0"		1.05	1.20	1.10	1.25	1.90	2.10	1.65	1.80	-	-	2.04	2.47	3.00	3.60	2.04	2.47	3.36	2.76	2.15	2.45	3.40	3.80	5.00	5.60
10.5"		0.93	1.04	0.98	1.10	1.60	1.75	1.45	1.55	1.28	1.23	1.80	2.10	2.90	3.20	1.80	2.10	3.03	2.49	1.95	2.20	3.10	3.30	4.90	5.50
10.0"		0.81	0.90	0.83	0.90	1.35	1.52	1.22	1.35	1.18	1.14	1.60	1.85	2.65	3.10	1.60	1.85	2.74	2.25	1.73	1.95	2.85	3.10	4.80	5.40
9.5"		0.75	0.83	0.68	0.75	1.20	1.33	1.08	1.19	1.00	1.05	1.45	1.65	2.50	2.90	1.45	1.65	2.48	2.04	1.50	1.66	2.70	2.90	-	-
9.0"		0.70	0.78	0.60	0.67	1.05	1.22	1.00	1.10	1.09	0.97	1.30	1.45	2.40	2.80	1.30	1.45	2.25	1.86	1.40	1.50	2.60	2.70	-	-
8.5"		-	-	-	-	0.95	1.05	0.88	0.99	0.95	0.89	1.20	1.35	2.35	2.60	1.20	1.35	2.06	1.72	1.30	1.40	2.50	2.60	-	-
8.0"		-	-	-	-	0.83	0.95	0.75	0.84	0.88	0.83	1.06	1.15	2.00	2.40	1.06	1.15	1.90	1.60	1.15	1.20	-	-	-	-
7.5"		-	-	-	-	-	-	0.73	0.80	0.78	0.75	0.93	1.05	1.90	2.20	0.93	1.05	1.78	1.51	1.09	1.12	-	-	-	-
7.0"		-	-	-	-	-	-	0.65	0.74	0.75	0.69	-	-	-	-	-	-	-	-	-	-	-	-	-	-
IMP. WT.		15#		17#		26#		22#		24#		27#		32#		27#		37#		29#		43#		59#	

Table 7

Pump Sizes																				
3" 1815 3" 1825 3" 1845		4" 1814 4" 1824 4" 1844		5" 1813 5" 1823 5" 1843		6" 1813HH 6" 1823HH 6" 1843HH		6" 1813 6" 1823 6" 1843		8" 1813A 8" 1823A 8" 1843A		8" 1813B 8" 1823B 8" 1843B		10" 1813B 10" 1823B 10" 1843B		10" 1813C 10" 1823C 10" 1843C		12" 1813B 12" 1823B 12" 1843B		
DIA.	Dry	Wet	Dry	Wet	Dry	Wet	Dry	Wet	Dry	Wet	Dry	Wet	Dry	Wet	Dry	Wet	Dry	Wet	Dry	Wet
15"	-	-	4.51	5.18	6.18	6.76	-	-	7.39	8.51	7.39	8.51	9.29	10.4	9.20	10.0	14.5	17.5	14.3	17.7
14.5"	-	-	3.80	4.50	5.40	6.00	-	-	6.75	7.50	6.75	7.50	7.75	8.80	8.50	9.25	13.5	16.2	14.0	16.5
14.0"	3.62	4.36	3.50	3.90	4.60	5.20	7.50	6.63	6.00	6.75	6.00	6.75	6.75	7.75	8.00	9.00	12.2	14.4	13.0	15.0
13.5"	3.10	3.60	3.00	3.40	4.20	4.50	6.97	6.16	5.40	6.00	5.40	6.00	6.10	7.00	7.50	8.50	11.3	12.2	12.5	14.5
13.0"	2.70	3.10	2.55	2.95	3.60	3.90	6.46	5.69	5.00	5.50	5.00	5.50	5.70	6.25	6.75	7.60	10.5	11.4	11.8	13.9
12.5"	2.25	2.65	2.20	2.60	3.20	3.50	5.97	5.27	4.50	5.00	4.50	5.00	5.10	5.80	6.50	7.25	10.0	11.0	11.0	13.0
12.0"	1.98	2.30	1.95	2.25	3.05	3.20	5.48	4.83	4.10	4.40	4.10	4.40	4.80	5.30	6.25	7.00	-	-	10.5	12.5
11.5"	1.60	1.90	1.70	2.00	2.70	2.98	5.06	4.45	3.70	4.00	3.70	4.00	4.50	5.00	-	-	-	-	-	-
11.0"	1.40	1.65	1.50	1.75	2.50	2.70	4.62	4.06	3.30	3.55	3.30	3.55	4.10	4.40	-	-	-	-	-	-
10.5"	1.25	1.50	-	-	2.30	2.45	4.23	3.70	3.00	3.20	3.00	3.20	3.70	4.10	-	-	-	-	-	-
10.0"	1.10	1.35	-	-	2.05	2.25	3.87	3.38	2.85	3.10	2.85	3.10	3.50	3.80	-	-	-	-	-	-
9.5"	-	-	-	-	-	-	3.47	3.02	-	-	-	-	-	-	-	-	-	-	-	-
9.0"	-	-	-	-	-	-	3.11	2.69	-	-	-	-	-	-	-	-	-	-	-	-
IMP. WT.	28#		30#		45#		62#		56#		56#		59#		70#		85#		87#	

Table 8

Pump Sizes																				
4" 1815B 4" 1825B 4" 1845B		5" 1814 5" 1824 5" 1844		6" 1814A, B & C 6" 1824A, B & C 6" 1844A, B & C		6" 1815 6" 1825 6" 1845		8" 1814B 8" 1824B 8" 1844B		10" 1814 10" 1824 10" 1844		10" 1814D 10" 1824D 10" 1844D		8" 1826		12" 1814A 12" 1824A 12" 1844A		14" 1814 14" 1824 14" 1844		
DIA.	Dry	Wet	Dry	Wet	Dry	Wet	Dry	Wet	Dry	Wet	Dry	Wet	Dry	Wet	Dry	Wet	Dry	Wet	Dry	Wet
24.0"	-	-	-	-	-	-	-	-	-	-	-	-	-	-	50.1	52.5	-	-	-	-
22.5"	-	-	-	-	-	-	-	-	-	-	-	-	-	-	44.0	46.5	-	-	-	-
21.0"	-	-	-	-	-	-	-	-	-	-	-	-	-	-	38.0	40.5	-	-	-	-
19.5"	-	-	-	-	-	-	18.0	20.3	-	-	-	-	-	-	35.0	35.5	-	-	-	-
19.0"	-	-	-	-	-	-	16.5	19.0	-	-	-	-	-	-	-	-	-	-	-	-
18.5"	-	-	-	-	-	-	15.0	17.2	-	-	-	-	-	-	-	-	-	-	-	-
18.0"	11.6	13.5	-	-	15.0	18.0	14.0	15.4	-	-	19.5	22.6	-	-	-	-	30.0	32.0	46.0	48.0
17.5"	10.8	12.0	-	-	13.0	16.0	12.6	14.3	16.5	18.5	18.5	21.0	27.78	21.29	-	-	25.0	29.0	40.0	42.0
17.0"	10.1	11.1	-	-	11.5	13.5	11.4	13.4	15.2	16.5	17.0	19.5	26.12	20.15	-	-	22.0	26.5	36.0	39.0
16.5"	9.50	10.3	8.64	9.69	10.0	11.6	10.5	12.0	12.6	14.5	15.5	18.5	24.46	19.01	-	-	20.0	24.0	31.0	34.0
16.0"	9.00	9.50	8.00	9.00	8.80	9.70	9.93	11.2	11.5	13.0	14.0	17.1	22.95	17.97	-	-	17.5	21.5	28.0	31.5
15.5"	8.81	8.90	7.30	8.30	7.50	8.80	9.00	10.0	10.0	11.5	13.1	16.0	21.43	16.93	-	-	15.5	19.5	25.0	29.0
15.0"	-	-	6.80	7.80	6.70	7.00	8.10	9.25	9.10	9.90	12.0	14.5	20.08	15.99	-	-	14.0	18.0	22.5	27.5
14.5"	-	-	6.00	7.00	6.00	6.50	7.36	8.28	7.50	8.60	-	-	18.72	15.05	-	-	-	-	-	-
14.0"	-	-	5.30	6.20	-	-	-	-	-	-	-	-	-	-	-	-	-	-	-	-
13.5"	-	-	4.90	5.80	-	-	-	-	-	-	-	-	-	-	-	-	-	-	-	-
13.0"	-	-	4.40	5.20	-	-	-	-	-	-	-	-	-	-	-	-	-	-	-	-
IMP. WT.	28#		30#		45#		56#		59#		70#		166#		105#		85#		87#	

QUIET PUMP SELECTION

Table 9

PUMP SIZES			MAX. IMP. DIA.	CUT-WATER DIA.	QUIET IMP. DIA.	SPHERE SIZE DIA.
2" 1813	2" 1823	2" 1843	9.0	10.4	8-13/16	1/8
2" 1814	2" 1824	2" 1844	9.5	10.3	8-11/16	1/4
2" 1815	2" 1825	2" 1845	12.0	13.3	11-1/4	1/4
2-1/2" 1813B	2-1/2" 1823B	2-1/2" 1843B	9.5	10.3	8-11/16	3/8
2-1/2" 1814	2-1/2" 1824	2-1/2" 1844	12.0	13.3	11-3/8	3/8
3" 1814B	3" 1824B	3" 1844B	10.0	10.5	8-13/16	1/2
3" 1815	3" 1825	3" 1845	14.0	15.4	13-1/16	5/8
4" 1812B	4" 1822B	4" 1842B	9.5	10.6	9-1/16	5/8
4" 1813A	4" 1823A	4" 1843A	11.3	12.8	10-7/8	5/8
4" 1813C	4" 1823C	4" 1843C	11.3	12.8	10-7/8	1/2
4" 1813D	4" 1823D	4" 1843D	11.0	12.8	10-7/8	3/8
4" 1814	4" 1824	4" 1844	15.0	16.4	13-15/16	5/8
4" 1815B	4" 1825B	4" 1845B	18.3	22.6	18-1/4	9/16
5" 1812A	5" 1822A	5" 1842A	11.0	12.6	10-3/4	1
5" 1812C	5" 1822C	5" 1842C	11.0	12.6	10-3/4	5/8
5" 1813	5" 1823	5" 1843	15.0	16.4	13-7/8	13/16
5" 1814	5" 1824	5" 1844	16.5	17.4	14-3/4	11/16
6" 1812	6" 1822	6" 1842	11.0	12.8	10-7/8	1
6" 1812HH	6" 1822HH	6" 1842HH	11.0	11.5	9-3/4	3/4
8" 1811B	8" 1821B	8" 1841B	12.0	13.3	11-1/4	1-1/4
6" 1813HH	6" 1823HH	6" 1843HH	14.0	14.25	12-1/8	11/16
6" 1813	6" 1823	6" 1843	15.0	16.6	14-1/8	15/16
6" 1814A	6" 1824A	6" 1844A	18.0	20.5	17-7/8	1
6" 1814B	6" 1824B	6" 1844B	18.0	20.5	17-7/8	1
6" 1814C	6" 1824C	6" 1844C	18.0	20.5	17-7/8	1
6" 1815	6" 1825	6" 1845	19.5	20.6	17-9/16	13/16
8" 1812	8" 1822	8" 1842	12.0	14.4	12-1/4	15/16
8" 1813A	8" 1823A	8" 1843A	15.0	16.8	14-1/4	15/16
8" 1813B	8" 1823B	8" 1843B	15.0	16.8	14-1/4	1-5/16
8" 1814B	8" 1824B	8" 1844B	17.5	18.5	15-3/4	1-5/16
10" 1812B	10" 1822B	10" 1842B	12.0	14.0	11-15/16	15/16
10" 1813B	10" 1823B	10" 1843B	15.0	17.1	14-9/16	1-7/16
10" 1813C	10" 1823C	10" 1843C	15.0	17.1	14-9/16	1-1/8
10" 1814	10" 1824	10" 1844	18.0	20.5	17-7/16	1-9/16
10" 1814D	10" 1824D	10" 1844D	17.5	18.5	15-3/4	1-5/16
-	8" 1826	-	24	21.6	18-3/8	1
12" 1813B	12" 1823B	12" 1843B	15.0	17.8	15	1-1/16
12" 1814A	12" 1824A	12" 1844A	18.0	21.1	18	1-5/16
14" 1814	14" 1824	14" 1844	18.0	22.0	18	1-1/2

Table 10

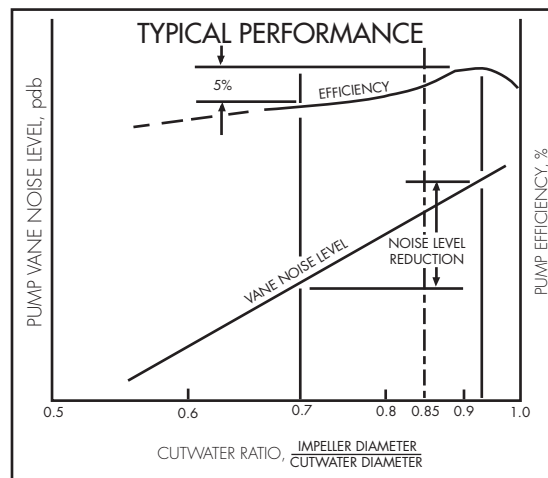

QUIET PUMP SELECTION

QUIET PUMP operation is always desirable and sometimes essential. One of the most important factors for noise control in a pumping installation is the correct selection of a pumping unit for the system. To ensure that the pump will run quietly, it should be selected so that it will operate as close as possible to the best efficiency point. At this point the hydraulic shock within the pump is at a minimum since the flow angle of the fluid from the tip of the impeller is correct for the casing design. Every pump is designed for the best efficiency point, and operations at any other point on the characteristic curves is a compromise. The amount of turbulence on either side of the best efficiency point increases as the point of operation is moved along the curve from the maximum efficiency. Therefore, the greater the turbulence, the greater the noise generated.

Hydraulic shock is also a factor if the periphery of the impeller passes too close to the cutwater. If the ratio of the impeller diameter to the cutwater diameter in centrifugal pumps is greater than 0.92, the pump is likely to be hydraulically noisy. In such instances the hydraulic pulses are actually differential pressures that occur when the impeller vanes pass the cutwater. Cutwater ratios of 0.9 to 0.95 are typical; however, significantly lower noise levels are achieved in pumps designed with a ratio of 0.7 to 0.75. Although there is an optimum gap for pump efficiency, increases of only 3%–5% may be realized by using the optimum. A cutwater ratio of 0.85 is commonly specified by practicing engineers, thereby realizing a minimum reduction in pump efficiency with a mean reduction in noise level. Table 9 offers recommended quiet impeller diameter at 85% cutwater ratio.

BEARING LIFE is based on the radial and thrust loads imposed on the bearings at the specific operating head and suction pressure. The split case pump is designed for a six year minimum B10 life at the maximum recommended loads. Bearing life at any other point of greater capacity on the curves will greatly exceed the minimum life shown. Average bearing life is equal to five (5) times the minimum bearing life. Tables 11, 12, 13, and 14 will enable you to determine the minimum radial and thrust bearing life for any type 1800 Series pump size.

SHAFT DEFLECTION is the consequence of the unbalanced hydraulic force acting inside the pump on the impeller and shaft in a radial direction. This unbalance occurs when the pump is operating away from its best efficiency point. At shutoff condition (zero flow) the unbalance is greatest and therefore the resultant radial load is maximum. Radial load and shaft deflection approach zero at the best efficiency point of the pump. 1800 Series pumps are designed for a maximum deflection of .002" at the mechanical seal faces when operating at the maximum recommended differential pressure. Deflection in a twin volute pump is minimized by a splitter blade that is cast within the casing thereby nearly balancing the resultant forces acting on the shaft. See Table 13.

PROCEDURE FOR DETERMINING MAXIMUM SHAFT DEFLECTION AND MINIMUM BEARING LIFE.

1. Determine the proper pump size, approximate shutoff head in feet, power series number, and speed from the range charts illustrated in the 1800 bulletin.
2. From Table 11 determine the pump size factor based on pump size and RPM.
3. On Table 13 locate the correct shutoff head in feet and read across to the proper pump size factor and down to the applicable power series. Note the load factor in the process. Read to the scale on the left for the maximum shaft deflection value.
4. From Table 14 using the load factor from step 3 above, read across to the correct power series number and down for the minimum bearing life in hours.

NOTE:

One(1) year life is based on 8740 hours(continuous operation).

Additional bearing information can be found on page 4.

Specific information on bearing life and shaft deflection can be obtained from the factory.

SHAFT DEFLECTION AND BEARING LIFE

Table 11

PUMP SIZES			POWER SERIES	PUMP SIZE FACTOR		
				3500 RPM	1750 RPM	1150 RPM
2" 1813	2" 1823	2" 1843	1	0.40	0.50	
2" 1814	2" 1824	2" 1844	1	0.55	0.65	
2" 1815	2" 1825	2" 1845	1	0.65	0.80	
2-1/2" 1813B	2-1/2" 1823B	2-1/2" 1843B	2	1.00	1.00	
2-1/2" 1814	2-1/2" 1824	2-1/2" 1844	2		1.00	1.20
3" 1814B	3" 1824B	3" 1844B	2	1.25	1.50	
3" 1815	3" 1825	3" 1845	2		1.40	1.60
4" 1812B	4" 1822B	4" 1842B	2	1.30	1.40	
4" 1813A	4" 1823A	4" 1843A	3		2.00	2.25
4" 1813C	4" 1823C	4" 1843C	3	1.50	1.70	
4" 1813D	4" 1823D	4" 1843D	3	1.85	4.00	
4" 1814	4" 1824	4" 1844	3		2.00	2.25
4" 1815B	4" 1825B	4" 1845B	4		1.70	1.80
5" 1812A	5" 1822A	5" 1842A	4		4.00	4.50
5" 1812C	5" 1822C	5" 1842C	4	2.00	2.13	
5" 1813	5" 1823	5" 1843	4		3.00	3.25
5" 1814	5" 1824	5" 1844	4		3.00	3.25
6" 1812	6" 1822	6" 1842	4		4.00	4.50
8" 1811B	8" 1821B	8" 1841B	4		5.25	5.50
6" 1813	6" 1823	6" 1843	5		3.75	4.00
6" 1814A	6" 1824A	6" 1844A	5		3.00	3.25
6" 1814B	6" 1824B	6" 1844B	5		2.75	3.50
6" 1814C	6" 1824C	6" 1844C	5		3.75	4.75
6" 1815	6" 1825	6" 1845	5		3.20	3.40
8" 1812	8" 1822	8" 1842	5		3.50	4.00
8" 1813A	8" 1823A	8" 1843A	5		4.00	4.50
8" 1813B	8" 1823B	8" 1843B	5		4.50	5.00
8" 1814B	8" 1824B	8" 1844B	5		4.00	5.00
PUMP SIZES			POWER SERIES	PUMP SIZE FACTOR		
				1775 RPM	1175 RPM	885 RPM
10" 1812B	10" 1822B	10" 1842B	6B	4.50	5.00	
10" 1813B	10" 1823B	10" 1843B	6B	3.25	3.75	
10" 1813C	10" 1823C	10" 1843C	6B	3.50	4.75	
10" 1814	10" 1824	10" 1844	6B	3.25	3.75	
—	8" 1826	—	7	4.50		
12" 1813B	12" 1823B	12" 1843B	7	4.75	5.50	
12" 1814A	12" 1824A	12" 1844A	7	4.00	4.50	
14" 1814	14" 1824	14" 1844	7		7.00	7.50

EXAMPLE: A 5" 1813, 5" 1823 or 5" 1843 pump operating at 1750 RPM. on a No. 4 power series with a shut-off head of 225 ft. TDH has a size factor of 3.00, a load factor of 3.35, a maximum shaft deflection at the centerline of the impeller of .0092, and a minimum bearing life of 97,000 hours @ 1750 RPM.

Tables 13 & 14

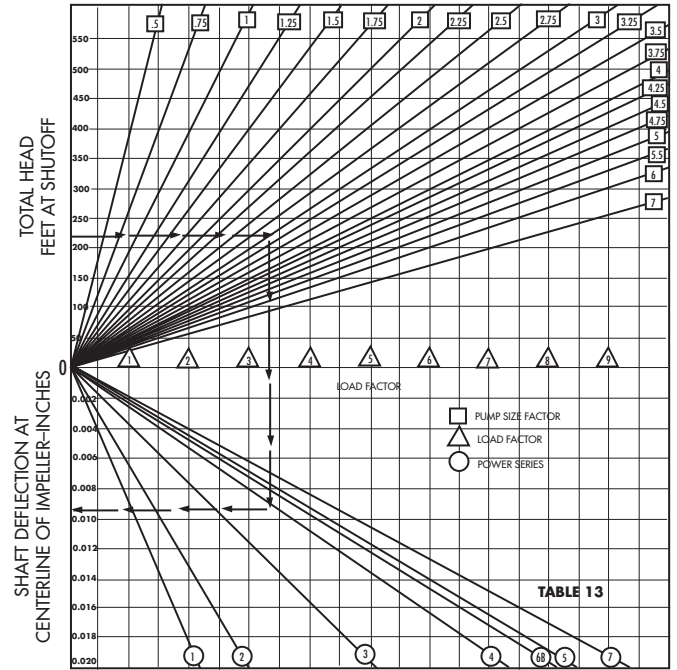

The charts reflect the worst possible conditions at pump shutoff. The effect from impeller, shaft sleeves, wearing rings and packing will reduce the amount of deflection.

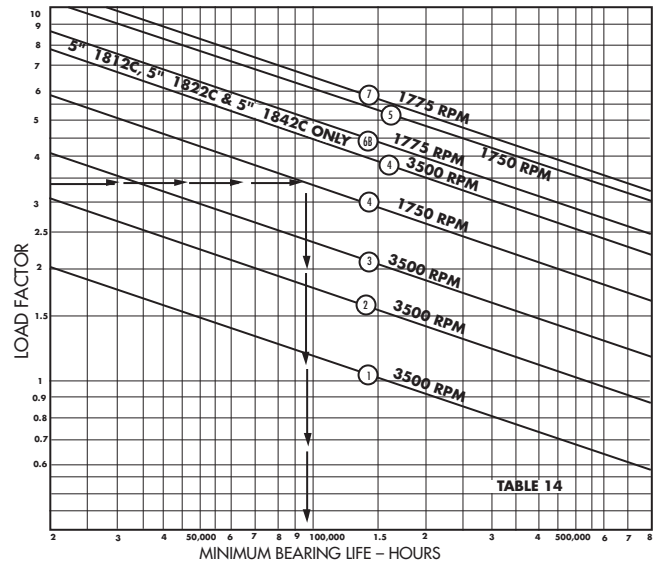
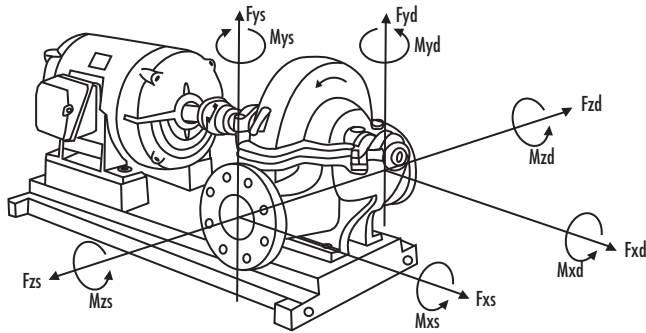

Table 12

	CHART SPEED RPM	DESIRED SPEED RPM	MULTIPLY CHART LIFE BY
SPEED (RPM) FACTORS	3500	1750	2
	3500	1150	3
	1750	1150	1.5
	1775	1175	1.5
	1775	875	2
	1175	875	1.3

QUIET PUMP SELECTION



PUMP SIZES		FORCES-LBS.			MOMENTS-FT.LBS.		
		Fx	Fy	Fz	Mx	My	Mz
2" 1823	DISCHARGE	200	250	750	250	350	300
	SUCTION	200	250	750	250	350	300
2" 1824	DISCHARGE	200	250	750	250	350	300
	SUCTION	200	250	750	250	350	300
2" 1825	DISCHARGE	200	250	750	250	350	300
	SUCTION	200	200	750	250	350	300
2-1/2" 1823B	DISCHARGE	500	550	1350	600	800	700
	SUCTION	450	550	1350	600	800	700
2-1/2" 1824	DISCHARGE	400	500	1350	600	800	700
	SUCTION	400	500	1350	600	800	700
3" 1824B	DISCHARGE	450	550	1350	600	800	700
	SUCTION	400	500	1350	600	800	700
3" 1825	DISCHARGE	400	450	1400	600	800	700
	SUCTION	350	400	1400	600	800	700
4" 1822B	DISCHARGE	450	550	1400	650	800	700
	SUCTION	400	500	1400	650	800	700
4" 1823A	DISCHARGE	250	850	750	1200	550	1400
	SUCTION	250	850	750	1200	550	1400
4" 1824	DISCHARGE	700	850	2200	1200	1600	1450
	SUCTION	650	750	2200	1200	1600	1450
4" 1825B	DISCHARGE	650	800	2200	1250	1600	1450
	SUCTION	550	700	2200	1250	1600	1450
5" 1822A	DISCHARGE	800	400	2200	500	1600	600
	SUCTION	700	350	2200	500	1600	600
5" 1823	DISCHARGE	700	850	2200	1250	1600	1450
	SUCTION	600	750	2200	1250	1600	1450
5" 1824	DISCHARGE	650	800	2250	1250	1600	1500
	SUCTION	600	750	2250	1250	1600	1500
6" 1822	DISCHARGE	800	950	2200	1250	1600	1450
	SUCTION	650	750	2200	1250	1600	1450
6" 1822HH	DISCHARGE	1150	1300	3250	2100	2800	2550
	SUCTION	950	1100	3250	2100	2800	2550
8" 1821B	DISCHARGE	750	750	2250	1000	1600	1200
	SUCTION	650	600	2250	1000	1600	1200

Values tabled are for forces and moments acting alone at the suction or discharge flange.
Combined forces and moments must be reduced so:

$$\frac{F_{xd}}{F_{xdmax}} + \frac{F_{yd}}{F_{ydmax}} + \frac{F_{zd}}{F_{zdmax}} + \frac{M_{xd}}{M_{xdmax}} + \frac{M_{yd}}{M_{ydmax}} + \frac{M_{zd}}{M_{zdmax}} + \frac{F_{xs}}{F_{xsmax}} + \frac{F_{ys}}{F_{ysmax}} + \frac{F_{zs}}{F_{zsmac}} + \frac{M_{xs}}{M_{xsmax}} + \frac{M_{ys}}{M_{ysmac}} + \frac{M_{zs}}{M_{zsmac}} \leq 1.0$$

SHAFT DEFLECTION AND BEARING LIFE

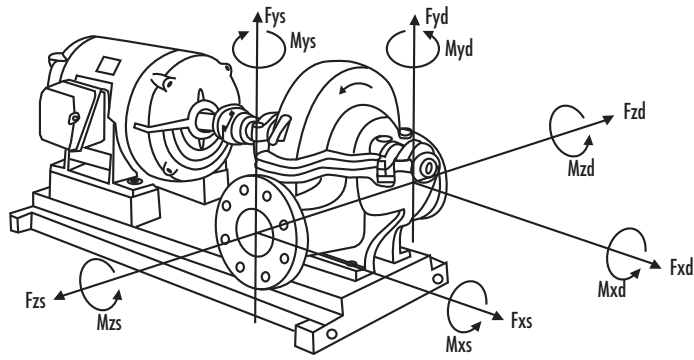

PUMP SIZES		FORCES-LBS.			MOMENTS-FT.LBS.		
		Fx	Fy	Fz	Mx	My	Mz
6" 1823HH	DISCHARGE	1150	1300	3250	2100	2800	2550
	SUCTION	950	1100	3250	2100	2800	2550
6" 1823	DISCHARGE	1150	1300	3250	2100	2800	2550
	SUCTION	950	1100	3250	2100	2800	2550
6" 1824A	DISCHARGE	1000	1200	3300	2150	2850	2600
	SUCTION	900	1050	3300	2150	2850	2600
6" 1825	DISCHARGE	1050	1250	3300	2200	2850	2650
	SUCTION	900	1100	3300	2200	2850	2650
8" 1822	DISCHARGE	950	1150	3300	2150	2850	2600
	SUCTION	900	1100	3300	2150	2850	2600
8" 1823A	DISCHARGE	950	1150	3300	2200	2850	2600
	SUCTION	900	1100	3300	2200	2850	2600
8" 1824B	DISCHARGE	950	1150	3300	2200	2850	2650
	SUCTION	900	1100	3300	2200	2850	2650
8" 1825	DISCHARGE	1650	2000	3300	4000	4350	3350
	SUCTION	1400	1700	3350	4000	4350	3350
10" 1822B	DISCHARGE	1350	1700	3350	3000	4450	4650
	SUCTION	1150	1400	3350	3000	4450	4650
10" 1823B	DISCHARGE	1300	1600	3400	3050	4500	4700
	SUCTION	1100	1350	3400	3050	4500	4700
10" 1823C	DISCHARGE	1300	1600	3400	3050	4500	4700
	SUCTION	1100	1350	3400	3050	4500	4700
10" 1824	DISCHARGE	1200	1500	3400	3050	4500	4700
	SUCTION	1000	1250	3400	3050	4500	4700
10" 1824D	DISCHARGE	1200	1500	3400	3050	4500	4700
	SUCTION	1000	1250	3400	3250	4500	4700
8" 1826	DISCHARGE	1075	1325	3350	2625	3850	3675
	SUCTION	950	1175	3350	2625	3850	3675
12" 1823B	DISCHARGE	1300	1700	3450	3250	4600	5050
	SUCTION	1000	1300	3450	3250	4600	5050
12" 1824A	DISCHARGE	1250	1650	3500	3300	4650	5100
	SUCTION	950	1250	3500	3300	4650	5100
14" 1824	DISCHARGE	1050	1450	3600	3550	4800	5500
	SUCTION	850	1150	3600	3550	4800	5500

Values tabled are for forces and moments acting alone at the suction or discharge flange.
 Combined forces and moments must be reduced so:

$$\frac{F_{xd}}{F_{xdmax}} + \frac{F_{yd}}{F_{ydmax}} + \frac{F_{zd}}{F_{zdmax}} + \frac{M_{xd}}{M_{xdmax}} + \frac{M_{yd}}{M_{ydmax}} + \frac{M_{zd}}{M_{zdmax}} + \frac{F_{xs}}{F_{xsmax}} + \frac{F_{ys}}{F_{ysmax}} + \frac{F_{zs}}{F_{zsmac}} + \frac{M_{xs}}{M_{xsmax}} + \frac{M_{ys}}{M_{ysmac}} + \frac{M_{zs}}{M_{zsmac}} \leq 1.0$$



800 Airport Road | North Aurora, Illinois 60542 | Ph: 630.859.7000 | pentair.com

All indicated Pentair trademarks and logos are property of Pentair. Third party registered and unregistered trademarks and logos are the property of their respective owners. Because we are continuously improving our products and services, Pentair reserves the right to change specifications without prior notice. Pentair is an equal opportunity employer.

©2021 Pentair. All Rights Reserved.

201812514281844104-DT (06-30-2021)