

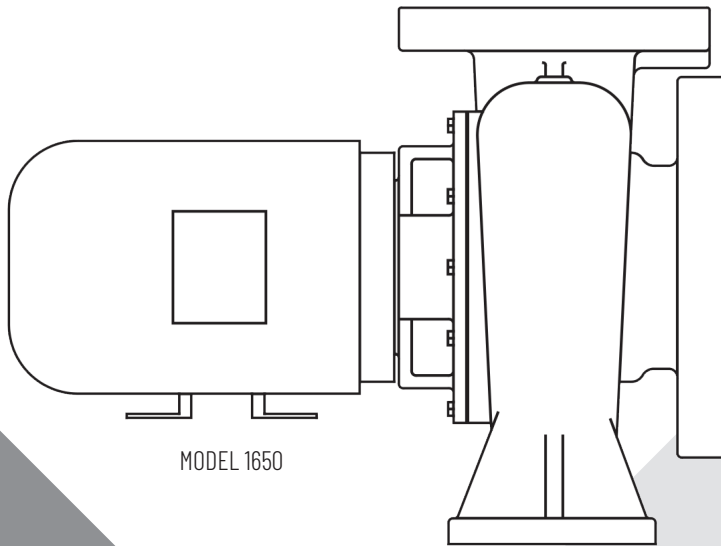

**PENTAIR FAIRBANKS NIJHUIS**

**END SUCTION PUMPS**

**1620 ♦ 1650 SERIES**



MODEL 1650

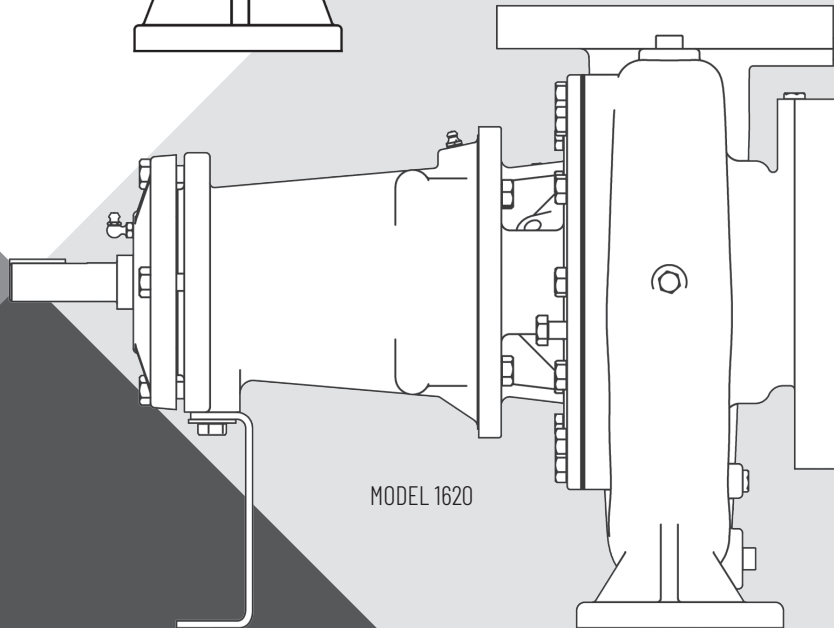

MODEL 1620

**REPAIR PARTS INDEX**

[pentair.com](http://pentair.com)

# TABLE OF CONTENTS:

---

<b>DESCRIPTION .....</b>	
Pentair Fairbanks Nijhuis® Model 1650 Exploded View and Piece Numbers .....	3
Pentair Fairbanks Nijhuis Model 1620 Exploded View and Piece Numbers .....	4
<b>PUMP SIZE.....</b>	
Pentair Fairbanks Nijhuis 1600 Series Pump Part Numbers .....	5-9
Power Frame Kits and Shaft Information.....	10
Standard Limited Warranty .....	11

**Notice to the installer:** Please make sure you provide this manual to the owner of the equipment or to the responsible party who maintains the system.

## **PENTAIR FAIRBANKS NIJHUIS MODEL 1650 CLOSE COUPLED PUMPS NOTES:**

- 1) To determine when to use **(S)**, **(L)**, or **(XL)** parts, in addition to the pump size, it is also necessary to have the close coupled motor frame.

### **MOTER FRAMES:**

Motor Frames 143-184 use **(S)** parts.  
Motor Frames 213-215 use **(S)** parts.  
Motor Frames 254-256 use **(L)** parts.  
Motor Frames 284-326 use **(L)** parts.  
Motor Frames 364-405 use **(XL)** parts.  
Motor Frames 444-449 use **(XL)** parts.

## **PENTAIR FAIRBANKS NIJHUIS MODEL 1620 FRAME MOUNTED PUMPS NOTES:**

- 1) To determine when to use **(S)**, **(L)**, or **(XL)** parts, in addition to the pump size, it is also necessary to know the Power Frame size. The Power Frame will be determined based on the pump size, speed, and motor frame.

### **POWER FRAME:**

Power Frame #1 use **(S)** parts.  
Power Frame #2 use **(L)** parts.  
Power Frame #3 use **(L)** parts.  
Power Frame #21A use **(XL)** parts.

- 2) A cross reference table for the Power Frames by pump size can be found in the 3800 Dimension Pages, reference A-01-20-300ES.

# PENTAIR FAIRBANKS NIJHUIS® MODEL 1650 EXPLODED VIEW AND PIECE NUMBERS

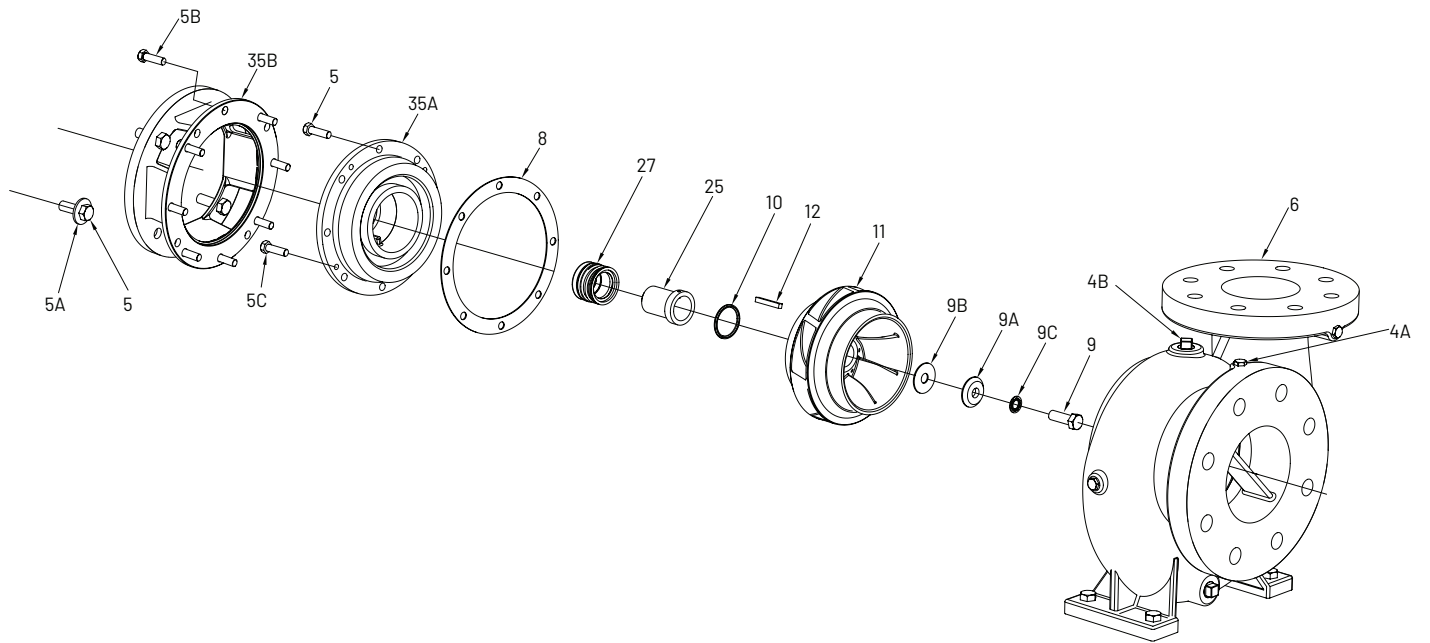

# PENTAIR FAIRBANKS NIJHUIS® MODEL 1620 EXPLODED VIEW AND PIECE NUMBERS

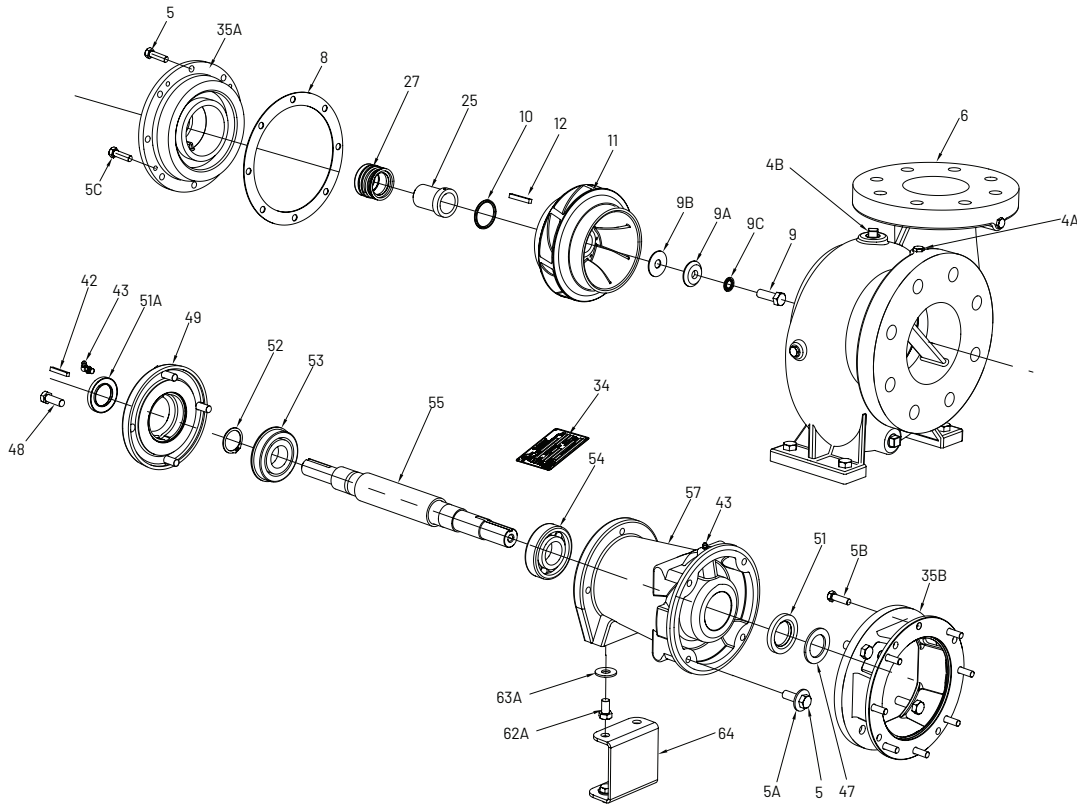

PC. NO.	DESCRIPTION
4A/B	Pipe Plug
5	Cap Screw
5A	Cap Screw Washer
5B	Cap Screw
5C	Cap Screw
6	Casing
8	Casing Gasket
9	Impeller Cap Screw
9A	Impeller Washer
9B	Impeller Gasket
9C	Impeller Seal
10	O-Ring
11	Impeller
12	Impeller Key
25	Sleeve
27	Seal
32	Cap Screw
33	Screw

PC. NO.	DESCRIPTION
34	Nameplate
35A	Seal Plate
35B	Motor Bracket
42	Key
43	Grease Fitting
47	Slinger
48	Cap Screw
49	Bearing Cap
51/A	Seal
52	Retaining Ring
53	Bearing
54	Bearing
55	Shaft
57	Frame
62A	Cap Screw
62B	Nut
63A	Washer
64	Foot Support

PENTAIR FAIRBANKS NIJHUIS RESERVES THE RIGHT TO SUBSTITUTE MATERIALS WITHOUT NOTICE.

**NOTE: WHEN ORDERING SPARE PARTS ALWAYS INCLUDE THE PUMP TYPE, SIZE, SERIAL NUMBER, AND THE PIECE NUMBER FROM THE EXPLODED VIEW IN THIS MANUAL. ORDER ALL PARTS FROM YOUR LOCAL AUTHORIZED DISTRIBUTOR OR THE FACTORY AT NORTH AURORA, ILLINOIS.**

# PENTAIR FAIRBANKS NIJHUIS® 1600 SERIES PUMP PART NUMBERS

PC. NO.	DESCRIPTION	QTY	1-1/4" 16x1	1-1/2" 16x1	2-1/2" 16x1	2"16x1A	3"16x1A	4"16x1A*
<b>6</b>	<b>CASING</b>	<b>1</b>						
	CASING (w/o Wear Ring)		180-8300-055	180-8301-055	180-8312-055	180-8304-055	180-8318-055	180-8326-055
	CASING (w/ Wear Ring) (Optional)		180-8350-055	180-8351-055	180-8362-055	180-8354-055	180-8368-055	180-8376-055
7	WEAR RING (Optional)	1	676-8100-107	676-8101-107	676-8104-107	676-8102-107	676-8106-107	676-8109-107
8	CASING GASKET	1	364-8021-603	364-8021-603	364-8021-603	364-8021-603	364-8021-603	364-8021-603
<b>11</b>	<b>IMPELLER</b>	<b>1</b>						
	IMPELLER (S)		444-8100-104	444-8101-104	444-8113-104	444-3349-104	444-3341-104	444-8131-104
	IMPELLER (L)		N/A	N/A	444-8114-104	444-3350-104	444-3342-104	444-8132-104
	IMPELLER (XL)		N/A	N/A	N/A	N/A	N/A	N/A
<b>35A</b>	<b>SEAL PLATE</b>	<b>1</b>						
	SEAL PLATE (S)		812-8084-010	812-8084-010	812-8084-010	812-8084-010	812-8084-010	812-8084-010
	SEAL PLATE (L)		N/A	N/A	812-8085-010	812-8085-010	812-8085-010	812-8085-010
	SEAL PLATE (XL)		N/A	N/A	N/A	N/A	N/A	N/A
<b>43-57</b>	<b>POWER FRAME</b>	<b>1</b>						
	POWER FRAME (S)		355-0006-644	355-0006-644	355-0006-644	355-0006-644	355-0006-644	355-0006-644
	POWER FRAME (L1)		N/A	N/A	355-0008-644	N/A	355-0008-644	355-0008-644
	POWER FRAME (L2)		N/A	N/A	N/A	N/A	355-0009-644	N/A
	POWER FRAME (XL)		N/A	N/A	N/A	N/A	N/A	N/A
<b>N/A</b>	<b>MECHANICAL SEAL KIT</b>	<b>1</b>						
	SEAL KIT (S)		476-1251-644	476-1251-644	476-1251-644	476-1251-644	476-1251-644	476-1251-644
	SEAL KIT (L)		N/A	N/A	476-1252-644	476-1252-644	476-1252-644	476-1252-644
	SEAL KIT (XL)		N/A	N/A	N/A	N/A	N/A	N/A

\* Temporarily unavailable until further notice.

SEAL KIT CONTAINS	
PC. NO.	DESCRIPTION
8	Casing Gasket
9	Impeller Cap Screw
9A	Impeller Washer
9B	Impeller Gasket
9C	Impeller Seal
10	O-Ring
12	Impeller Key
25	Sleeve
27	Mechanical Seal

# PENTAIR FAIRBANKS NIJHUIS® 1600 SERIES PUMP PART NUMBERS

PC. NO.	DESCRIPTION	QTY	5"16x1A*	1-1/4" 16x2	1-1/2" 16x4	2-1/2" 16x2	2" 16x2	3" 16x2
<b>6</b>	<b>CASING</b>	<b>1</b>						
	CASING(w/o Wear Ring)		180-8334-055	180-8647-055	180-8645-055	180-8314-055	180-8306-055	180-8320-055
	CASING(w/ Wear Ring) (Optional)		180-8384-055	180-8648-055	180-8646-055	180-8364-055	180-8356-055	180-8370-055
7	WEAR RING(Optional)	1	676-8110-107	676-8102-107	676-8102-107	676-8104-107	676-8102-107	676-8107-107
8	CASING GASKET	1	364-8021-603	364-8000-603	364-8000-603	364-8000-603	364-8000-603	364-8000-603
<b>11</b>	<b>IMPELLER</b>	<b>1</b>						
	IMPELLER(S)		444-8141-104	444-3351-104	444-3371-104	444-8115-104	444-8107-104	444-8122-104
	IMPELLER(L)		444-8142-104	444-3352-104	444-3372-104	444-8116-104	444-8108-104	444-8123-104
	IMPELLER(XL)		444-8143-104	N/A	N/A	444-8117-104	N/A	444-8124-104
<b>35A</b>	<b>SEAL PLATE</b>	<b>1</b>						
	SEAL PLATE(S)		812-8084-010	812-8086-010	812-8086-010	812-8086-010	812-8086-010	812-8086-010
	SEAL PLATE(L)		812-8085-010	812-8087-010	812-8087-010	812-8087-010	812-8087-010	812-8087-010
	SEAL PLATE(XL)		812-8096-010	N/A	N/A	812-8097-010	N/A	812-8097-010
<b>43-57</b>	<b>POWER FRAME</b>	<b>1</b>						
	POWER FRAME(S)		355-0006-644	355-0006-644	355-0006-644	355-0006-644	355-0006-644	355-0006-644
	POWER FRAME(L1)		355-0008-644	355-0008-644	355-0008-644	N/A	355-0008-644	N/A
	POWER FRAME(L2)		355-0009-644	355-0009-644	355-0009-644	355-0009-644	N/A	355-0009-644
	POWER FRAME(XL)		N/A	N/A	N/A	N/A	N/A	N/A
<b>N/A</b>	<b>MECHANICAL SEAL KIT</b>	<b>1</b>						
	SEAL KIT(S)		476-1251-644	476-1254-644	476-1254-644	476-1254-644	476-1254-644	476-1254-644
	SEAL KIT(L)		476-1252-644	476-1255-644	476-1255-644	476-1255-644	476-1255-644	476-1255-644
	SEAL KIT(XL)		476-1253-644	N/A	N/A	476-1259-644	N/A	476-1259-644

\* Temporarily unavailable until further notice.

SEAL KIT CONTAINS	
PC. NO.	DESCRIPTION
8	Casing Gasket
9	Impeller Cap Screw
9A	Impeller Washer
9B	Impeller Gasket
9C	Impeller Seal
10	O-Ring
12	Impeller Key
25	Sleeve
27	Mechanical Seal

# PENTAIR FAIRBANKS NIJHUIS® 1600 SERIES PUMP PART NUMBERS

PC. NO.	DESCRIPTION	QTY	4" 16x2	5" 16x2A	6" 16x1A*	1-1/2" 16x2	2" 16x3	3" 16x3
<b>6</b>	<b>CASING</b>	<b>1</b>						
	CASING (w/o Wear Ring)		180-8328-055	180-8336-055	180-8342-055	180-8302-055	180-8308-055	180-8322-055
	CASING (w/ Wear Ring) (Optional)		180-8378-055	180-8386-055	180-8392-055	180-8352-055	180-8358-055	180-8372-055
7	WEAR RING (Optional)	1	676-8109-107	676-8111-107	676-8113-107	676-8101-107	676-8103-107	676-8108-107
8	CASING GASKET	1	364-8000-603	364-8000-603	364-8017-603	364-8009-603	364-8009-603	364-8009-603
<b>11</b>	<b>IMPELLER</b>	<b>1</b>						
	IMPELLER(S)		444-8133-104	444-3359-104	N/A	444-8102-104	444-8109-104	444-8125-104
	IMPELLER(L)		444-8134-104	444-3360-104	444-8152-104	444-8103-104	444-8110-104	444-8126-104
	IMPELLER(XL)		444-8135-104	N/A	N/A	N/A	444-8111-104	444-8127-104
<b>35A</b>	<b>SEAL PLATE</b>	<b>1</b>						
	SEAL PLATE(S)		812-8086-010	812-8086-010	N/A	812-8089-010	812-8090-010	812-8090-010
	SEAL PLATE(L)		812-8087-010	812-8087-010	812-8088-010	812-8091-010	812-8092-010	812-8092-010
	SEAL PLATE(XL)		812-8097-010	N/A	N/A	N/A	812-8102-010	812-8102-010
<b>43-57</b>	<b>POWER FRAME</b>	<b>1</b>						
	POWER FRAME(S)		355-0006-644	355-0006-644	N/A	355-0006-644	355-0006-644	355-0006-644
	POWER FRAME(L1)		355-0008-644	355-0008-644	355-0008-644	355-0008-644	N/A	N/A
	POWER FRAME(L2)		N/A	355-0009-644	N/A	N/A	355-0009-644	355-0009-644
	POWER FRAME(XL)		N/A	N/A	N/A	N/A	N/A	N/A
<b>N/A</b>	<b>MECHANICAL SEAL KIT</b>	<b>1</b>						
	SEAL KIT (S)		476-1254-644	476-1254-644	N/A	476-1257-644	476-1257-644	476-1257-644
	SEAL KIT (L)		476-1255-644	476-1255-644	476-1256-644	476-1258-644	476-1258-644	476-1258-644
	SEAL KIT (XL)		476-1259-644	N/A	N/A	N/A	476-1260-644	476-1260-644

\* Temporarily unavailable until further notice.

SEAL KIT CONTAINS	
PC. NO.	DESCRIPTION
8	Casing Gasket
9	Impeller Cap Screw
9A	Impeller Washer
9B	Impeller Gasket
9C	Impeller Seal
10	O-Ring
12	Impeller Key
25	Sleeve
27	Mechanical Seal

# PENTAIR FAIRBANKS NIJHUIS® 1600 SERIES PUMP PART NUMBERS

PC. NO.	DESCRIPTION	QTY	4" 16x3A	5" 16x3	6" 16x2A	1-1/2" 16x3	2-1/2" 16x3	2" 16x4
<b>6</b>	<b>CASING</b>	<b>1</b>						
	CASING (w/o Wear Ring)		180-8330-055	180-8338-055	180-8344-055	180-8303-055	180-8316-055	180-8310-055
	CASING (w/ Wear Ring) (Optional)		180-8380-055	180-8388-055	180-8394-055	180-8353-055	180-8366-055	180-8360-055
7	WEAR RING (Optional)	1	676-8116-107	676-8112-107	676-8114-107	676-8101-107	676-8105-107	676-8103-107
8	CASING GASKET	1	364-8009-603	364-8009-603	364-8009-603	364-8010-603	364-8011-603	364-8011-603
<b>11</b>	<b>IMPELLER</b>	<b>1</b>						
	IMPELLER (S)		444-3338-104	N/A	N/A	444-8104-104	444-8118-104	N/A
	IMPELLER (L)		444-3339-104	444-8148-104	444-3335-104	N/A	444-8119-104	444-8112-104
	IMPELLER (XL)		444-3340-104	N/A	N/A	N/A	N/A	N/A
<b>35A</b>	<b>SEAL PLATE</b>	<b>1</b>						
	SEAL PLATE (S)		812-8090-010	N/A	N/A	812-8093-010	812-8094-010	N/A
	SEAL PLATE (L)		812-8092-010	812-8092-010	812-8092-010	N/A	812-8095-010	812-8095-010
	SEAL PLATE (XL)		812-8102-010	N/A	N/A	N/A	N/A	N/A
<b>43-57</b>	<b>POWER FRAME</b>	<b>1</b>						
	POWER FRAME (S)		355-0006-644	N/A	N/A	355-0006-644	N/A	N/A
	POWER FRAME (L1)		355-0008-644	355-0008-644	N/A	N/A	N/A	N/A
	POWER FRAME (L2)		355-0009-644	355-0009-644	355-0009-644	N/A	355-0009-644	355-0009-644
	POWER FRAME (XL)		355-0300-644	N/A	N/A	N/A	N/A	N/A
<b>N/A</b>	<b>MECHANICAL SEAL KIT</b>	<b>1</b>						
	SEAL KIT (S)		476-1257-644	N/A	N/A	476-1261-644	476-1262-644	N/A
	SEAL KIT (L)		476-1258-644	476-1258-644	476-1258-644	N/A	476-1263-644	476-1263-644
	SEAL KIT (XL)		476-1260-644	N/A	N/A	N/A	N/A	N/A

## SEAL KIT CONTAINS

PC. NO.	DESCRIPTION
8	Casing Gasket
9	Impeller Cap Screw
9A	Impeller Washer
9B	Impeller Gasket
9C	Impeller Seal
10	O-Ring
12	Impeller Key
25	Sleeve
27	Mechanical Seal



# PENTAIR FAIRBANKS NIJHUIS® 1600 SERIES PUMP PART NUMBERS

PC. NO.	DESCRIPTION	QTY	3" 16x4	4" 16x4	5" 16x4	6" 16x3	8" 16x2
<b>6</b>	<b>CASING</b>	<b>1</b>					
	CASING (w/o Wear Ring)		180-8324-055	180-8332-055	180-8340-055	180-8346-055	180-8348-055
	CASING (w/ Wear Ring) (Optional)		180-8374-055	180-8382-055	180-8390-055	180-8396-055	180-8398-055
7	WEAR RING (Optional)	1	676-8108-107	676-8109-107	676-8112-107	676-8114-107	676-8115-107
8	CASING GASKET	1	364-8011-603	364-8011-603	364-8011-603	364-8011-603	364-8011-603
<b>11</b>	<b>IMPELLER</b>	<b>1</b>					
	IMPELLER(S)		N/A	N/A	N/A	N/A	N/A
	IMPELLER(L)		444-8129-104	444-8139-104	444-8150-104	444-8155-104	444-8157-104
	IMPELLER(XL)		N/A	444-8140-104	N/A	444-8156-104	444-8158-104
<b>35A</b>	<b>SEAL PLATE</b>	<b>1</b>					
	SEAL PLATE(S)		N/A	N/A	N/A	N/A	N/A
	SEAL PLATE(L)		812-8095-010	812-8095-010	812-8095-010	812-8101-010	812-8101-010
	SEAL PLATE(XL)		N/A	812-8098-010	N/A	812-8099-010	812-8099-010
<b>43-57</b>	<b>POWER FRAME</b>	<b>1</b>					
	POWER FRAME(S)		N/A	N/A	N/A	N/A	N/A
	POWER FRAME(L1)		355-0008-644	N/A	N/A	N/A	N/A
	POWER FRAME(L2)		355-0009-644	355-0009-644	355-0009-644	N/A	N/A
	POWER FRAME(XL)		N/A	355-0300-644	N/A	355-0300-644	355-0300-644
<b>N/A</b>	<b>MECHANICAL SEAL KIT</b>	<b>1</b>					
	SEAL KIT(S)		N/A	N/A	N/A	N/A	N/A
	SEAL KIT(L)		476-1263-644	476-1263-644	476-1263-644	476-1263-644	476-1263-644
	SEAL KIT(XL)		N/A	476-1264-644	N/A	476-1264-644	476-1264-644

## SEAL KIT CONTAINS

PC. NO.	DESCRIPTION
8	Casing Gasket
9	Impeller Cap Screw
9A	Impeller Washer
9B	Impeller Gasket
9C	Impeller Seal
10	O-Ring
12	Impeller Key
25	Sleeve
27	Mechanical Seal

## POWER FRAME KITS AND SHAFT INFORMATION

PC. NO.	DESCRIPTION	QTY	PF #1(S)	PF #2 (L1)	PF #3 (L2)	PF #21A (XL)
55	PUMP SHAFT	1	728-0121-063	728-0122-063	728-0123-063	728-7500-063
25	SHAFT SLEEVE	1	756-0077-208	756-0078-208	756-0078-208	756-0830-208
N/A	MECHANICAL SEAL KIT <sup>1</sup>	1	476-1265-644	476-1266-644	476-1266-644	476-1267-644
<b>N/A</b>	<b>POWER FRAME REPAIR KIT</b>	<b>1</b>				
	GREASE LUBE		476-0621-644	476-0622-644	476-0623-644	476-0627-644
	OIL LUBE		476-0624-644	476-0625-644	476-0626-644	476-0627-644

<sup>1</sup> These seal kits differ from those on the previous pages because they contain casing gaskets for all available pump sizes.

SEAL KIT CONTAINS		POWER FRAME REPAIR KIT CONTAINS	
PC. NO.	DESCRIPTION	PC. NO.	DESCRIPTION
8	Casing Gasket (All Pump Sizes)	47A	Slinger
9	Impeller Cap Screw	50	Gasket
9A	Impeller Washer	51	Seal
9B	Impeller Gasket	51A	Seal
9C	Impeller Seal	52	Retaining Ring
10	O-Ring	53	Bearing
12	Impeller Key	54	Bearing
25	Sleeve		
27	Mechanical Seal		

# STANDARD LIMITED WARRANTY

---

## LIMITED WARRANTY

Seller warrants equipment (and its component parts) of its own manufacture against defects in materials and workmanship under normal use and service for one (1) year from the date of installation or start-up, or for eighteen (18) months after the date of shipment, whichever occurs first. Seller warrants 1600 series end suction pump models for a period of five (5) years from the date of installation or start-up, or for sixty (60) months after the date of shipment, whichever comes first. Seller does not warrant accessories or components that are not manufactured by Seller; however, to the extent possible, Seller agrees to assign to Buyer its rights under the original manufacturer's warranty, without recourse to Seller. Buyer must give Seller notice in writing of any alleged defect covered by this warranty (together with all identifying details, including the serial number, the type of equipment, and the date of purchase) within thirty (30) days of the discovery of such defect during the warranty period. No claim made more than 30 days after the expiration of the warranty period shall be valid. Guarantees of performance and warranties are based on the use of original equipment manufactured (OEM) replacement parts. Seller assumes no responsibility or liability if alterations, non-authorized design modifications and/or non-OEM replacement parts are incorporated. If requested by Seller, any equipment (or its component parts) must be promptly returned to Seller prior to any attempted repair, or sent to an authorized service station designated by Seller, and Buyer shall prepay all shipping expenses. Seller shall not be liable for any loss or damage to goods in transit, nor will any warranty claim be valid unless the returned goods are received intact and undamaged as a result of shipment. Repaired or replaced material returned to customer will be shipped F.O.B., Seller's factory. Seller will not give Buyer credit for parts or equipment returned to Seller, and will not accept delivery of any such parts or equipment, unless Buyer has obtained Seller's approval in writing. The warranty extends to repaired or replaced parts of Seller's manufacture for ninety (90) days or for the remainder of the original warranty period applicable to the equipment or parts being repaired or replaced, whichever is greater. This warranty applies to the repaired or replaced part and is not extended to the product or any other component of the product being repaired. Repair parts of its own manufacture sold after the original warranty period are warranted for a period of one (1) year from shipment against defects in materials and workmanship under normal use and service. This warranty applies to the replacement part only and is not extended to the product or any other component of the product being repaired. Seller may substitute new equipment or improve part(s) of any equipment judged defective without further liability. All repairs or services performed by Seller, which are not covered by this warranty, will be charged in accordance with Seller's standard prices then in effect.

**THIS WARRANTY IS THE SOLE WARRANTY OF SELLER AND SELLER HEREBY EXPRESSLY DISCLAIMS AND BUYER WAIVES ALL OTHER WARRANTIES EXPRESSED, IMPLIED IN LAW OR IMPLIED IN FACT, INCLUDING ANY WARRANTIES OF MERCHANTABILITY OR FITNESS FOR A PARTICULAR PURPOSE.** Seller's sole obligation under this warranty shall be, at its option, to repair or replace any equipment (or its component parts) that has a defect covered by this warranty, or to refund the purchase price of such equipment or part. Under the terms of this warranty, Seller shall not be liable for (a) consequential, collateral, special or liquidated losses or damages; (b) equipment conditions caused by normal wear and tear, abnormal conditions of use, accident, neglect, or misuse of said equipment; (c) the expense of, and loss or damage caused by, repairs or alterations made by anyone other than the Seller; (d) damage caused by abrasive materials, chemicals, scale deposits, corrosion, lightning, improper voltage, mishandling, or other similar conditions; (e) any loss, damage, or expense relating to or resulting from installation, removal or reinstallation of equipment; (f) any labor costs or charges incurred in repairing or replacing defective equipment or parts, including the cost of reinstalling parts that are repaired or replaced by Seller; (g) any expense of shipment of equipment or repaired or replacement parts; or (h) any other loss, damage, or expense of any nature.

The above warranty shall not apply to any equipment that may be separately covered by any alternate or special warranties.

**PERFORMANCE:** In the absence of Certified Pump Performance Tests, equipment performance is not warranted or guaranteed. Performance curves and other information submitted to Buyer are approximate, and no warranty or guarantee shall be deemed to arise as a result of such submittal. All testing shall be done in accordance with Seller's standard policy under Hydraulic Institute procedures.

**LIABILITY LIMITATIONS:** Under no circumstances shall the Seller have any liability under the Order or otherwise for liquidated damages or for collateral, consequential, or special damages or for loss of profits, or for actual losses or for loss of production or progress of construction, regardless of the cause of such damages or losses. In any event, Seller's aggregate total liability under the Order or otherwise shall not exceed the contract price.

**ACTS OF GOD:** Seller shall in no event be liable for delays in delivery of the equipment or other failures to perform caused by fires, acts of God, strikes, labor difficulties, acts of governmental or military authorities, delays in transportation or procuring materials, or causes of any kind beyond Seller's control.

**COMPLIANCE WITH LAW:** Seller agrees to comply with all United States laws and regulations applicable to the manufacturing of the subject equipment. Such compliance shall include: The Fair Labor Standards Acts of 1938, as amended; Equal Employment Opportunity clauses of Executive Order 11246, as amended; Occupational Safety and Health Act of 1970 and the standards promulgated thereunder, if applicable. Since compliance with the various Federal, State and Local laws and regulations concerning occupational health and safety, pollution, or local codes are affected by the use, installation, and operation of the equipment and other matters over which Seller has no control, Seller assumes no responsibility for compliance with those laws and regulations, whether by way of indemnity, warranty, or otherwise. It is incumbent upon the Buyer to specify equipment that complies with local codes and ordinances.

800 Airport Road  
North Aurora, Illinois 60542  
630-859-7000



800 Airport Road | North Aurora, Illinois 60542 | Ph: 630.859.7000 | [pentair.com](http://pentair.com)

All indicated Pentair trademarks and logos are property of Pentair. Third party registered and unregistered trademarks and logos are the property of their respective owners. Because we are continuously improving our products and services, Pentair reserves the right to change specifications without prior notice. Pentair is an equal opportunity employer.

FM-03-542 (02-15-21) ©2021 Pentair. All Rights Reserved.