



FLECK NXT
OWNER'S MANUAL



FEATURES OF YOUR WATER CONDITIONING SYSTEM

Congratulations on the purchase of your new water conditioning system featuring the NXT electronic controller.

You will have peace of mind knowing your system will bring you years of treated water use and enjoyment.

Your water conditioning system helps you:

Eliminate:

- Stains
- Scale Deposits
- Soap Scum
- Clogged Plumbing
- Dissolved Minerals

Enjoy:

- Longer lasting appliances (up to 30% longer)
- Less detergent / soap / cleanser use
- Greater lathering of soap
- Cleaner dishes, towels, and linens
- Softer skin



MANUAL OVERVIEW

How To Use This Manual

This owner's manual is designed to provide the equipment owner with instructions on performing routine care and maintenance of the water softener or filter valve and control packaged with this manual.

This manual does not include instructions regarding installation, setup, service, or troubleshooting of the valve, control, or other components of a water conditioning system. Please contact your local water treatment professional with questions or concerns about the operation or performance of your water conditioning system.

Icons That Appear In This Manual

⚠ WARNING: Failure to follow this instruction can result in personal injury or damage to the equipment.

NOTE: This will make the process easier if followed.

General Warnings

⚠ WARNING: There are no user-serviceable parts in the AC adapter, motor, or controller. Do not attempt to remove or repair individual components.

⚠ WARNING: Use only the power transformer supplied with this water conditioning system.

⚠ WARNING: The power outlet must be grounded and always on. If it is necessary to disconnect power, unplug the AC adapter from its power source.

⚠ WARNING: Only fill the brine tank with salt designed for water softening.

⚠ WARNING: Ambient temperature surrounding the system should be between 35°F (1°C) and 120°F (49°C).

⚠ WARNING: Unless equipped with hot water components water temperature flowing through the system should be between 35°F (1°C) and 100°F (38°C).

California Proposition 65 Warning

⚠ WARNING: This product contains chemicals known to the State of California to cause cancer or birth defects or other reproductive harm.

Job No. _____
 Model No. _____
 Water Test _____
 Capacity Per Unit _____ Maximum _____ Per Regeneration
 Mineral Tank Size _____ Diameter _____ Height
 Brine Tank Size & Salt Setting per Regeneration _____

Control Valve Specifications

Day/Time of Regeneration: _____
 Drain Line Flow Control: _____ gpm
 Brine Refill Rate: _____ gpm
 Injector Size: _____ gpm
 Meter Gallon Setting _____ Gallons

FEATURES OF THE NXT CONTROLLER

- On-screen multilingual support: English, French, German, Portuguese, Spanish
- Time of day super capacitor backup for power loss
- Two-line/ 16 character full text LCD backlit display
- Shift button allows digit selecting
- LED Status indicator
 - Blue: In service
 - Flashing Blue: Regeneration Queued
 - Green: Regeneration
 - Flashing Green: Standby
 - Red: Error with codes

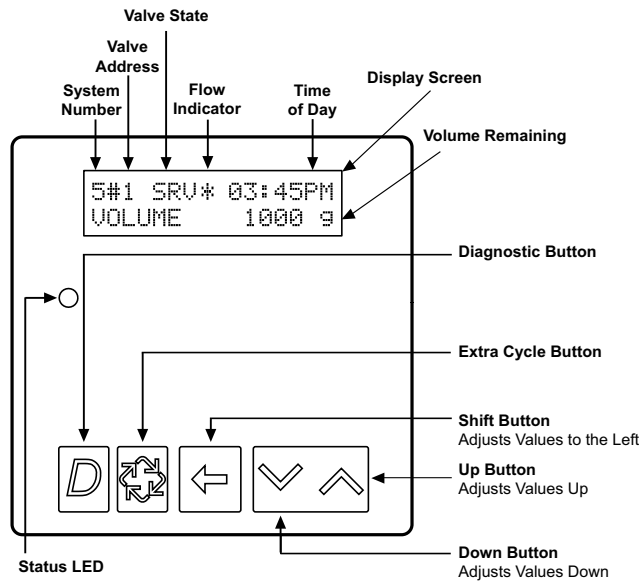

SETTING TIME OF DAY AND INITIATING A MANUAL REGENERATION

Setting the Time of Day

1. Press and hold either the Up or Down button for two seconds.
2. Press the Shift button to select the digit you want to modify.
3. Press the Up or Down button to adjust the value.
4. Press the Extra Cycle button to return to the normal display screen, or wait for a five second timeout.

Queueing a Regeneration

1. Press the Extra Cycle button. The Display Screen will show "RGQ" as the valve status, indicating that a regeneration is scheduled..
2. To cancel a queued regeneration, press the Extra Cycle button.

Regenerating Immediately

Press and hold the Extra Cycle button for five seconds.

USER PROGRAMMING

⚠ WARNING: Before entering User Programming, please contact your local water treatment professional. For complete programming options, refer to Master Programming Flow Chart.

Enter User Mode

- Press and hold the Up or Down buttons for 5 seconds.

Set Language Option

- Press Up or Down to select language.
- Press the Extra Cycle button to proceed to the next step.

Set Feed Water Hardness

Press the Shift, Up, and Down buttons to move the cursor and change the value of the numbers. Press the Extra Cycle button to proceed to the next step.

NOTE: Only displayed when a metered option is chosen under System Type.

Set Regeneration Day Override

- To turn On and set the days, press the Down button.
- Press the Shift, Up, and Down buttons to move the cursor and change the value of the numbers.
- Press the Extra Cycle button to proceed to the next step.

Regeneration Time

- Press the Shift, Up, and Down buttons to move the cursor and change the value of the numbers.
- Press the Extra Cycle button to end user programming mode.

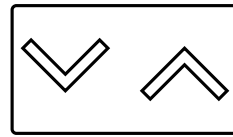

Figure 1 Up and Down Buttons



Figure 2 Shift Button



Figure 3 Extra Cycle Button

SELECT LANGUAGE
ENGLISH

Figure 4 Select Language Screen

FEED WATER
HARDNESS: 015 GPG

Figure 5 Feed Water Hardness Screen

REGENERATION DAY
OVERRIDE: 01 DAYS

Figure 6 Regeneration Day Override Screen

REGENERATION
TIME: 02:00AM

Figure 7 Regeneration Time Screen

BYPASSING THE WATER CONDITIONING SYSTEM

A bypass should be installed on all water conditioning systems. A bypass isolates the conditioner from the water system and allows unconditioned water to be used while the conditioner is undergoing service or maintenance procedures or if the conditioner is experiencing performance issues. Figures 8 and 9 show the most common bypass methods.

Knob Style Plastic Bypass Valve

This type of bypass is located directly behind the conditioner valve on top of the media tank. To bypass the conditioner system using this type of bypass, turn both of the knobs on the sides of the bypass clockwise until the holes in the knobs are facing up as shown in Figure 8 Knob Style Plastic Bypass Valve.

To return the conditioner system to regular service, turn both of the knobs on the bypass counter-clockwise back to their original positions.

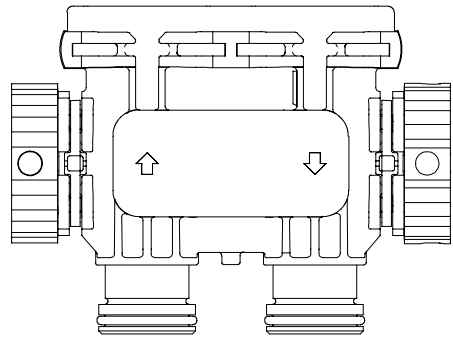

Figure 8 Knob Style Plastic Bypass Valve

Manual Bypass

This type of bypass system is plumbed into the water system, and generally consists of three valves: one on the inflow line going into the conditioning system, one on the outflow line coming out of the conditioning system, and one on the bypass line connecting the inflow and outflow lines (See Figure 9 Manual Bypass).

To bypass the conditioner system using this type of bypass (following Figure 9 Manual Bypass), open Valve 2 and close Valves 1 and 3.

To return the conditioner system to regular service, open Valves 1 and 3 and close Valve 2.

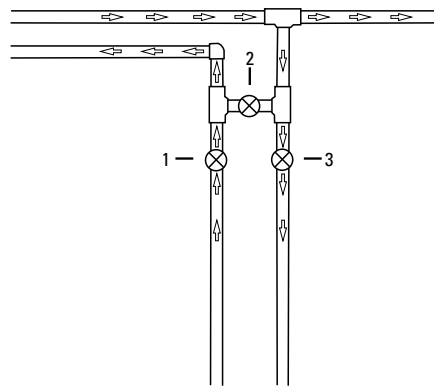

Figure 9 Manual Bypass

CARE AND USE OF YOUR BRINE TANK (IF EQUIPPED)

Each time the softener regenerates, salty water (brine) is needed to recondition the media in the water tank. The brine is pulled from the salt tank at a controlled amount. If the salt tank does not contain enough salt, the brine is weak, the media will not fully recondition and untreated water will pass through. To ensure the highest level of performance of your water conditioning system, please observe the following:

- Keep the brine tank filled with salt at all times. The salt level should always be higher than the water level in the brine tank.
- Only use sodium chloride salt designed for water softeners. Other types of salt (rock or snow melting) may contain dirt and chemicals that will affect the quality of your water and the performance of your water softener.
- Keep the brine tank covered.
- Empty and clean the tank when enough debris accumulates interfering with operation of system.
- Water filters do not have brine tanks

CONTROL OPERATION DURING A POWER FAILURE

The NXT includes integral power backup. In the event of power failure, the control shifts into a power-saving mode. The control stops monitoring water usage, and the display and motor shut down, but it continues to keep track of the time and day for a minimum of 8 hours. The system configuration settings are stored in a non-volatile memory and are stored indefinitely with or without line power.

If power fails while the unit is in regeneration, the control will save the current valve position before it shuts down. When power is restored, the control will resume the regeneration cycle from the point where power failed. Note that if power fails during a regeneration cycle, the valve will remain in its current position until power is restored. The valve system should include all required safety components to prevent overflows resulting from a power failure during regeneration.

NOTE: After power is restored following a power failure, time of day will flash to indicate a power interruption. Press the Extra Cycle button to resume normal operation.

The control will not start a new regeneration cycle without line power. If the valve misses a scheduled regeneration due to a power failure, it will queue a regeneration. Once power is restored, the control will initiate a regeneration cycle the next time that the Time of Day equals the programmed regeneration time. Typically, this means that the valve will regenerate one day after it was originally scheduled. If the treated water output is important and power interruptions are expected, the system should be setup with a sufficient reserve capacity to compensate for regeneration delays.

TROUBLESHOOTING

Detected Errors

If a communication error is detected, an Error Screen will alternate with the main (time of day) screen every few seconds.

- All units In Service remain in the In Service position.
- All units in Standby go to In Service.
- Any unit in Regeneration when the error occurs completes Regeneration and goes to In Service.
- No units are allowed to start a Regeneration Cycle while the error condition exists, unless they are manually forced into Regeneration.
- When an error is corrected and the error no longer displays (it may take several seconds for all of the units in a system to stop displaying the error message), the system returns to normal operation.

NOTE: During the error condition the control continues to monitor the flow meter and update the volume remaining. Once the error condition is corrected all units return to the operating status they were in prior to the error. Regeneration queue is rebuilt according to the normal system operation. Or, if more than one unit has been queued for regeneration, then the queue is rebuilt according to which one communicates first.

Message Displayed	Correction
Flashing time	Power outage. Press any button to clear flashing display. See SETTING TIME OF DAY AND INITIATING A MANUAL REGENERATION to reset time if needed. See CONTROL OPERATION DURING A POWER FAILURE for more information.
Detected Error = Matching Address	Contact your local water treatment professional.
Detected Error = Program Mismatch	
Detected Error = No Message #X	
Detected Error = E2 Reset Unit	
Test Mode	
Black Squares on screen	
INI on screen for more than 2 minutes	
CHG on screen for more than 2 minutes	

Common Issues

Problem	Solution
Control valve fails to regenerate	Check for power outage and verify unit is plugged in. Attempt to perform a manual regeneration. See SETTING TIME OF DAY AND INITIATING A MANUAL REGENERATION. If problem still exists, contact your local water treatment professional.
Water does not feel or appear soft	Check salt in brine tank and ensure salt level is above water level. If problem still exists, contact your local water treatment professional.
Unit uses too much salt	Contact your local water treatment professional.
Loss of water pressure	
Iron in conditioned water	
Excessive water in brine tank	
Other problems with the water softener	
Power Outage	See CONTROL OPERATION DURING A POWER FAILURE for more information.

DEALER STAMP

For product warranties, complete service manuals, and additional resources visit: waterpurification.pentair.com



All Pentair trademarks and logos are owned by Pentair, Inc. or its affiliates. All other registered and unregistered trademarks and logos are the property of their respective owners. Because we are continuously improving our products and services, Pentair reserves the right to change specifications without prior notice.

Pentair is an equal opportunity employer.

44052 REV A JA16 © 2016 Pentair Residential Filtration, LLC All Rights Reserved.