

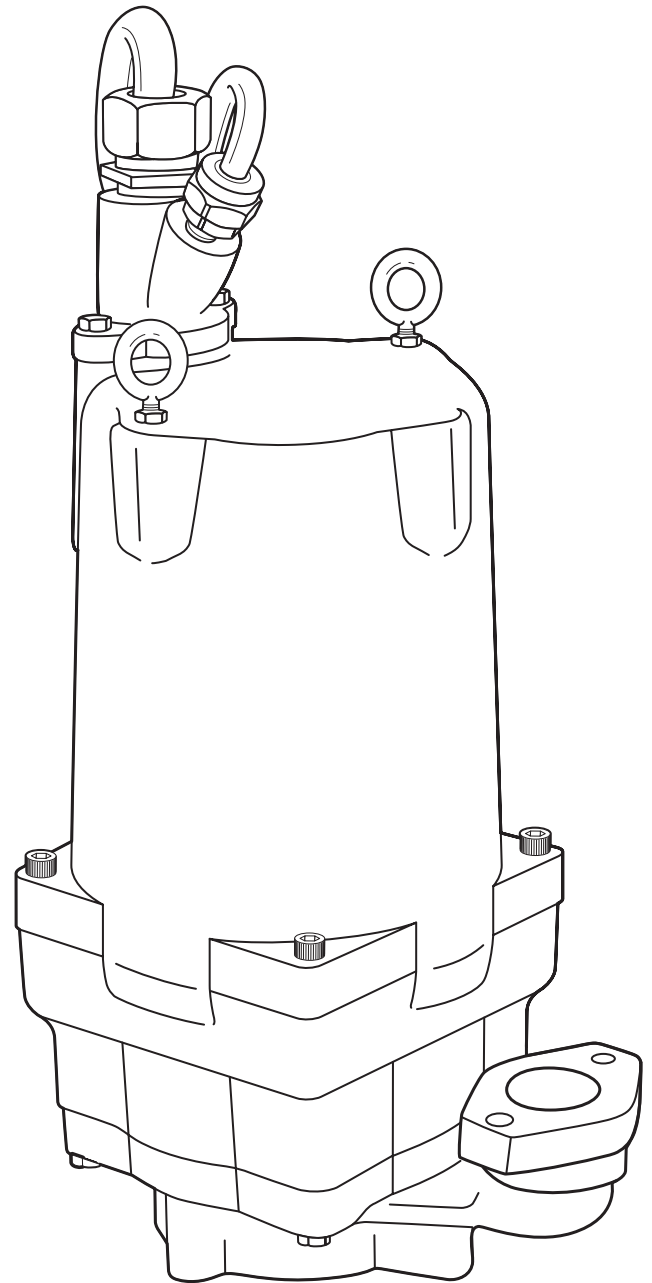

HYDROMATIC®



MODEL HPGX200

(Class I, Division 1, Groups C & D): FM

HAZARDOUS LOCATION SUBMERSIBLE GRINDER PUMP

INSTALLATION AND SERVICE MANUAL



NOTE! To the installer: Please make sure you provide this manual to the owner of the equipment or to the responsible party who maintains the system.

General Information

Attention:

This manual contains important information for the safe use of this product. Read this manual completely before using this product and refer to it often for continued safe product use. **DO NOT THROW AWAY OR LOSE THIS MANUAL.**

Pump Warning

IMPORTANT: Read all directions before replacing any parts.

WARNING: Before handling these pumps and controls, always disconnect the power first.

Do not smoke or use sparkable electrical devices or flames in a septic (gaseous) or possible septic sump.

Application:

These pumps are designed for on-site residential sewage discharge applications with a pH ranging from 6 to 9, specific gravities from 0.9 to 1.1, viscosities ranging from 28 to 35 S.S.U., and temperatures up to 140 degrees Fahrenheit.

Receiving Pump:

Pump should be checked on arrival for possible concealed shipping damage. Any damage should be reported immediately to delivery carrier. Claims for damage must originate at the receiving end. Claims for shipping damage cannot be processed by the factory.

Codes:

All local wiring codes must be observed. Consult the local inspector before installation to avoid delays that can occur due to rejection after job is finished.

CALIFORNIA PROPOSITION 65 WARNING:

▲ WARNING This product and related accessories contain chemicals known to the State of California to cause cancer, birth defects or other reproductive harm.

Pumps Not Operating or in Storage:

Pumps with carbon ceramic seals must have impellers manually rotated (6 revolutions) after setting non-operational for 3 months or longer and prior to electrical start-up.

Seal Failure Probes:

All hazardous location submersible pumps have two factory-installed moisture detectors (seal failure probes). They are in a normally open series circuit in the seal chamber. Under normal operating conditions the circuit remains open. If the lower seal leaks and moisture enters this chamber, the moisture would settle to the bottom of the chamber and will complete the circuit between the moisture detectors.

This circuit must be connected to a sensing unit and signaling device. This is supplied in a Hydromatic® control panel.

NOTE: Failure to install such a device negates all warranties by Hydromatic.

Heat Sensors:

All motors in this family have heat sensors on or embedded in the motor winding to detect excessive heat. This prevents damage to the motor. If the sensor trips due to excessive winding temperature, the starter in the panel breaks power to the pump. Once the sensor resets, the starter is to be reset (automatic for FM) for continued operation of the pump. This circuitry is supplied in a Hydromatic control

panel. The sensors are set to trip at 120 degrees Celsius.

NOTE: Failure to install such circuitry would negate FM approval and all warranties by Hydromatic.

Power Cords:

The power cord and heat sensor seal failure cord are potted into the connection box cap. The cords must not be spliced.

NOTE: Each cable has a green lead. This is the ground wire and must be grounded properly per NEC and/or local codes. During normal maintenance procedures power cords should be inspected for abnormal wear and replaced accordingly.

Overload Heaters:

If the Hydromatic electrical panel is not used, starters with 3-leg overload relay must be supplied on 3-phase pumps. Each leg is to have an identical heater sized in accordance with the nameplate amps on the motor housing. The amp draw on these submersible motors is slightly higher than a corresponding horsepower surface motor, so heaters must be sized by the nameplate rating.

Single-phase pumps with capacitor start have a run and a start winding, each drawing a different current. To adequately protect these windings with the appropriate heaters, consult the factory.

NOTE: Red lead is always the start winding of the single phase pump.

Pump Installation

Installing Pump in Sump:

Before installing pump in sump, lay it on its side and rotate impeller. Impeller may be slightly stuck due to factory test water so

it must be broken loose with a small bar or screwdriver in edge of vanes. The impeller should turn freely. Do not connect the power until after this test.

Clean all trash and sticks from sump and connect pump to piping. A check valve must be installed on each pump.

Location:

If pumps are installed in an existing basin or concrete sump, the piping can either be connected permanently or rails and brackets can be furnished for mounting to walls of basin. In either case, be sure the Hydromatic® solids handling ball check valve is used

SENSOR LEADS	
COLOR	PURPOSE
Red	Seal Failure
Pink	Seal Failure
White	Heat Sensor
Black	Heat Sensor
Green	Ground

MOTOR LEADS

208 - 230V SINGLE PHASE

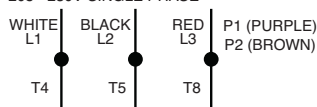

230V (DUAL VOLTAGE) THREE PHASE

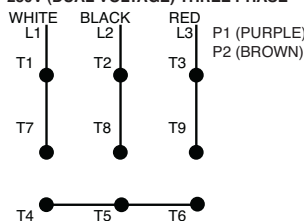

200V AND 575V THREE PHASE

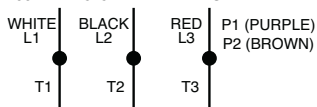

460V (DUAL VOLTAGE) THREE PHASE

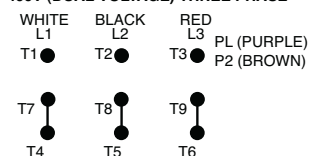

and that the pumps are submerged in a vertical position. The complete factory-built packaged system is recommended for the most satisfactory and economical installation.

Making Electrical Connections:

All electrical wiring must be in accordance with local code, and only qualified electricians should make the installations. All wires should be checked for shorts to ground with an ohmmeter or Megger after the connections are made. This is important, as one grounded wire can cause considerable trouble.

IMPORTANT: If equipment is not properly wired and protected as recommended, Hydromatic warranty is void.

Caution: The 230 volt 3 phase pump has a dual marked nameplate. Voltage may be rewired by the manufacturer or a Class I Div 1 equipment qualified electrician. Once the voltage is changed, the factory cord tag indicating 230 volt 3 phase must be removed.

For record keeping purposes, we suggest the pump be marked externally with the new voltage and qualified personnel that performed the change. Pumps shipped from the factory as 460 volt 3 phase cannot be rewired to any other voltage.

To Re-wire the pump from 230V to 460V 3 phase:

Only a 230V pump from the factory is considered dual voltage, a cord label clearly states the factory wound voltage.

Remove bolts securing cord assembly then raise the cord cap assembly enough to slip a prying instrument on opposite sides between the cord cap casting and the junction box. Take care to not damage the o-ring or the machined surfaces of the castings. Doing so could void FM agency

certifications. While prying evenly on both sides; separate the cord cap casting from the motor housing, the assembly is airtight and will have a vacuum effect when disassembling. Once separated, the cord cap can be inverted and rotated to the outside of the pump assembly, and a bolt can be re-used to secure the upside down cord cap to the motor housing for ease of rewiring.

Refer to the wiring diagram within this manual for wiring details. Once all electrical connections are finished and secure (a crimped electrical connector is best to prevent issues due to vibration if required), the cord cap should be re-attached reversing the steps above. Ensure the o-ring is in place and perform a hi-pot test for safety once everything is complete.

Heat Sensor and Seal Failure Connections:

If a Hydromatic control panel is used, terminal blocks are provided for heat sensor and seal failure connections. If a control panel is supplied by others, it must allow heat sensor and seal failure terminations.

Installing Sump Level Control Float Controls:

In either simplex, duplex or triplex systems the lower or turn-off control is to be set to maintain a minimum level in the sump. This level shall be no more than 3 1/4" from the top of the motor housing down to the surface of the sewage.

The second, or turn-on control, is set above the lower turn-off control. The exact distance between the two floats must be a compromise between a frequent pumping cycle (10 starts per hr. max.) to control septicity, solids and a slower cycle for energy economy. This distance should be determined by the engineer or consulting engineer, depending on the conditions of the application.

Pump Operations

WARNING: Keep hands and clothing away from cutters and impeller!

1. If pump is 3 phase, the rotation of the impeller must first be checked. Lift pump from sump, lay it down, and quickly turn pump on and then off.

The impeller should turn counterclockwise when viewed from the suction. If rotation is wrong, turn off main breaker and interchange any two line leads to motor to correct rotation.

If pump is single phase, no rotation check is necessary.

2. Run water into sump until motor is covered.
3. Open gate valve in discharge line.
4. Turn pump on. If pump runs and sump liquid does not pump down, stop pump and close discharge gate valve. Then lift pump until sealing flange is open to vent off trapped air. Lower pump, open discharge valve, and start the pump again.
5. If pump is 3 phase, piped in permanently, and still does not operate properly after venting, rotation is wrong and can be reversed by interchanging any two line leads.
6. Level controls should be set in accordance with "Installing Sump Level Control Float Controls".

CAUTION: Be sure ground wire is connected to a good ground. This is important for safety.

Pump Maintenance

As the motors are oil filled, no lubrication or other maintenance is required.

If the heat sensor and seal failure are hooked up properly, no attention is necessary as long as the seal failure indicator light doesn't come on. To ensure continuity of the seal sensor leads, a test light is provided on intrinsically safe Hydromatic® panels as standard equipment.

Pump should be checked every quarter for corrosion and wear.

Servicing Instructions:

Field Service on Hydromatic Hazardous Location Pumps:

If a Hydromatic hazardous location pump is used in a hazardous location, or if the pump is still in warranty, the pump must be returned to the factory for service or repaired at an authorized Hydromatic service center. This will ensure the integrity of the hazardous location rating of the pump and comply with the warranty requirements.

Disconnecting Pump Cords:

If a Hydromatic hazardous location pump is to be removed from its location, the pump cords may be disconnected at the control panel (on sump mounted control panels) and cord assembly taken with pump.

CAUTION: If cord openings from sump to control panel are open, gases from sump could enter panel and an explosive condition could exist. Seal openings!

Replacing Cords:

The power cord and heat sensor/seal failure cord are potted into the connection box cap, forming the cord and cap assembly.

If cords require replacement due to damage or cords being too short, cord and cap assembly must be replaced as a complete assembly from the factory. Check pump for proper rotation before returning to normal service.

Replacing Grinder Parts:

If necessary to replace grinder parts because of wear or to inspect for clogging:

1. Close gate valve at pump discharge.
2. Turn off circuit breaker.
3. Remove pump from sump.
4. Remove machine screws and remove cutter ring retainer. Remove cutter ring.
5. Unscrew cap screws and remove volute case.
6. Radial cutter and axial cutter are now exposed. If checking for clogging, these parts can now be cleaned without removing them from the shaft.
7. If necessary to replace cutters, remove screw, washer, and radial cutter from shaft.

Radial cutter and impeller are screwed onto shaft. The thread is right-hand. Tap radial cutter with plastic hammer if necessary to loosen. Axial cutter lifts off impeller and is held from rotation by pin. Unscrew impeller from shaft in same manner as radial cutter, and remove washer.

8. Clean all parts thoroughly before proceeding with assembly. Make sure spring pin is inserted into impeller. Replace case volute and cap screws.
9. Replace cutter ring and cutter ring retainer with machine screws.

10. Plug pump into power and operate for a few seconds only to ensure parts are not rubbing.

Replacing Lower Seal, Impeller or Volute:

The wet end components may be repaired or replaced by an authorized Hydromatic service facility without compromising the hazardous location rating to the pump.

NOTE: Any time the seal is disturbed, it must be replaced.

Pump Troubleshooting

No liquid delivered.

1. Pump air bound
2. Discharge head too high
3. Pump or piping plugged
4. Wrong rotation
5. Speed too low

Insufficient liquid delivered.

1. Discharge head too high
2. Impeller or cutters partially plugged or damaged
3. Wrong rotation
4. Incorrect diameter impeller
5. Speed too low

Insufficient discharge pressure.

1. Wrong rotation
2. Air or gases in liquid
3. Impeller damaged
4. Incorrect impeller diameter
5. Speed too low

Pump overloads motor.

1. Wrong rotation
2. Specific gravity or viscosity of liquid too high
3. Speed too high

4. Head lower than rating, pumping too much liquid
5. Pump clogged
6. Defective bearings
7. Defective impeller

Pump is noisy.

1. Defective bearings
2. No axial clearance between impeller and volute
3. No axial clearance between radial cutter and cutter ring

If the cause of the trouble cannot be determined and corrected, contact the factory or an authorized Hydromatic® service facility.

Wiring Diagrams

1 PHASE

BLACK, WHITE, AND RED MOTOR LEADS CAN ONLY BE CONNECTED TO PANEL TERMINAL BLOCKS AS SHOWN ON SCHEMATIC. INCORRECT CONNECTION CAN CAUSE DAMAGE TO PUMP AND/OR PANEL COMPONENTS. THREE PHASE OVERLOAD RELAY MUST BE CLASS 10 TRIP & AMBIENT COMPENSATED & CONNECTED IN THE 'DAISY CHAIN' CIRCUIT AS SHOWN.

Notes:

- 1) Level Switches Must Be Rated a Minimum of 2 Amps at 120 Volts
- 2) Torque all white field wiring terminals to 20 In.Lbs.
- 3) Field Wiring Must Be 60°C Copper Wire Minimum.
- 4) ----- = Items Not Supplied In Control Panel.
- 5) Pump power, heat sensor, and seal probe cables must pass through approved NEC 501.15 conduit seals.

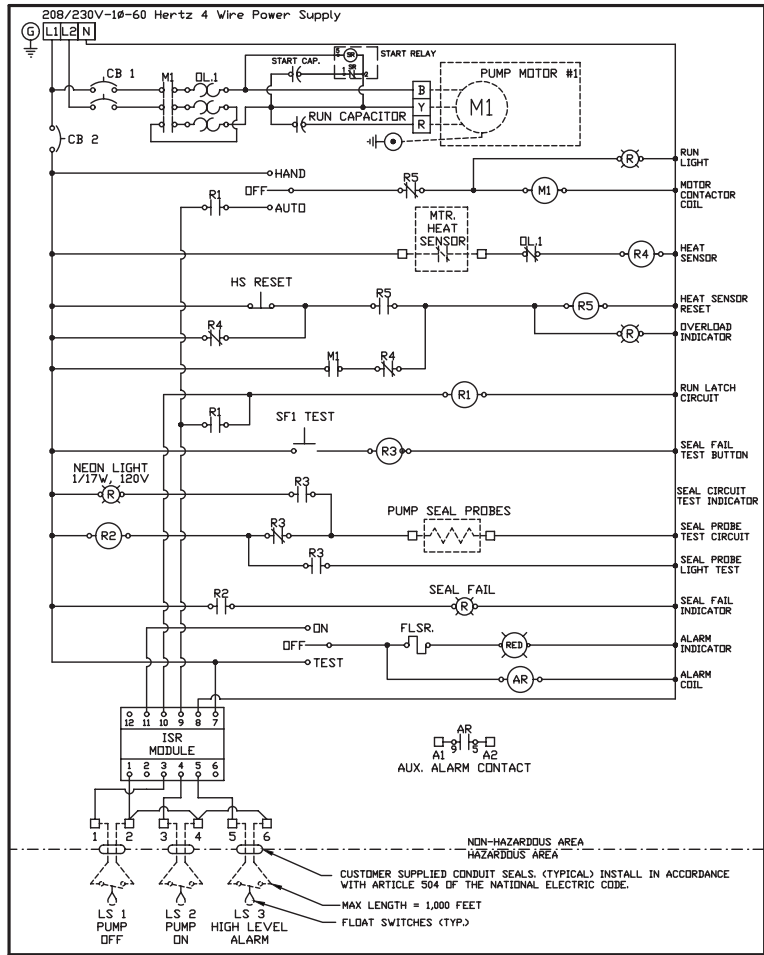

3 PHASE

- Notes:
- 1) Level Switches Must Be Rated a Minimum of 2 Amps at 120 Volts
 - 2) Torque all white field wiring terminals to 20 In.Lbs.
 - 3) Field Wiring Must Be 60°C Copper Wire Minimum.
 - 4) ----- = Items Not Supplied In Control Panel.
 - 5) Pump power, heat sensor, and seal probe cables must pass through approved NEC 501.15 conduit seals.

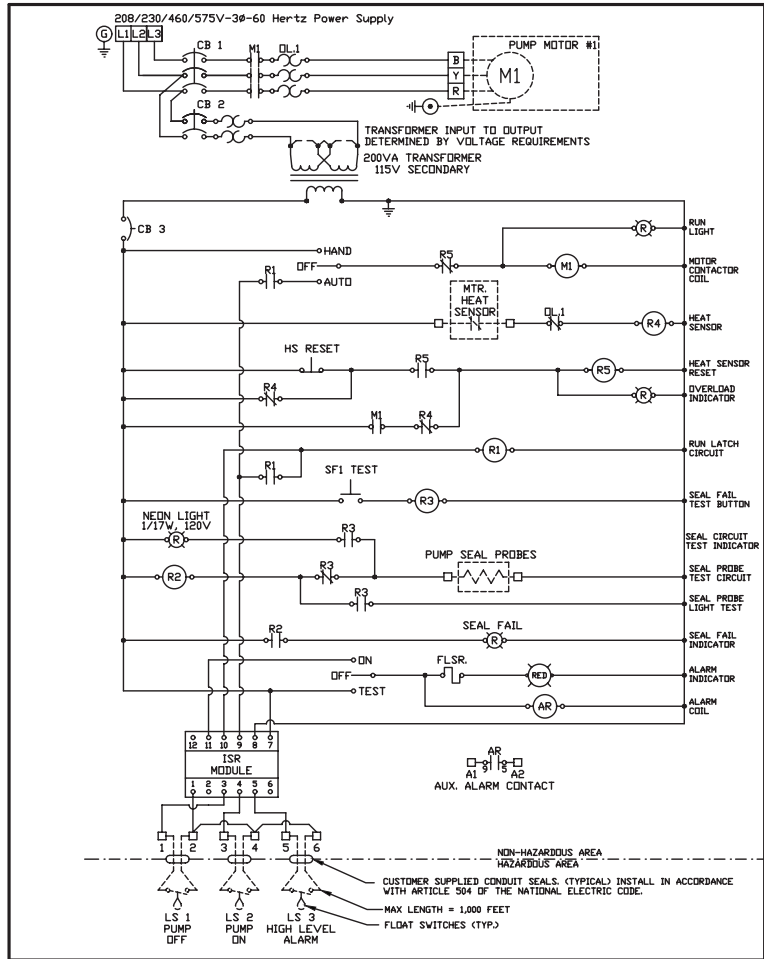

HPGX200 Parts List

Ref. No.	Part No.	Part Description	Qty.
1	152750325	35' Cord Assembly - 14-4	1
	152750305	35' Cord Assembly - 12-4	1
	152750315	35' Cord Assembly - 10-4	1
2	19100A029	Screw - Cap	2
3	05876A244	O-Ring	S 1
4	108980001	Connector	2
5	077630001	Cutter Retaining Ring	1
6	049180001	Lower Seal Seat	S 1
7	054050012	Radial Cutter	1
8	05876A120	O-Ring	S 1
9	109000015	Seal Sensor Assy.	1
10	109010011	Seal Failure Probe	2
11	000650271	Lower Bearing	1
12	055060022	Axial Cutter	1
13	05876A103	O-Ring	S 1
14	055050002	Cutter Ring	1
15	008340231	O-Ring	S 1
16	054040075	Seal Plate Assy.	1
17	070333022	Impeller - 5.00" Diameter	1
	070333032	Impeller - 4.75" Diameter	1
	070333042	Impeller - 4.50" Diameter	1
	070333052	Impeller - 4.25" Diameter	1
	070333062	Impeller - 4.00" Diameter	1
	070333072	Impeller - 3.75" Diameter	1
18	000190011	Machine Screw - (Rd Hd)	3
19	055700051	Impeller Washer	1
20	148850001	Impeller Screw	1
21	054190011	Roll Pin	1
22	049170001	Lower Seal - (Rotating)	S 1
23	109570002	Volute	1
24	105-014034-263	Screw - Socket	4
25	009750021	Snap Ring	1
26	109561002	Seal Housing	1
27	003000001	Upper Seal	S 1
28	001780061	Screw - Socket	4
29	001450101	Machine Screw	4
30	05454A009	Lock Washer	4
31	21573C102	Stator - 2 hp, 230/460/3/60	1
	21573C101	Stator - 2 hp, 200/3/60	1
	21573C103	Stator - 2 hp, 575/3/60	1
	21573C100	Stator - 2 hp, 230/1/60	1
	21573C104	Stator - 2 hp, 200/1/60	1
32	108231015	Rotor & Shaft Assy. - 2 hp, 3φ	1
	108321015	Rotor & Shaft Assy. - 2 hp, 1φ	1
33	134940042	Motor Housing	1
34	000650011	Upper Bearing	1
35	000640011	Wave Spring	1
	517005007	Seal Kit	
	131880001	Shim - Cutter	As Req'd.
	006280391	Shim - Impeller	As Req'd.

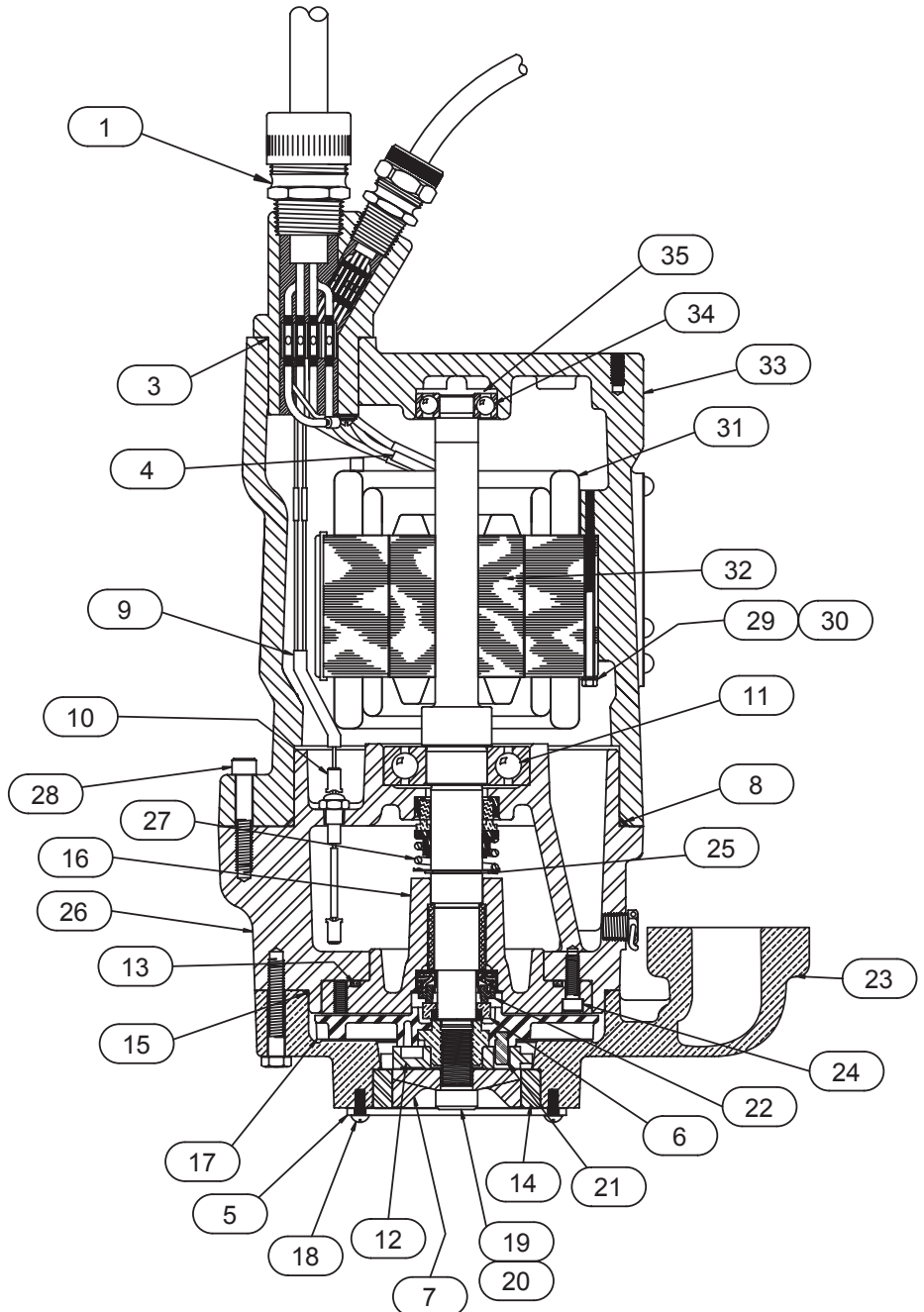
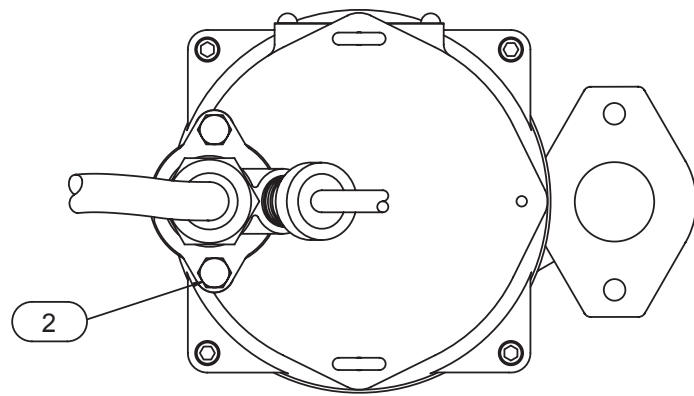

Notes: S — Parts in Seal Kit.

STANDARD LIMITED WARRANTY

Pentair Hydromatic® warrants its products against defects in material and workmanship for a period of 12 months from the date of shipment from Pentair Hydromatic or 18 months from the manufacturing date, whichever occurs first – provided that such products are used in compliance with the requirements of the Pentair Hydromatic catalog and technical manuals for use in pumping raw sewage, municipal wastewater or similar, abrasive-free, noncorrosive liquids.

During the warranty period and subject to the conditions set forth, Pentair Hydromatic, at its discretion, will repair or replace to the original user, the parts that prove defective in materials and workmanship. Pentair Hydromatic reserves the right to change or improve its products or any portions thereof without being obligated to provide such a change or improvement for prior sold and/or shipped units.

Start-up reports and electrical schematics may be required to support warranty claims. Submit at the time of start up through the Pentair Hydromatic website: <http://forms.pentairliterature.com/startupform/startupform.asp?type=h>. Warranty is effective only if Pentair Hydromatic authorized control panels are used. All seal fail and heat sensing devices must be hooked up, functional and monitored or this warranty will be void. Pentair Hydromatic will cover only the lower seal and labor thereof for all dual seal pumps. Under no circumstance will Pentair Hydromatic be responsible for the cost of field labor, travel expenses, rented equipment, removal/reinstallation costs or freight expenses to and from the factory or an authorized Pentair Hydromatic service facility.

This limited warranty will not apply: (a) to defects or malfunctions resulting from failure to properly install, operate or maintain the unit in accordance with the printed instructions provided; (b) to failures resulting from abuse, accident or negligence; (c) to normal maintenance services and parts used in connection with such service; (d) to units that are not installed in accordance with applicable local codes, ordinances and good trade practices; (e) if the unit is moved from its original installation location; (f) if unit is used for purposes other than for what it is designed and manufactured; (g) to any unit that has been repaired or altered by anyone other than Pentair Hydromatic or an authorized Pentair Hydromatic service provider; (h) to any unit that has been repaired using non factory specified/OEM parts.

Warranty Exclusions: PENTAIR HYDROMATIC MAKES NO EXPRESS OR IMPLIED WARRANTIES THAT EXTEND BEYOND THE DESCRIPTION ON THE FACE HEREOF. PENTAIR HYDROMATIC SPECIFICALLY DISCLAIMS THE IMPLIED WARRANTIES OF MERCHANTABILITY AND FITNESS FOR ANY PARTICULAR PURPOSE.

Liability Limitation: IN NO EVENT SHALL PENTAIR HYDROMATIC BE LIABLE OR RESPONSIBLE FOR CONSEQUENTIAL, INCIDENTAL OR SPECIAL DAMAGES RESULTING FROM OR RELATED IN ANY MANNER TO ANY PENTAIR HYDROMATIC PRODUCT OR PARTS THEREOF. PERSONAL INJURY AND/OR PROPERTY DAMAGE MAY RESULT FROM IMPROPER INSTALLATION. PENTAIR HYDROMATIC DISCLAIMS ALL LIABILITY, INCLUDING LIABILITY UNDER THIS WARRANTY, FOR IMPROPER INSTALLATION. PENTAIR HYDROMATIC RECOMMENDS INSTALLATION BY PROFESSIONALS.

Some states do not permit some or all of the above warranty limitations or the exclusion or limitation of incidental or consequential damages and therefore such limitations may not apply to you. No warranties or representations at any time made by any representatives of Pentair Hydromatic shall vary or expand the provision hereof.



HYDROMATIC®

1101 MYERS PARKWAY
ASHLAND, OHIO 44805
PH: 855-274-8947

490 PINEBUSH ROAD, UNIT 4
CAMBRIDGE, ONTARIO, CANADA N1T 0A5
PH: 800-363-7867

WWW.HYDROMATIC.COM