

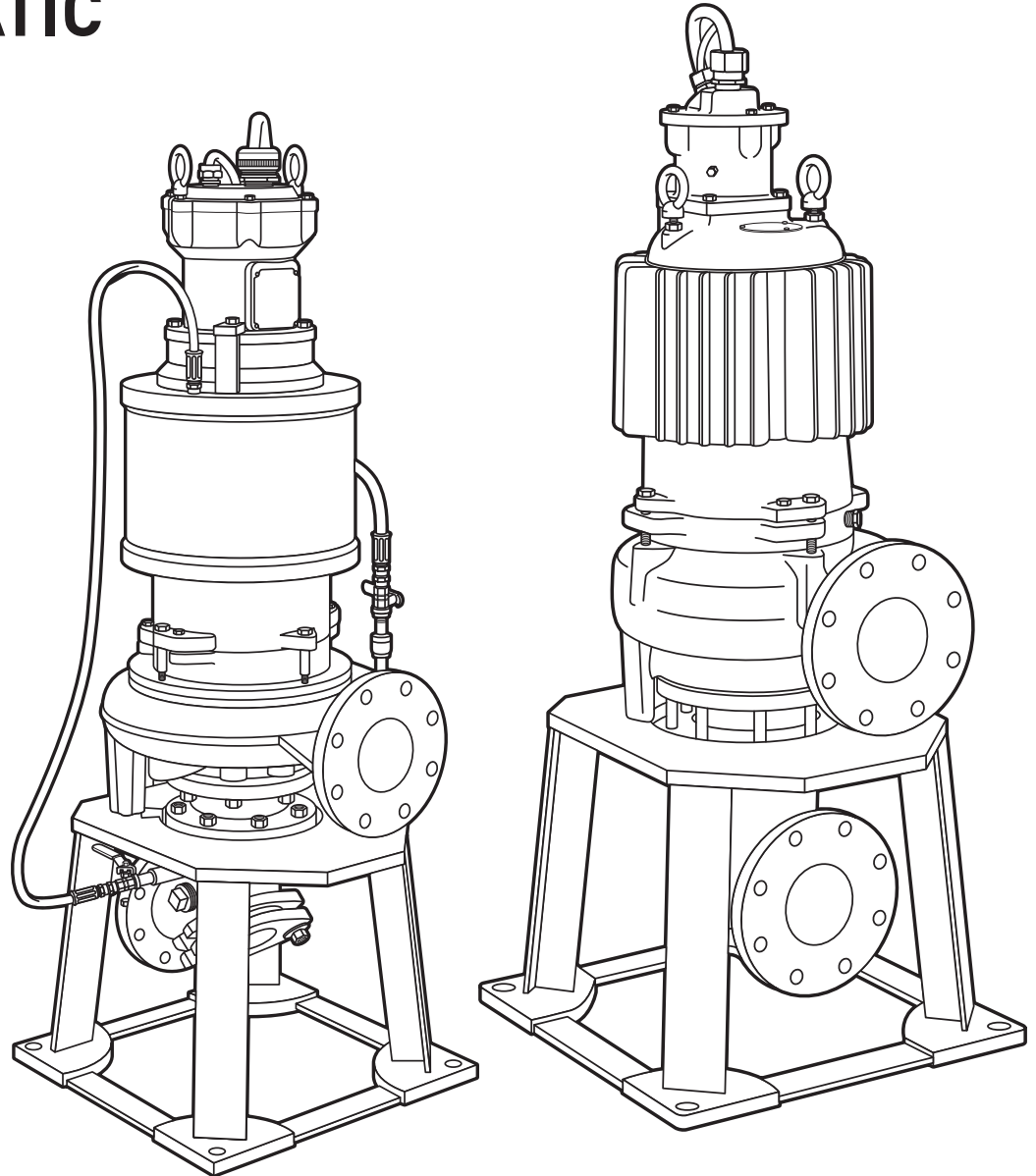

Model Discontinued  
For Reference Only

**HYDROMATIC®**



# MODEL DRY PIT SOLIDS HANDLING DRY PIT PUMPS

## INSTALLATION AND SERVICE MANUAL

NOTE! To the installer: Please make sure you provide this manual to the owner of the equipment or to the responsible party who maintains the system.

# General Information

## Shipping:

When unpacking unit, check for concealed damage. Claim for damage must be made at the receiving end through the delivering carrier. Damage cannot be processed from the factory.

## CALIFORNIA PROPOSITION 65 WARNING:

**▲WARNING** This product and related accessories contain chemicals known to the State of California to cause cancer, birth defects or other reproductive harm.

## Pumps Not Operating or in Storage:

Pumps with carbon ceramic seals must have impellers manually rotated (6 revolutions) after setting nonoperational for 3 months or longer and prior to electrical start-up.

Pumps with carbide seals must have impellers manually rotated (6 revolutions) after setting nonoperational for 3 weeks or longer and prior to electrical start-up.

## Seal Failure:

An electrode is installed in the seal chamber so if water enters the chamber through the first seal, the electrode will be energized and a signal will be transmitted to the sensing unit at ground surface, causing an alarm activation. The electrode probe is installed in all units, but the sensing unit is supplied at an extra cost and must be ordered.

In operation the seal failure unit indicates only that there is some water in the seal chamber. The pump will continue to operate, but the seal should be checked immediately after failure is indicated.

The sensing unit is recommended on all installations as good insurance against motor failure.

## Pump:

The dry pit submersible pump is supplied for 1 or 3 phase and for 200, 230, 460 or 575 volts. Power cable is supplied with green wire to connect to a good ground such as water pipe or ground stake.

## Heat Sensors:

All motors have heat sensor units embedded in the motor winding to detect excessive heat. The heat sensors are set to trip at 120°C. The sensors automatically reset when the motor cools to safe temperature.

The sensors are connected in series with the motor starter coil so that the starter is tripped if heat sensor opens. The motor starter is equipped with overload heaters so all normal overloads are protected by the starter.

**IMPORTANT: If Hydromatic® electrical starting equipment is not supplied, the heat sensor circuit must be connected in series with the starter coil or warranty is void.**

## Wet Well Level Control:

Sump level is controlled by Hydromatic switch controls. The float is held in position in the sump by a weight attached to the power cord above the float. The cord supports the float and is adjusted for height from the surface.

Duplex systems use three controls: one set at turn-off, one set at turn-on for one pump, and one set at turn-on for both pumps. Pumps then alternate lead and lag on each successive cycle. Two pumps operate together only when the sump level rises to the third or override control. The override control also brings on the second pump in case of failure of the first pump. Extra floats with appropriate

controls can be supplied for alarm functions. Triplex systems use four controls: One set at turn-off, one set at turn-on for one pump, one set at turn-on for two pumps, and one set at turn-on for three pumps. The pumps alternate with each successive cycle.

Three pumps operate together only if the sump level rises to the fourth control (second override). This control also brings on the third pump in case of failure of either or both of the first two pumps.

## Alarm Controls:

The alarm level is usually set above the override level so the alarm will signal only if the override level is exceeded. However, some engineers prefer to have the alarm level set below the override level as it is possible for one pump to fail and the other pump to operate on the override level with the sump level never reaching the alarm level. This is particularly true in cases of low inflow capacity.

## Electrical Control Panel:

It is recommended that the Hydromatic control panel be used with all pumps as proper starter heaters and connections for heat sensor wires are furnished.

Hydromatic electrical equipment is installed in a weatherproof NEMA 3R enclosure. The electrical equipment includes a main circuit breaker for each pump, a magnetic starter with overload protection for each pump, an H-O-A switch and a run light for each pump, an electrical alternator and a transformer to provide appropriate control for control circuit and alarms.

## Overload Heaters:

Starters with 3 leg overload protection must be supplied if the Hydromatic electrical panel is not used. The heaters must be sized in accordance with the nameplate

amps on the motor. The amp draw on these oil-filled motors is slightly higher than a corresponding horsepower surface motor, so heaters must be sized by the nameplate rating.

## Installation Instructions

### Installing Pump in Dry Pit:

Before installing pump in the dry pit, lay it on side and turn the impeller manually. The impeller may be slightly stuck due to factory water testing, so it must be broken loose with a small bar or screwdriver in the edge of the vanes. The impeller must turn freely.

Clean all trash and debris from pump installation area and connect pump to plumbing.

A check valve must be installed on each pump. A gate or plug valve in each pump discharge line is also recommended. This valve should be installed on the discharge side of the check valve so the line pressure can be cut off to service the check valve. Single pump systems are sometimes installed without a check valve where it is desirable to self drain the discharge line to prevent freezing. This can be done only with short discharge lines. Otherwise water will return to the sump and cause short cycling of the pump.

### Mounting Pump Stand:

The pump will ship from the factory on a dry pit pump stand. The suction and discharge of the pump will be oriented at the factory per the prescribed customer order.

The dry pit pump must be anchored to the pump station floor. This must be done to alleviate stress on the suction and discharge piping while the pump is in service. When securing the pump stand to the contractor supplied anchor bolts, it

may be necessary to shim the stand to ensure the suction and discharge piping properly aligns.

### Plumbing (General):

The site contractor must supply the use of necessary pipe hangers or other piping supports. Both the suction and discharge piping must be independently supported and properly aligned to ensure no strain is transmitted to the pump when connections are tightened. The use of expansion joints or vibration pads does not preclude the need to properly support the piping.

**NOTE: Do not support the piping by the pump. Do not force piping when making connections.**

### Suction-Inlet Piping:

The correct sizing and installation of the suction plumbing is particularly important. The suction piping must be selected and installed in such a manner that it minimizes pressure losses and allows for sufficient flow during starting and operation. Most NPSH problems can be traced directly to improper design of suction piping systems.

It is recommended that the piping be as direct as possible and the length should be at least 10 times the diameter of the pipe. When a pipe diameter larger than the suction of the pump is used, an eccentric reducer should be used with the eccentric side down. This will allow for the elimination of a potential air pocket in the suction plumbing.

**NOTE: A pipe diameter smaller than the suction of the pump must never be used.**

It is also recommended that a valve be installed in the suction piping to isolate the pump during routine maintenance and shutdown. A globe valve should not be used when NPSH is critical.

It is recommended that a compound pressure gauge be installed in the suction piping to assist in troubleshooting potential performance problems.

### Discharge-Outlet Piping:

The discharge piping for short runs can be of the same size as the discharge of the pump. It is recommended that longer runs be 1 to 2 sizes larger depending on the length. Any elevated points will retain air pockets, and it is recommended that air vents or bleed lines be installed at these points to evacuate the entrapped air. Installation of a valve near the discharge of the pump is recommended to isolate the pump during maintenance and shutdown.

It is recommended that a pressure gauge be installed near the discharge of the pump to assist in troubleshooting potential performance problems.

### NEMA 4 Junction Box (Optional):

A NEMA 4 junction box should be used to make power and control connections if electrical control panel is to be set remote from the pump station. The Hydromatic® NEMA 4 junction box is provided with compression connections for sealing all wires. No sealing compound is needed to make connections waterproof.

Wiring diagrams are provided with the panel for making connections. An extra set of diagrams is included so that one set can be used in the station when making connections. The size wire to use from panel to station depends on motor size and distance in feet.

Be sure each wire is checked out so that a wrong connection will not be made. An ohmmeter or Megger can be used to check the continuity.

## NUMBER OF CONDUCTORS REQUIRED BETWEEN CONTROL PANEL AND NEMA 4 JUNCTION BOX

Power lines and control wires can be carried in conduit or underground buried cable.

System Type	Number of Control Wires	Number of Power Lines	Number of Ground Wires #8	HEAT SENSOR & SEAL FAILURE	
				Number of Sensor Wires	Number of Ground Wires
Simplex	3	3	1	3	1
Simplex with Alarm	5	3	1	3	1
Duplex	5	6	1	6	2
Duplex with Alarm	7	6	1	6	2

### 208-230V SINGLE PHASE

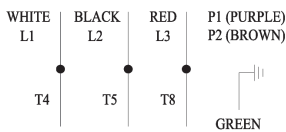

### 208 & 575V THREE PHASE

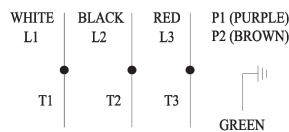

### 230V (DUAL VOLTAGE) THREE PHASE

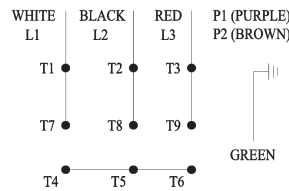

### 460V (DUAL VOLTAGE) THREE PHASE

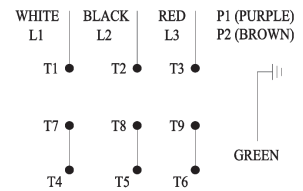

### Installing Switch Controls:

The controls are supported by a mounting bracket that is attached to wet well wall, cover or to the NEMA 4 junction box. Control level can be changed at any time by loosening the snubber and readjusting cord length.

In either a simplex or duplex system, the lower or turn-off control is set just above the drywell inlet. This is dependent on the inlet velocity of the pump. The second or turn-on control is set at least 24 inches above the lower turn-off control.

More distance between turn-on and turn-off controls can be used, but sewage may become septic, and excessive solids may collect for the pump to handle. A frequent pumping cycle is recommended for best operation.

If an alarm system is used, this control is usually set about 6 inches above the override control.

### Making Electrical Connections:

All electrical wiring must be in accordance with local codes.

**IMPORTANT: If equipment is not properly wired and protected as recommended, the warranty is void.**

### Heat Sensors and Seal Failure Connections:

Be sure heat sensor wires are connected in series with the starter coil. Connections are provided on the terminal strip.

**DO NOT CONNECT POWER TO THESE LINES AT ANY TIME.**

### Cooling Fins (Optional):

When additional cooling is required, cooling fins are permanently adhered to the motor housing at the factory. Inspect the cooling fins to ensure that they are intact and not damaged prior to plumbing the pump in the system.

**NOTE: The cooling fins must be intact to ensure the pump operates within the factory specified temperature.**

### Water Jacket (Optional):

When additional cooling is necessary, a water jacket is supplied from the factory. All necessary plumbing of the water jacket is supplied from the factory connecting to the suction and the discharge piping. The plumbing includes ball valves, allowing for removal of the water jacket for periodic cleaning without shutting the system down.

The water jacket is held in place by clamps and is sealed both top and bottom by O-rings. Upon removal of the water jacket for cleaning, care should be taken not to damage the O-rings. Replace if necessary.



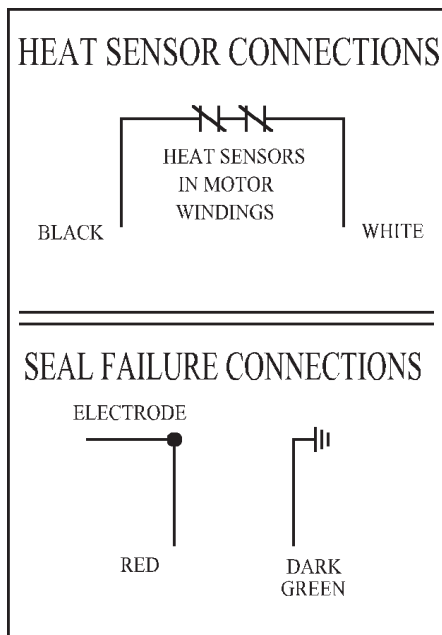

**NOTE:** Clean, fresh water supplied to the water jacket will reduce the necessity of frequent periodic cleaning of the water jacket. This does not preclude that the water jacket should not periodically be cleaned.

## Pump Operation

### Starting System:

1. Turn H-O-A switch to Off position and then turn on main circuit breakers.
2. Open all discharge valves and allow water to rise in wet well.
3. Turn H-O-A switch to Hand position on one pump and notice operation. If pump is noisy and vibrates, rotation is wrong. To change rotation, interchange any two line leads to a three phase motor only. **DO NOT INTERCHANGE MAIN INCOMING LINES.** If duplex system, check second pump in the same manner.
4. Now set H-O-A switch to Auto position and allow water to rise in the wet well until the pump

starts. Allow pump to operate until the level drops to turn-off point.

5. Allow wet well level to rise to start the other pump. Notice run lights on the panel. Pumps should alternate on each successive cycle of operation.
6. Turn both H-O-A switches to Off position and allow wet well to fill to the override control level.
7. Turn both switches to Auto position and both pumps should start and operate together until level drops to turn-off point.
8. Repeat this operation cycle several times before leaving job site.
9. Check voltage when pumps are operating and check amp draw of each pump. Check amps on each wire, as sometimes a high leg will exist. One leg can be somewhat higher (5 to 10%) without causing trouble. For excessive amp draw on one leg, the power company should be consulted.

### Phase Converters:

Phase converters are generally not recommended, but in cases where only single phase current is available, phase converters can be used. Be sure to size the phase converter large enough for the amp draw specified on the motor nameplate, not necessarily by motor horsepower. The warranty of all three phase submersible motors is void if operated with single phase power through a phase converter and 3 leg ambient compensated extra-quick trip overload protectors are not used.

## Pump Maintenance

Lubrication or other maintenance is not required, as the motors are oil filled.

Generally, these pumps give very reliable service, and can be expected to operate for many years without failure under normal operating conditions.

### Lightning:

In some areas where considerable lightning occurs, we recommend that a lightning arrestor be installed at the control panel. Lightning arrestors are good insurance against damage to an expensive motor.

### Servicing Instructions:

**IMPORTANT:** Read all instructions prior to replacing any parts.

**WARNING:** Before handling these pumps and controls, always isolate and disconnect power first.

**Do not smoke or use any sparkable electrical devices or flames in a septic (gaseous) or possible septic environment.**

### Field Service on Motor:

All dry pit pump motors out of warranty can be serviced in the field by any reliable motor service shop. Any pump (in warranty) must be returned to the factory for service or repaired at an authorized Hydromatic® service center. Charges will not be allowed if (in warranty) pump is not taken to an authorized Hydromatic service center.

When field service is performed on a pump, these instructions should be carefully followed.

## Replacing Stator:

1. Un-plumb and drain water jacket if pump was supplied with a water jacket and remove.
2. If stator only is damaged it may not be necessary to completely dismantle pump as stator and housing can be lifted from pump without disturbing seals or bearings.
3. Drain all oil from upper housing, remove drain plug in bottom of stator housing and remove plug in top of housing to allow air to enter.
4. After chamber is drained, remove hold-down bolts and lift off. Use care in lifting as the seal failure connecting wires must be disconnected before housing is completely removed.
5. Set assembly on bench and remove connection box. When box is lifted off, connection wires to motor will be exposed. These wires will probably be burned, but each wire will be identified with a metal wire marking number. Cut the wires.  
  
If the leads in the connection box are burned, a complete new connection box with new wires must be used. The wires are potted in with sealing compound and a new unit must be obtained from the factory.
6. The stator is held in the housing with a bolted-in clamp ring.
7. After ring is removed, turn housing upright and bump on hardwood blocks. This should jar the stator loose and allow it to drop out.
8. Thoroughly clean housing before replacing new stator. Replace stator and make all wire connections to the connection box before replacing housing on pump. This is important as

leads must be tucked behind the windings by using hands up through rotor core.

**IMPORTANT: Use only compression type insulated connectors on the wires.**

**Do not tape leads as oil will deteriorate the tape and cause damage to stator and bearings.**

9. Check top bearing. If clean and does not turn rough, bearings can be reused and it is not necessary to completely dismantle pump and change bearings. If bearings are damaged with dirt or heat they must be replaced. Remember to reinstall the upper bearing load spring.
10. Replace stator housing onto seal chamber and bolt in place. **BE SURE SEAL FAILURE WIRE IS CONNECTED BEFORE HOUSING IS ASSEMBLED.**  
  
Be sure O-ring seal has been replaced. If O-ring appears nicked or cut, replace with new ones. This applies to O-rings in the assembly.
11. After all leads are reconnected in the connection box, make a high voltage ground test on each wire. The only wire that should show ground is the green power lead and the ground lead in the auxiliary power cable.
12. For safety, complete pump should be air checked under water for leaks. Lay pump on side for this oil filling with oil fill hole upright. Do not completely fill; leave oil about 1 inch below plug hole. Use only Hydromatic® submersible oil in this chamber or high grade transformer oil. Replace plug; use Permatex on threads. Install air valve in top plug opening of motor housing and

charge housing with about 10 psi of air. Be sure air is dry. Do not use air line where water may be trapped in the line. Submerge complete unit under water and check for leaks.

13. Refill motor chamber with oil. Use only a high grade transformer oil or Hydromatic special submersible oil. Fill chamber until oil covers top of windings. Leave air space in top for expansion. Use Permatex on plug threads.

## Replacing Seals and Bearings:

1. Drain all oil from motor chamber and seal chamber as described.
2. Remove motor housing as described.
3. Remove bolts that hold seal chamber to pump housing. Use back-off screws to break loose.
4. Lift rotating assembly (rotor, shaft, and impeller) from pump case and place it horizontally on bench.
5. Remove impeller by holding the rotor and removing the impeller retaining washer and bolt. The impeller will be taper fitted to the shaft with a key. The impeller may need to be jarred from the shaft by tapping with a block of wood.
6. A shaft sleeve may be used in conjunction with the lower seal and will need to be removed.
7. Remove lower seal spring and pry out the seal with a screwdriver.
8. To remove the seal housing, take out socket head bolts and using the bolts in the back-out holes, pry plate loose. This will force out lower seal if not already removed.

9. Remove snap ring that holds upper seal. Pull seal if it is free. If not free, it can be forced off when shaft is removed.
  10. Remove 4 bolts that hold bearing housing in place. Set assembly in upright position and bump end of shaft with hardwood block. This will push the bearing from the housing and will force upper seal from shaft.
  11. Use a bearing puller to remove bearings. Replace with new bearings. Press only on inner face of the bearing when replacing. Pressing on the outer face can damage the bearing.
- IMPORTANT: DO NOT USE ANY OF THE OLD SEAL PARTS. REPLACE WITH ALL NEW SEALS.**
12. Thoroughly clean all castings before replacing seals. Any dirt between the seal faces can cause failure.
  13. Examine all O-rings for nicks before using and replace damaged O-rings with new ones.
  14. Use Loctite® on socket head impeller locking screw in end of shaft.

## **Pump Troubleshooting**

### **Pump will not start.**

1. No power to the motor. Check for blown fuse or open circuit.
2. Selector switch may be in the Off position.
3. Control circuit transformer fuse may be blown.
4. Overload heater on starter may be tripped. Push to reset.

### **Pump will not start and overload heaters trip.**

1. Turn off power and check motor leads with Megger or ohmmeter for possible ground.
2. Check resistance of motor windings. All 3 phases should show the same reading.
3. If no grounds exist and the motor windings check OK, remove discharge elbow cover and check for clogged or blocked impeller.

### **Pump operates with selector switch in Hand position but will not operate in Auto position.**

1. This indicates trouble in the float level control or alternator relay.
2. Check the control panel for trouble.

### **Pump runs but will not shut off.**

1. Pump may be air locked. Turn pump off and let set for several minutes, then restart.
2. Lower float control may be hung up in the closed position. Check in wet well to be sure the control is free.
3. Selector switch may be in the Hand position.

### **Pump does not deliver proper capacity.**

1. Discharge gate valve may be partially closed or partially clogged.
2. Check valve may be partially clogged. Raise lever up and down to clear.
3. Pump may be running in the wrong direction. Low speed pumps can operate in reverse direction without much noise or vibration.

4. Discharge head may be too high. Check total head with gauge when the pump is operating.
5. If pump has been in service for some time and capacity falls off, remove pump and inspect impeller for wear.

### **Motor stops and then restarts after short period but overload heaters in starter do not trip.**

1. This indicates heat sensors in the motor are tripping due to excessive heat. Impeller may be partially clogged, giving sustained overload but not high enough to trip overload heaters.
2. Pump may be operating on a short cycle due to faulty check valve in the wet well.

## STANDARD LIMITED WARRANTY

Pentair Hydromatic® warrants its products against defects in material and workmanship for a period of 12 months from the date of shipment from Pentair Hydromatic or 18 months from the manufacturing date, whichever occurs first – provided that such products are used in compliance with the requirements of the Pentair Hydromatic catalog and technical manuals for use in pumping raw sewage, municipal wastewater or similar, abrasive-free, noncorrosive liquids.

During the warranty period and subject to the conditions set forth, Pentair Hydromatic, at its discretion, will repair or replace to the original user, the parts that prove defective in materials and workmanship. Pentair Hydromatic reserves the right to change or improve its products or any portions thereof without being obligated to provide such a change or improvement for prior sold and/or shipped units.

Start-up reports and electrical schematics may be required to support warranty claims. Submit at the time of start up through the Pentair Hydromatic website: <http://forms.pentairliterature.com/startupform/startupform.asp?type=h>. Warranty is effective only if Pentair Hydromatic authorized control panels are used. All seal fail and heat sensing devices must be hooked up, functional and monitored or this warranty will be void. Pentair Hydromatic will cover only the lower seal and labor thereof for all dual seal pumps. Under no circumstance will Pentair Hydromatic be responsible for the cost of field labor, travel expenses, rented equipment, removal/reinstallation costs or freight expenses to and from the factory or an authorized Pentair Hydromatic service facility.

This limited warranty will not apply: (a) to defects or malfunctions resulting from failure to properly install, operate or maintain the unit in accordance with the printed instructions provided; (b) to failures resulting from abuse, accident or negligence; (c) to normal maintenance services and parts used in connection with such service; (d) to units that are not installed in accordance with applicable local codes, ordinances and good trade practices; (e) if the unit is moved from its original installation location; (f) if unit is used for purposes other than for what it is designed and manufactured; (g) to any unit that has been repaired or altered by anyone other than Pentair Hydromatic or an authorized Pentair Hydromatic service provider; (h) to any unit that has been repaired using non factory specified/OEM parts.

**Warranty Exclusions:** PENTAIR HYDROMATIC MAKES NO EXPRESS OR IMPLIED WARRANTIES THAT EXTEND BEYOND THE DESCRIPTION ON THE FACE HEREOF. PENTAIR HYDROMATIC SPECIFICALLY DISCLAIMS THE IMPLIED WARRANTIES OF MERCHANTABILITY AND FITNESS FOR ANY PARTICULAR PURPOSE.

**Liability Limitation:** IN NO EVENT SHALL PENTAIR HYDROMATIC BE LIABLE OR RESPONSIBLE FOR CONSEQUENTIAL, INCIDENTAL OR SPECIAL DAMAGES RESULTING FROM OR RELATED IN ANY MANNER TO ANY PENTAIR HYDROMATIC PRODUCT OR PARTS THEREOF. PERSONAL INJURY AND/OR PROPERTY DAMAGE MAY RESULT FROM IMPROPER INSTALLATION. PENTAIR HYDROMATIC DISCLAIMS ALL LIABILITY, INCLUDING LIABILITY UNDER THIS WARRANTY, FOR IMPROPER INSTALLATION. PENTAIR HYDROMATIC RECOMMENDS INSTALLATION BY PROFESSIONALS.

Some states do not permit some or all of the above warranty limitations or the exclusion or limitation of incidental or consequential damages and therefore such limitations may not apply to you. No warranties or representations at any time made by any representatives of Pentair Hydromatic shall vary or expand the provision hereof.



### HYDROMATIC®

740 EAST 9TH STREET  
ASHLAND, OHIO, USA 44805  
419-289-1144

490 PINEBUSH ROAD, UNIT #4  
CAMBRIDGE, ONTARIO, CANADA N1T 0A5  
800-363-PUMP

[WWW.HYDROMATIC.COM](http://WWW.HYDROMATIC.COM)