

## HYDROMATIC®

### SAFETY INFORMATION

Carefully read and follow all safety instructions in this manual or on pump.

**⚠** This is the safety alert symbol. When you see this symbol on your pump or in this manual, look for one of the following signal words and be alert to the potential for personal injury!

**⚠ DANGER** warns about hazards that **will** cause serious personal injury, death or major property damage if ignored.

**⚠ WARNING** warns about hazards that **can** cause serious personal injury, death or major property damage if ignored.

**⚠ CAUTION** warns about hazards that **will** or **can** cause minor personal injury or property damage if ignored.

The word **NOTICE** indicates special instructions which are important but not related to hazards.

1. **Read these rules and instructions carefully.** Failure to follow them could cause serious bodily injury and/or property damage.
2. Check your local codes before installing. You must comply with their rules.
3. Vent sewage or septic tank according to local codes.
4. Do not install pump in any location classified as hazardous by National Electrical Code, ANSI/NFPA 80-1984 or the Canadian Electrical Code.

**⚠ WARNING** Hazardous voltage. Can shock, burn, or kill. During operation the pump is in water. To avoid fatal shocks, proceed as follows if pump needs servicing:

Do not smoke or use devices that can generate sparks in a septic (gaseous) environment.

- 5A. Disconnect power to outlet box before unplugging pump.
- 5B. Take extreme care when changing fuses. Do not stand in water or put your finger in the fuse socket.
- 5C. Do not modify the cord and plug. When using the cord and plug, plug into a grounded outlet only. When wiring to a system control, connect the pump ground lead to the system ground.

### MOTOR, SWITCH, & CORD SPECIFICATIONS

| Model Number | Motor HP | Voltage | Motor Full Load Amps | Individual Branch Circuit Required (Amps) | Cord Length in ft. (m) | Switch Setting in inches (mm) |             | Discharge Adapter Size |
|--------------|----------|---------|----------------------|---|------------------------|-------------------------------|-------------|------------------------|
|              |          |         |                      |   |                        | On                            | Off         |                        |
| BV40AW1      | 4/10     | 115/1   | 12.6                 | 15  | 10 (3.0)               | 12-1/2 (317)                  | 6-1/2 (165) | 2"                     |
| BV40AD1      | 4/10     | 115/1   | 12.6                 | 15  | 10 (3.0)               | 14-1/2 (368)                  | 6 (152)     | 2"                     |

6. Be sure that construction and access to septic sumps conform with all OSHA requirements.
7. Do not run the pump dry. Dry running can overheat the pump, (causing burns to anyone handling it) and will void the warranty.
8. The pump normally runs hot. To avoid burns when servicing pump, allow it to cool for 20 minutes after shutdown before handling it.
9. The pump is permanently lubricated. No oiling or greasing is required in normal operation. For overhaul, see instructions under "Service".



#### California Proposition 65 Warning

**⚠ WARNING** This product and related accessories contain chemicals known to the State of California to cause cancer, birth defects or other reproductive harm.

### DESCRIPTION

This submersible sewage ejector pump is designed for residential wastewater removal, sewage applications, sump drainage, dewatering and flood control. Units have built in thermal overload protection with automatic reset. The mechanical seal and bearings on the motor shaft are permanently lubricated. Stainless steel hardware and a heavy duty lift out handle allow for easy disassembly after extended use.

**NOTICE:** This unit is not designed for applications involving salt water or brine! Use with salt water or brine will void warranty.

### SPECIFICATIONS

Power supply required..... See "Motor, Switch and Cord Specifications" chart below

Motor duty..... Intermittent  
Maximum Liquid Temperature ..... 120°F (49°C)  
Discharge Adapter ..... 2" NPT

## PERFORMANCE

| GPM AT TOTAL FEET              |    |    |    | No flow at height shown below |
|--------------------------------|----|----|----|-------------------------------|
| Model                          | 0  | 5  | 15 |                               |
| <b>CAPACITY GALLONS/MINUTE</b> |    |    |    |                               |
| BV40AW1                        | 78 | 70 | 35 | 20'                           |
| BV40AD1                        | 78 | 70 | 35 | 20'                           |

## INSTALLATION

**⚠ WARNING** **Hazardous voltage. Can shock, burn or kill.**  
Do not lift pump by the power cord. See "Cord Lift Warning" below.

**NOTICE:** Install the pump on a hard, level surface (cement, asphalt, etc.). Never place the pump directly on earth, clay or gravel surfaces. Install the pump in a sump basin with a minimum diameter of 18" (46cm).

### Piping

Piping must not be smaller than pump discharge.

When installed in a **sewage** system, the pipe must be capable of handling semi-solids of at least 2" (51mm) in diameter.

When installed in an **effluent** system, the pipe must be capable of handling semi-solids of at least 3/4" (19mm) in diameter.

The rate of flow in the discharge pipe must keep any solids present in suspension in the fluid. To meet minimum flow requirements (2 feet per second in the discharge line), size the pipe as follows:

| A Pipe Size Of: | Will Handle a Flow Rate Of: |
|-----------------|-----------------------------|
| 1-1/2" (38mm)   | 12 GPM                      |
| 2" (51mm)       | 21 GPM                      |
| 2-1/2"(64mm)    | 30 GPM                      |
| 3"(76mm)        | 48 GPM                      |

In a **sewage** system use a 2" (51mm) check valve in pump discharge to prevent backflow of liquid into sump basin. The check valve should be installed 12 – 18" (317 – 457mm) above the pump discharge and be a free flow valve that will easily pass solids. Be sure check valve installation complies with local codes.

In an **effluent** system use a 1-1/2" (38mm) check valve in pump discharge to prevent backflow of liquid into sump basin.

**NOTICE:** For best performance of check valve when handling solids, do not install it with the discharge more than 45° above the horizontal. Do not install the check valve in a vertical position as solids may settle in the valve and prevent it from opening on startup.

Drill a 3/16" (5mm) hole in the discharge pipe about 1–2" (25-51mm) above the pump discharge connection (but below check valve) to prevent airlocking the pump.

Be sure that the wide-angle float switch hangs freely. It should not be able to come in contact with the sides or bottom of the sump pit.

Make sure the sump pit is free of any debris that could obstruct the intake volute or switch.

Use plumbing materials that are approved by local building codes when connecting pipes between pump and sewer outlet.

**NOTICE:** For critical indoor installations where additional high water protection is desired, install a "Q-Alert" audible alarm system in the sump pit. For outdoor installations, confer with your Hydromatic distributor.

Connect the power cord to a 3-prong grounded AC receptacle.

**⚠ WARNING** **Hazardous voltage. Can shock, burn or kill.**

**DO NOT** remove the grounding pin from the power cord. Avoid using extension cords or 2-prong adapter plugs.

Insert the piggyback plug that comes from the wide-angle float switch directly into the power receptacle.

Insert the pump power cord directly into the back of the piggyback receptacle.

Test the pump installation by filling the sump basin with enough water to activate the pump and repeat this cycle until satisfied with pump operation.

### Electrical

**⚠ WARNING** **Hazardous voltage. Can shock, burn, or kill.** When installing, operating, or servicing this pump, follow the safety instructions listed below.

- DO NOT** splice the electrical power cord.
- DO NOT** allow the plug on the end of the electrical cord to be submerged.
- DO NOT** use extension cords. They are a fire hazard and can reduce voltage sufficiently to prevent pumping and/or damage motor.
- DO NOT** handle or service the pump while it is connected to the power supply.
- DO NOT** remove the grounding prong from the plug or modify the plug. To protect against electrical shock, the power cord is a three-wire conductor and includes a 3-prong grounded plug. Plug the pump into a 3-wire, grounded, grounding-type receptacle. Connect the pump according to the NEC or CEC and local codes.

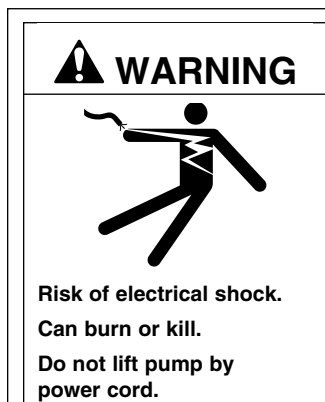

### CORD LIFT WARNING

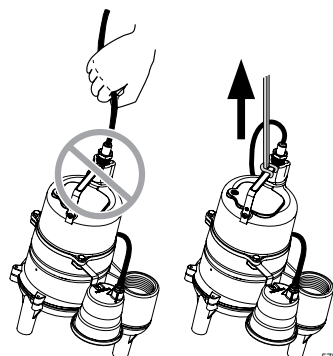

- Attempting to lift or support pump by power cord can damage cord and cord connections.
- Cord may pull apart, exposing bare wires with possibility of fire or electrical shock.
- Lifting or supporting pump by power cord will void warranty.
- Use lifting ring or handle on top of pump for all lifting/lowering of pump. Disconnect power to pump before doing any work on pump or attempting to remove pump from sump.

For automatic operation, plug or wire the pump into an automatic float switch or duplex controller. The pump will run continuously when plugged directly into an electrical outlet.

Connect or wire pump to its own individual branch circuit with no other outlets or equipment in the circuit. Size fuses or circuit breakers according to the "Motor, Switch and Cord Specifications" chart.

**▲ WARNING** **Risk of electrical shock and fire. Can burn, kill or cause property damage.** Be sure that power supply information (Voltage/ Hertz/Phase) on pump motor nameplate matches incoming power supply exactly. Install pump according to all electrical codes that apply.

## OPERATION

**▲ WARNING** **Risk of fire or explosion. Can cause severe personal injury, property damage or death.** Do not use in explosive atmospheres. Pump water only with this pump.

**NOTICE:** Do not allow the pump to run in a dry sump. It will void the warranty and may damage the pump.

An automatic overload protector in the motor will protect the motor from burning out due to overheating/overloading. When the motor cools down, the overload protector will automatically reset and start the motor.

If the overload trips frequently, check for the cause. It could be a stuck impeller, wrong/low voltage, or an electrical failure in the motor. If an electrical failure in the motor is suspected, have it serviced by a competent repairman.

The pump is permanently lubricated. No oiling or greasing is required.

Cycle the pump at least once every month to be sure that the system is working satisfactorily.

**NOTE: Any of the following will void the pump warranty:**

1. Submerging, plugging, damaging or taping shut a vented cord.
2. Pumping materials other than those the pump was designed to pump or continuously pumping water hotter than 120°F (49°C).
3. Cutting or splicing a power cord or switch cord.
4. Anyone other than an authorized Hydromatic service technician dismantling the pump.
5. Removing the cord tag from the cord.

## SERVICE

### General

**▲ WARNING** **Hazardous voltage and risk of cord damage. Can shock, burn, or kill.** Before removing the pump from the basin for service, always disconnect electrical power to the pump and the control switch. Do not lift the pump by the power cord. See the "Cord Lift Warning", Page 2.

### Disinfect the Pump

Place the pump in an area where it can be cleaned thoroughly. Remove all scale and deposits on the pump. Submerge the complete pump in a disinfectant solution (chlorox or chlorine bleach) for at least one hour before disassembling the pump.

The pump motor housing contains a special lubricating oil which should be kept clean and free of water at all times.

**NOTICE:** Whenever the motor housing is being removed for service, remove oil and replace it with new oil at reassembly. Use only oil listed in parts list in this manual. When filling with new oil, **DO NOT** overfill. Be sure that the oil level is 1/4" above the motor windings.

## Pump Disassembly

(See "Disinfect the Pump")

### Check Motor Windings

1. Use a quality volt-ohm-meter (VOM) when performing these inspections.
2. Set the meter to Rx1.
3. Touch both flat prongs of the power cord to the leads of the VOM and observe the readings:
  - a. 230 Volt System - 0.8 to 1.1 ohms
  - b. 115 Volt System - 1.6 to 1.8 ohms

### Check Pump Ground

4. Set the meter to Rx100
5. Touch one lead to the grounding pin and the other lead to one flat prong of the plug. Repeat for the other prong.
6. Reading should be infinity for both prongs.
  - a. If the reading is anything other than infinity, the stator must be removed, dried and rechecked.
  - b. A reading of "0" indicates a dead short. Replace the stator.

### Removing the Pump Housing

1. Remove the oil fill plug from the housing and drain the pump oil into a clean bucket. A milky appearance indicates that water has leaked into the oil. Replace O-rings and/or seals.
2. Remove the three capscrews from the upper motor housing and remove housing.

**NOTICE:** Use caution not to damage the two motor leads that are attached inside the housing.

3. Remove the two motor leads from the cord plug and set aside.

### Removing the Impeller

1. Remove the eight capscrews and separate the volute from the lower motor housing.

**NOTICE:** Loctite #277 is used to install the impeller during assembly. Break this seal to remove the impeller. Hold the shaft with a screwdriver and use a plastic or rubber mallet to tap on pump components.

2. Tap the impeller in a counterclockwise direction until it comes free of the shaft.
3. Remove the four screws and remove the top half of the volute.

### Replacing Ceramic Seal

1. Insert a screwdriver under the ceramic seal and remove it.
2. Remove the two bolts holding the stator to the seal housing.
3. Tap the shaft and rotor assembly out.

**NOTICE:** The lower ball bearing will come out with the shaft and rotor assembly.

4. Tap out the stationary half of the seal from the top of the seal plate and wipe clean.
5. Coat the replacement seal with a thin coat of dielectric oil and push the seal (carbon face out) into the seal plate with a plastic dowel. Do not damage, scratch or mar the carbon face of the seal.

## Pump Assembly

**NOTICE:** The replacement rotor must be of the same manufacture as the existing rotor.

1. Push the new rotor shaft and bearing assembly into the seal plate.
2. Fasten the stator to the seal plate with the two long capscrews.
3. Tighten the screws evenly and firmly in order to prevent any misalignment of the rotor and stator.
4. Install the seal plate on the upper volute with four flat-head screws. Be sure not to chip or scratch the seal face.
5. Coat the new ceramic rotating seal with a thin coat of dielectric oil and press it into place on the rotor shaft with the rubber ring facing the impeller.

**NOTICE:** The ceramic seal must be kept clean. Any dirt will cause the seal to fail.

6. Be sure that the shaft is clean.
7. Hold the shaft with a screwdriver and start the impeller on the shaft one or two turns.
8. Add a drop of Loctite #277 to the threads and screw the impeller on the rest of the way hand tight.

The impeller will force the ceramic seal into position.

**NOTICE:** Excessive Loctite on the seal or bearing will cause the shaft to seize.

9. Install the lower volute and fasten it securely with 8 capscrews.
10. Remove the old square-cut O-ring and install new square-cut O-ring. Avoid rolling it into position; lubricate and stretch the new square-cut O-ring to fit.
11. Fasten the motor leads inside the motor housing and tuck the wires up into the housing to prevent contact with the rotor.
12. Assemble the motor housing to the seal plate with three capscrews.
13. Check for seal leaks by pressurizing the pump to 7 to 9 PSI. If air bubbles continue, recheck seals.
14. Fill the motor housing with high-grade transformer oil (Part No. U197-8A).
15. Adjust the oil level to 1/4" (6 mm) above the motor windings top plate or to the top of the stator.

**NOTICE:** Do not fill the motor housing completely. Allow air space for expansion.

16. Replace the oil fill plug.
17. Recheck the winding resistance before applying power.
18. Plug the power cord into a grounded outlet and check the pump operation. Motor should run smoothly and be free of vibration.

## Pump Disassembly

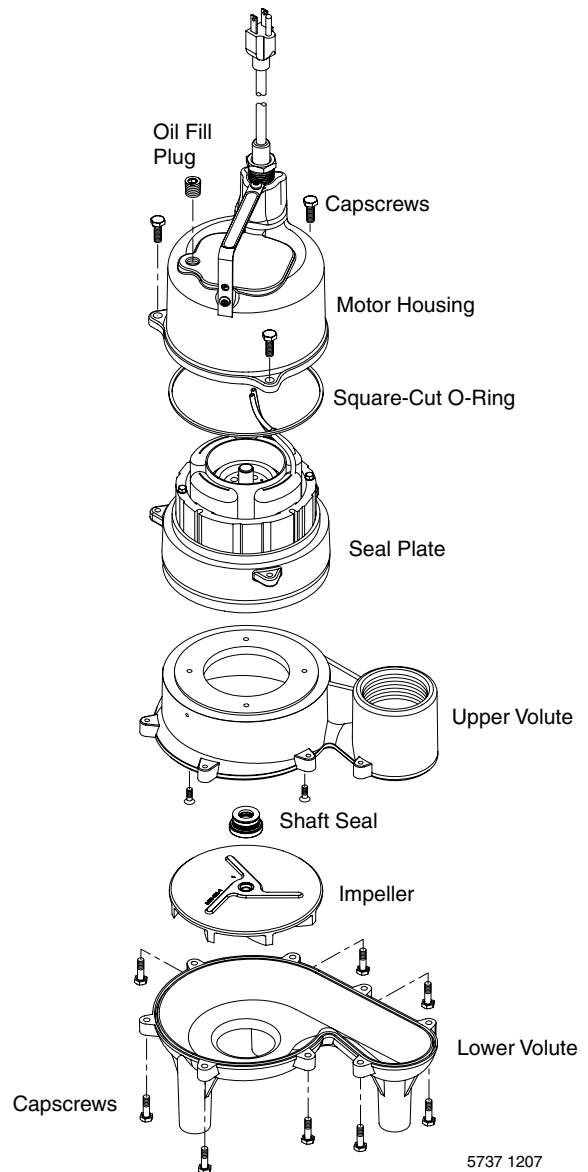

5737 1207

## EXPLODED VIEW

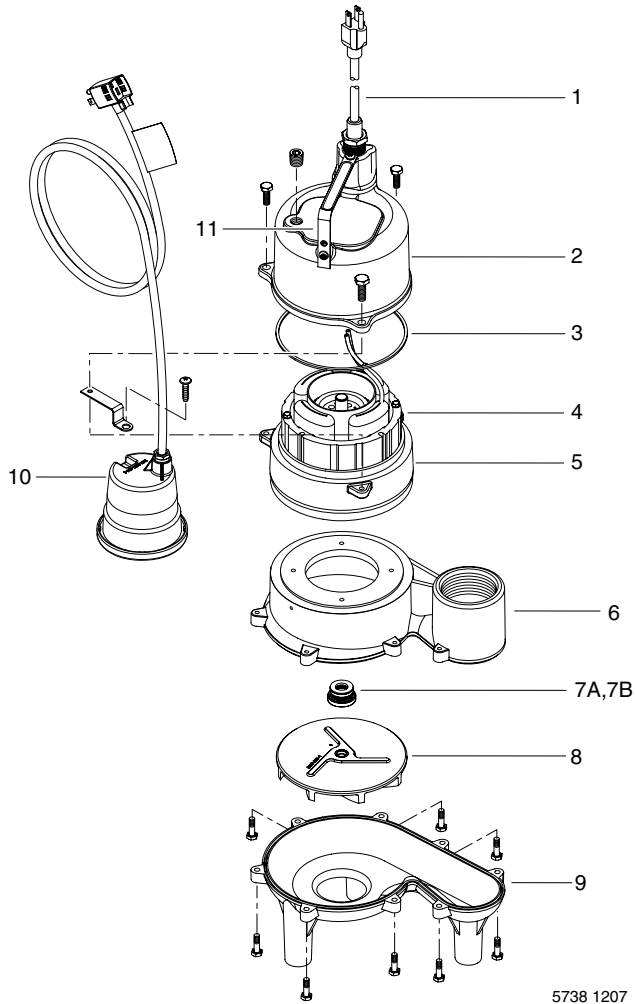

5738 1207

## REPAIR PARTS LIST

| Key No. | Part Description                  | Qty | Part Number |
|---------|-----------------------------------|-----|-------------|
| 1       | Cord 115V 10'                     | 1   | 14623-010-1 |
| 1       | Cord 115V 20'                     | 1   | 14623-020-1 |
| •       | Cord Seal Ring                    | 1   | 00139-014-1 |
| 2       | Motor Housing                     | 1   | 08507-013-5 |
| 3       | Square-Cut O-Ring                 | 1   | 00149-001-1 |
| 4       | Motor                             | 1   | *           |
| 5       | Seal Plate                        | 1   | 14599-001-2 |
| 6       | Upper Volute                      | 1   | 24637D000   |
| 7A      | Seal Half, Stationary             | 1   | 05484-001-1 |
| 7B      | Seal Half, Rotating               | 1   | 05484-003-1 |
| 8       | Impeller                          | 1   | 08498-005-1 |
| 9       | Lower Volute                      | 1   | 2468D000    |
| 10      | Diaphragm Switch, 115V 10'        | 1   | 12752-008-5 |
| 10      | Diaphragm Switch, 115V 20'        | 1   | 12752-009-5 |
| •       | Wide Angle Float Switch, 115V 10' | 1   | 12150-026-5 |
| •       | Wide Angle Float Switch, 115V 20' | 1   | 12150-023-5 |
| •       | Wide Angle Float Switch, 230V 20' | 1   | 13967-025-7 |
| 11      | Handle                            | 1   | 08522-006-3 |

\* If motor fails, replace entire pump.

• Not Illustrated

# TROUBLES-REMEDIES

**⚠ WARNING** Sudden Starts. If the power is on to the pump when thermal overload resets, the pump may start without warning. If you are working on the pump, you may get an electrical shock or the impeller may catch fingers or tools. Disconnect the power before servicing the pump.

|   |   |
|---|---|
| <p><b>A. Pump fails to operate:</b></p>   | <ol style="list-style-type: none"> <li>1. Check to be sure that power cord is securely plugged into outlet or securely wired into controller or switch box.</li> <li>2. Check to be sure you have electrical power. Be sure that the piggyback plugs are tight.</li> <li>3. Check that liquid fluid level is high enough to activate switch or controller.</li> <li>4. Check to be sure that 1/8" (3 mm) vent hole in discharge pipe is not plugged.</li> <li>5. Check for blockage in pump inlet, impeller, check valve or discharge pipe.</li> <li>6. Disconnect the pump from the power source for a minimum of 30 minutes to allow the motor to cool and to protect yourself from sudden starts. See Warning above. Check for the cause of overheating. Pump is running dry because the float switch is caught up on something. Inlet pipe is plugged. Outlet pipe is plugged.</li> <li>7. Motor windings may be open. Take unit to authorized service center.</li> </ol> |
| <p><b>B. Pump runs, but fails to empty sump:</b></p>  | <ol style="list-style-type: none"> <li>1. Be sure all valves in discharge pipe are fully open.</li> <li>2. Clean out discharge pipe and check valve.</li> <li>3. Check for blockage in pump inlet or impeller.</li> <li>4. Pump not sized properly. A higher capacity pump may be required.</li> </ol>  |
| <p><b>C. Pump will not shut off:</b></p>  | <ol style="list-style-type: none"> <li>1. Check switch for proper operation and location. See installation instructions for switch.</li> <li>2. If pump is completely inoperative or continues to malfunction, consult your local serviceman.</li> </ol>  |
| <p><b>D. Pump run but fails to deliver water:</b></p>   | <ol style="list-style-type: none"> <li>1. Check valve may be installed backwards. Be sure that the arrow on valve points in the direction of flow.</li> <li>2. Pump may be airlocked. Check vent hole in impeller housing.</li> </ol>   |
| <p><b>E. Pump fuse blows or trips circuit breaker: Motor runs for short time and stops:</b></p> | <ol style="list-style-type: none"> <li>1. Check fuse size.</li> <li>2. Intake opening clogged. Obstructed impeller. Obstructed volute.</li> <li>3. Defective stator.</li> </ol>   |
| <p><b>F. Pump runs but delivers small amount of water:</b></p>                                  | <ol style="list-style-type: none"> <li>1. Start and stop pump several times by plugging and unplugging cord.</li> <li>2. Clear vent hole in impeller cavity.</li> </ol>   |

This page intentionally left blank

## **Limited Warranty**

HYDROMATIC warrants to the original consumer purchaser ("Purchaser" or "You") of HYDROMATIC Sump Pumps, Effluent Pumps, Sewage Pumps (other than 2-1/2"), and Package Systems, that they will be free from defects in material and workmanship for the Warranty Period of 36 months from date of manufacture.

Our warranty will not apply to any product that, in our sole judgement, has been subject to negligence, misapplication, improper installation, or improper maintenance. Without limiting the foregoing, operating a three phase motor with single phase power through a phase converter will void the warranty. Note also that three phase motors must be protected by three-leg, ambient compensated, extra-quick trip overload relays of the recommended size or the warranty is void.

Your only remedy, and HYDROMATIC's only duty, is that HYDROMATIC repair or replace defective products (at HYDROMATIC's choice). You must pay all labor and shipping charges associated with this warranty and must request warranty service through the installing dealer as soon as a problem is discovered. No request for service will be accepted if received after the Warranty Period has expired. This warranty is not transferable.

EXCEPTIONS: Hydromatic Special Application Pumps, Battery Back-Up Sump Pumps, Filtered Effluent Pumps, Grinder Pumps, and 2-1/2" Sewage Pumps are warranted for a period of 12 months from date of purchase or 18 months from date of manufacture, whichever comes first.

HYDROMATIC SHALL NOT BE LIABLE FOR ANY CONSEQUENTIAL, INCIDENTAL, OR CONTINGENT DAMAGES WHATSOEVER.

THE FOREGOING LIMITED WARRANTIES ARE EXCLUSIVE AND IN LIEU OF ALL OTHER EXPRESS AND IMPLIED WARRANTIES, INCLUDING BUT NOT LIMITED TO IMPLIED WARRANTIES OF MERCHANTABILITY AND FITNESS FOR A PARTICULAR PURPOSE. THE FOREGOING LIMITED WARRANTIES SHALL NOT EXTEND BEYOND THE DURATION PROVIDED HEREIN.

Some states do not allow the exclusion or limitation of incidental or consequential damages or limitations on the duration of an implied warranty, so the above limitations or exclusions may not apply to You. This warranty gives You specific legal rights and You may also have other rights which vary from state to state.

This Limited Warranty is effective June 1, 2011 and replaces all undated warranties and warranties dated before June 1, 2011.

### **HYDROMATIC**

**293 Wright Street, Delavan, WI 53115**

**Phone: 888-957-8677 • Fax: 800-426-9446 • Web Site: [hydromatic.com](http://hydromatic.com)**