

PRE-PLUMBED SEWAGE PACKAGE

218 SERIES - SKV40

The Hydromatic 218 Packaged Sewage System for below-drain applications features the heavy-duty cast iron SKV40 series pump and corrosion-resistant basin making this the preferred package for extended service installations. The specially designed recessed vortex impeller ensures the free flow of solids up to 2" diameter.

APPLICATIONS

Residential sewage systems.



FEATURES

- ◆ **Ready To Go:** Fully assembled system includes pump, basin, sealed cover, internal basin discharge pipe, and 2" full-swing check valve.
- ◆ **Heavy-Duty Pump:** Long-life carbon/ceramic seal protects motor against leakage. Oil-filled motor for continuous lubrication and heat dissipation. Internal heat sensor prevents overheating and includes automatic reset. Tethered automatic float switch with piggyback plug.
- ◆ **Basin:** Corrosion-resistant thermoplastic construction with a 40 gallon capacity and 4" inlet hub.
- ◆ **Basin Cover:** Seal-tight thermoplastic design in thermoplastic. Discharge flange and vent flange suitable for 2" vent.

SPECIFICATIONS

- ◆ **Capacities:** 90 GPM (360 LPM)
- ◆ **Shut-Off Head:** 19' (5.8 m)
- ◆ **Solids Handling:** 2" (50.8 mm)
- ◆ **Liquids Handling:** Septic, effluent, and sewage
- ◆ **Intermittent Liquid Temperature:** Up to 140°F (60°C)
- ◆ **Motor/Electrical Data:** 4/10HP, 115V, 13A, 1Ø, 60Hz
- ◆ **Acceptable pH Range:** 5-9
- ◆ **Discharge, NPT:** 2" (50.8 mm)
- ◆ **Housing:** Heavy cast iron
- ◆ **Volute Case Cord:** Cast iron
- ◆ **Impeller:** Recessed, thermoplastic
- ◆ **Shaft Seal:** Type 11A, carbon and ceramic
- ◆ **Basin Size:** 18" x 30"; 30-gallon capacity
- ◆ **Power Cord:** 20'

HYDROMATIC PRE-PLUMBED SEWAGE PACKAGE

DIMENSIONAL DATA

Measurements shown in inches (mm).

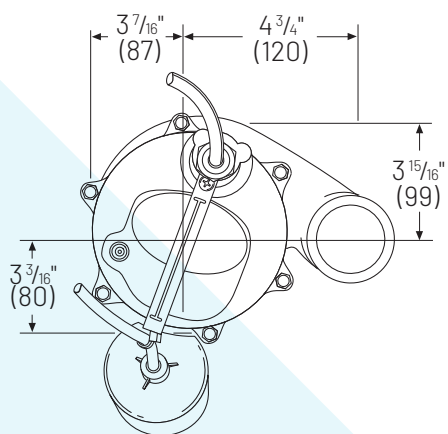
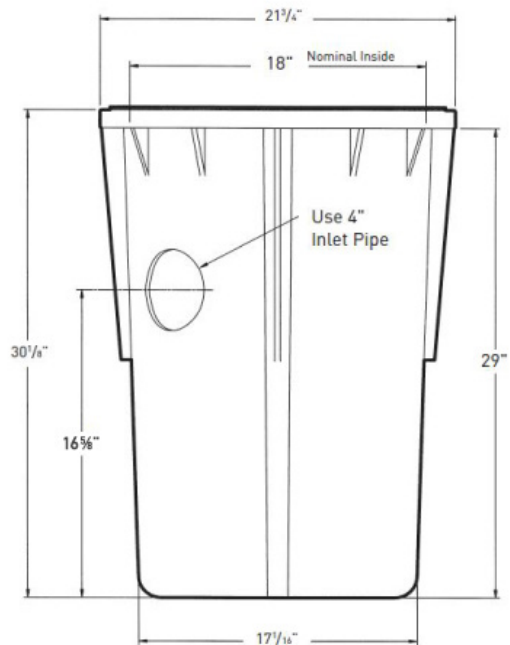
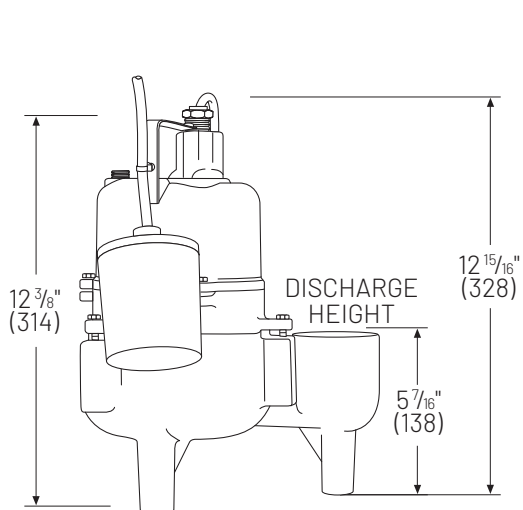

WIDE ANGLE SWITCH

On = $12-1/2"$

Off = $6-1/2"$

PERFORMANCE DATA

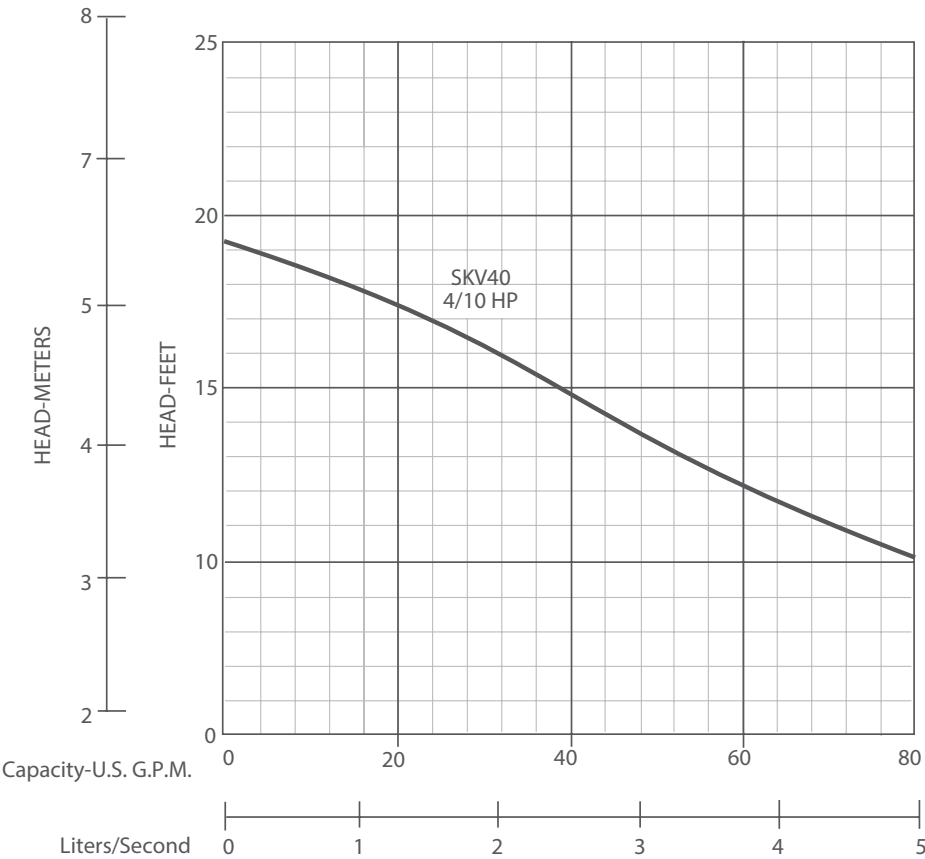

ORDERING INFORMATION

CATALOG #	HP	VOLTS	PHASE/ CYCLES	AMPS	DISCHARGE SIZE	COVER TYPE	INLET TYPE	VENT SIZE	SWITCH TYPE	CORD LENGTH	WT. LBS
218A	4/10	115	1/60	13	2"	Solid	Snap-In	2"/3"	Tethered Automatic*	20'	56

*Piggyback



293 Wright St,
 Delavan, WI 53115 USA
 Ph: 888.782.7483
 Fx: 800.426.9446

490 Pinebush Rd., Unit 4
 Cambridge, Ontario N1T 0A5, Canada
 Ph: 800.363.7867
 Fx: 888.606.5484

pentair.com

All indicated Pentair trademarks and logos are property of Pentair. Third party registered and unregistered trademarks and logos are the property of their respective owners. Because we are continuously improving our products and services, Pentair reserves the right to change specifications without prior notice. Pentair is an equal opportunity employer.