

MEDIUM PRESSURE DIAPHRAGM PUMP

9915-D303, 9915-D303GRGI, 9915-D303AP-A

FEATURES

- Hardened black oxide aluminum heads, manifold, and case.
- Three Duramax diaphragms, crown shaped pistons, and double piston rings.
- Valves: 316 stainless steel spherical profiled valve poppet.
- Inlet Port: 1"/25mm
- Outlet Port: 1/2" NPT
- Max Fluid Temp: 140°F/60°C
- Weight: 16.1 lbs/7.3 kg



PERFORMANCE INFORMATION

| PRESSURE PSI | RPM | | | | | | | |
|-----------------|-----|-----|-----|-----|-----|-----|-----|-----|
| | 400 | | 450 | | 500 | | 550 | |
| | GPM | HP | GPM | HP | GPM | HP | GPM | HP |
| 30 | 6.9 | 0.1 | 7.6 | 0.2 | 8.3 | 0.2 | 9.0 | 0.2 |
| 290 | 6.5 | 1.3 | 7.2 | 1.4 | 7.9 | 1.5 | 8.5 | 1.7 |
| 435 | 6.4 | 1.9 | 7.0 | 2.1 | 7.7 | 2.3 | 8.3 | 2.5 |
| 580 | 6.3 | 2.5 | 6.9 | 2.8 | 7.6 | 3.0 | 8.2 | 3.3 |

| PRESSURE BAR | RPM | | | | | | | |
|-----------------|------|-----|------|-----|------|-----|------|-----|
| | 400 | | 450 | | 500 | | 550 | |
| | LPM | KW | LPM | KW | LPM | KW | LPM | KW |
| 2 | 26.2 | 0.1 | 28.8 | 0.1 | 31.4 | 0.1 | 34.0 | 0.1 |
| 20 | 24.6 | 1.0 | 27.1 | 1.1 | 29.5 | 1.2 | 32.0 | 1.3 |
| 30 | 24.2 | 1.4 | 26.7 | 1.6 | 29.1 | 1.7 | 31.5 | 1.9 |
| 40 | 23.8 | 2.0 | 26.2 | 2.1 | 28.6 | 2.2 | 31.0 | 2.4 |

DIMENSIONAL DATA

9915-D303GRGI

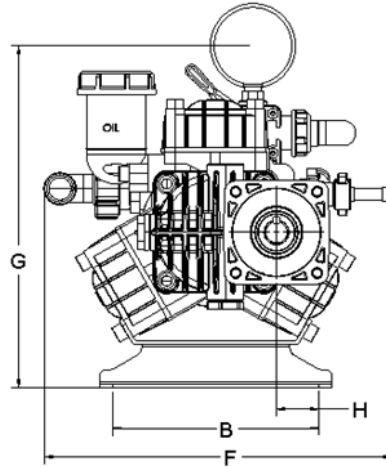
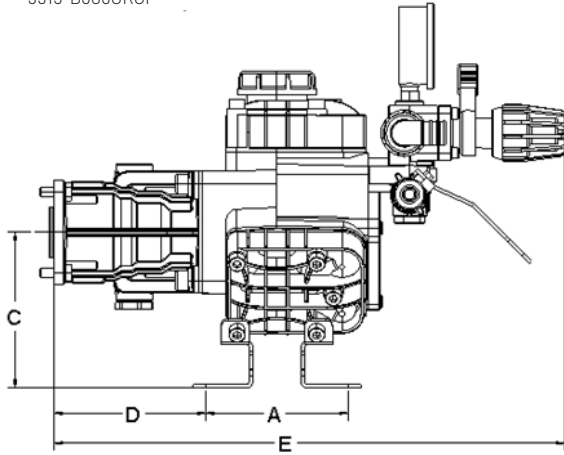

| DIM | IN | MM |
|-----|------|-----|
| A | 4.3 | 110 |
| B | 6.4 | 162 |
| C | 4.9 | 125 |
| D | 4.8 | 123 |
| E | 16.0 | 408 |
| F | 10.9 | 277 |
| G | 10.8 | 275 |
| H | 1.3 | 34 |

9915-D303, 9915-D303AP-A

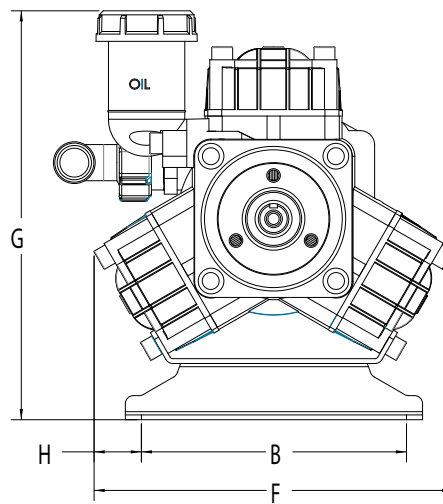
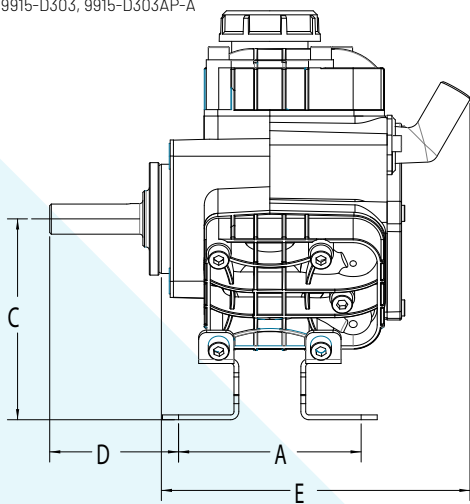

| DIM | IN | MM |
|-----|------|-----|
| A | 4.3 | 110 |
| B | 6.4 | 162 |
| C | 4.9 | 125 |
| D | 3.2 | 80 |
| E | 7.6 | 194 |
| F | 8.8 | 223 |
| G | 10.0 | 255 |
| H | 1.2 | 29 |

ORDERING INFORMATION

| MODEL NUMBER | DESCRIPTION | MAX FLOW GPM [LPM] | MAX PRESSURE PSI [BAR] | MAX SPEED RPM | POWER HP [KW] | NUMBER OF DIAPHRAGMS |
|---------------|---|--------------------|------------------------|---------------|---------------|----------------------|
| 9915-D303 | Pump Assembly | 8.1 [31] | 580 [40] | 650 | 3.2 [2.4] | 3 |
| 9915-D303GRGI | Pump Gearbox Controller 3/4" Hollow Shaft | | | 3450 | | |
| 9915-D303AP-A | Pump 3/4" Solid Shaft | | | 650 | | |
| 9915-KIT1002 | Control Unit | | | | | |
| 9915-KIT1404 | Control Unit Remote Mounting Kit | | | | | |
| 9915-KIT2002 | Diaphragm Kit | | | | | |
| 9915-KIT2102 | Valve Kit | | | | | |
| 9915-KIT2202 | Pump Kit | | | | | |
| 9915-KIT1103 | Gear Reduction Kit 3/4" Shaft | | | | | |
| 9915-KIT1201 | 3/4" Shaft Kit | | | | | |
| 9915-KIT1202 | 1" Shaft Kit | | | | | |
| 9915-KIT1203 | 1-3/8" Male Splined Shaft Kit | | | | | |



375 Fifth Ave NW,
 New Brighton, MN 55112 U.S.
 PHONE: 651-766-6300, 800-424-9776
 FAX: 800-323-6496

pentair.com

All indicated Pentair trademarks and logos are property of Pentair. Third party registered and unregistered trademarks and logos are the property of their respective owners. Because we are continuously improving our products and services, Pentair reserves the right to change specifications without prior notice. Pentair is an equal opportunity employer.

HYP2103DS (04/15/2021) ©2021 Pentair. All Rights Reserved.