

LOW PRESSURE POLY DIAPHRAGM PUMP

9915-DP2505

FEATURES

- Chemical resistant polypropylene over molded aluminum heads and manifolds.
- Five Duramax diaphragms, crown shaped pistons.
- Valves: 316 stainless steel spherical profiled valve poppet.
- Case Material: Aluminum
- Inlet Port: 2"/50 mm
- Outlet Port: 1"/25 mm
- Max Fluid Temp: 140°F/60°C
- Weight: 72.8 lbs/33 kg



PERFORMANCE INFORMATION

PRESSURE PSI	RPM							
	400		450		500		550	
	GPM	HP	GPM	HP	GPM	HP	GPM	HP
30	47.8	1.0	53.8	1.1	59.8	1.2	65.8	1.3
72	47.5	2.4	53.4	2.7	59.3	2.9	65.3	3.2
145	47.1	4.7	53.0	5.3	58.8	5.8	64.7	6.4
218	46.5	6.9	52.3	7.8	58.1	8.7	63.9	9.5

PRESSURE BAR	RPM							
	400		450		500		550	
	LPM	KW	LPM	KW	LPM	KW	LPM	KW
2	181.0	0.7	204.0	0.8	226.0	0.9	249.0	0.1
5	180.0	1.8	202.0	2.0	225.0	2.2	247.0	0.6
10	178.0	3.5	200.0	3.9	223.0	4.4	245.0	0.8
15	176.0	5.2	198.0	5.8	220.0	6.5	242.0	1.1

ORDERING INFORMATION

MODEL NUMBER	DESCRIPTION	MAX FLOW GPM [LPM]	MAX PRESSURE PSI [BAR]	MAX SPEED RPM	POWER HP [KW]	NUMBER OF DIAPHRAGMS
9915-DP2505	Pump Assembly 1-3/8" 6-Spline	63.9 [242]	218 [15]	550	9.5 [7.1]	5
9915-KIT1005	Control Unit Kit					
9915-KIT2005	Diaphragm Kit					
9915-KIT2105	Valve Kit					
9915-KIT2205	Pump Kit					
9915-KIT1301	Safety Cone					

DIMENSIONAL DATA

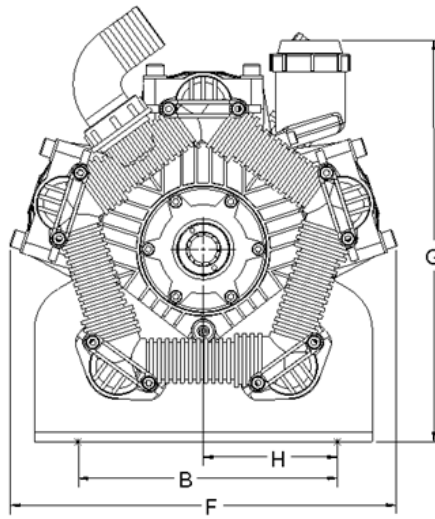
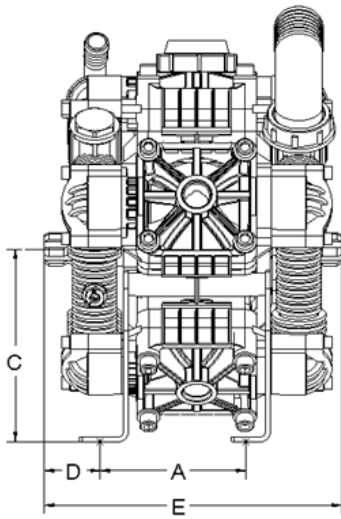

DIM	IN	MM
A	5.9	151
B	10.3	260
C	7.9	200
D	2.3	58
E	12.1	308
F	15.7	400
G	16.4	417
H	5.1	130



375 Fifth Ave NW,
New Brighton, MN 55112 U.S.
PHONE: 651-766-6300, 800-424-9776
FAX: 800-323-6496

pentair.com

All indicated Pentair trademarks and logos are property of Pentair. Third party registered and unregistered trademarks and logos are the property of their respective owners. Because we are continuously improving our products and services, Pentair reserves the right to change specifications without prior notice. Pentair is an equal opportunity employer.

HYP2107DS (04/15/2021) ©2021 Pentair. All Rights Reserved.