Installation, Operation, Repair and Parts Manual

Description

**Model 2088-343-135**

Automatic-Demand Pumps / 12 VDC

These SHURflo 2088 Series diaphragm pumps deliver reliable performance in high flow, moderate pressure applications. They are used in a variety of spot spraying, multi-tip spraying and fertilizer drip applications that require flows of up to 3.6 GPM [13.6 l/min]. They are available in a variety of chemical-resistant materials.

- Self-priming up to 12 vertical feet [3.7m]
- Chemical-resistant materials
- Can run dry without damage
- Automatic demand
- Built-in check valve (varies by model) prevents back flow of fluid into the solution tank
- Continuous duty motor on fin-cooled version

**Model 2088-343-500**

No Control - 12 VDC

These SHURflo 2088 Series diaphragm pumps deliver reliable performance in high flow, moderate pressure applications. They are used in a variety of spraying and transferring applications that require flows of up to 3.3 GPM [12.5 l/min]. They are available in a variety of chemical-resistant materials, can be mounted in any position and are designed for easy maintenance.

- Self-priming up to 12 vertical feet [3.7m]
- Chemical-resistant materials
- Can run dry without damage
- Built-in check valve (may vary by model) prevents back flow of fluid through the pump

**Model 2088-394-144**

Automatic-Demand / 115 VAC

These SHURflo 2088 Series pumps offer the same reliability as the 12 VDC version except in 115 VAC capacity. They are used in a variety of spot spraying, mini-bulk transfer and fertilizer applications that require flows of up to 3.2 GPM [12.1 l/min]. They are available in a variety of chemical-resistant materials.

- Self-priming up to 12 vertical feet [3.7m]
- Chemical-resistant materials
- Can run dry without damage
- Automatic demand
- Built-in check valve (may vary by model) prevents back flow of fluid into the solution tank

General Safety Information

NOTE

Notes are used to notify of installation, operation, or maintenance information that is important but not safety related.

CAUTION

Caution is used to indicate the presence of a hazard, which will or may cause minor injury or property damage if the notice is ignored.

WARNING

Warning denotes that a potential hazard exists and indicates procedures that must be followed exactly to either eliminate or reduce the hazard, and to avoid serious personal injury, or prevent future safety problems with the product.

DANGER

Danger is used to indicate the presence of a hazard that will result in severe personal injury, death, or property damage if the notice is ignored.

CAUTION

"Intermittent Duty" is defined as: operated and/or frequently started within a period of time that would cause the motor to reach its maximum thermal limits. Once the maximum thermal limit is obtained, the motor must be allowed to return to ambient temperature before resuming operation.

CAUTION

DO NOT use to pump flammable liquids. Never operate the pump in an explosive environment. Arcing from the motor brushes, switch or excessive heat from an improperly cycled motor may cause an explosion.

CAUTION

DO NOT assume fluid compatibility. If the fluid is improperly matched to the pumps' elastomers, a leak may occur. Pumps used to transfer hazardous or hot (max. temperature 170°F [76°C] viton only) chemicals must be in a vented area to guard against the possibility of injury due to harmful or explosive liquid/vapors.

CAUTION

DO NOT operate the pump at pressures which cause the motor to exceed the amperes rating indicated on the name plate. Various pump models are equipped with thermal breakers to interrupt operation due to excessive heat. Once the temperature of the motor is within proper limits, it will automatically reset, and the pump will start operation without warning.

CAUTION

To prevent electrical shock, disconnect power before initiating any work. In the case of pump failure, the motor housing and/or the pumped fluid may carry high voltage to components normally considered safe.

Hazardous Substance Alert

1. Always drain and flush pump before servicing or disassembling for any reason (see instructions).
2. Always drain and flush pump prior to returning unit for repair.
3. Never store pumps containing hazardous chemicals.
4. Before returning pump for service/repair, drain out all liquids and flush unit with neutralizing liquid. Then, drain the pump. Attach tag or include written notice certifying that this has been done.

NOTE

It is illegal to ship or transport any hazardous chemicals without United States Environmental Protection Agency Licensing.

Pressure Switch Operation

The pressure switch reacts to outlet pressure and interrupts power at the preset shut-off pressure indicated on the pump label. When outlet pressure drops below a pre-determined limit (typically 15-20 psi [1-1.4 bar] less than the shut-off pressure), the switch will close and the pump will operate until the shut-off (high) pressure is achieved. The shut-off pressure is set to factory calibrated standards. See the motor label for specific pump specifications.

⚠ CAUTION

Improper adjustment of the pressure switch may cause severe overload or premature failure. Failures due to

improper adjustment of the pressure switch will not be covered under the limited warranty.

If the plumbing is restrictive or the flow rate is very low, the pump may re-pressurize the outlet faster than the fluid is being released, causing rapid cycling (ON/OFF WITHIN 2 seconds). If the pump is subjected to rapid cycling during normal operation, or for infrequent periods, damage may occur. Applications which exhibit rapid cycling should have restrictions in the outlet minimized. If not feasible, consider a SHURflo accumulator or a SHURflo "bypass" model pump.

Bypass Operation

A bypass pump may be used for applications that normally induce frequent start/stop of the motor, and thereby create a potential for overheating. Models equipped with an internal bypass are designed to pump at high pressure while at low flow rates.

Bypass models equipped with a switch may operate for several seconds even though the outlet side has been closed off. Contact SHURflo for information regarding bypass pumps.

Mounting

The 2088 series pumps are self priming. Horizontal and vertical prime vary depending on the fluid viscosity and pump configuration.

The pump should be located in an area that is dry and provides adequate ventilation. If mounted within an enclosure, provisions to cool the motor may be necessary. Heat sinks, which attach to the motor, are available from SHURflo if increased heat dissipation is necessary.

⚠ CAUTION

DO NOT locate the motor near low temperature plastics or combustible materials. The surface temperature of the motor may exceed 250°F [120°C].

The pump may be mounted in any position. However, if mounting the pump vertically, the pump head should be in the down position so that in the event of a leak, fluid will not enter the motor.

Secure the rubber feet with #8 hardware. DO NOT compress the feet: doing so will reduce their ability to isolate vibration/noise.

Plumbing

Flexible high pressure tubing compatible with the fluid should be used to connect the inlet/outlet ports. Tubing should be either 3/8" or 1/2" [10 or 13 mm] I.D. and at least an 18 in. [46 cm] length is suggested to minimize stress on the fitting/ports and reduce noise. Allow for the shortest possible tubing route and avoid sharp bends that may kink over time.

NOTE

Restrictions on the inlet may cause vacuum levels to reach the fluid vapor pressure, causing cavitation,

degassing, vapor lock and a loss in performance. Inlet pressure must not exceed 30 psi [2.1 bar] maximum.

1/2" Male-threaded models are intended to be used with SHURflo swivel barb fittings which seal with an internal taper when hand-tightened. Standard 1/2" NPT fittings may be used when tightened to a maximum torque of 3.7 ft.lbs (45 in.lbs) [5 Nm].

(continued)

Plumbing (continued)

NOTE

SHURflo does not recommend the use of metal fittings or rigid pipe to plumb the inlet/outlet ports. Standard plastic male and female-threaded fittings can be acquired at commercial plumbing supply stores. SHURflo also distributes swivel barb fittings and special fittings through its dealers.

Installation of a 50-mesh strainer is recommended to prevent foreign debris from entering the pump.

If a check valve is installed in the plumbing, it must have a cracking pressure of no more than 2 psi [.14 bar].

CAUTION

Sealers and Teflon tape may act as a lubricant, causing cracked housings or stripped threads due to over-tightening. Care should be used when applying sealers. Sealers may enter the pump, inhibiting valve action, causing no prime or no shut-off. Failures due to foreign debris are not covered under warranty.

Electrical

CAUTION

Electrical wiring should be performed by a qualified electrician, in accordance with all local electrical codes.

The pump should be on a dedicated (individual) circuit, controlled with a double pole switch (U.L./C-UL certified) rated at or above the fuse ampere indicated by the pump motor label. Depending on distance of the power source from the pump and ampere load on the circuit, wire may need to be heavier than indicated by the chart.

Improper duty cycle and/or rapid start & stop conditions may cause the internal thermal breaker (if equipped) to trip, or can result in premature motor failure due to excessive heat.

For the pump to meet U.L./C-UL requirements, the circuit MUST be protected with a slow-blow fuse (U.L./C-UL certified) or equivalent circuit breaker as indicated on the motor label. Use an approved wire of the size specified or heavier.

CAUTION

All 115 VAC and 230 VAC pump motors and systems MUST be grounded per local and state electrical codes.

Voltage	Wire Leads	Wire Size	Fuse Rating
12 DC	Red (positive +) Black (negative -)	#14 AWG [2.5 Mm ²] (or heavier)	SEE PUMP
24 DC			
36 DC			
115 AC	Black (common) White (neutral) Green (ground)	#16 AWG C-UL - TEW / UL 1015 (or heavier) [1 Mm ²]	MOTOR LABEL
230 AC*	Brown (common) Blue (neutral) Green/Yellow (ground)		

*VDE requires a fuse (slow blow) or equivalent circuit breaker.

CAUTION

Circuit protection is dependent on the individual application requirements. Failure to provide proper overload/thermal devices may result in a motor failure, which will not be covered under warranty.

Troubleshooting

Symptom	Corrective Action(s)
Pump will not start:	Check fuse or breaker. Check for correct voltage ($\pm 10\%$) and electrical connections. Check pressure switch operation and correct voltage at switch or motor wires (as equipped). Check rectifier or motor for open or grounded circuit. Check for locked drive assembly.
Pump will not prime: (no discharge/motor runs)	Check to see if out of product. Check strainer for debris. Check inlet tubing/plumbing for severe vacuum leak. Check to see if inlet/outlet tubing is severely restricted (kinked). Check for debris in pump inlet/outlet valves. Check for proper voltage with the pump operating ($\pm 10\%$). Inspect pump housing for cracks.
Leaks from pump head or switch:	Check for loose screws at switch or pump head. Check to see if switch diaphragm is ruptured or pinched. Check for punctured diaphragm if fluid is present at bottom drain.
Pump will not shut off: (pressure switch equipped)	Check to see if output line is closed and no leaks. Check for air trapped in outlet line or pump head. Check for correct voltage to pump ($\pm 10\%$) Check inlet/outlet valves for debris or swelling. Check for loose drive assembly or pump head screws. Check pressure switch operation and/or if adjustment incorrect.
Noisy / rough operation:	Check mounting feet to see if they are compressed too tight. Does the mounting surface multiply noise (flexible)? Check for loose pump head or drive screws. Is the pump plumbed with rigid pipe, causing noise to transmit?

Service Kits

Kits are readily available to repair standard 2088 series pumps. Repair kits include simple illustrated instructions allowing easy installation. To ensure that the correct kit is received, the model number and all name plate data must be included with the order. Contact a SHURflo distributor or SHURflo directly to order the necessary repair kit.

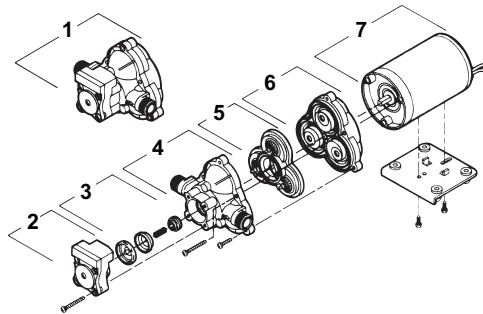

Model Number	1 Complete Pump head Assembly	2 Switch Assembly	3 Check Valve Assembly	4 Upper Housing	5 Bypass/Non Bypass Valve Assembly	6 Drive/Impeller Diaphragm Assembly	7 Motor
2088-313-145	94-286-15	94-230-55	94-237-05	94-231-30	94-232-05	94-238-03	11-185-06
2088-343-135	94-236-11	94-230-36	94-237-05	94-231-30	94-232-05	94-238-03	11-111-00
2088-343-170	N/A	N/A	N/A	94-231-40	94-232-05	94-238-03	11-174-01
2088-343-500	N/A	N/A	N/A	94-231-40	94-232-05	94-238-03	11-111-00
2088-394-144	N/A	N/A	94-237-00	94-231-30	94-232-05	94-238-03	11-195-01
2088-394-154	94-236-11	94-230-36	94-237-05	94-231-30	94-232-05	94-238-03	11-150-10

Notes

Limited Warranty on Hypro/SHURflo Agricultural Pumps & Accessories

Hypro/SHURflo (hereafter, "Hypro") agricultural products are warranted to be free of defects in material and workmanship under normal use for the time periods listed below, with proof of purchase.

- Pumps: one (1) year from the date of manufacture, or one (1) year of use. This limited warranty will not exceed two (2) years, in any event.
- Accessories: ninety (90) days of use.

This limited warranty will not apply to products that were improperly installed, misapplied, damaged, altered, or incompatible with fluids or components not manufactured by Hypro. All warranty considerations are governed by Hypro's written return policy.

Hypro's obligation under this limited warranty policy is limited to the repair or replacement of the product. All returns will be tested per Hypro's factory criteria. Products found not defective (under the terms of this limited warranty) are subject to charges paid by the returnee for the testing and packaging of "tested good" non-warranty returns.

No credit or labor allowances will be given for products returned as defective. Warranty replacement will be shipped on a freight allowed basis. Hypro reserves the right to choose the method of transportation.

This limited warranty is in lieu of all other warranties, expressed or implied, and no other person is authorized to give any other warranty or assume obligation or liability on Hypro's behalf. Hypro shall not be liable for any labor, damage or other expense, nor shall Hypro be liable for any indirect, incidental or consequential damages of any kind incurred by the reason of the use or sale of any defective product. This limited warranty covers agricultural products distributed within the United States of America. Other world market areas should consult with the actual distributor for any deviation from this document.

Return Procedures

All products must be flushed of any chemical (ref. OSHA section 1910.1200 (d) (e) (f) (g) (h)) and hazardous chemicals must be labeled/tagged before being shipped* to Hypro for service or warranty consideration. Hypro reserves the right to request a Material Safety Data Sheet from the returnee for any pump/product it deems necessary. Hypro reserves the right to "disposition as scrap" products returned which contain unknown fluids. Hypro reserves the right to charge the returnee for any and all costs incurred for chemical testing, and proper disposal of components containing unknown fluids. Hypro requests this in order to protect the environment and personnel from the hazards of handling unknown fluids.

Be prepared to give Hypro full details of the problem, including the model number, date of purchase, and from whom you purchased your product. Hypro may request additional information, and may require a sketch to illustrate the problem.

Contact Hypro Service Department at 800-468-3428 to receive a Return Merchandise Authorization number (RMA#). Returns are to be shipped with the RMA number clearly marked on the outside of the package. Hypro shall not be liable for freight damage incurred during shipping. Please package all returns carefully. All products returned for warranty work should be sent **shipping charges prepaid** to:

HYPRO
Attention: Service Department
375 Fifth Avenue NW
New Brighton, MN 55112

For technical or application assistance, call the **Hypro Technical/Application number: 800-445-8360**, or send an email to: **technical@hypropumps.com**. To obtain service or warranty assistance, call the **Hypro Service and Warranty number: 800-468-3428**; or send a fax to the **Hypro Service and Warranty FAX: 651-766-6618**.

*Carriers, including U.S.P.S., airlines, UPS, ground freight, etc., require specific identification of any hazardous material being shipped. Failure to do so may result in a substantial fine and/or prison term. Check with your shipping company for specific instructions.

