

Installation, Operation, Repair, and Parts Manual**Description**

Hypro polypropylene-headed diaphragm pumps are recommended for spraying herbicides, pesticides, liquid fertilizers, and many other hard-to-handle fluids. The specially designed inlet manifolds, outlet manifolds, and heads are all polypropylene construction for the maximum in chemical resistance. Low-cost maintenance and almost wear-free operation make these pumps ideal for a wide variety of spraying jobs. Pressure and output are designed for optimum performance of small to medium sized sprayers.

These pumps feature valves of Kynar and 304 stainless steel construction for excellent wear life and independence modular inlet and outlet manifolds for easy maintenance. Hypro polypropylene-headed diaphragm pumps can be adapted for 1-3/8" 6 splined shaft, 1" solid shaft, or gear reduction drive options.



Model 9910-DP423
Model 9910-DP423GRGI
Max flow: 11 gpm
Max pressure: 290 psi (20 bar)
Max speed: 550 rpm (D423)
3600 rpm (D423GRGI)
3 diaphragms

Model 9910-DP573
Model 9910-DP573GRGI
Max flow: 15 GPM
Max pressure: 290 psi (20 bar)
Max speed: 550 rpm (DP573)
3 diaphragm

Model 9910-DP763
Model 9910-DP763GRGI
Max flow: 20 GPM
Max pressure: 290 psi (20 bar)
Max speed: 550 rpm (DP573)
3 diaphragm

General Safety Information

NOTE

Notes are used to notify of installation, operation, or maintenance information that is important but not safety related.

CAUTION

Caution is used to indicate the presence of a hazard, which will or can cause minor injury or property damage if the notice is ignored.

WARNING

Warning denotes that a potential hazard exists and indicates procedures that must be followed exactly to either eliminate or reduce the hazard, and to avoid serious personal injury, or prevent future safety problems with the product.

DANGER

Danger is used to indicate the presence of a hazard that will result in severe personal injury, death, or property damage if the notice is ignored.

DANGER

- Do not pump flammable or explosive fluids such as gasoline, fuel oil, kerosene, etc. Do not use in explosive atmospheres. Do not pump asphalt sealer, roofing compounds, concrete sealers, or any two-step curing products. The pump should only be used with liquids compatible with the pump materials. Failure to follow this notice can result in severe personal injury and/or property damage and will void the product warranty.
- Never use your hand to check the condition of hydraulic lines or hoses. If hydraulic fluid penetrates the skin, get medical attention immediately. Failure to get proper medical attention may result in loss of limb or life. The safest way to check hydraulic lines is by holding a piece of cardboard next to the hydraulic line or hose.

WARNING

- The sound pressure level of the pump may exceed 80dBA. Observe all safety precautions when operating the pump within close proximity for extended periods by wearing hearing protectors. Extended exposure to elevated sound levels will result in permanent loss of hearing acuteness, tinnitus, tiredness, stress, and other effects such as loss of balance and awareness.
- Verify that pump shaft rotates freely prior to engaging the pump drive.

CAUTION

- Do not pump at pressures higher than the maximum recommended pressure.
- Operate the pump between a temperature range of 45° to 140° F [7° to 60° C].
- Make certain that the power source conforms to the requirements of your equipment.
- Provide adequate protection in guarding around the moving parts such as shafts and pulleys.
- Disconnect the power before servicing.
- Release all pressure within the system before servicing any component.
- Drain all liquids from the system before servicing.
- Secure the discharge line before starting the pump. An unsecured discharge line may whip, resulting in personal injury and/or property damage.
- Check all hoses for weak or worn condition before each use. Make certain that all connections are tight and secure.
- Periodically inspect the pump and the system components. Perform routine maintenance as required (see maintenance).
- When wiring an electrically driven pump, follow all electrical and safety codes, as well as the most recent National Electrical Code (NEC) and the Occupational Safety and Health Act (OSHA) requirements.
- Use only pipe, hose, and hose fittings rated for maximum rated pressure of the pump or the pressure at which the pressure relief valve is set at. Do not use used pipe.
- Do not use these pumps for pumping water or other liquids for human or animal consumption.
- Do not pressure feed pump inlet.

Hazardous Substance Alert

CAUTION

- Always drain and flush pump before servicing or disassembling for any reason (see instructions).
- Always drain and flush pumps prior to returning unit for repair.
- Never store pumps containing hazardous chemicals.
- Before returning pump for service/repair, drain out all liquids and flush unit with neutralizing liquid. Then, drain the pump. Attach tag or include written notice certifying that this has been done. Please note that it is illegal to ship or transport any hazardous chemicals without United States Environmental Protection Agency Licensing.

Installation

Pump Plumbing

NOTE

Use only pipe, fittings, accessories, hose, etc. rated for the maximum pressure rating of the pump.

1. Always mount pump with oil sight tube in upright position (See Figure A).
2. The proper selection of hose type and size is vital to optimal performance.
 - a. Use good quality inlet hose, compatible with the fluids being pumped and with good elasticity to reduce inlet water hammer or pulsation. Be sure that hose is not too rigid but capable of operating at low vacuums without collapsing. The diameter of the inlet hose should be at least that of the pump inlet port size and preferably one size larger if the inlet line is longer than 6 feet [1.8 meters].
 - b. Use only approved high pressure hose on the discharge side of pump.
3. Most ports are provided with hose barb connections. Use good quality hose clamps and tighten them securely.

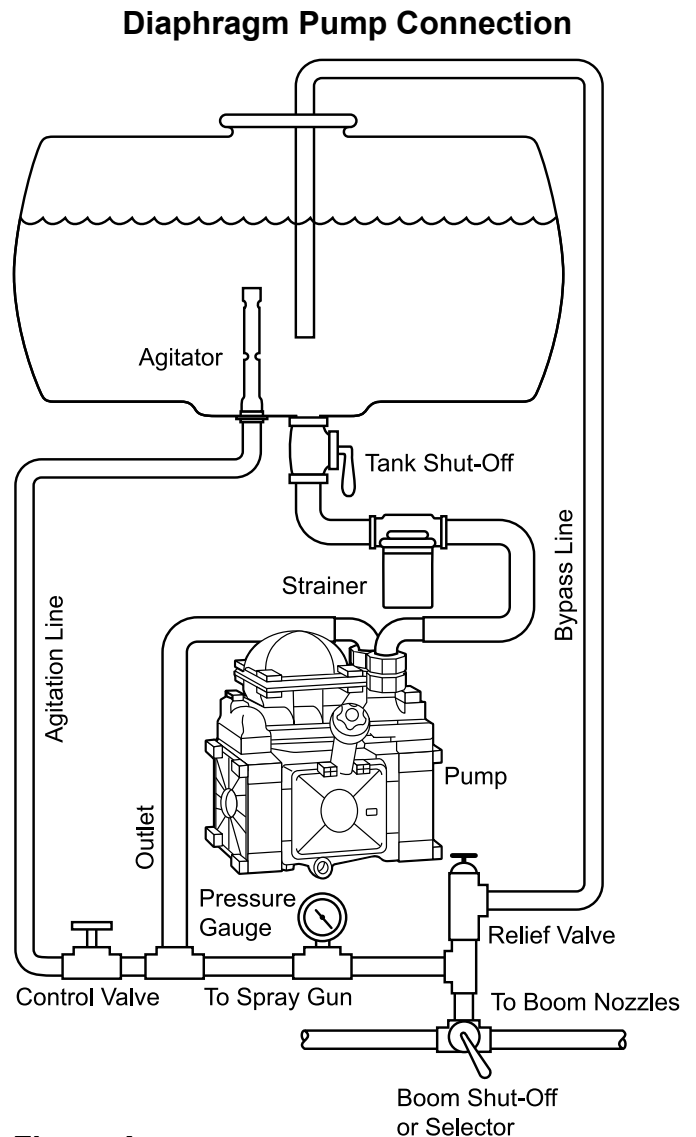
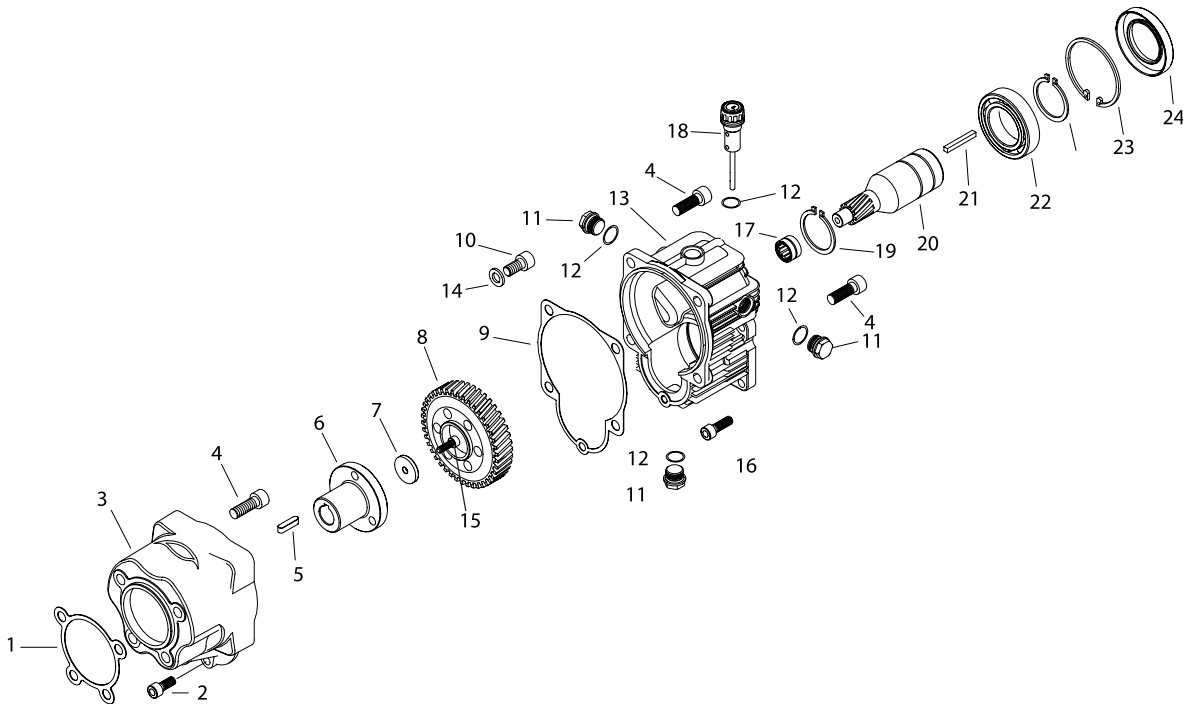

Figure A

Installation Instructions for Gear Reduction Kit 9910-KIT31086



NOTE

Hypro recommends a blue thread locking compound on all threaded fasteners that do not require lock washers. Shaft key needs to be inspected occasionally and replaced if worn.

The 9910-KIT31086 gear reducer is designed for direct mounting the 9910-DP423, 9910-DP523 & 9910-DP763 diaphragm pump onto a 5 hp gasoline engine with a flange mounting and 3/4" solid shaft.

1. Lubricate the gasket (Ref. 1) in the pump adapter flange (Ref. 3). Slip the flange over the machined surface of the casting, shaft end of pump. Install (4) mounting bolts (Ref. 4) through the adapter flange into the pump body.
2. Install the shaft hub (Ref. 6) on the pump shaft, after inserting the key (Ref. 5). Secure the hub by threading the retaining bolt (Ref. 15) through the retaining washer (Ref. 7) into the pump shaft.
3. Install the pump gear (Ref. 8) with the pilot diameter of the gear inserted into the inner diameter of the pump shaft. Secure firmly onto the shaft using M10 x 25 socket head cap screws (Ref. 10) and lock washers (Ref. 14).
4. Align the holes in the pump adapter flange (Ref. 3) with threaded holes in the pump body. Lubricate the gasket (Ref. 9) and place it in position on the gearbox body (Ref. 13). Install the gearbox body (Ref. 13) on the pump adapter flange (Ref. 3) and secure firmly with M10 x 75 socket head cap screws (Ref. 4). Install the M8 x 20 socket head cap screw (Ref. 2) and tighten securely.
5. Insert the long key (Ref. 21) into the engine shaft keyway. Align the keyway in the gear reducer input shaft (Ref. 20) and slide the pump and gear reducer onto the engine shaft.
6. Align the holes in the gearbox body (Ref. 13) with threaded holes in engine boss. Insert 5/16"x1"-24 socket head cap screws through the gearbox body (Ref. 13) and thread them into the threaded holes in the engine boss. Securely tighten with the hex wrench provided.
7. The vent plug (Ref. 18) must always be installed or reinstalled in the uppermost threaded hole of the gearbox body (Ref. 13). Plugs (Ref. 11) and vent plug (Ref. 18) are interchangeable for gear reducer mounting convenience.
8. Fill the gear case with 90W gear lube. To properly fill, first tighten the bottom plug (Ref. 11); then remove one side plug (Ref. 11) and the vent plug (Ref. 18). Fill until the gear lube is no higher than the mark on the dipstick.
9. Replace and tighten the side plug and the vent plug.
10. Please apply anti-seize to the motor shaft prior to installing the gearbox.

Control Unit 9910-GS25

The 9910-GS25 control unit is designed for convenient control of pressures up to 290 psi and flows up to 12 gpm. It consists of an adjustable pressure relief valve, a manual pressure release lever, and two individual ball valve-controlled 1/2" hose barb outlets. It can be direct mounted onto the 9910-DP423 discharge manifold.

NOTE

Hypro recommends a blue thread locking compound on all threaded fasteners that do not require lock washers.

1. Locate the discharge manifold on the 9910-DP423, 9910-DP573 & 9910-DP763 (Ref. 68). With o-rings (Ref. 53) lubricated and in position on control valve body (Ref. 52), plug into discharge manifold. Lock into place with retainer clip (Ref. 60).
2. Connect bypass hose to elbow (Ref. 45) and run unrestricted to supply tank.
3. Connect the desired number of high pressure hoses to the outlet hose barbs. Unused hose barbs can be shut off with ball valves provided.

NOTE

For all discharge hoses, use hose with an operating pressure rating equal to or greater than the maximum pressure rating of the pump. High pressure clamping should be used on all outlet hose connections.

NOTE

Hypro recommends a blue thread locking compound on all threaded fasteners that do not require lock washers.

1. Install mounting bracket (Ref. 15) in desired location and secure with bolts (Ref. 12), washers (Ref. 13) and nuts (Ref. 14); then attach the control to the bracket.

▲ WARNING

Always wear safety goggles when working with spring-loaded fasteners or devices.

2. With o-rings (Ref. 35) lubricated and in position on the control valve body (Ref. 26), plug it into the inlet adapter (Ref. 5); then lock it into place with retaining clip (Ref. 28).
3. Connect the NPT fitting on the discharge manifold of the pump with the NPT fitting on the control unit with the high pressure hose.
4. Connect the bypass hose to the elbow (Ref. 11), then run it unrestricted to the supply tank.
5. Connect the desired number of high pressure hoses to the outlet hose barbs on the control valve. Unused hose barbs can be shut off with ball valves provided.

For all discharge hoses, use hose with an operating pressure rating equal to or greater than the maximum pressure rating of the pump. High pressure clamping should be used on all outlet hose connections.

Operating Instructions

1. Be sure oil is halfway up to the clear oil sight tube. If necessary, fill to the correct level with Hypro oil (part number 2160-0038). Hypro oil is a specially formulated, high-grade, non-detergent, SAE 30 weight oil formulated to prolong pump life.
2. Make sure the suction hose barb is tightly screwed onto the suction union and that there are no air leaks on the inlet side of the pump.
3. The relief valve bypass port should be connected back to the liquid tank without restrictions. Do not hook bypass line back to the inlet port or inlet hose.
4. Allow the pump to start under low pressure by removing restrictions on the outlet of the pump.
5. Start the pump and let it run for approximately one minute at low pressure; then stop the pump and check the oil level in the sight glass. Add Hypro oil if necessary.
6. Adjust the pump to the desired pressure by changing the relief valve setting on the control unit, relief valve or unloader.

Set the pressure control to the pressure setting; then rotate the pressure regulator to the desired pressure.

Maintenance Instructions

1. After usage, flush the pump with clean water.
2. Hypro diaphragm pumps come with oil in the crankcase. Hypro recommends changing oil after 40 hours of break-in operation and every three months or 500 hours, whichever comes first. Use Hypro oil (part number 2160-0038). Hypro oil is a specially formulated, high-grade, non-detergent, SAE 30 weight oil formulated to prolong pump life.



To drain the oil:

Remove the drain plug (2406-0023) and the oil sight glass covers, and rotate shaft until the oil stops flowing out. Re-install the drain plug.

To fill the pump with oil, slowly pour oil into sight tube while turning the pump shaft. Turning the pump shaft purges all the air out of the crankcase. Always change oil when replacing diaphragms.

3. For winter storage or if a freezing condition will be encountered, flush the pump with a 50/50 mixture of water and antifreeze.

⚠ CAUTION

The bypass return outlet on all control units must be connected directly to the tank without restrictions or ball valves.

CRANKCASE OIL CAPACITIES	
Model	Capacity
9910-DP423	13 oz.
9910-DP573	
9910-DP763	

Oil crankcase capacities are approximate. Fill oil to proper level in sight glass. Always make sure all the air is purged out of crankcase prior to operation.

Valve Replacement

Occasionally debris may cause improper seating of the valves or damage to the o-rings. To check for this problem, follow these steps.

Inlet Manifold:

1. Using a 13 mm socket, remove (9) manifold mounting bolts (Fig. 1). **DO NOT USE IMPACT GUN ON MOUNTING BOLTS.**
2. Pull or gently pry away the manifold from the pump heads (Fig. 2). Do this so the valve pilots are completely free from the pump heads.
3. On gear reduction or pulley-driven models, there may not be enough room to access the valves for service while the manifold remains in one piece. To split the manifold, either pull or gently pry apart at opposing joints as shown in Figures 3 and 4.
4. Remove the suction valves for service or replacement. This can usually be done by hand, but use external pliers (as shown in Fig. 5) if necessary.



Fig. 1



Fig. 2



Fig. 3



Fig. 4

Discharge Manifold:

1. Using a 13 mm socket, remove (9) manifold mounting bolts. DO NOT USE IMPACT GUN ON MOUNTING BOLTS.
2. Pull or gently pry away the manifold from the pump heads (Fig. 6). Do this so the valve pilots are completely free from the pump heads.
3. It should not be necessary to split the manifold to access the valves as was done with the inlet manifold.
4. Remove the discharge valves for service or replacement. This can usually be done by hand (Fig. 7) but use external pliers if necessary.



Fig. 5



Fig. 6



Fig. 7

Diaphragm Replacement

Change diaphragms every 500 hours or three months, whichever comes first.

1. Drain oil from crankcase as instructed previously.
2. Remove pump head bolts and heads (See Figure 8). DO NOT USE IMPACT GUN ON HEAD BOLTS.
3. Remove the bolt securing the diaphragm (See Figure 9).
4. Remove the old diaphragm and the washer (See Figures 10 and 11).
5. Install a new diaphragm; then turn the crankshaft to bring the piston to its down-stroke and seat the diaphragm into the sleeve groove.
6. Install the washer and bolts removed in steps 3 and 4. Reference torque specs on page 13.
7. Refill the crankcase with Hypro oil (part number 2160-0038). Rotate the shaft to distribute the oil, and fill to proper level.



Fig. 8



Fig. 9



Fig. 10



Fig. 11

Hazardous Substance Alert Maintenance Schedule

REGULAR SERVICE PERIOD Performed at every indicated month or operating hour interval, whichever comes first.		First Use	Each Use	First month or 40 hours	Every 3 months or 500 hours	Every 6 months or 1000 hours
Item						
Crankcase Oil	Check Level	X	X			
	Replace			X	X	
Gearbox Oil	Check Level	X	X			
	Replace			X	X	
Pulsation Dampener Pressure (in models with dampeners)	Set to 20% of working PSI	X				
	Check			X	X	
Diaphragms	Replace				X	
Valves	Check				X	
	Replace					X
O-rings	Check				X	
	Replace					X

PERFORMANCE CHARTS

DP 423										
Pressure in PSI and BAR	GPM	HP	GPM	HP	GPM	HP	GPM	HP	GPM	HP
	LPM	HP	LPM	HP	LPM	HP	LPM	HP	LPM	HP
	@ 350 RPM		@ 400 RPM		@ 450 RPM		@ 500 RPM		@ 550 RPM	
0 PSI	7.5	0.18	8.5	0.20	9.4	0.29	10.5	0.35	11.5	0.42
0 BAR	28.3	0.18	32.2	0.20	35.6	0.29	39.5	0.35	43.3	0.42
72 PSI	7.3	0.46	8.3	0.53	9.2	0.61	10.2	0.68	11.0	0.77
5 BAR	27.4	0.46	31.2	0.53	34.6	0.61	38.5	0.68	41.5	0.77
145 PSI	7.2	0.77	8.2	0.87	9.1	0.98	10.1	1.11	11.0	1.21
10 BAR	27.3	0.77	31.1	0.87	34.5	0.98	38.2	1.11	41.4	1.21
217 PSI	7.0	1.06	8.1	1.21	9.1	1.37	10.0	1.51	10.8	1.68
15 BAR	26.5	1.06	30.5	1.21	34.5	1.37	37.7	1.51	40.7	1.68
290 PSI	6.9	1.33	7.8	1.53	9.1	1.74	9.8	1.93	10.6	2.14
20 BAR	26.0	1.33	29.5	1.53	34.2	1.74	37.0	1.93	40.1	2.14

DP 573										
Pressure in PSI and BAR	GPM	HP	GPM	HP	GPM	HP	GPM	HP	GPM	HP
	LPM	KW	LPM	KW	LPM	KW	LPM	KW	LPM	KW
	@ 350 RPM		@ 400 RPM		@ 450 RPM		@ 500 RPM		@ 550 RPM	
0 PSI	10.4	0.14	11.7	0.17	13.0	0.24	14.3	0.32	15.6	0.43
0 BAR	39.5	0.10	44.3	0.13	49.1	0.18	54.3	0.24	59.1	0.32
72 PSI	10.3	0.54	11.6	0.62	12.6	0.67	14.2	0.77	15.5	0.83
5 BAR	39.0	0.40	43.8	0.46	47.7	0.50	53.9	0.57	58.6	0.62
145 PSI	10.1	0.95	11.4	1.09	12.6	1.22	14.1	1.28	15.2	1.41
10 BAR	38.4	0.71	43.0	0.81	47.6	0.91	53.3	0.95	57.5	1.05
217 PSI	9.9	1.33	11.1	1.50	12.5	1.71	13.9	1.89	14.9	2.07
15 BAR	37.3	0.99	41.9	1.12	47.4	1.28	52.7	1.41	56.4	1.54
290 PSI	9.7	1.60	10.8	1.88	12.5	2.14	13.8	2.43	14.8	2.64
20 BAR	36.8	1.19	40.9	1.40	47.3	1.60	52.3	1.81	56.1	1.97

DP 763										
Pressure in PSI and BAR	GPM	HP	GPM	HP	GPM	HP	GPM	HP	GPM	HP
	LPM	KW	LPM	KW	LPM	KW	LPM	KW	LPM	KW
	@ 350 RPM		@ 400 RPM		@ 450 RPM		@ 500 RPM		@ 550 RPM	
0 PSI	13.7	0.20	15.3	0.29	17.1	0.39	18.8	0.51	20.2	0.63
0 BAR	51.8	0.15	57.8	0.22	64.9	0.29	71.0	0.38	76.4	0.47
72 PSI	13.4	0.71	15.2	0.77	16.8	0.90	18.4	0.98	20.1	1.11
5 BAR	50.9	0.53	57.6	0.57	63.5	0.67	69.8	0.73	76.0	0.83
145 PSI	13.3	1.21	15.0	1.39	16.7	1.58	18.4	1.76	19.9	1.93
10 BAR	50.5	0.90	56.8	1.04	63.4	1.18	69.7	1.31	75.4	1.44
217 PSI	12.8	1.76	14.9	2.02	16.7	2.25	18.1	2.50	19.5	2.75
15 BAR	48.5	1.31	56.3	1.51	63.1	1.68	68.6	1.86	73.9	2.05
290 PSI	12.7	2.12	14.6	2.49	16.5	2.77	18.0	3.12	19.4	3.45
20 BAR	48.0	1.58	55.4	1.86	62.3	2.07	68.2	2.33	73.4	2.57

Hydraulic Motor Kit 9910-KIT55375

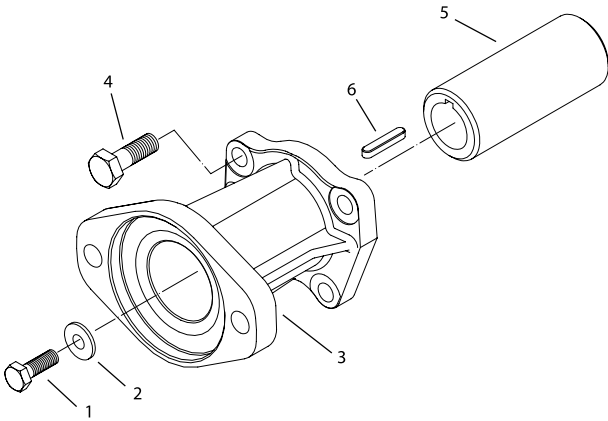

Ref. No.	Part Number	Description	Qty
1	9910-740450	Bolt	1
2	9910-391470	Washer	1
3	9910-3120700	Hydraulic Motor Flange	1
4	9910-620320	Bolt	4
5	9910-3120780	Hydraulic Motor Joint D 1"	1
6	9910-2280950	Key	1

Ref. No.	Description	Tightening Torque	
		In. Lbs.	Nm.
1	Bolt	221	25
4	Bolt	221	25

Pulley Mounting Kit 9910-KIT42610

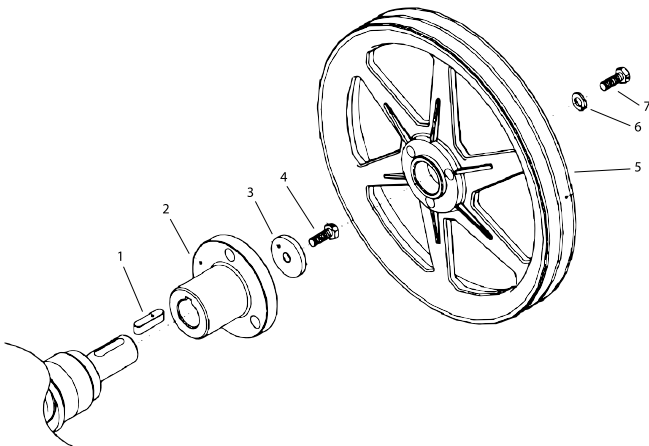

Ref. No.	Part Number	Description	Qty
1	9910-2280950	Key (AP-A Model)	1
2	9910-3120350	Pulley Joint	1
3	9910-780230	Retainer Washer	1
4	9910-740450	Bolt	1
5	9910-620280	Pulley	1
6	9910-200231	Washer	3
7	9910-160670	Bolt	3

Ref. No.	Description	Tightening Torque	
		In. Lbs.	Nm.
4	Bolt	221	25
7	Bolt	177	20

Pulley Dia.: 11"	
Drive Source RPM	Drive Source Pulley Dia.
1160	5-1/4"
1725	3-1/2"
3450	Not Recommended

Gearbox 9910-KIT31086

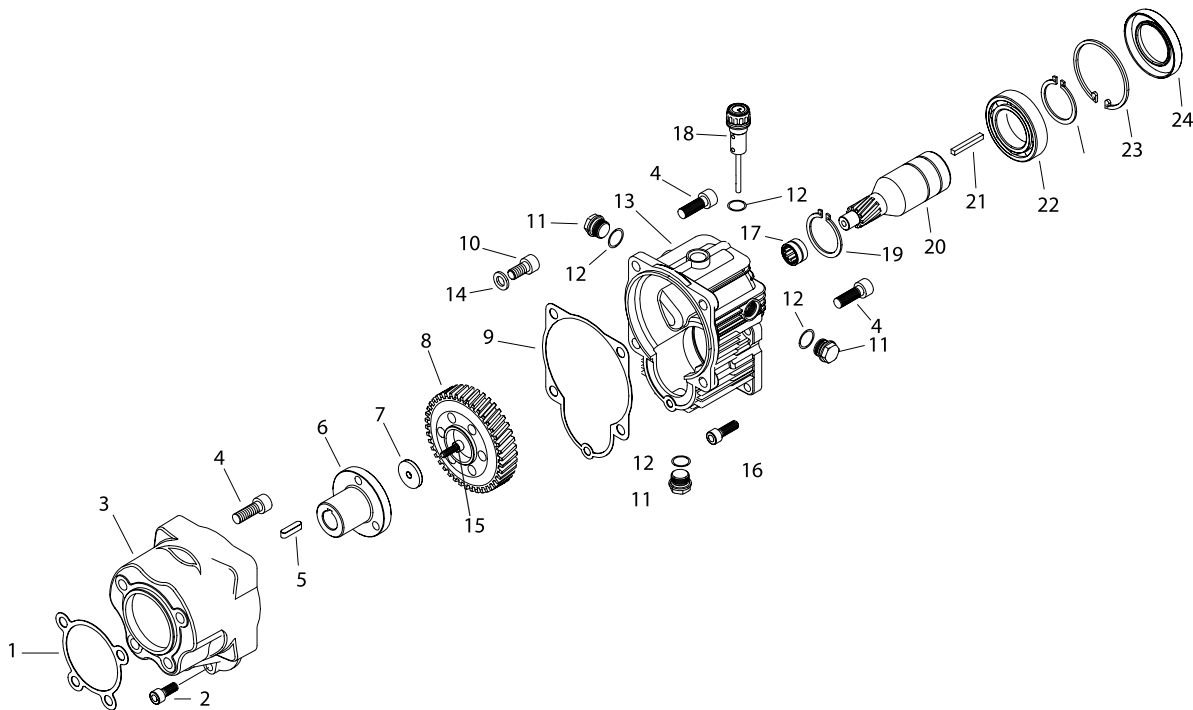

Ref. No.	Part Number	Description	Qty.
1	9910-3120360	Gasket	1
2	9910-180030	Bolt	1
3	9910-3120340	Gearbox Flange	1
4	9910-540300	Bolt	8
5	9910-2280950	Key	1
6	9910-3120350	Gear Hub	1
7	9910-780230	Washer	1
8	9910-651620	Gear	1
9	9910-620950	Gasket	1
10	9910-620470	Bolt	3
11	9910-1980740	Plug	3
12	9910-740290	O-ring	3
13	9910-620960	Gear Box Housing	1
14	9910-200231	Washer	3
15	9910-880280	Bolt	1
16	9910-651000	Bolt	4
17	9910-620990	Bearing	1
18	9910-1140370	Plug	1
19	9910-320240	Retainer Ring	2
20	9910-621660	Pinion Gear - 3/4" shaft only	1
21	9910-881090	Key	1
22	9910-961780	Bearing	1
23	9910-961790	Retaining Ring	1
24	9910-961800	Seal	1

Ref. No.	Description	Tightening Torque	
		In. Lbs.	Nm.
2	Bolt	221	25
4	Bolt	221	25
10	Bolt	177	20
11	Plug	177	20
15	Bolt	221	25
16	Bolt	221	25

Model 9910-GS25

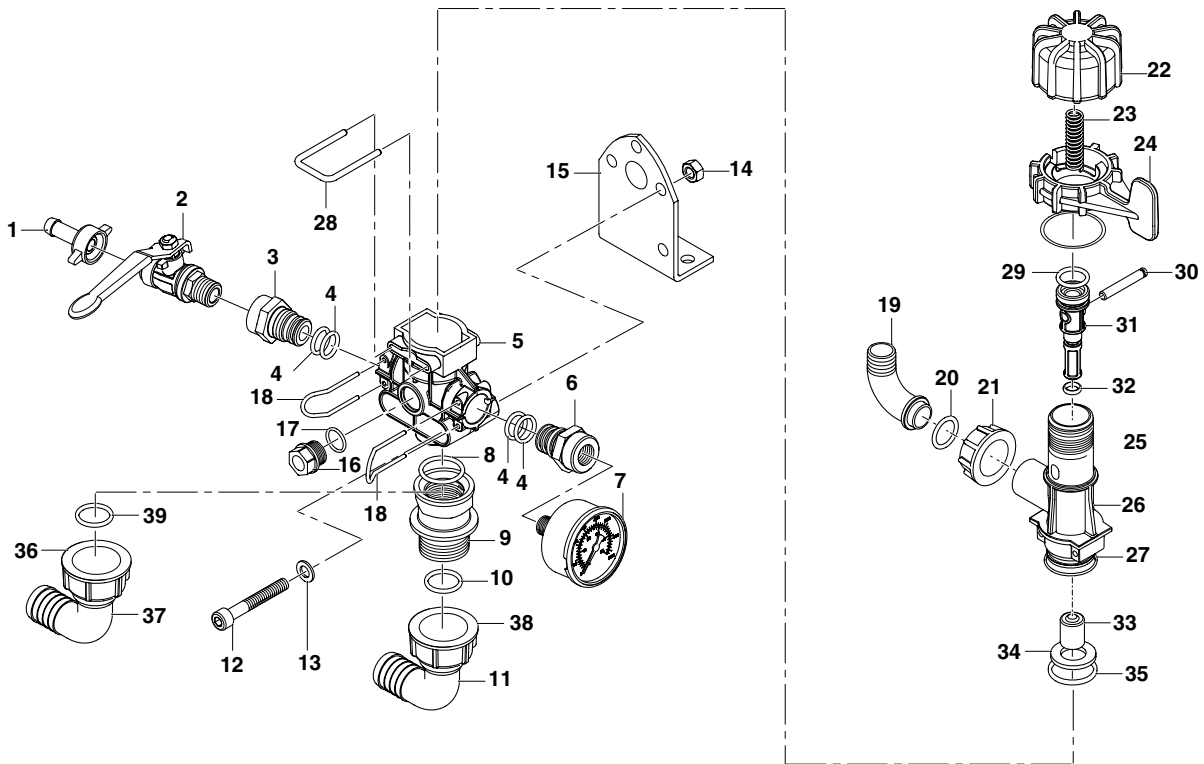

Ref. No.	Part Number	Description	Qty.
1	9910-110131	Hose Barb	1
2	9910-130492	Ball Valve	1
3	9910-3120421	Threaded Adapter	1
4	See O-ring Kits	O-ring	4
5	9910-3120390	Body	1
6	9910-3120420	Threaded Adapter	1
7	9910-1382410	Pressure Gauge	1
8	See O-ring Kits	O-ring	1
9	9910-3120660	Reducer Bushing	1
10	See O-ring Kits	O-ring	1
11	9910-3120460	Elbow	1
12	9910-680360	Bolt	2
13	9910-380241	Washer	2
14	9910-390270	Nut	2
15	9910-320406	Mounting Bracket	1
16	9910-3120690	Plug	1
17	See O-ring Kits	O-ring	1
18	9910-392580	Retaining Clip	2
19	9910-550460	Elbow	1
20	See O-ring Kits	O-ring	1

Ref. No.	Part Number	Description	Qty.
21	9910-550540	Ring Nut	1
22	9910-1880220	Adjustment Knob	1
23	9910-3120370	Spring	1
24	9910-1880210	Relief Lever	1
25	See O-ring Kits	O-ring	1
26	9910-3120280	Body	1
27	See O-ring Kits	O-ring	1
28	9910-3120320	Retaining Clip	1
29	See O-ring Kits	O-ring	1
30	9910-1880240	Pin	1
31	9910-3120290	Piston	1
32	See O-ring Kits	O-ring	1
33	9910-3120300	Piston	1
34	9910-3120310	Valve Seat	1
35	See O-ring Kits	O-ring	1
36	9910-3120430	Ring Nut	1
37	9910-3120450	Elbow	1
38	9910-3120440	Ring Nut	1
39	See O-ring Kits	O-ring	1

Model 9910-GS35

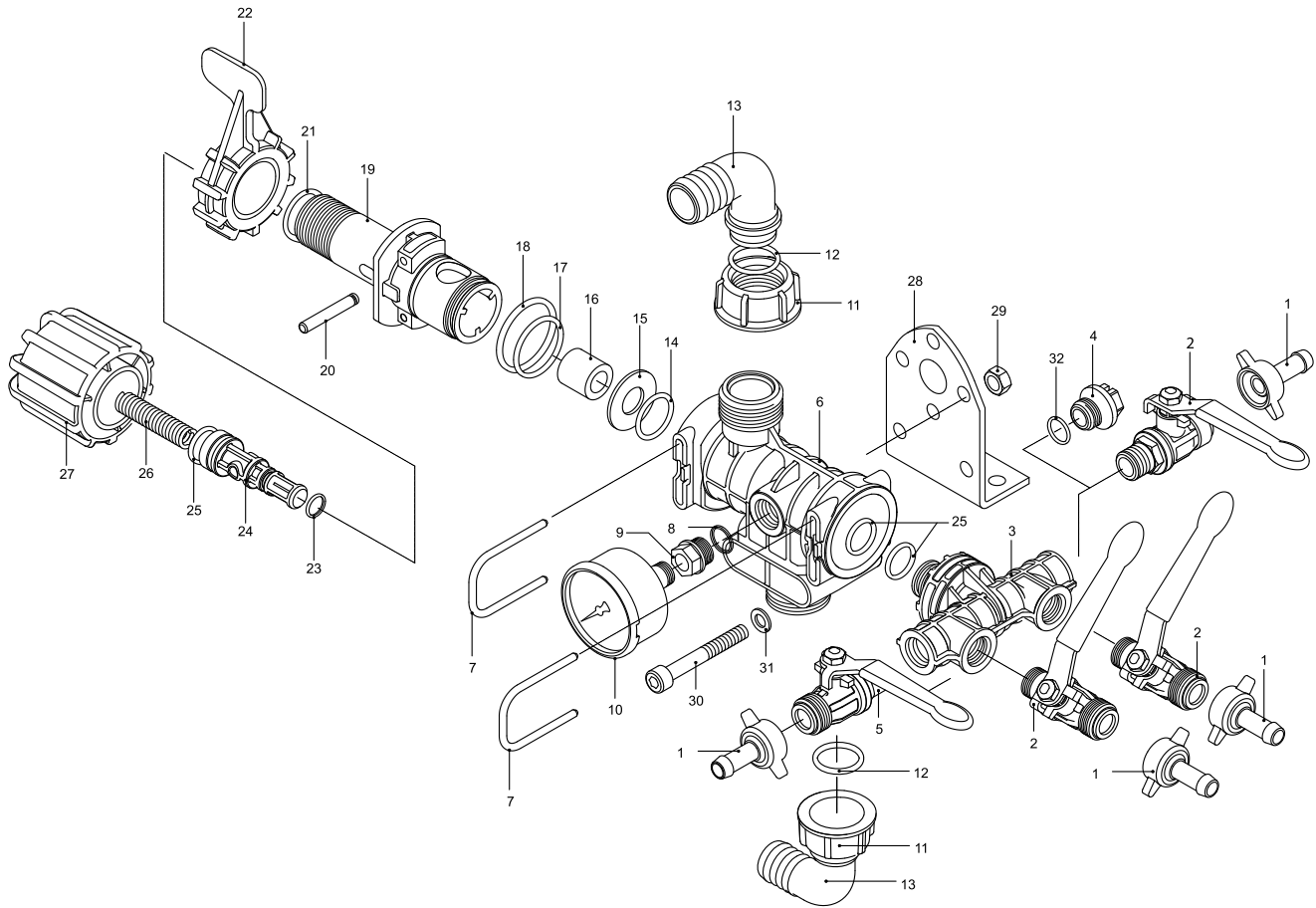

Ref. No.	Part Number	Description	Qty.	Ref. No.	Part Number	Description	Qty.
1	9910-110131	Hose Barb	4	17	See O-Ring Kits	O-Ring	1
2	9910-1880492	Left Ball Valve	3	18	See O-Ring Kits	O-Ring	1
3	9910-3240450	Body	1	19	9910-3240360	Spring	1
4	9910-3120690	Drain Plug	1	20	9910-1880240	Pin	1
5	9910-1880491	Right Ball Valve	1	21	See O-Ring Kits	O-Ring	1
6	9910-3240350	Body	1	22	9910-1880210	Lever	1
7	9910-3460210	Retaining Cup	3	23	See O-Ring Kits	O-Ring	1
8	See O-Ring Kits	O-Ring	1	24	9910-3240380	Piston	1
9	9910-1880250	Threaded Adapter	1	25	9910-480440	O-Ring	3
10	9910-1880340	Pressure Gauge	1	26	9910-3240410	Spring	1
11	9910-3120440	Nut	1	27	9910-3240440	Adjustment Knob	1
12	See O-Ring Kits	O-Ring	1	28	9910-320406	Base Plate	1
13	9910-3120460	Elbow	1	29	9910-3120690	Nut	1
14	See O-Ring Kits	O-Ring	1	30	9910-280080	Bolt	1
15	9910-3240420	Seat	1	31	9910-380241	Washer	1
16	9910-3240390	Valve	1	32	9910-2840890	O-Ring	1

Models 9910-DP423 and 9910-DP423GRGI

Fig. 1

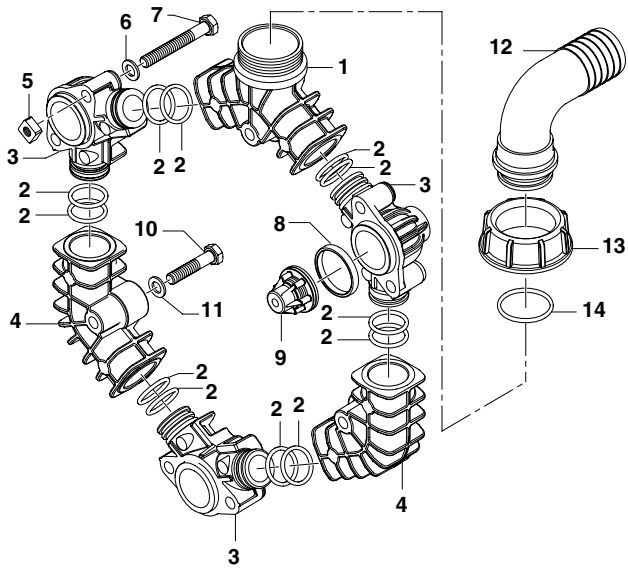

Fig. 2

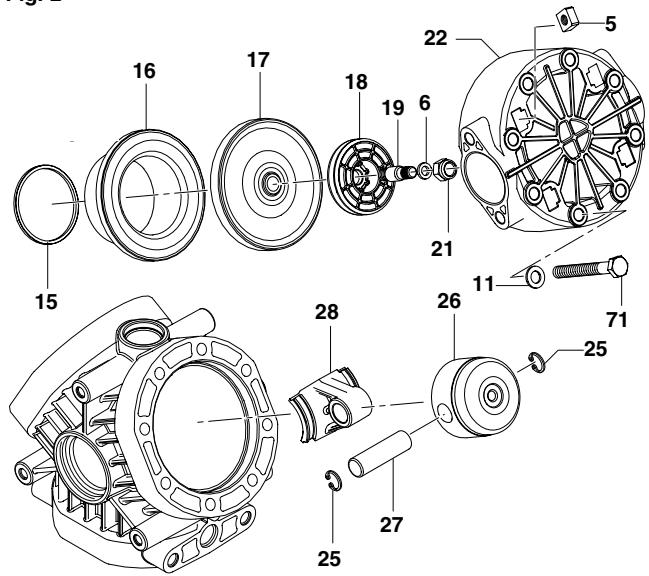

Fig. 3

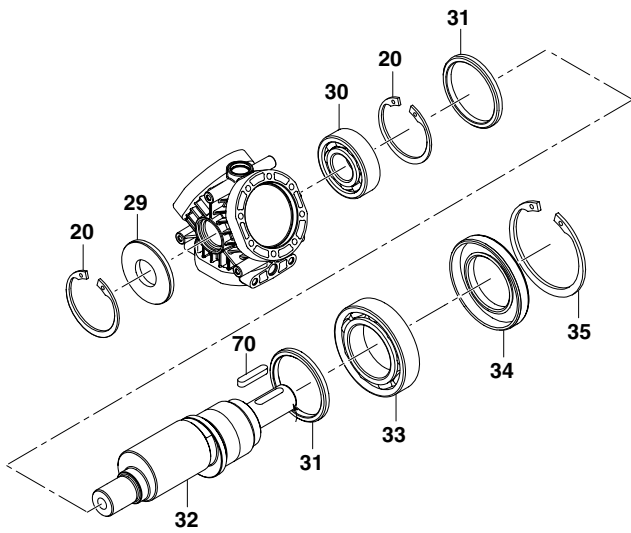

Fig. 4

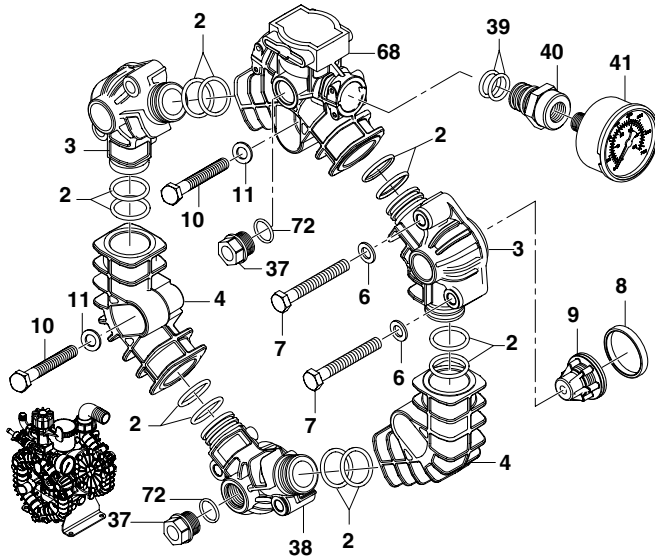

Fig. 5

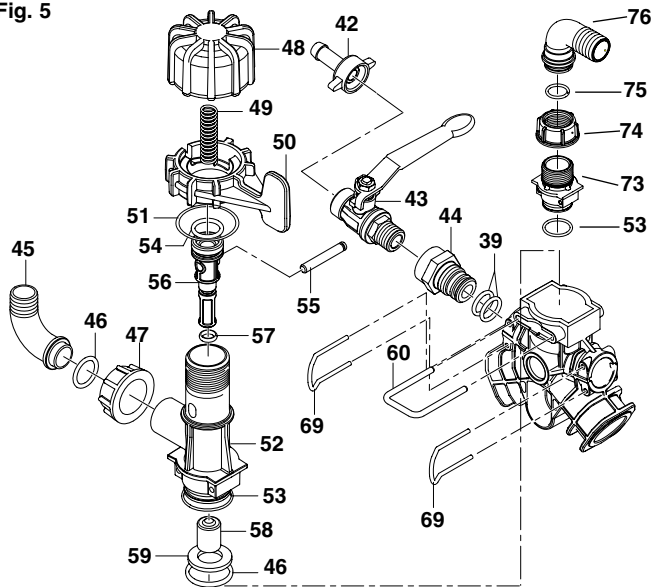
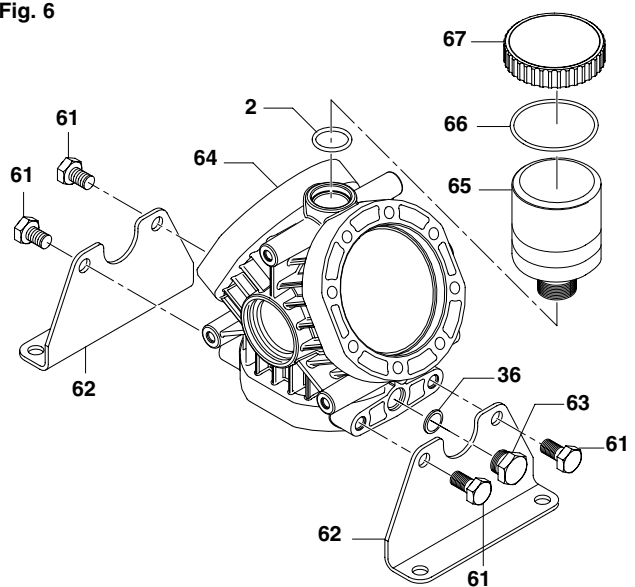

Fig. 6



Models 9910-DP423 and 9910-DP423GRGI

Ref. No.	Part Number	Description	Qty.
1	9910-3120410	Suction Manifold	1
2	See O-ring Kits	O-ring	25
3	9910-3120050	Manifold Section	5
4	9910-3120060	Manifold Section	4
5	9910-3120510	Nut	12
6	9910-380245	Washer	39
7	9910-3120250	Bolt	12
8	See Valve Kits	Gasket	6
9	See Valve Kits	Valve	6
10	9910-621782	Bolt	6
11	9910-390315	Washer	6
12	9910-3040160	Elbow	1
13	9910-750670	Ring Nut	1
14	See O-ring Kits	O-ring	1
15	9910-3120130	Piston Ring	3
16	9910-3120090	Sleeve	3
17	See Diaphragm Kits	Diaphragm	3
18	9910-3120120	Plate	3
19	9910-3120100	Diaphragm Stud	3
20	9910-1460490	Circlip	2
21	9910-3120110	Nut	3
22	9910-3120020	Head	3
25	9910-1880450	Circlip	6
26	9910-3120070	Piston	3
27	9910-380300	Pin	3
28	9910-3120180	Connecting Rod	3
29	9910-3120640	Shaft Seal	1
30	9910-380230	Bearing	1
31	9910-1300120	Retainer Ring	2
32	9910-3120170	Shaft	1
33	9910-961780	Bearing	1
34	9910-3120160	Shaft Seal	1
35	9910-961790	Circlip	1
36	See O-ring Kits	O-ring	3
37	9910-3120690	Drain Plug	2
38	9910-3120051	Manifold Section	1
39	See O-ring Kits	O-ring	4
40	9910-3120420	Threaded Adapter	1
41	9910-1880340	Pressure Gauge	1
42	9910-110131	Hose Barb	1
43	9910-130491	Left Ball Valve	1
44	9910-3120421	Threaded Adapter	1

Ref. No.	Part Number	Description	Qty.
45	9910-550460	Elbow	1
46	See O-ring Kits	O-ring	1
47	9910-550450	Ring Nut	1
48	9910-1880220	Adjustment Knob	1
49	9910-3120370	Spring	1
50	9910-1880210	Relief Lever	1
51	See O-ring Kits	O-ring	1
52	9910-3120280	Body	1
53	See O-ring Kits	O-ring	1
54	See O-ring Kits	O-ring	1
55	9910-1880240	Pin	1
56	9910-3120290	Piston	1
57	See O-ring Kits	O-ring	1
58	9910-3120300	Piston	1
59	9910-3120310	Seat	1
60	9910-3120320	Retaining Clip	1
61	9910-620342	Bolt	4
62	9910-3120140	Base	2
63	9910-880530	Plug	1
64	9910-3120010	Pump Body	1
65	9910-3120240	Oil Tank	1
66	See O-ring Kits	O-ring	1
67	9910-1040320	Cap	1
68	9910-3120330	Discharge Manifold (GRGI model)	1
68	9910-3120380	Discharge Manifold (non-GRGI model)	1
69	9910-392580	Retaining Clip	2
70	9910-2280950	Key	1
71	9910-3120270	Bolt	24
72	See O-ring Kits	O-ring	2
73	9910-3120610	Threaded Adapter	1
74	9910-3120440	Ring Nut	1
75	See O-ring Kits	O-ring	1
76	9910-3120460	Elbow	1

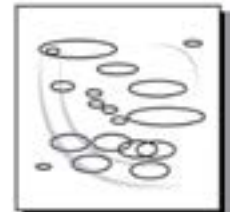

9910-KIT42599 Diaphragm Kit Buna	
9910-KIT42600 Diaphragm Kit Desmopan	
9910-KIT42601 Diaphragm Kit Viton	
Ref. No.	Qty.
98	3

9910-KIT42604 Valve Kit Buna	
9910-KIT42599 Valve Kit Viton	
Ref. No.	Qty.
77	6
78	6

9910-KIT42602 O-Ring Kit Buna	
9910-KIT42603 O-Ring Kit Viton	
Ref. No.	Qty.
1	24
2	2
11	2
14	1
20	1
22	1
25	3
28	1
30	1
33	1
35	1
49	1
52	1

9910-DP573 AND 9910-DP573GRGI AND 9910-DP763 AND 9910-DP763GRGI

Fig. 1

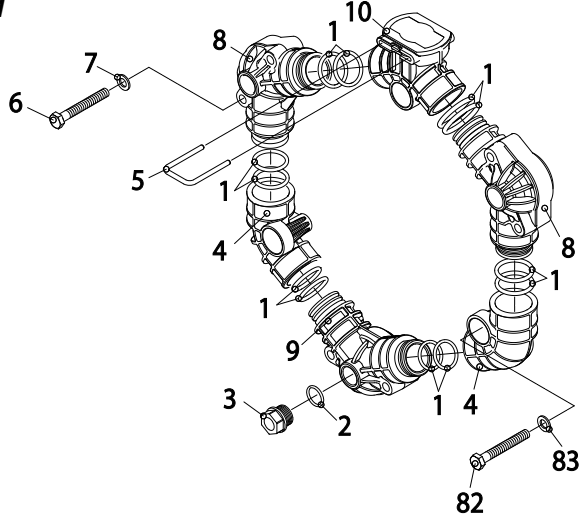

Fig. 2

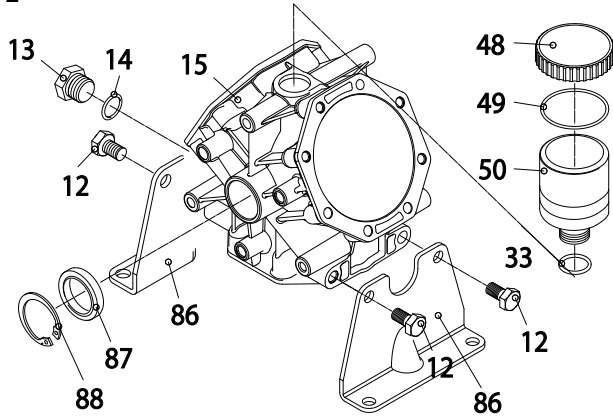

Fig. 3

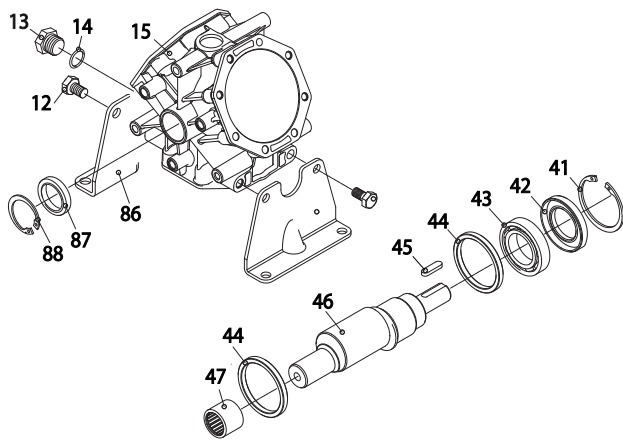

Fig. 4

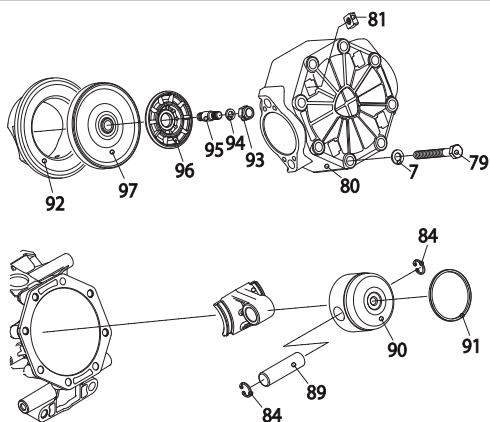

Fig. 5

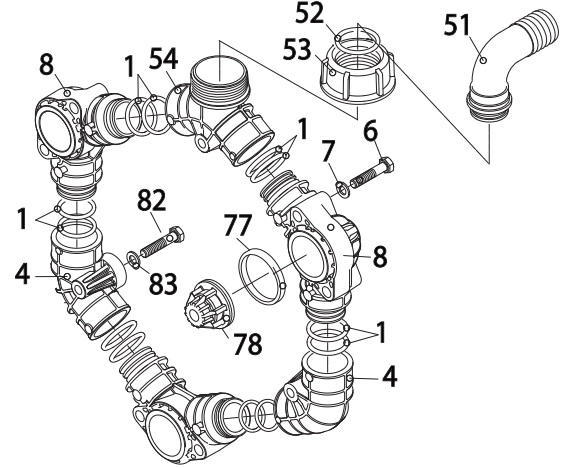

Fig. 6

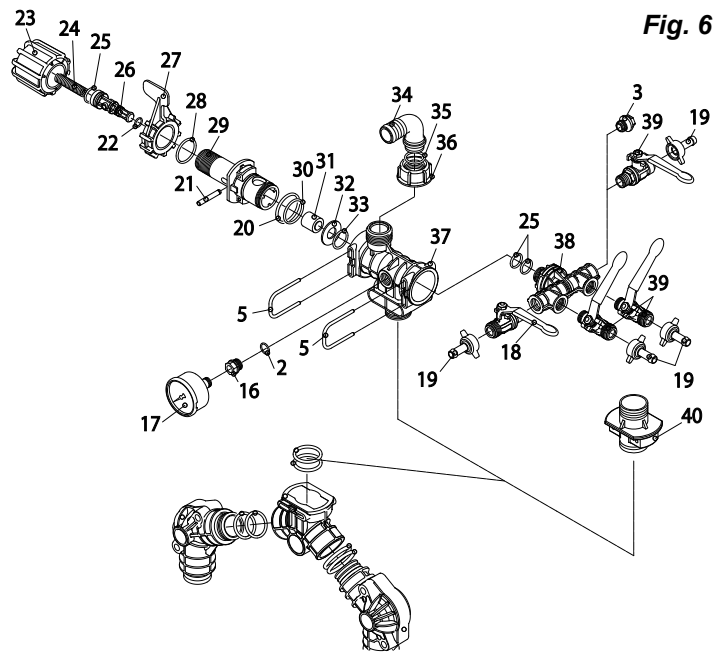
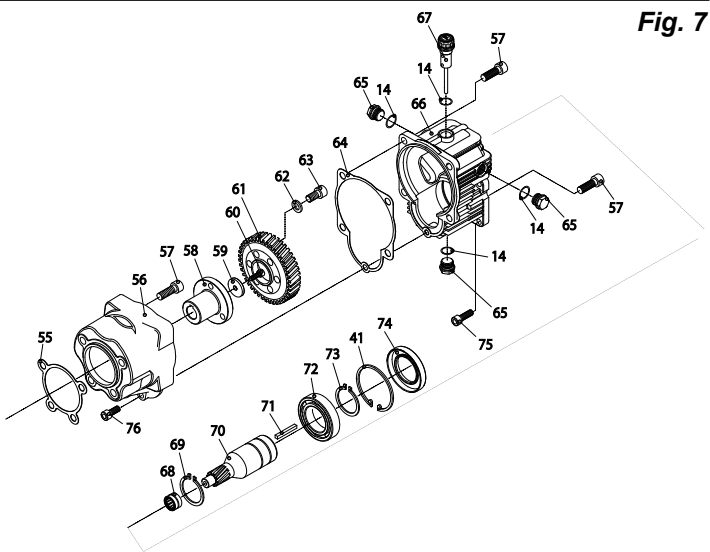

Fig. 7



9910-DP573 AND 9910-DP573GRGI AND 9910-DP763 AND 9910-DP763GRGI

Ref. No.	Part Number	Description	Qty.
1	See O-Ring Kits	O-Ring	24
2	See O-Ring Kits	O-Ring	2
3	9910-3120690	Drain Plug	1
4	9910-3240040	Manifold Section	4
5	9910-3460210	Retaining Clip	3
6	9910-380221	Bolt	12
7	9910-3120760	Washer	36
8	9910-3240030	Manifold Section	5
9	9910-3240031	Manifold Section	1
10	9910-3240080	Discharge Manifold	1
11	See O-Ring Kits	O-Ring	2
12	9910-320342	Bolt	4
13	9910-880530	Plug	1
14	See O-Ring Kits	O-Ring	1
15	9910-3240010	Pump Body	1
16	9910-1880250	Threaded Adapter	1
17	9910-1880340	Pressure Gauge	1
18	9910-1880491	Right Ball Valve	1
19	9910-110131	Hose Barb	4
20	See O-Ring Kits	O-Ring	1
21	9910-1880240	Pin	1
22	See O-Ring Kits	O-Ring	1
23	9910-3140440	Adjustment Knob	1
24	9910-3240410	Spring	1
25	9910-480440	O-Ring	3
26	9910-3240380	Piston	1
27	9910-1880210	Lever	1
28	See O-Ring Kits	O-Ring	1
29	9910-3210360	Spring	1
30	See O-Ring Kits	O-Ring	1
31	9910-3240390	Valve	1
32	9910-3240420	Seat	1
33	See O-Ring Kits	O-Ring	1
34	9910-3120460	Elbow	1
35	See O-Ring Kits	O-Ring	1
36	9910-3120440	Nut	1
37	9910-3240350	Body	1
38	9910-3240450	Body	1
39	9910-1880492	Left Ball Valve	3
40	9910-3240460	Threaded Adapter	1
41	9910-961790	Cir Clip	1
42	9910-3120160	Seal Ring	1
43	9910-961780	Bearing	1
44	9910-3240320	Retaining Ring	2
45	9910-2280950	Key	1
46	9910-3240180	Shaft (9910-DP573)	1
46A	9910-3240190	Shaft (9910-DP763)	1
47	9910-3460110	Bearing	1
48	9910-1040320	Cap	1
49	See O-Ring Kits	O-Ring	1
50	9910-3120240	Oil Tank	1
51	9910-50267	Elbow	1
52	See O-Ring Kits	O-Ring	1
53	9910-750670	Nut	1
54	9910-3240050	Suction Manifold	1
55	9910-3120360	Gasket	1
56	9910-3120340	Flange	1
57	9910-540300	Bolt	8
58	9910-3460290	Gear Hub	1
59	9910-780230	Washer	1
60	9910-880280	Bolt	1
61	9910-651620	Gear	1
62	9910-200231	Washer	3
63	9910-620470	Bolt	3
64	9910-620950	Gasket	1

Ref. No.	Part Number	Description	Qty.
65	9910-1980740	Plug	3
66	9910-620960	Gearbox Housing	1
67	9910-1140370	Plug	1
68	9910-620990	Bearing	1
69	9910-320240	Cir Clip	1
70	9910-621660	Pinion Gear - 3/4" Shaft Only	1
71	9910-881090	Key	1
72	9910-961780	Ball Bearing	1
73	9910-320240	Cir Clip	1
74	9910-961800	Seal Ring	1
75	9910-651000	Bolt	4
76	9100-180030	Bolt	1
77	See Valve Kits	Gasket	6
78	See Valve Kits	Valve	6
79	9910-621771	Bolt	24
80	9910-3240020	Head	3
81	9910-3120510	Nut	12
82	9910-3240280	Bolt	6
83	9910-390315	Washer	6
84	9910-1040270	Cir Clip	6
85	9910-3240120	Connecting Rod	3
86	9910-3240090	Base Plate	2
87	9910-1300230	Seal Ring	1
88	9910-480900	Cir Clip	1
89	9910-1040090	Piston Pin	3
90	9910-1040120	Piston	3
91	9910-650190	Piston Ring	3
92	9910-3240140	Sleeve	3
93	9910-2240110	Nut	3
94	9910-320622	Washer	3
95	9910-3240100	Diaphragm Stud	3
96	9910-3240110	Diaphragm Retaining Plate	3
97	See Diaphragm Kit	Diaphragm	3

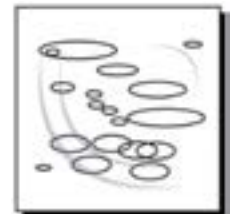

9910-KIT42813 Diaphragm Kit Buna	
9910-KIT42814 Diaphragm Kit Desmopan	
9910-KIT42815 Diaphragm Kit Viton	
Ref. No.	Qty.
98	3

9910-KIT42811 Valve Kit Buna	
9910-KIT42812 Valve Kit Viton	
Ref. No.	Qty.
77	6
78	6

9910-KIT42994 O-Ring Kit Buna	
9910-KIT42995 O-Ring Kit Viton	
Ref. No.	Qty.
1	24
2	2
11	2
14	1
20	1
22	1
25	3
28	1
30	1
33	1
35	1
49	1
52	1

Operating Instructions

SYMPTOM	PROBABLE CAUSE(S)	CORRECTIVE ACTION
The pump does not draw water.	One or more valves are seating improperly.	Remove valve and check for debris. Remove any debris found. Examine the valve seatings and clean them.
	Suction line is plugged or collapsed. Clogged strainer.	Examine and clean the suction line. Clean the strainer.
The liquid flow is irregular.	The charge in the pulsation dampener is incorrect.	Check the pressure in the pulsation dampener. (It should be 20% of your spray pressure.)
	One or more valves are seating improperly.	Remove valve and check for debris. Remove any debris found. Examine the valve seatings and clean them.
Output drops and the pump is noisy.	The oil level is too low.	Add oil to the correct level (halfway up the sight tube).
Oil comes out of the discharge port or oil is a milky color.	One or more diaphragms have split.	Remove the manifold and heads. Drain the oil and clean the crankcase of water. Replace the diaphragms, heads, and manifold. Refill with Hyrpo Oil (part number 2160-0038).

THIS PAGE INTENTIONALLY LEFT BLANK

Limited Warranty on Hypro/Shurflo Agricultural Pumps & Accessories

Hypro/Shurflo (hereafter, "Hypro") agricultural products are warranted to be free of defects in material and workmanship under normal use for the time periods listed below, with proof of purchase.

- Pumps: one (1) year from the date of manufacture, or one (1) year of use. This limited warranty will not exceed two (2) years, in any event.
- Accessories: ninety (90) days of use.

This limited warranty will not apply to products that were improperly installed, misapplied, damaged, altered, or incompatible with fluids or components not manufactured by Hypro. All warranty considerations are governed by Hypro's written return policy.

Hypro's obligation under this limited warranty policy is limited to the repair or replacement of the product. All returns will be tested per Hypro's factory criteria. Products found not defective (under the terms of this limited warranty) are subject to charges paid by the returnee for the testing and packaging of "tested good" non-warranty returns.

No credit or labor allowances will be given for products returned as defective. Warranty replacement will be shipped on a freight allowed basis. Hypro reserves the right to choose the method of transportation.

This limited warranty is in lieu of all other warranties, expressed or implied, and no other person is authorized to give any other warranty or assume obligation or liability on Hypro's behalf. Hypro shall not be liable for any labor, damage or other expense, nor shall Hypro be liable for any indirect, incidental or consequential damages of any kind incurred by the reason of the use or sale of any defective product. This limited warranty covers agricultural products distributed within the United States of America. Other world market areas should consult with the actual distributor for any deviation from this document.

Return Procedures

All products must be flushed of any chemical (ref. OSHA section 1910.1200 (d) (e) (f) (g) (h)) and hazardous chemicals must be labeled/tagged before being shipped* to Hypro for service or warranty consideration. Hypro reserves the right to request a Material Safety Data Sheet from the returnee for any pump/product it deems necessary. Hypro reserves the right to "disposition as scrap" products returned which contain unknown fluids. Hypro reserves the right to charge the returnee for any and all costs incurred for chemical testing, and proper disposal of components containing unknown fluids. Hypro requests this in order to protect the environment and personnel from the hazards of handling unknown fluids.

Be prepared to give Hypro full details of the problem, including the model number, date of purchase, and from whom you purchased your product. Hypro may request additional information, and may require a sketch to illustrate the problem.

Contact Hypro Service Department at 800-468-3428 to receive a Return Merchandise Authorization number (RMA#).

Returns are to be shipped with the RMA number clearly marked on the outside of the package. Hypro shall not be liable for freight damage incurred during shipping. Please package all returns carefully. All products returned for warranty work should be sent shipping charges prepaid to:

HYPRO / PENTAIR
Attention: Service Department
375 Fifth Avenue NW
New Brighton, MN 55112 USA

For technical or application assistance, call the **Hypro Technical/Application number: 800-445-8360**, or send an email to: **technical@hypropumps.com**. To obtain service or warranty assistance, call the **Hypro Service and Warranty number: 800-468-3428**; or send a fax to the **Hypro Service and Warranty FAX: 651-766-6618**.

*Carriers, including U.S.P.S., airlines, UPS, ground freight, etc., require specific identification of any hazardous material being shipped. Failure to do so may result in a substantial fine and/or prison term. Check with your shipping company for specific instructions.

