

## Installation, Operation, Repair and Parts Manual

### Description

**⚠ California Proposition 65 Warning --** This product and related accessories contain chemicals known to the State of California to cause cancer, birth defects or other reproductive harm.

Hypro Centrifugal Pumps handle big, high-capacity farm spraying jobs with ease. Use them for spraying liquid fertilizers and other chemicals, including wettable powder

slurries for weed control. Make short work of other farm jobs - filling nurse tanks, watering seed beds, and transferring liquids.

Hypro gear-driven centrifugal pumps are sturdy, smooth running units and are available in both standard and self-priming models.

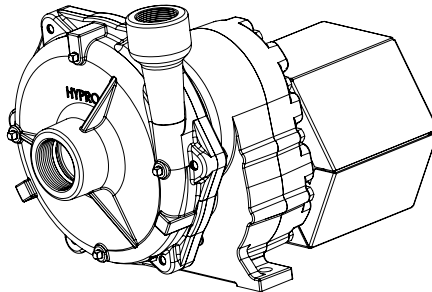

### **SERIES 9047C**

#### **Cast Iron, Gear-Driven Centrifugal Pump**

Max. Flow Rate: ..... 213 gpm  
 Max. Pressure: ..... 180 psi  
 Max. Speed: ..... 540 rpm  
 Ports: ..... 2" NPT inlet  
 1-1/2" NPT outlet

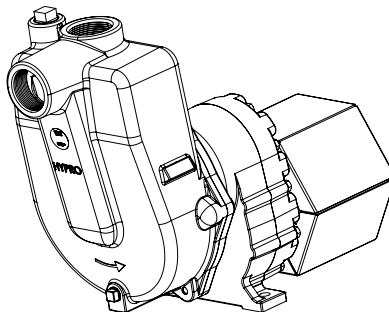

### **SERIES 9047C-SP and 9047C-BSP**

#### **Cast Iron, Gear-Driven, Centrifugal Pump**

Max. Flow Rate: ..... 195 gpm  
 Max. Pressure: ..... 170 psi  
 Max. Speed: ..... 540 rpm  
 Ports: ..... 2" NPT inlet (SP)  
 2" NPT outlet (SP)  
 2" BSP inlet (BSP)  
 2" BSP outlet (BSP)

## General Safety Information

### NOTE

Notes are used to notify of installation, operation, or maintenance information that is important but not safety related.

### CAUTION

Caution is used to indicate the presence of a hazard, which will or may cause minor injury or property damage if the notice is ignored.

### DANGER

Do not pump flammable or explosive fluids such as gasoline, fuel oil, kerosene, etc. Do not use in explosive atmospheres. Components not rated for use with Anhydrous Ammonia. The pump should only be used with liquids compatible with the pump materials. Failure to follow this notice may result in severe personal injury and/or property damage and will void the product warranty.

Be sure all exposed moving parts, such as PTO shafts and adapters, are properly shielded or guarded and that all coupling devices are securely attached before applying power.

### WARNING

The sound pressure level of the pump may exceed 80dBA. Observe all safety precautions when operating the pump within close proximity for extended periods by wearing hearing protectors. Extended exposure to elevated sound levels will result in permanent loss of hearing acuteness, tinnitus, tiredness, stress, and other effects such as loss of balance and awareness.

### CAUTION

- Do not pump at pressures higher than the maximum recommended pressure.
- Operate the pump between a temperature range of 45° to 140° F [7° to 60° C]. Protect pump from freezing conditions by draining liquid and pumping rust-inhibiting antifreeze solution through the system, coating the pump interior.
- Make certain that the power source conforms to the requirements of your equipment.

### WARNING

Warning denotes that a potential hazard exists and indicates procedures that must be followed exactly to either eliminate or reduce the hazard, and to avoid serious personal injury, or prevent future safety problems with the product.

### DANGER

Danger is used to indicate the presence of a hazard that will result in severe personal injury, death, or property damage if the notice is ignored.

- Provide adequate protection in guarding around the moving parts such as shafts and pulleys. Pumps mounted directly onto PTO shaft or other power shaft must be prevented from rotating with the power shaft. Pump must float freely on the power shaft and must not be tied rigidly to equipment on which it is mounted.

Before servicing, disconnect all power. Make sure all pressure in the system is relieved. Drain all liquids from the system and flush.

- Drain all liquids from the system before servicing.
- Secure the discharge line before starting the pump. An unsecured discharge line may whip, resulting in personal injury and/or property damage.
- Check all hoses for weak or worn condition before each use. Make certain that all connections are tight and secure.
- Periodically inspect the pump and the system components. Perform routine maintenance as required (See Maintenance).
- Use only pipe, hose, and hose fittings rated for maximum rated pressure of the pump or the pressure at which the pressure relief valve is set at. Do not use used pipe.
- Do not use these pumps for pumping water or other liquids for human or animal consumption.

## Hazardous Substance Alert

1. Always drain and flush pump before servicing or disassembling for any reason (see instructions).
2. Always drain and flush pump prior to returning unit for repair.
3. Never store pumps containing hazardous chemicals.
4. Before returning pump for service/repair, drain out all liquids and flush unit with neutralizing liquid. Then, drain the pump. Attach tag or include written notice certifying that this has been done.

### NOTE

It is illegal to ship or transport any hazardous chemicals without United States Environmental Protection Agency Licensing.

# Plumbing Installation

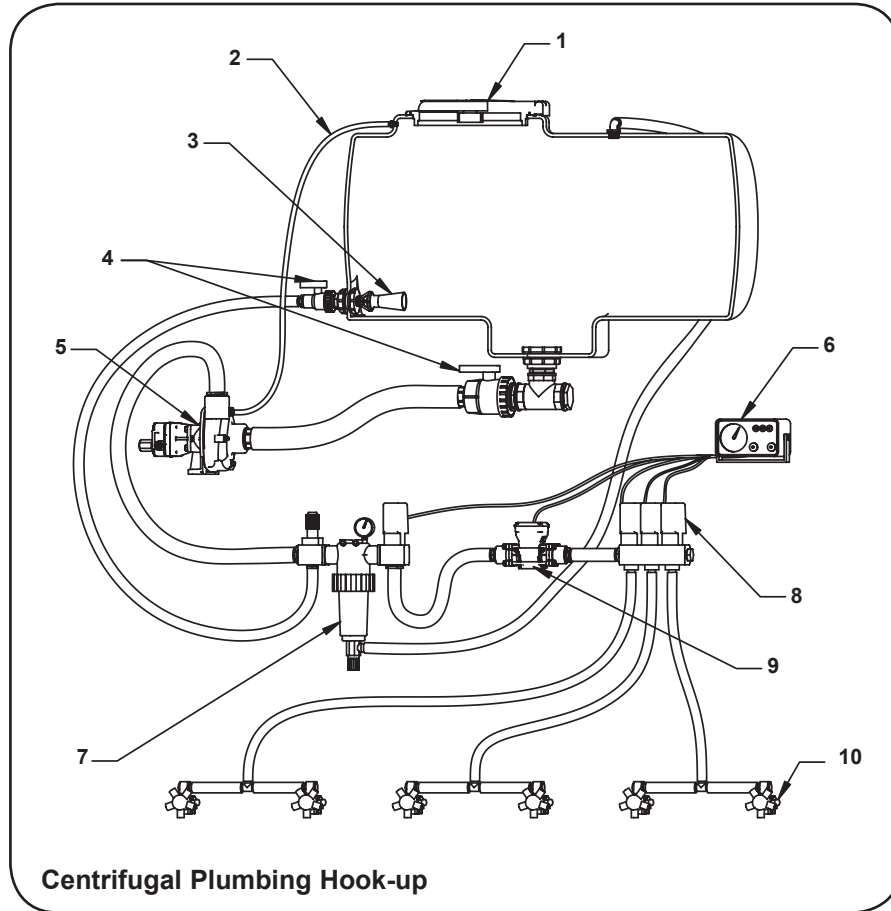

REF. NO.	DESCRIPTION
1	Tank Lid
2	Vent Line #3430-0456
3	Jet Agitator
4	Shut-off Ball Valves
5	Centrifugal Pump
6	Spray Control Console
7	Centrifugal Pump Control
8	Manifold Boom Valve
9	Electromagnetic Flowmeter
10	Compact Jet Turret Nozzle Body

## Installation Instructions

### **Pump Installation:**

The following are recommendations to achieve the optimal performance out of your centrifugal pump and your spraying system.

### **Pump Inlet Line**

To achieve full capacity from the pump, the inlet line should be at least the same size as the inlet port on the pump. Reducing this line size will restrict the capabilities of the pump. The line must also be free of air leaks. Check all fittings and connections in the suction line for tightness. The introduction of air may affect the priming and pumping capabilities of the pump. Use good quality suction hose that will not be collapsed by suction.

For non-self-priming models, the centrifugal pump should be mounted below the liquid level and as near to the liquid source as possible to allow for the shortest suction line practical. To achieve optimal performance, the suction line should slope down into the pump. Avoid rises and humps that could trap air in the line to the pump. The suction line and pump should be filled with liquid prior to starting the pump, and all discharge lines should be open.

### **Pump Outlet Line**

The recommended orientation for the outlet port is pointing straight up. This allows liquid to stay in the pump while it is priming. The outlet line should be the same size as the pressure port on the pump to give the optimal flow. The line should have as few restrictions and elbows as possible to optimize the pump performance and reduce pressure drop from the pump to the spray tips.

### **Priming The Pump:**

#### **IMPORTANT: The pump must not be run dry.**

Before starting the pump, the inlet line and pump must be filled with liquid and all discharge lines must be open. On self-priming models, only the pump chamber needs to be filled with liquid. The pump must not be run unless it is completely filled with liquid because there is a danger of damaging the mechanical seal, which depends on the liquid for its lubrication.

Non-self-priming models should be mounted below the level of the liquid. The suction line should slope down to the pump and be free of dips and bends. If this cannot be done, a foot valve should be installed in the end of the inlet line so that the line can be completely filled with liquid before starting the pump.

### **Centrifugal Pump Control**

Hypro now offers many different components for spraying systems. The Hypro centrifugal pump control incorporates the electric flow control valve, a self-cleaning line strainer, a visual pressure gauge and a manual agitation control valve.

### **Flow Control Valve**

A high-flow electric proportional valve allows for maximum flow control to the boom valves. It provides smooth, rapid control that can be controlled from either an electronic rate controller or switch box.

### **Strainers**

The recommended placement of the strainer for a centrifugal pump is in the pump outlet line. This will eliminate any possible restriction that the strainer could create if it were installed in the inlet line. Ensure that the proper strainer size and screen mesh are used to limit the pressure drop and achieve the best filtration. Line strainers can also be installed in the tank fill line to filter liquid as it is loaded into the tank as well as in the boom lines to further filter the solution prior to the spray tips. Tank baskets can also be used to filter material added through the tank lid.

### **Agitation**

The centrifugal pump control contains a manual agitation control valve that can be adjusted to provide the right amount of flow to the jet agitators in the tank to ensure proper mixing within the tank.

### **Flowmeter**

To eliminate the mechanical problems of a turbine flowmeter, we recommend that an electromagnetic flowmeter be used. These flowmeters have no moving parts to wear out and will provide a more consistent and accurate flow reading. They can be input into just about any electronic rate controller or switch box.

### **Boom Section Valves**

For rapid response and reliability, we recommend electric plunger valves be used for boom control. The valves should be sized accordingly to minimize the pressure drop and maximize the flow rate. The boom tubing or hose should be sized accordingly to ensure that a pressure drop in the lines does not occur, causing inconsistent pressures at the nozzles.

### **Nozzle Bodies**

Nozzle bodies with shut-off check valves are recommended to eliminate dripping from the spray tips when the boom valves are shut down.

**For further information  
regarding Hypro products,  
contact your local dealer  
or Hypro directly at [www.  
hypropumps.com](http://www.hypropumps.com) or by call-  
ing 1-800-424-9776.**

# Operation and Maintenance

## **⚠ CAUTION**

**Engage the PTO clutch slowly and smoothly. Avoid sudden starts and fast clutching that may damage the drive section of the pump.**

### **Controlling the Flow**

Two Flow Control Valves are used - one in the agitation line and one in the line leading to the boom or spray gun. This permits controlling agitation flow independently of nozzle flow.

### **To Adjust For Spraying**

To adjust the sprayer (regardless of power source - PTO, belt or pulley), follow these steps:

1. Prime the pump with all valves open.
2. Close Control Valve and Agitation Line Valve; then open the Boom Shut-Off Valve.
3. With the pump running, open the Control Valve until the Pressure Gauge indicates desired spraying pressure.
4. Open the the Agitation Line Valve until sufficient agitation is observed. Then, if spraying pressure drops, readjust the Control Valve to restore desired pressure.
5. Make sure flow is uniform from all nozzles.

After spraying adjustments are made, it is only necessary to close the Boom Shut-Off Valve to discontinue spraying. On belt-drive models, check belt tension daily or before each use.

### **Flush Pump After Use**

One of the most common causes for faulty pump performance is “gumming” or corrosion inside the pump. Flush the pump and entire system with a solution that will chemically neutralize the liquid pumped. Mix according to manufacturer’s directions. This will dissolve most residue remaining in the pump, leaving the inside of the pump clean for the next use.

### **To Prevent Corrosion**

After cleaning the pump as directed above, flush it with a permanent-type automobile antifreeze (Prestone, Zerex, etc.) containing a rust inhibitor. Use a 50/50 solution of antifreeze and water. Plug the ports to keep out air during storage. For short periods of idleness, non-corrosive liquids may be left in the pump, but air must be kept out. Plug the ports or seal port connections.

## **Gear Box Information and Maintenance Lubrication**

The pump gear case is lubricated at the factory. Re-lubricate after 250 hours of operation or at the start of each season. Also lubricate whenever gear case is opened for repair. To lubricate, remove uppermost plug from gear box with 1/4” Allen wrench. Fill gear case with the specified amount of 90W AGMA 5EP gear lube (specified in table below). The amount of gear lube required is dependent on the orientation of the gear box. The standard gear box orientation (mounting feet down) requires 10 US fl. oz. of the recommended gear lube type; the inverted gearbox orientation (mounting feet up) requires 18 US fl. oz. of the recommended gear lube type. Do not overfill. Replace plug back in same location on gear box. Ensure the vent/ breather plug is installed in the upper port position of the gear box, and not the drain plug. Drain plugs come installed in both port positions from the factory to prevent leaks during shipping. The vent/breather plug must be installed in the upper port position before initial use.

Gear Lube Volume Requirements

Pump Model	Gearbox Orientation	Gear Lube Required
9047C	Standard	10 US FL OZ/ 295.74 mL
9047C-SP 9047C-BSP		
90030	Inverted	18 US FL OZ/ 532.32 mL

### **WARNING!**

- 1) Changing installed gear box orientation from STANDARD to INVERTED requires addition of gear lube from 10 to 18 oz.
- 2) Changing installed gear box orientation from INVERTED to STANDARD requires draining of gear lube from 18 to 10 oz.

## Repair Instructions

**CAUTION** Always flush the pump with water or neutralizing agent before servicing

### Pump Housing Dissassembly

1. Remove the six casting cap screws with a 5/8" box wrench.  
Tap pump casing on discharge port with rubber hammer, if needed.  
Check inside of pump casing, including suction port. If badly eroded (or damaged), pump casting should be replaced.
2. To remove impeller, clamp the gear box shaft in vise as shown.  
Take caution to protect shaft from being damaged by vise jaws.  
This will prevent rotation of shaft and allow the impeller to be unscrewed. To unscrew impeller, use a small diameter shaft or file inserted into vanes and turn counterclockwise



Ref. 2



Ref. 3

### Pump Seal Removal

3. Apply lubricant (WD-40 oil or detergent) to shaft and rubber boot area of rotary seal for easier removal. Push seal down to allow lubricant to penetrate around shaft.
4. To remove rotary part of seal, use two screwdrivers positioned on each side and pry up the rotary part of the seal.
5. Remove the four pump plate cap screws with 1/2" box wrench. Then remove rubber slinger and stationary seat of seal plus its o-ring seal from pump plate. It may be necessary to destroy the stationary seal seat with a punch or chisel for removal. Silicon carbide material is very brittle and will crack easily.

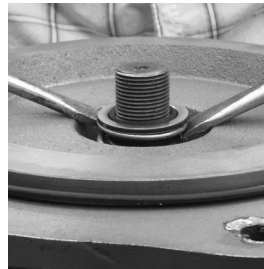

Ref. 4



Ref. 5

**CAUTION** The seal will be damaged from removal. A new seal **MUST** be used when pump is reassembled.

## Repair - continued

Be extremely careful with the new seal. Silicon carbide material is very hard, but also very brittle. If the seal is accidentally dropped and hits a hard surface, the seal's primary ring (rotary part) and mating ring (stationary seal seat) can be damaged. Also take precautions not to introduce dirt or grit to the seal surfaces.

1. Inspect seal seat cavity to be sure it is clean and without debris. Foreign material at the bottom of the seal seat bore can cause the mating ring to be slightly cocked.

**Important:**

**Make sure seal cavity is clean and lubricated with detergent; don't use oil for assembly lubrication.**

2. Lubricate (Stationary Part) of seal and seal seat cavity in mounting flange with detergent to aid in smooth installation.
3. Install (Stationary Part) of seal into seat bore.  
**Note:** The side of the mating ring with the notch is positioned towards the bottom of the seal bore.
4. Press (Stationary Part) of seal into seal cavity bore on pump mounting plate using a nylon or soft tool applying uniform hand force. Seal will pop into place and bottom out once o-ring has slipped inside the leading edge of the seat cavity. Be sure seal is completely seated and not cocked.
5. Install new rubber slinger onto gear box shaft over (Rotary Part) of seal.
6. Next reassemble pump mounting plate with four cap screws (torque to 15 ft-lbs) using 1/2 wrench onto gear box. Index plate position to align weep hole on plate to down position.
7. To install (Rotary Part) of seal, first lubricate shaft and inside rubber boot of seal with one to two drops of detergent in one cup of water only. (**Note:** Do not use 100% detergent or oil for lubricant on this part). Next install (Rotary Part) of seal onto shaft, making sure silicon carbide end is facing down. Lightly press (Rotary Part) of seal down shaft over threaded area until it bottoms out on (Stationary Part) of seal.

**Important:**

**Do not rotate or thread (Rotary Part) of seal down on shaft over threaded area. This may cause cuts or damage to inside of (Rotary Part) rubber boot.**

8. Install rubber gasket (P/N 1700-0121) onto shaft before re-installing impeller.
9. Install impeller into shaft by hand threading clockwise onto shaft. If you use a small diameter shaft or file to do final tightening, do so lightly, as too much force may damage impeller vanes.
10. Install o-ring on pump mounting plate. Replace o-ring if worn or damaged.
11. Reassemble pump casting with six cap screws (torque to 25 ft-lbs) using a 5/8" box wrench, and tighten bolts evenly to compress o-ring seal.

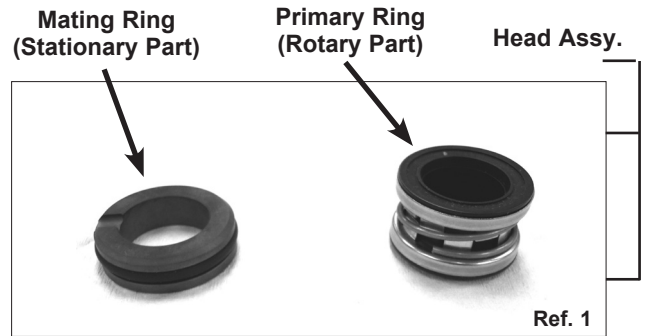

*Life Guard Mechanical Seal*



Ref. 2

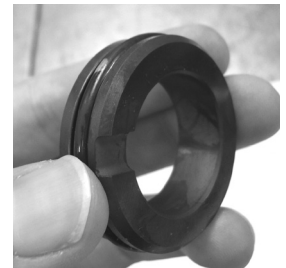

Ref. 3



Ref. 4

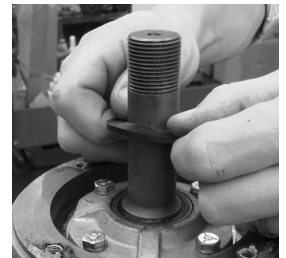

Ref. 5



Ref. 6



Ref. 7



Ref. 9



Ref. 10

# Troubleshooting

Symptom	Probable Cause(s)	Corrective Action(s)
Low Discharge	Pump not primed.  Air leaks in suction line. Blocked or clogged line strainer. Impeller plugged. Undersize suction line or collapsed hose.  Eye of impeller rubbing on volute.	- Remove topmost vent plug from face of pump and run pump to expel trapped air (See Installation Instructions). - Check and reseal inlet fittings. - Inspect strainer and clear any debris from screen. - Inspect and clear obstruction. - Suction line should be the same diameter as inlet port of pump or larger. - Remove volute (front cover) and inspect the impeller. If wear detected, sand the impeller eye O.D. with emery cloth.

## Performance Charts

### Performance-tested in Water

#### Model 9047C

RPM	U.S. Units																
	GPM at 20 PSI	GPM at 30 PSI	GPM at 40 PSI	GPM at 50 PSI	GPM at 60 PSI	GPM at 70 PSI	GPM at 80 PSI	GPM at 90 PSI	GPM at 100 PSI	GPM at 110 PSI	GPM at 120 PSI	GPM at 130 PSI	GPM at 140 PSI	GPM at 150 PSI	GPM at 160 PSI	GPM at 170 PSI	GPM at 180 PSI
450	189	189	188	188	186	184	176	168	140	119	69	-	-	-	-	-	-
500	199	199	199	198	197	196	195	194	193	186	172	145	106	-	-	-	-
540	213	211	211	210	209	209	208	207	206	205	201	195	192	174	148	116	66

#### Model 9047C

RPM	Metric Units																
	LPM at 1.4 BAR	LPM at 2.1 BAR	LPM at 2.8 BAR	LPM at 3.4 BAR	LPM at 4.1 BAR	LPM at 4.8 BAR	LPM at 5.5 BAR	LPM at 6.2 BAR	LPM at 6.9 BAR	LPM at 7.6 BAR	LPM at 8.3 BAR	LPM at 8.9 BAR	LPM at 9.7 BAR	LPM at 10.3 BAR	LPM at 11.0 BAR	LPM at 11.7 BAR	LPM at 12.4 BAR
450	715	715	712	710	705	695	665	635	530	450	260	-	-	-	-	-	-
500	755	755	755	750	745	742	740	735	730	705	650	550	400	-	-	-	-
540	805	800	800	795	790	790	789	785	778	775	760	740	725	660	560	440	250

#### Models 9047C-SP, 9047C-BSP

RPM	U.S. Units															
	GPM at 20 PSI	GPM at 30 PSI	GPM at 40 PSI	GPM at 50 PSI	GPM at 60 PSI	GPM at 70 PSI	GPM at 80 PSI	GPM at 90 PSI	GPM at 100 PSI	GPM at 110 PSI	GPM at 120 PSI	GPM at 130 PSI	GPM at 140 PSI	GPM at 150 PSI	GPM at 160 PSI	
450	174	173	169	166	157	140	119	92	61	26	-	-	-	-	-	
500	185	182	180	178	174	172	164	153	132	119	95	69	20	-	-	
540	195	194	194	193	190	186	184	181	174	162	148	127	99	79	53	

#### Models 9047C-SP, 9047C-BSP

RPM	Metric Units															
	LPM at 1.4 BAR	LPM at 2.1 BAR	LPM at 2.8 BAR	LPM at 3.4 BAR	LPM at 4.1 BAR	LPM at 4.8 BAR	LPM at 5.5 BAR	LPM at 6.2 BAR	LPM at 6.9 BAR	LPM at 7.6 BAR	LPM at 8.3 BAR	LPM at 8.9 BAR	LPM at 9.7 BAR	LPM at 10.3 BAR	LPM at 11.0 BAR	
450	660	655	640	630	595	530	450	350	230	100	-	-	-	-	-	
500	700	690	680	675	660	650	620	580	500	450	360	260	75	-	-	
540	740	735	735	730	720	705	695	685	660	615	560	480	375	300	200	



9047C, 9047C-SP, and 9047C-BSP

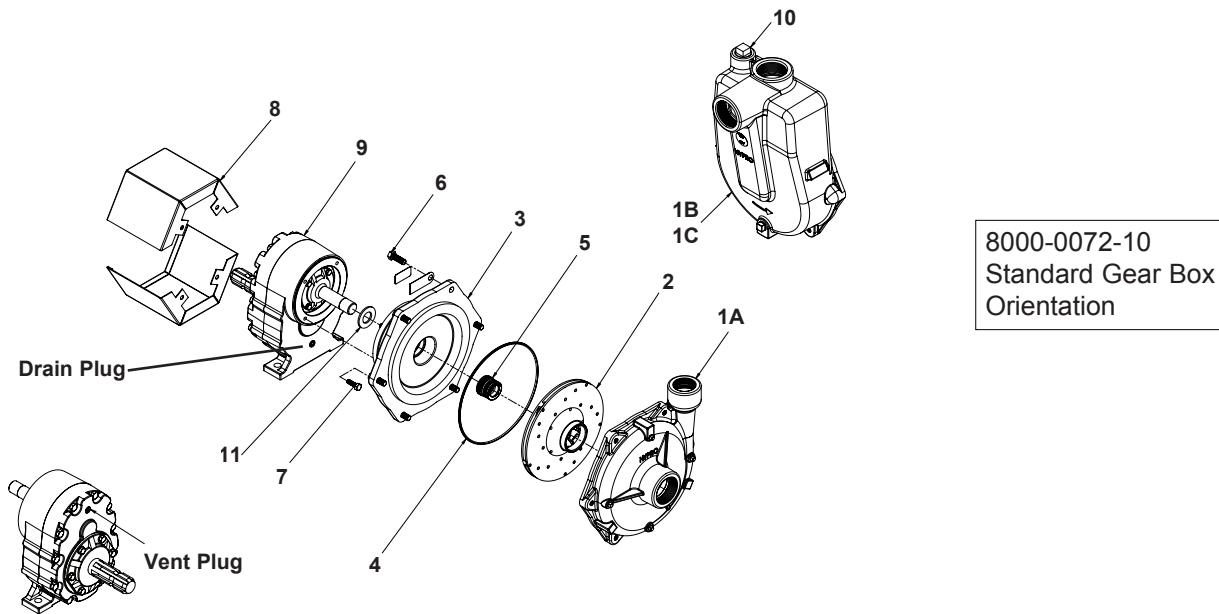

**Series 90030:**  
8000-0072-18  
Inverted Gear Box  
Orientation

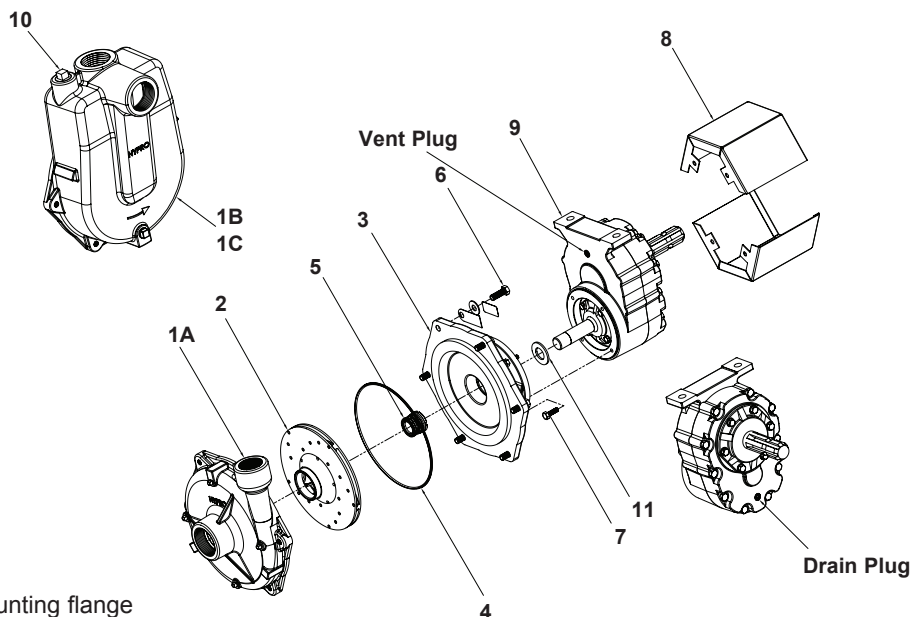

**NOTE:** The weep holes in the mounting flange adapter (Ref. 3) must face downward, regardless of gearbox orientation.

Ref. No.	Qty. Req'd.	Part No.	Description
1A	1	0153-9200C1	Pump Casing (with SS wear ring)
1B	1	0152-9275C2	Pump Casing (Self-Priming Model) - NPT
1C	1	0152-9275C3	Pump Casing (Self-Priming Model) - BSP
2	1	0404-9200P	Impeller (CCW rotation)
3	1	0707-9200C1	Gas Engine Flange (machined)
4	1	1720-0180	O-ring
5	1	2120-0053	Mechanical Seal (Viton)
6	6	2210-0086	Hex Head Capscrew
7	4	2210-0098	Hex Head Capscrew
8	2	2840-0086	Shield, PTO Shaft
9	1	8000-0072-10	Gear Box - 10 oz. (9047C, 9047C-SP, 9047C-BSP)
9	1	8000-0072-18	Gear Box - 18 oz. (90030)
10	1	2406-0036	Pipe Plug
11	1	1410-0091	Slinger Ring

**Seal Kit No. 3430-0779**  
consists of:  
  
(1) Ref. 4 O-ring and (1) Ref. 5 Mechanical Seal

**NOTE:** When ordering parts, give QUANTITY, PART NUMBER, DESCRIPTION, and COMPLETE MODEL NUMBER. Reference numbers are used ONLY to identify parts in the drawing and are NOT to be used as order numbers.

## Notes



## Limited Warranty on Hypro/SHURflo Agricultural Pumps & Accessories

Hypro/SHURflo (hereafter, "Hypro") agricultural products are warranted to be free of defects in material and workmanship under normal use for the time periods listed below, with proof of purchase.

- Pumps: one (1) year from the date of manufacture, or one (1) year of use. This limited warranty will not exceed two (2) years, in any event.
- Accessories: ninety (90) days of use.

This limited warranty will not apply to products that were improperly installed, misapplied, damaged, altered, or incompatible with fluids or components not manufactured by Hypro. All warranty considerations are governed by Hypro's written return policy.

Hypro's obligation under this limited warranty policy is limited to the repair or replacement of the product. All returns will be tested per Hypro's factory criteria. Products found not defective (under the terms of this limited warranty) are subject to charges paid by the returnee for the testing and packaging of "tested good" non-warranty returns.

No credit or labor allowances will be given for products returned as defective. Warranty replacement will be shipped on a freight allowed basis. Hypro reserves the right to choose the method of transportation.

This limited warranty is in lieu of all other warranties, expressed or implied, and no other person is authorized to give any other warranty or assume obligation or liability on Hypro's behalf. Hypro shall not be liable for any labor, damage or other expense, nor shall Hypro be liable for any indirect, incidental or consequential damages of any kind incurred by the reason of the use or sale of any defective product. This limited warranty covers agricultural products distributed within the United States of America. Other world market areas should consult with the actual distributor for any deviation from this document.

### Return Procedures

All products must be flushed of any chemical (ref. OSHA section 1910.1200 (d) (e) (f) (g) (h)) and hazardous chemicals must be labeled/tagged before being shipped\* to Hypro for service or warranty consideration. Hypro reserves the right to request a Material Safety Data Sheet from the returnee for any pump/product it deems necessary. Hypro reserves the right to "disposition as scrap" products returned which contain unknown fluids. Hypro reserves the right to charge the returnee for any and all costs incurred for chemical testing, and proper disposal of components containing unknown fluids. Hypro requests this in order to protect the environment and personnel from the hazards of handling unknown fluids.

Be prepared to give Hypro full details of the problem, including the model number, date of purchase, and from whom you purchased your product. Hypro may request additional information, and may require a sketch to illustrate the problem.

**Contact Hypro Service Department at 800-468-3428 to receive a Return Merchandise Authorization number (RMA#).** Returns are to be shipped with the RMA number clearly marked on the outside of the package. Hypro shall not be liable for freight damage incurred during shipping. Please package all returns carefully. All products returned for warranty work should be sent **shipping charges prepaid** to:

HYPRO / PENTAIR  
Attention: Service Department  
375 Fifth Avenue NW  
New Brighton, MN 55112

For technical or application assistance, call the **Hypro Technical/Application number: 800-445-8360**, or send an email to: **technical@hypropumps.com**. To obtain service or warranty assistance, call the **Hypro Service and Warranty number: 800-468-3428**; or send a fax to the **Hypro Service and Warranty FAX: 651-766-6618**.

\*Carriers, including U.S.P.S., airlines, UPS, ground freight, etc., require specific identification of any hazardous material being shipped. Failure to do so may result in a substantial fine and/or prison term. Check with your shipping company for specific instructions.



375 Fifth Avenue NW • New Brighton, MN 55112  
Phone: (651) 766-6300 • 800-424-9776 • Fax: 800-323-6496  
[www.hypropumps.com](http://www.hypropumps.com)