Original Instruction Manual

KEEP FOR FUTURE REFERENCE

9742P Series
Close-Coupled, AC Electric Motor-Driven,
Self-Priming Poly Centrifugal Pump

Pentair

375 5th Ave., New Brighton, MN 55112

Phone: (651)766-6300 -OR- 800-424-9776 Fax: 800-323-6496

www.hypropumps.com

EU Authorized Representative:

EC	REP
----	-----

 QNET BV Hommerterweg 286
6436 AM Amstenrade, The Netherlands
KvK Zuid-Limburg 14091511

Contents

EU Language	3
Introduction.....	4
Description.....	4
Intended Uses.....	4
Purpose of Manual.....	4
Misuses.....	4
Pump Identification.....	5
Pump Technical Data.....	5
Fluid Pumping Application.....	6
Tools.....	6
Lifting, Transport, and Intermediate Storage.....	6
Assembly and Installation.....	7
Assembly.....	7
Installation.....	7
Plumbing Diagram.....	9
Commissioning, Start-Up, Operation, Shutdown.....	10
Information.....	10
Start-Up, Operation, Shutdown.....	10
Maintenance and Servicing.....	13
Information.....	13
Disposal.....	13
Cleaning.....	13
Maintenance, Routine Servicing, and Inspection.....	14
Troubleshooting.....	15
Replacement Parts.....	16
Declaration of Incorporation.....	17
Warranty.....	Last page

EU Languages

DO NOT attempt to install or operate your pump before reading the manual. Original copies of the manual for Hypro pumps are provided in English. To find a copy in your native language, go to www.hypropumps.com.

Vor dem Ablesen des Handbuches versuchen Sie NICHT, Ihre Pumpe zu installieren. Originale des Handbuches für Hypro-Pumpen werden auf englisch zur Verfügung gestellt. Zu eine Kopie in Ihrer Muttersprache finden, zu www.hypropumps.com zu gehen (German)

N'essayez pas d'installer votre pompe avant de lire le manuel. Des exemplaires originaux du manuel pour des pompes de Hypro sont fournis en anglais. Pour trouver une copie dans votre langue maternelle pour aller a www.hypropumps.com (French)

NON tentare di installare la vostra pompa prima di leggere il manuale. Esempio originale del manuale per Hypro pompe sono in inglese. Per trovare una copia nella vostra lingua andare a www.hypropumps.com (Italian)

Не пытайтесь установить ваш насос до чтения руководства. Оригинальные копии этого руководства для насосы Hypro на английском языке. Найти копию на ваш родной язык перейти к www.hypropumps.com (Russian)

NO intente instalar su bomba antes de leer el manual. Copias originales del manual para Hypro se provee de bombas en ingles. Para encontrar una copia en tu idioma nativo ir a www.hypropumps.com (Spanish)

NIE próbować instalować pompy przed jej odczytaniem instrukcji. Oryginalne kopie instrukcji obsługi pomp Hypro są dostarczane w języku angielskim. Aby uzyskać kopię w twoim ojczystym języku przejdź do www.hypropumps.com (Polish)

Takmaya çalışmayın okumadan önce pompanın manuel. Orijinal kopyalarını Hypro pompaları için İngilizce olarak sunulmuştur. Bir kopyasını bulmak için yerel dil git www.hypropumps.com (Turkish)

Nao tente instalar a bomba antes de ler o manual. As copias originais dos manuais para Hypro bombas sao fornecidos em Ingles. Para encontrar uma copia em sua lingua nativa ir para www.hypropumps.com (Portuguese)

VERGEET NIET uw pomp voor het lezen van het handboek. Exemplaren van de handleiding voor Hypro pompen zijn beschikbaar in het Engels. Op zoek naar een exemplaar in uw eigen taal ga naar www.hypropumps.com (Dutch)

Introduction

Description

Hypro centrifugal pumps are designed for creating and boosting pressure in fluid circuits. The pump operates by taking in fluid from the inlet port after which it is slung by the impeller and expelled through the outlet port. Construction features include housings, impellers and seals which come in a variety of materials in order to be resistant to a range of chemicals. Standard models of centrifugal pumps rotate counterclockwise, when looking at the front of the pump.

Intended Uses

Hypro centrifugal pumps are intended for creating or boosting dynamic pressure in approved fluids. Hypro centrifugal pumps should never be used to pump liquids above 140°F (60°C), or below 34°F (1°C). Any uses outside of those specified in this manual are considered misuses and are prohibited. Contact Hypro technical service with any questions regarding specific acceptable uses.

Purpose of Manual

This manual provides instructions and requirements that must be met when installing, using and maintaining the product(s) identified on the cover.

If the product is sold, the seller must pass this manual onto the new owner.

The following special attention notices are used to notify and advise the user of this product of procedures that may be dangerous to the user or result in damage to the product.

ATTENTION

Attention is used to notify of installation, operation, or maintenance information that is important but not safety related.



This symbol is used to denote the presence of an electrical hazard that will result in personal injury, death or property damage.



This symbol is used to denote the presence of a hazard that will result in personal injury, death or property damage.

California Proposition 65 Warning -- This product and related accessories contain chemicals known to the State of California to cause cancer, birth defects or other reproductive harm.

Misuses

Hypro centrifugal pumps are designed to operate effectively within the specified speed, pressure and environmental ranges. Going outside of these ranges will void the warranty and could cause damage to property, serious injury or death.

- **DO NOT** run the pump higher than the maximum specified pressure.
- **DO NOT** run pumps when the liquid has exceeded the maximum or minimum temperature limit (see Intended Uses).
- **DO NOT** pump non-approved liquids.
- **DO NOT** pump water or other liquids for human consumption.
- **DO NOT** operate any pump under the influence of drugs or alcohol.
- **DO NOT** run the pump dry.
- **DO NOT** run motor above the voltage and current it is rated for.

Pump Identification

Hypro uses serialized labeling to enable users to precisely identify the pump's manufacturing date.

Serial Number:

First and second digits: year (12 = 2012)

Third through fifth digits: consecutive day of the year the pump was manufactured.

Last five digits: Unique number assigned to each pump.

Pump Technical Data

(All specifications and performance data are based on water as a carrier fluid.)

9742P Series

Pump Dimensions				
	9742P-050SPT3 9472P-075SPT3		9742P-050SP	
Dim.	Inch	mm	Inch	mm
A	13.6	346	13.16	346
B	6.4	162	6.4	162
C	12.2	311	12.2	311
D	6.7	171	6.7	171
E	23.7	602	25.2	640
F	5.7	144	5.7	144
G	6.7	170	6.7	170
H	6.7	170	6.7	170
I	10	255	10	255
J	5	128	5	128

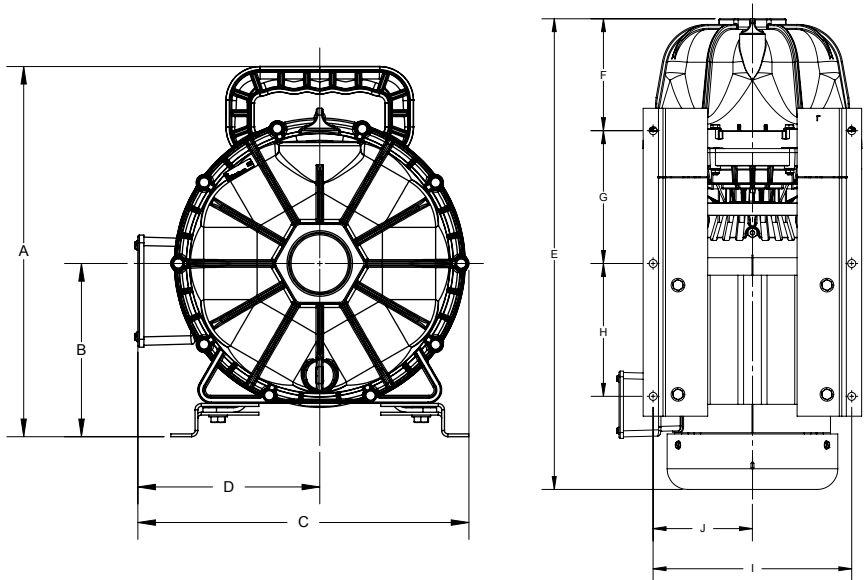

60 Hz

Pump	Max Flow Rate (GPM) [LPM]	Max Pressure (PSI) [BAR]	Ports	Dry Weight (LBS) [KG]	Mounting Bolts	Horsepower	Phase	Voltage (Volts)	Current (Amps)
9742P-050SPT	(150) [568]	(47) [3.2]	2" NPT Inlet & Outlet	(110) [50]	5/16" or M8	5	Single	230	19.4
9742P-050SPT3	(150) [568]	(47) [3.2]		Three			230/460	12.6	
9742P-075SPT3	(188) [712]	(54) [3.7]		Three		230/460	17.4/8.7		

50 Hz

Pump	Max Flow Rate (GPM) [LPM]	Max Pressure (PSI) [BAR]	Ports	Dry Weight (LBS) [KG]	Mounting Bolts	Horsepower	Phase	Voltage (Volts)	Current (Amps)
9742P-050SPT	(120) [454]	(32) [2.2]	2" NPT Inlet & Outlet	(110) [50]	5/16" or M8	3	Single	220	14
9742P-050SPT3	(120) [454]	(32) [2.2]		(90) [41]		4	Three	190/380	11.4/5.7
9742P-075SPT3	(160) [606]	(37) [2.6]		(90) [41]		5	Three	190/380	14.4/7.2

9742P-050SPT &
9742P-050SPT3
METRIC

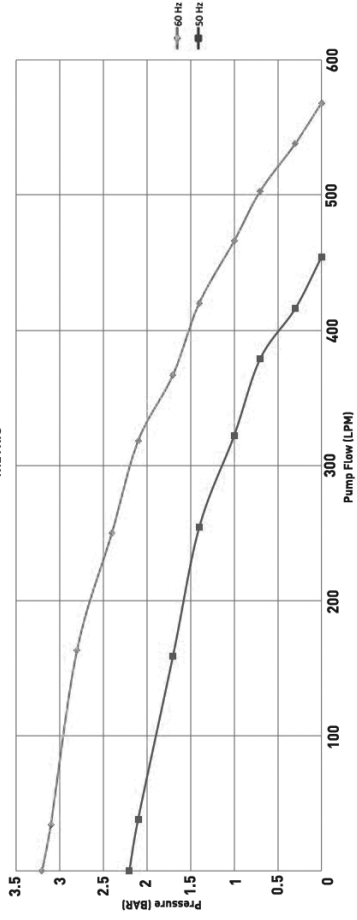

60 Hz		0	0.3	0.7	1	1.4	1.7	2.1	2.4	2.8	3.1	3.2
BAR		0	0.3	0.7	1	1.4	1.7	2.1	2.4	2.8	3.1	3.2
50 Hz		0	0.3	0.7	1	1.4	1.7	2.1	2.2			
LPM		568	538	503	466	420	367	318	250	163	34	0
LPM		454	416	379	322	254	159	38	0			

9742P-075SPT3 METRIC

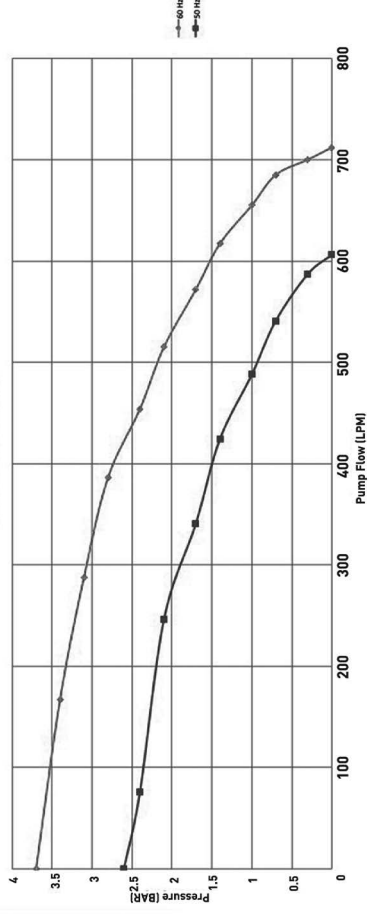

60 Hz		0	0.3	0.7	1	1.4	1.7	2.1	2.4	2.8	3.1	3.4	3.7
BAR		0	0.3	0.7	1	1.4	1.7	2.1	2.4	2.8	3.1	3.4	3.7
50 Hz		0	0.3	0.7	1	1.4	1.7	2.1	2.4	2.6			
LPM		712	700	685	655	617	572	515	454	386	288	167	0
LPM		606	587	541	488	424	341	246	76	0			

9742P-050SPT &
9742P-050SPT3

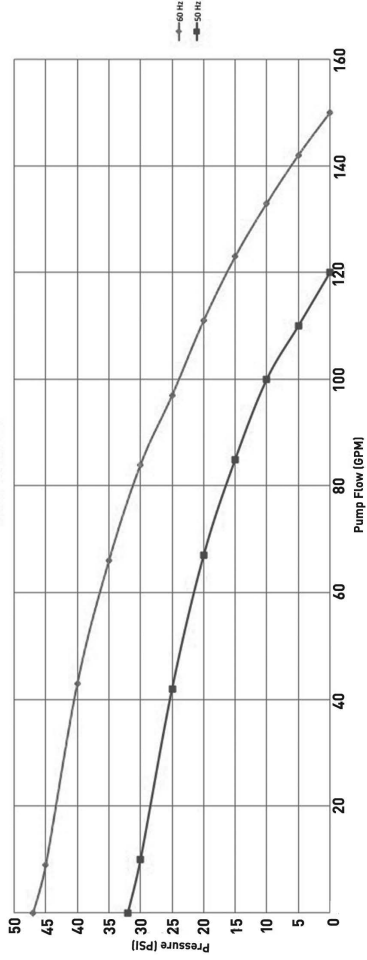

60 Hz		0	5	10	15	20	25	30	35	40	45	47
PSI		0	5	10	15	20	25	30	35	40	45	47
50 Hz		0	5	10	15	20	25	30	32			
GPM		150	142	133	123	111	97	84	66	43	9	0
GPM		120	110	100	85	67	42	10	0			

9742P-075SPT3

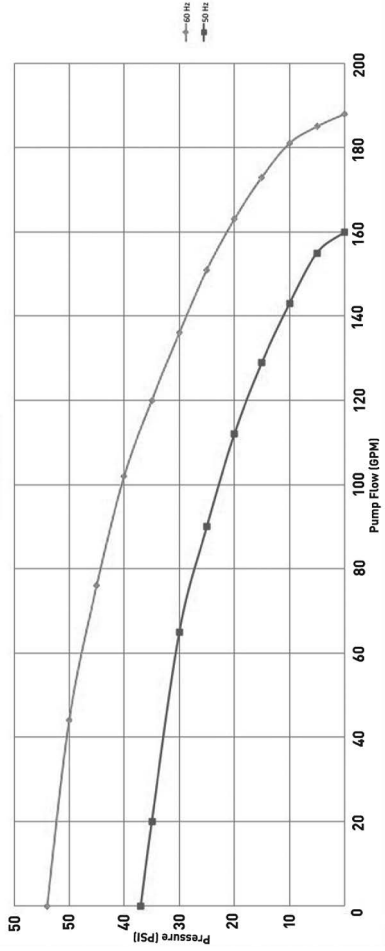

60 Hz		0	5	10	15	20	25	30	35	40	45	50	54
PSI		0	5	10	15	20	25	30	35	40	45	50	54
50 Hz		0	5	10	15	20	25	30	35	37			
GPM		188	185	181	173	163	151	136	120	102	76	44	0
GPM		160	155	143	129	112	90	65	20	0			

Fluid Pumping Applications

Application	Pump Materials Compatibility		
	Impeller	Pump Housing	Seal
	Polypropylene	Polypropylene	Ceramic
Weed Control Chemicals	X	X	X
Insect Control	X	X	X
Brush Control	X	X	X
Pest Control Chemicals and Fumigants	X	X	X
Liquid Fertilizers	X	X	X
Powdered Fertilizers	X	X	X
Fluid Transfer	X	X	X
Acids	X	X	

Table 1

Flammable liquids as well as the following fluids should never be put through any Hypro pump:

- Sewage
- Potable water

Tools

The Hypro centrifugal pumps and mounting assemblies are designed with Imperial (inch) bolts, however, there are many metric (mm) sizes which will work with these mounts. In most cases, an adjustable spanner wrench can also be used.

Lifting, Transport, and Intermediate Storage

Packaging Descriptions and Unpacking Instructions

- Hypro centrifugal pumps are shipped in cardboard boxes for safe transporting.
- When pumps are shipped in large quantities, they may be put on a pallet to allow for easy storage, lifting and handling.
- Before lifting any pump or pallet, determine the weight of the item by looking at the attached packing slips to establish what lifting equipment should be used.
- Before installing the pump, determine if all the components are present and undamaged. If the pump is missing components, contact customer service immediately.
- Once the pump is unpacked, dispose of the packaging in a manner compliant with local and national regulations.

Lifting Instructions

- Before attempting to lift a Hypro pump, ensure that the surrounding working area is free of hazards which could cause injury or damage to property.
- During lifting operations, any personnel not involved in the lift should not enter the working area.
- If lifting hooks, rope or chains are being used for a lift, they must be free of damage and be rated to carry 150% of the weight of the load to be lifted.
-  Always wear steel-toed shoes and cut-resistant gloves when attempting to lift.
- When lifting and carrying, always keep the pump close to your body. (See Figure 1)
- When starting the lift, bend your knees and keep your back straight. (See Figure 1) Tightening the stomach muscles will help keep your back straight.
- During the lift, use your legs to do the work. Never use your back, and make sure your legs are at least shoulder-width apart. (See Figure 1)

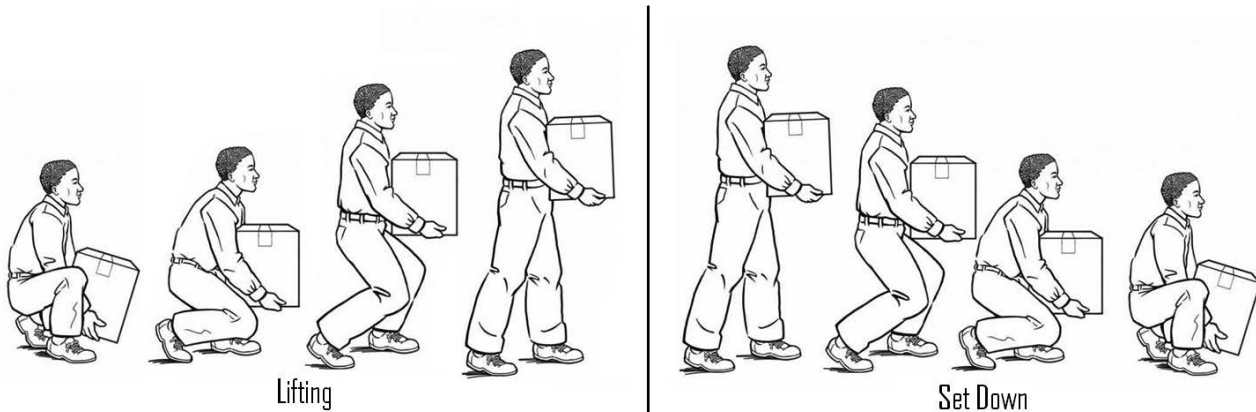

Figure 1

Transport

- All Hypro pumps are capable of being transported by air, sea, rail or motor vehicle. When the pump is shipped, ensure that the pump is moved in accordance with local and national laws and is properly secured to prevent unwanted movement which could cause damage to person or property. Prior to shipping, all fluids should be removed from the pump.

Storage

- New pumps in their boxes can be stored several years as long as the port plugs are not removed. Once the plugs have been removed, if the pump is not to be used for an extended period of time (i.e. more than 30 days), the pump must be winterized as described in the Cleaning section of this manual.

Assembly and Installation

Assembly

- This pump comes completely assembled.

Installation

Before attempting to install your Hypro centrifugal pump, it is imperative to read and understand the following:

- **⚠** Installation of a Hypro pump should only be performed by a technician having the knowledge and skills necessary to install the pump without the risk of property damage or personal injury.
- **⚠** When handling Hypro pumps, one should wear steel-toed shoes and protective gloves in order to protect the feet in the event the pump is dropped and protect the hands from any sharp surfaces on the pump or chemicals.
- **⚠** Pumping systems must be installed in accordance with Hypro installation instructions. Failure to do so will void your warranty and could cause damage to property, serious personal injury, or death.
- **⚠** It is the installer's responsibility to conduct electrical tests in accordance with EN60204-1:2006/A1:2009, or its superseding standard, on finished pump assemblies.
- All connections to electrical components must be number, symbol, or color-coded generally as recommended by EN60204-1:2006/A1:2009, or its superseding standard.
- **⚠** If a rigid plumbing system is to be used on a Hypro centrifugal pump, the system must be properly aligned with the inlet and outlet ports.
- **⚠** When installing, adjusting or removing a Hypro centrifugal pump, ensure that there are no objects which can fall on the installer and make certain that all machinery to which the pump is to be attached is turned off.
- **⚠** Pumps must be installed in a location where they are accessible for any necessary maintenance.
- **⚠** Electrical power cables and pump hoses must be routed where there is no risk or personnel tripping, walking into, or falling because they have been routed in areas where personnel are expected to move. Electrical power cables and pump hoses should be routed according to local and national standards.

- ⚠ It is the installer's responsibility that AC electric-drive motors, Hypro Pumps, and metalwork of support structures are bonded to earth (ground), per local and national standards, to prevent a buildup of static electricity.
- ⚠ When a main electrical supply is needed to power electric-driven motors, installers are responsible for ensuring that a supply disconnect device, capable of isolating the machine from its electricity supply, be provided.
- ⚠ It is the installer's responsibility to conduct electrical tests in accordance with EN60204-1:2006/A1:2009, or its superseding standard, on finished pump assemblies.

Standard Mounting

- In order to prevent injury or damage to property, all Hypro pumps should be properly mounted to a solid base where there is no danger of the pump falling or breaking loose. All Hypro pumps come with mounting holes which allow bolts to be put into the pump so it can be secured to a sturdy base. When mounting your Hypro centrifugal pump, be sure to use bolts and nuts which are compatible with any chemicals that may come into contact with them as well as choosing the correct grade of bolt based on the pump weight and any expected loads. Pumps should be mounted as close to the liquid source as possible. Non self-priming pumps must be mounted below the liquid level to function properly.

Pump Plumbing

- To achieve maximum pump performance the outlet port on the pump should be pointing straight up, and pump inlet and outlet lines should be at least the same size as their respective port. Pump plumbing must be capable of withstanding the maximum suction, and pressure, generated by the pump and should have as few restrictions as possible.
- Ensure plumbing is properly supported so that the pump casing does not carry the weight. Connect either rigid pipe or flexible suction hose to pump suction as shown in Figure A. If hose is selected, hose must be rated to hold the suction vacuum and prevent collapse while the pump is running. Make the suction line a continuous rise from the water source to the pump. High spots can trap air and also make priming difficult. Make sure all connections are tight and free of air leaks.
- Depth of suction inlet at least four (4) times the diameter of suction pipe to avoid forming vortexes.
Example: Pipe x 4 = 8" minimum depth.

Discharge Connections

- Your pump is equipped with a single port discharge. Select the appropriate size for the application. Install a "T" as shown to allow easy priming of the pump without disconnecting the piping, or by using the priming plug on the housing.

Basket Strainer

A basket strainer is to be used when transferring solutions that may contain debris and solids which could become lodged in the pump or damage the impeller. Because of the high flow capacity of this pump, unknown debris could be siphoned off the bottom of the tank. Install the strainer on the suction side of the pump whenever possible to avoid pump damage.

INSTALLATION LOCATION

Place unit as close to water source as possible to minimize suction lift, obtain the best pumping performance, and aid in priming.

ATTENTION: Settling and/or shifting during operation can cause piping to place excessive strain on the pump and may damage pump case. Set pump on hard level surface.

Plumbing Diagram

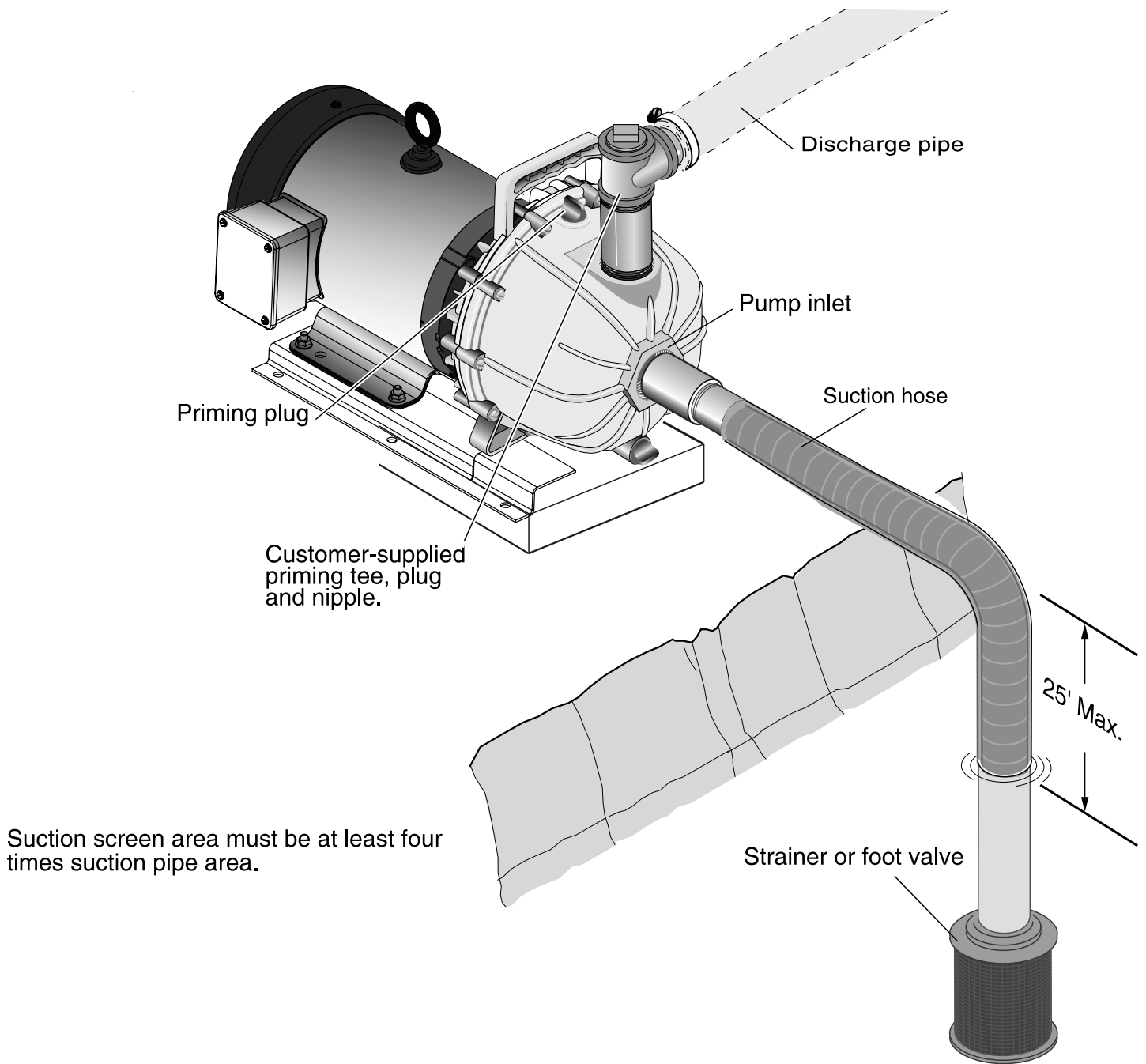









Figure A

Commissioning, Start-Up, Operation, Shutdown

Before attempting to start your pump, the following must be understood and followed to ensure safe operation.

Information

-  When running Hypro centrifugal pumps, it is essential that operators use hearing protection as the sound levels can reach levels of 80 decibels.
-  When handling Hypro pumps, one should wear steel-toed shoes and protective gloves in order to protect the feet in the event the pump is dropped and protect the hands from any sharp surfaces on the pump or chemicals.
-  Only authorized operators having the knowledge and skill necessary to safely use a Hypro pump, or any equipment the pump is connected to, may run the pump.
-  When installing, adjusting or removing a Hypro centrifugal pump, ensure that there are no objects which can fall on the installer and make certain that all machinery to which the pump is to be attached is turned off.
-  Never operate a Hypro centrifugal pump from outside while there is a chance of getting struck by lightning.
-  Never leave electrical wires or plumbing components where they can be a tripping hazard or become entangled in a moving component. Ideally, electrical cables, hoses, pipes and fittings should be routed overhead. In the event electrical wiring must be routed over the ground, operators are required to use rubber ramps if they cross a gangway.
-  Hypro centrifugal pumps should not be used if the ambient light is below 200lux.

 **Only use approved chemicals in your pump. For a complete list of approved chemicals, see the “Fluid Pumping Applications” section. Failure to follow this warning will void your warranty and could lead to property damage, serious injury or death.**

Start-up, Operation, Shutdown

Before Starting the Pump

- Ensure all unnecessary personnel are clear of the area.
- For initial setup and test of your system, it is recommended to start with clean water instead of chemicals, and confirm the system and plumbing connections are leak free.
- Ensure that there is fluid in the source tank or supply line. Do not run dry.
- Check line strainer for debris or clogs. Remove any found.
- Check all plumbing connections to make sure they are tight.
- Check power source and connections.
- Ensure all hoses are properly positioned and are not damaged in any way.

Start-up, Operation, Shutdown

Preparations Before Starting the Pump

Priming the Pump

Make sure all connections are tight and do not leak air. Fill the pump with fluid either through the priming plug or by a tee on the discharge port.

Starting the Pump





1. Turn power switch to the ON position.

Stopping the Pump

Turn power switch to OFF position.

Maintenance and Servicing

Information

-  All maintenance should be done when machinery is stationary and has been isolated from its energy sources. It is dangerous to perform maintenance while machinery is still connected to its power source. Machinery should be isolated from its electrical, hydraulic or gas engine power source.
-  Be sure to release all pressure from the system before performing any sort of maintenance on a Hypro pump.
-  DO NOT perform service or maintenance to the pump, or attached components, until the pump unit is below 109°F(43°C).
- The lubrication of this pump unit has been done at the factory prior to shipping.
-  When handling Hypro pumps, one should wear steel-toed shoes and protective gloves in order to protect the feet in the event the pump is dropped and protect the hands from any sharp surfaces on the pump or chemicals. If the pump is being repaired while the pump is in service, eye protection should also be worn.

Any hazardous liquids should be disposed of in a manner which complies with local and national regulations. Never dump fluids onto the ground.

Disposal

When disposing of a Hypro pump, be sure to remove all fluids from the pump before scrapping. These fluids should be disposed of in a manner which complies with local and national regulations. Never dump fluids onto the ground. Once the pump is free of all fluids, it may be scrapped in accordance with local and national laws.

Cleaning

Your pump will last longer and give best performance when properly taken care of. Proper pump care depends on the liquid being pumped and when the pump will be used again. After each use, flush pump with a neutralizing solution for the liquid just pumped. Follow with a clean water rinse. This is especially important for corrosive chemicals. It is good practice to clean the pump after each use to prevent deposits from forming and damaging the pump. For infrequent use and before long periods of storage, drain pump thoroughly. Open any drain plugs, remove suction hose from liquid, and blow pump dry with air. An antifreeze/rust inhibitor should be injected into the pump before both ports are plugged and the pump is stored. Plug all ports to keep out air until pump is used again.

Extended Storage

For new pump assemblies that have been stored for a year or more, the AC motor should be relubricated.

Maintenance, Routine Servicing, and Inspection

PREVENTATIVE MAINTENANCE CHECKLIST

Check	Every Use	Daily	Weekly	100 Hrs.	Monthly	6 Months
Water Leaks	X	X				
Plumbing			X			

- Each system's maintenance cycle will be exclusive. If system performance decreases, check immediately.
- Duty cycle, temperature, quality, type of fluid being pumped, and inlet feed conditions all affect the life of assemblies and service cycle.

Troubleshooting

Before attempting to service your pump, be sure that it is disconnected from all energy sources.

Symptom	Probable Cause(s)	Corrective Action
<i>Pump does not prime</i>	Leak in suction line	Check hose and fittings for leaks and correct
	Obstruction in suction line	Inspect hose for obstructions and remove
	Suction hose stuck to tank	Cut a notch or "V" in end of suction hose
	Clogged strainer	Check strainer and clean regularly
<i>Low discharge</i>	Blocked suction hose	Inspect suction hose and repair as necessary
	Pump worn	Repair pump
	Undersized suction line	See Installation
<i>Pump will not turn</i>	Impeller plugged	Inspect and clear obstruction
	Power to motor not turned on	Check power circuit and connections

Replacement Parts

The following drawings show the pumps and their replacement parts. **Only genuine replacement parts should be used. Failure to follow this warning can result in damage to property, serious injury or death.** If the pump malfunctions or is defective, it should be sent back to Hypro for service.

9742P Series

Pump Head Kits	
3 Vane - 3430-0690	5 Vane - 3430-0691
Includes items 4-16* and 22-30 *Uses 9A Impeller	Includes items 4-16* and 22-30 *Uses 9B Impeller

NOTE: When ordering parts, give QUANTITY, PART NUMBER, DESCRIPTION, and COMPLETE PUMP MODEL NUMBER. Reference numbers are used ONLY to identify parts in the drawing and are NOT to be used as order numbers.

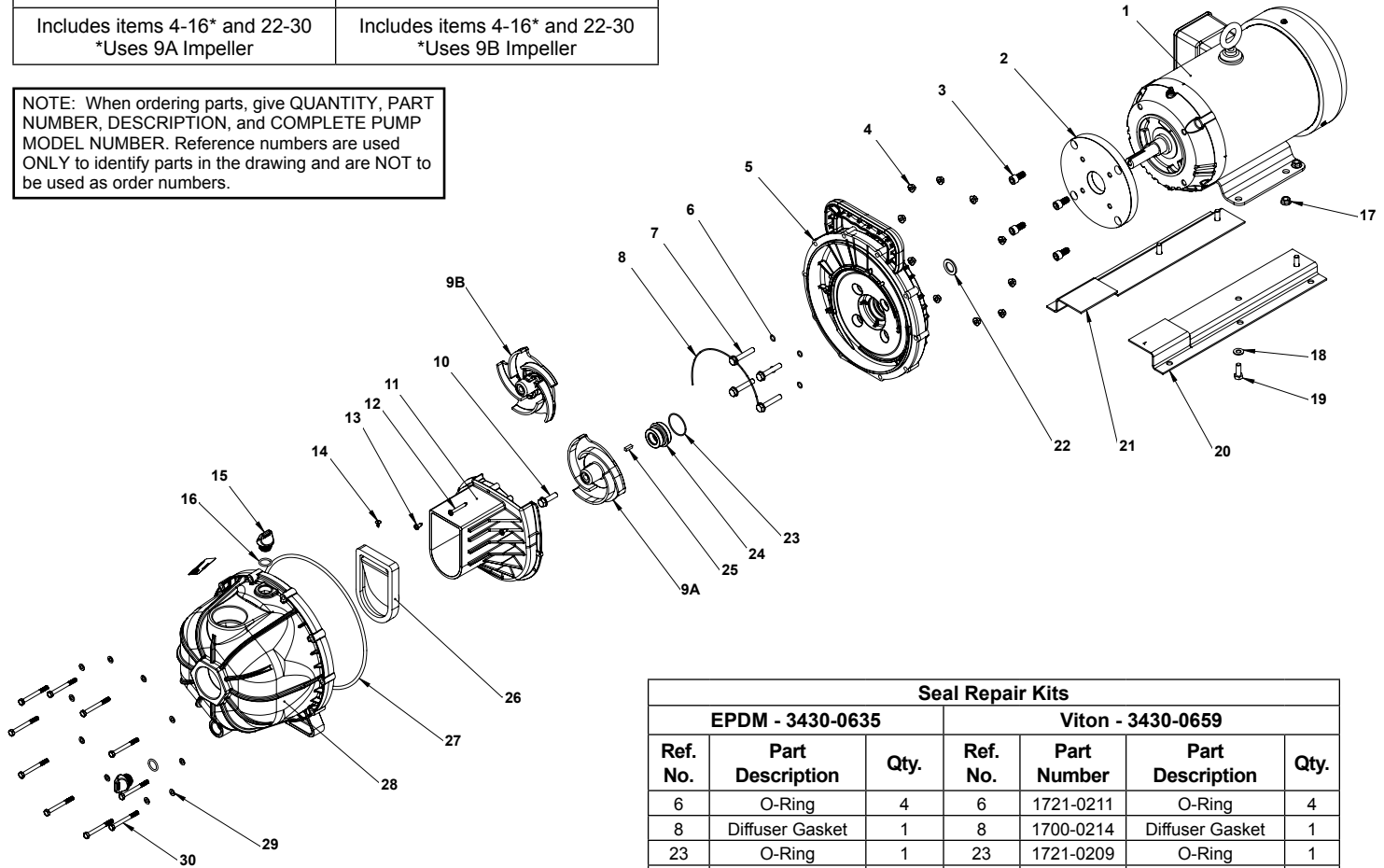

Seal Repair Kits						
EPDM - 3430-0635			Viton - 3430-0659			
Ref. No.	Part Description	Qty.	Ref. No.	Part Number	Part Description	Qty.
6	O-Ring	4	6	1721-0211	O-Ring	4
8	Diffuser Gasket	1	8	1700-0214	Diffuser Gasket	1
23	O-Ring	1	23	1721-0209	O-Ring	1
24	Mechanical Seal	1	24	2120-0045	Mechanical Seal	1
27	O-Ring	1	26	1700-0216	Flapper Valve	1
			27	1721-0210	O-Ring	1

Ref. No.	Qty. Req'd.	Part Number	Part Description
1	1	2580-0003	AC Motor, 5 HP, Three Phase
		2580-0004	AC Motor, 7.5 HP, Three Phase
		2580-0005	AC Motor, 5 HP, Single Phase
2	1	1520-0135	Adapter
3	4	2220-0004	Socket Head Cap Screw
4	10	2250-0087	Hex Flange Nut, M6
5	1	0751-1540P	Mounting Flange
6	4	1720-0013	O-Ring
7	4	2210-0153	Hex Head Cap Screw
8	1	1700-0209	Diffuser Gasket
9A	1	0400-1540P	3-vane Impeller
9B	1	0401-1540P	5-vane Impeller
10	1	2210-0142	Hex Head Cap Screw
11	1	0150-1540P	Diffuser
12	1	2210-0144	Screw
13	2	2210-0145	Screw
14	1	2210-0152	Screw

Ref. No.	Qty. Req'd.	Part Number	Part Description
15	2	2404-0350P	Fill/Drain Plug
16	2	1720-0230	O-Ring
17	4	2250-0060	Hex Flange Nut
18	4	2270-0112	Flat Washer
19	4	2210-0005	Hex Head Cap Screw
20	1	1520-0138	Mount, Left
21	1	1520-0139	Mount, Right
22	1	1410-0083	Slinger Ring
23	1	1720-0231	O-Ring
24	1	2120-0044	Mechanical Seal
25	1	1610-0044	Key
26	1	1700-0208	Flapper Valve
27	1	1720-0244	O-Ring
28	1	0100-1540P	Pump Housing
29	10	2270-0115	Flat Washer
30	10	2210-0141	Hex Head Cap Screw

EC Declaration of Incorporation

Manufacturers Name: Pentair Flow Technologies, LLC
Manufacturers' Address: 375 Fifth Avenue NW,
New Brighton, MN 55112, USA

Declare that the partially complete machinery described below conforms to applicable health and safety requirements of Parts 1 of Annex I of Machinery Directive 2006/42/EC. This partly completed machinery must not be put into service until the equipment into which it is to be incorporated has been declared in conformity with the provisions of this directive. Confidential technical documentation has been compiled as described in Annex VII Part B of Machinery Directive 2006/42/EC and is available to European national authorities on written request. If a request is received, documentation will be transmitted either electronically or by post. Clauses 1.1.4, 1.1.7, 1.1.8 Section 1.2, Clauses 1.3.5, 1.3.6, 1.3.7, 1.3.8.1, 1.3.8.2, 1.3.9, 1.4.1, 1.4.2.1, 1.4.2.2, 1.4.2.3, 1.4.3, 1.5.2, 1.5.7, 1.5.12, 1.5.14, 1.5.16, 1.6.2, 1.7.1.1, 1.7.1.2, 1.7.2, and 1.7.4.2 are clauses of Machinery Directive 2006/42/EC that have not been met, but could be applicable and must be addressed during installation by a third party.

Description: PENTAIR Pump
Type: Roller Pumps
Series Numbers 1502, 1700, 4001, 4101, 6500, 7560, 7700
Type: Centrifugal Pumps
Series Numbers 1442P, 9000, 9202, 9203, 9205, 9206, 9208, 9262, 9263, 9253, 9302, 9303, 9305, 9306, 9307, 9308, 9742P

The following standards have either been referred to or been complied with in part or in full as relevant:

- | | | | |
|-----------------------|------------------|---|---|
| ENISO 12100 | Machinery Safety | - | General principles for design - Risk assessment and risk reduction |
| EN809-1998 + A1 2009 | Machinery Safety | - | Pumps and pump units for liquids - Common safety requirements |
| EN ISO 13732-1 | Machinery Safety | - | Ergonomics of the thermal environment |
| EN ISO 3744:2010 | Acoustics | - | Determination of sound power levels and sound energy levels of noise sources using sound pressure |
| EN ISO 11202/A1 1997 | Machinery Safety | - | Noise emitted by machinery and equipment |
| EN 12162:2001+A1:2009 | Machinery Safety | - | Liquid pumps - Safety requirements -Procedure for hydrostatic testing |
| EN ISO 4254-6:2009 | Machinery Safety | - | Sprayers and liquid fertilizer distributors |
| 97-68-EC + 2010/26/EU | Gas Emission | - | Non-road gas emissions |

Name **Position**

Signature **Date**

Place of Signing.....

 QNET BV
Hommerterweg 286
6436 AM Amstenrade
The Netherlands

Limited Warranty on Hypro/Shurflo Agricultural Pumps & Accessories

Hypro/Shurflo (hereafter, "Hypro") agricultural products are warranted to be free of defects in material and workmanship under normal use for the time periods listed below, with proof of purchase.

- Pumps: one (1) year from the date of manufacture, or one (1) year of use. This limited warranty will not exceed two (2) years, in any event.
- Accessories: ninety (90) days of use.

This limited warranty will not apply to products that were improperly installed, misapplied, damaged, altered, or incompatible with fluids or components not manufactured by Hypro. All warranty considerations are governed by Hypro's written return policy.

Hypro's obligation under this limited warranty policy is limited to the repair or replacement of the product. All returns will be tested per Hypro's factory criteria. Products found not defective (under the terms of this limited warranty) are subject to charges paid by the returnee for the testing and packaging of "tested good" non-warranty returns.

No credit or labor allowances will be given for products returned as defective. Warranty replacement will be shipped on a freight allowed basis. Hypro reserves the right to choose the method of transportation.

This limited warranty is in lieu of all other warranties, expressed or implied, and no other person is authorized to give any other warranty or assume obligation or liability on Hypro's behalf. Hypro shall not be liable for any labor, damage or other expense, nor shall Hypro be liable for any indirect, incidental or consequential damages of any kind incurred by the reason of the use or sale of any defective product. This limited warranty covers agricultural products distributed within the United States of America. Other world market areas should consult with the actual distributor for any deviation from this document.

Return Procedures

All products must be flushed of any chemical (ref. OSHA section 1910.1200 (d) (e) (f) (g) (h)) and hazardous chemicals must be labeled/tagged before being shipped* to Hypro for service or warranty consideration. Hypro reserves the right to request a Material Safety Data Sheet from the returnee for any pump/product it deems necessary. Hypro reserves the right to "disposition as scrap" products returned which contain unknown fluids. Hypro reserves the right to charge the returnee for any and all costs incurred for chemical testing, and proper disposal of components containing unknown fluids. Hypro requests this in order to protect the environment and personnel from the hazards of handling unknown fluids.

Be prepared to give Hypro full details of the problem, including the model number, date of purchase, and from whom you purchased your product. Hypro may request additional information, and may require a sketch to illustrate the problem.

Contact Hypro Service Department at 800-468-3428 to receive a Return Merchandise Authorization number (RMA#). Returns are to be shipped with the RMA number clearly marked on the outside of the package. Hypro shall not be liable for freight damage incurred during shipping. Please package all returns carefully. All products returned for warranty work should be sent **shipping charges prepaid** to:

HYPRO / PENTAIR
Attention: Service Department
375 Fifth Avenue NW
New Brighton, MN 55112

For technical or application assistance, call the **Hypro Technical/Application number: 800-445-8360**, or send an email to: **technical@hypropumps.com**. To obtain service or warranty assistance, call the **Hypro Service and Warranty number: 800-468-3428**; or send a fax to the **Hypro Service and Warranty FAX: 651-766-6618**.

*Carriers, including U.S.P.S., airlines, UPS, ground freight, etc., require specific identification of any hazardous material being shipped. Failure to do so may result in a substantial fine and/or prison term. Check with your shipping company for specific instructions.

Visit www.hypropumps.com/register today to register your product and stay up-to-date on new products and promotional offers.

The following information is required:

Model # _____ Serial # _____