

HYPRO®

Form L-1576
Rev A

Installation Information

- **Pulley Driven** - Mount pulleys as close to pump and motor engine shaft bearings as possible. Check alignment with a straight edge as shown in Fig. 1.
- Make sure that belt has proper tension. (Too much tension will cause bearing wear; too little will cause slippage.) See Fig. 2.

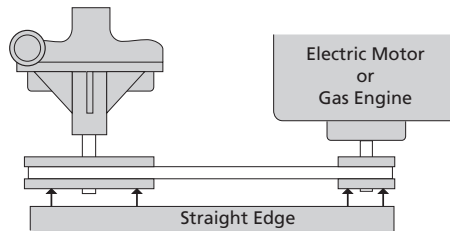

- Check with belt and pulley sources for specific recommendation. To figure proper diameter of pump pulley, multiply motor/engine rpm by diameter of the motor/engine pulley and divide that figure by desired pump speed. Belt and pulley drive systems are typically used to reduce pump speed. For determining proper pulley sizes, use the formula below as a guideline and use "A" or "B" section belts.

$$\frac{\text{Motor RPM}}{\text{Pump RPM}} = \frac{\text{Flow (@ Rated Speed)}}{\text{Flow (Desired)}} = \frac{\text{Pump Pulley Dia.}}{\text{Motor Pulley Dia.}}$$

Example:

- Use a 1725 RPM electric motor to drive a pump at 950 RPM.
- Typically, a pulley diameter on the motor is 3.4 inches. The pump pulley diameter can be determined from the formula above

Push the belt midway between the pulleys, check the deflection (d) and adjust: $d = 0.016 \times L$

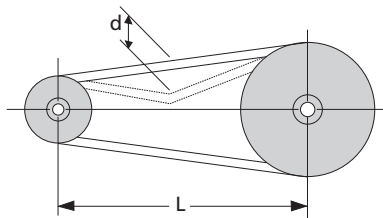

$$\frac{1725 \text{ RPM}}{950 \text{ RPM}} = \frac{\text{Pump Pulley Dia.}}{3.4''}$$

- Solving this equation for the Pump Pulley diameter yields:

$$\frac{1725 \text{ RPM}}{950 \text{ RPM}} \times 3.4'' = 6.2''$$

- Refer to pump performance charts to determine desired speed and to obtain desired maximum flow.

Attention: Note that shaft rotation is clockwise as viewed from the front of the pump. Be sure to drive pump in proper direction.

Clutch Replacement

- On the following pumps, clutch replacement can be performed by removing bolt item24, washer item23 & clutch base item22, refer Fig 1.

9262C-C, 9262S-C, 9262S-CR, 9263C-BT, 9263C-C, 9263C-CB, 9263C-CR, 9263C-CR-B, 9263S-C, 9263S-CR, 9263-CU, 9263C-CR-SP, 9263C-CR-SP-B, 9263C-C-SP AND 9263S-C-SP

- Items 15 & 21 will be reused, refer Fig 2.

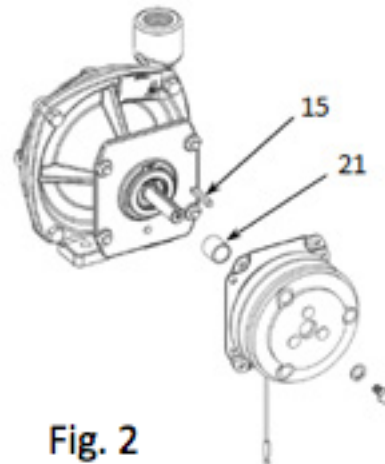
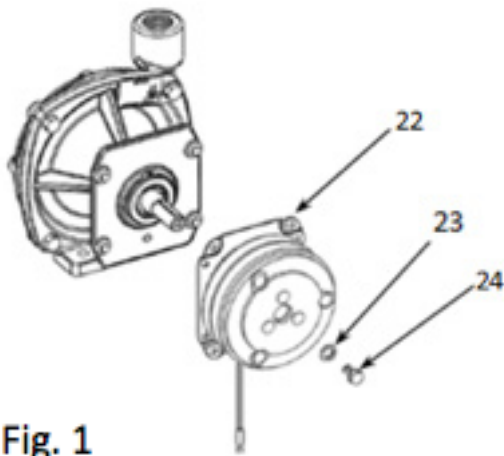

- Clutch assembly should be done in reverse order of the above mentioned steps.
- Test for alignment by hand rotating the clutch to insure there is no rubbing, if rubbing occurs loosen 4 bolts that hold back clutch magnet to adjust , retighten all bolts for final assembly, see Fig 3.

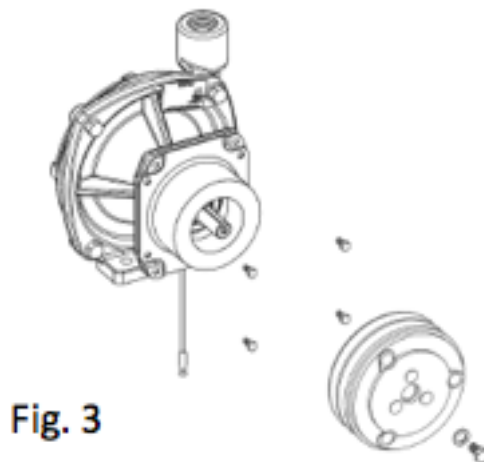

- Reinstall drive belts per instruction, checking alignment and belt tension.

Control Systems

- All pump systems with electric or hydraulic power sources are required to have a control system which meets all local and national standards.
- Overload and short-circuit protection devices should open at a current that is 10% higher than the normal load current.
- For more detail on a typical system installation, see preceding subsections of the "Assembly and Installation" section of this manual.

Replacement Parts

The following drawings show the pumps and their replacement parts. **Only genuine replacement parts should be used, failure to follow this warning can result in damage to property, serious injury or death.** If the pump malfunctions or is defective it should be sent back to Hypro for service.

9262C-C, 9262S-C, 9262S-CR, 9263C-BT, 9263C-C, 9263C-CB, 9263C-CR, 9263C-CR-B, 9263S-C, 9263S-CR, 9263S-CU, 9263C-CR-SP, 9263C-CR-SP-B, 9263C-C-SP, AND 9263S-C-SP

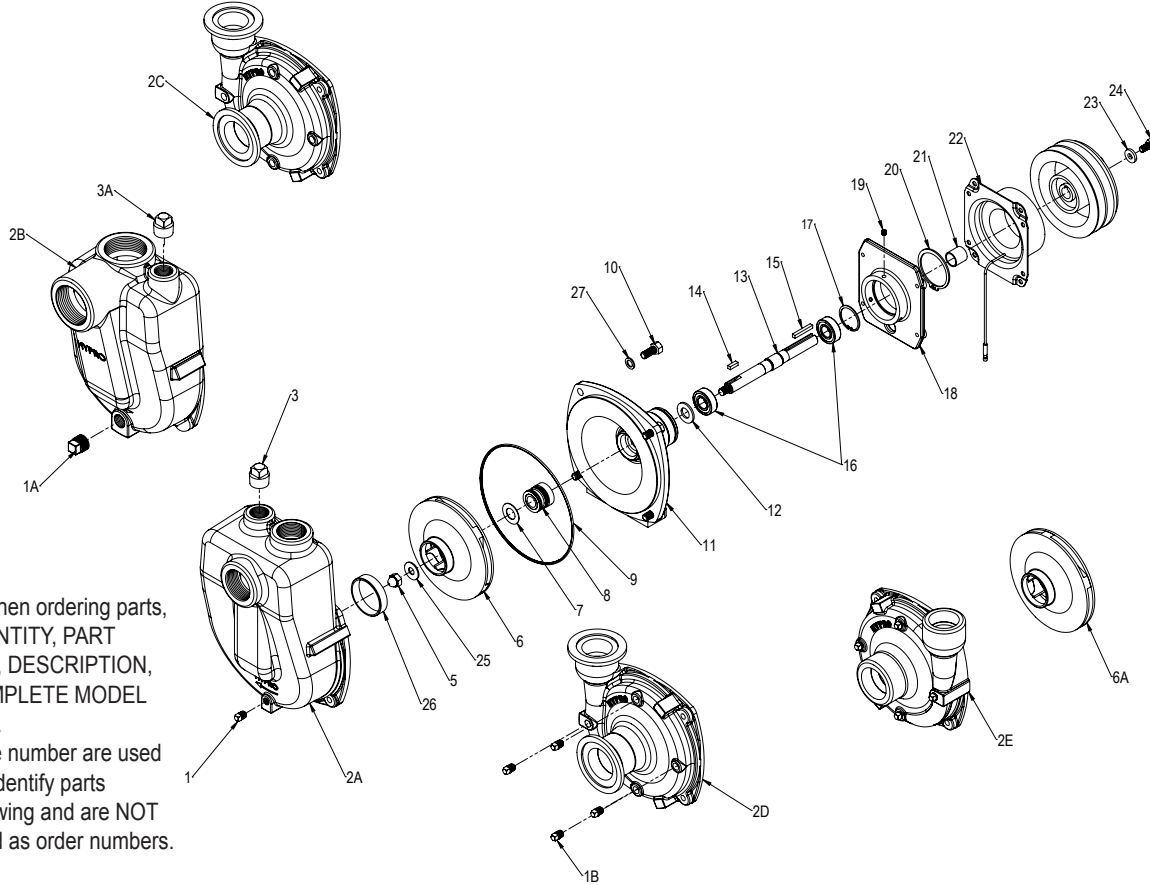

NOTE: When ordering parts, give QUANTITY, PART NUMBER, DESCRIPTION, AND COMPLETE MODEL NUMBER.
Reference number are used ONLY to identify parts in the drawing and are NOT to be used as order numbers.

Seal Kit for Stainless Series
No. 3430-0589 consists of:
(1) Ref. 8 Mechanical Seal
(1) Ref. 9 O-Ring

Standard Seal Kit (Cast)
No. 3430-0332 consists of:
(1) Ref. 7 Gasket
(1) Ref. 8 Mechanical Seal
(1) Ref. 9 O-Ring

Silicon Carbide Kit All Models
No. 3430-0590 consists of:
(1) Ref. 8 Mechanical Seal
(1) Ref. 9 O-Ring
(1) Ref. 22 Washer
(3) Ref. 12 Gasket

Ref. No.	Qty. Req'd.	Part No.	Description
1	1	2406-0007	Pipe Plug
1A	1	2406-0002	Pipe Plug
1B	1	2406-0016	Pipe Plug
2A	1	0150-9070CM	Pump Casting 9263C-C-SP
2AA	1	0150-9070SM	Pump Casting 9263S-C-SP
2B	1	0152-9070CM	Pump Casting 9263C-CR-SP
2C	1	0153-9000CM	Pump Casting 9263C-CU
2CA	1	0153-9000SM	Pump Casting 9263S-CU
2D	1	0150-9200C	Pump Casting 9262C
2DA	1	0156-9200S	Pump Casting 9262S
2E	1	0152-9000C	Pump Casting 9263C-CR
2EA	1	0152-9000S	Pump Casting 9263S-CR
3	1	2406-0001	Pipe Plug
3A	1	7SP34	Pipe Plug
5	1	2253-0002	Nut Cap
5A	1	2253-0006	Nut Cap (Stainless Steel)
6	1	0401-9100P	Impeller
6A	1	0403-9100P	Impeller
7	1	1700-0100	Gasket
8	1	2420-0009	Mechanical Seal
8A	1	2120-0039	Mechanical Seal (Life guard)
9	1	1720-0083	O-Ring

Ref. No.	Qty. Req'd.	Part No.	Description
10	4	2210-0020	Screw
11	1	0750-9200C3	Mounting Flange
11A	1	0756-9200S	Mounting Flange (Stainless Steel)
12	1	1410-0056	Gasket
13	1	0505-9200	Shaft
14	1	1610-0015	Key
15	1	1610-0004	Key
16	2	2000-0010	Ball Bearing
17	1	1820-0013	Retainer Ring
18	1	0753-9200C1	Mounting Flange
19	1	2230-0001	Set Screw
20	1	1810-0036	Retainer Ring
21	1	1410-0107	Spacer
22	1	3430-0930	Kit Clutch
23	1	2270-0092	Washer
24	1	2210-0003	Bolt
25	1	2270-0140	Washer (Stainless pumps only)
26	1	1410-0093	Wear ring

