

HYPRO® 9307 SERIES WITH FORCEFIELD™ TECHNOLOGY

High-Flow Hydraulic-Driven Centrifugal Pumps

Features & Benefits

- NEW ForceField seal technology to protect your pump against today's harshest application environments:
 - Eliminates dry run
 - Eliminates chemical and fertilizer bonding failures
 - Prevents costly in-season downtime
 - Maintenance-free operation
 - Self-regulating chamber designed to provide pressure when needed and safe serviceability when it is not needed
 - Direct drop-in for current 9307 designs
- Components designed for today's high volume liquid fertilizer application on large capacity sprayers:
 - Hydraulic motor includes a case drain for maximum motor life
 - 316 stainless steel impeller
 - Two-piece shaft design includes 416 stainless steel wet end and 8260 hardened steel drive end
 - Bearings designed to handle continuous high volume pump loading
- Capable of flows over 370 GPM (1400 L/min) at 40 PSI (2.8 bar)
- 300 universal flange inlet x 220 universal flange outlet
- One-year warranty that includes pump, motor and seals



The ForceField seal technology is designed to protect against today's harshest chemical and application environments. This technology automatically adjusts seal chamber pressure to the right levels to ensure seal life.



High-flow centrifugal pumps from Hypro handle high-volume spraying applications at increased field speeds, allowing applicators to spray more fields faster, resulting in decreased spraying time and increased profits.



Industry first, 1-Year Warranty includes: Pump, Motor & Seals.

HYPRO® 9307 SERIES WITH FORCEFIELD™ TECHNOLOGY

Specifications

9307CWS-GM12: Performance in water

Hyd. Flow		30 PSI 2.1 BAR		40 PSI 2.8 BAR		50 PSI 3.4 BAR		60 PSI 4.1 BAR		70 PSI 4.8 BAR		80 PSI 5.5 BAR		90 PSI 6.2 BAR		100 PSI 6.9 BAR		110 PSI 7.6 BAR	
GPM	LPM	GPM	LPM	GPM	LPM	GPM	LPM	GPM	LPM	GPM	LPM	GPM	LPM	GPM	LPM	GPM	LPM	GPM	LPM
16	60.6	222	840	180	681	115	435	-	-	-	-	-	-	-	-	-	-	-	-
17	64.4	246	931	212	802	166	628	92	348	-	-	-	-	-	-	-	-	-	-
18	68.1	274	1037	245	927	209	791	157	594	58	220	-	-	-	-	-	-	-	-
19	71.9	302	1143	272	1030	242	916	203	768	150	568	-	-	-	-	-	-	-	-
20	75.7	326	1234	298	1128	271	1026	240	908	196	742	142	537	-	-	-	-	-	-
21	79.5	345	1306	324	1226	297	1124	269	1018	238	901	194	734	140	530	-	-	-	-
22	83.3	345	1306	345	1306	322	1219	297	1124	270	1022	236	893	193	731	138	522	-	-
23	87.1	370	1400	370	1400	344	1302	323	1223	299	1132	273	1033	235	889	194	734	137	519

9307CWS-GM12: Performance in 28% liquid fertilizer

Hyd. Flow		40 PSI 2.8 BAR		50 PSI 3.4 BAR		60 PSI 4.1 BAR		70 PSI 4.8 BAR		80 PSI 5.5 BAR		90 PSI 6.2 BAR		100 PSI 6.9 BAR		110 PSI 7.6 BAR		120 PSI 8.3 BAR		130 PSI 9.0 BAR		140 PSI 9.7 BAR	
GPM	LPM	GPM	LPM	GPM	LPM	GPM	LPM	GPM	LPM	GPM	LPM	GPM	LPM	GPM	LPM	GPM	LPM	GPM	LPM	GPM	LPM	GPM	LPM
16	60.6	228	863	204	772	159	602	100	379	-	-	-	-	-	-	-	-	-	-	-	-	-	-
17	64.4	234	886	219	829	190	719	147	556	49	185	-	-	-	-	-	-	-	-	-	-	-	-
18	68.1	247	935	247	935	223	844	194	734	146	553	49	185	-	-	-	-	-	-	-	-	-	-
19	71.9	255	965	255	965	239	905	221	836	191	723	151	572	55	208	-	-	-	-	-	-	-	-
20	75.7	260	984	260	984	252	954	240	908	220	833	191	723	150	568	63	238	-	-	-	-	-	-
21	79.5	260	984	260	984	254	961	248	939	237	897	224	848	196	742	159	602	87	329	-	-	-	-
22	83.3	260	984	260	984	254	961	248	939	240	908	230	871	214	810	194	734	159	602	101	382	-	-
23	87.1	260	984	260	984	254	961	249	942	249	942	242	916	237	897	227	859	211	799	174	659	133	503

Dimensions		
Ref.	Standard	mm
A	12.23	310.6
B	4.00	101.6
C	3.34	84.8
D	4.63	117.6
E	3.43	87.0
F	5.62	142.7
G	7.26	184.3
H	16.25	412.8
I	4.57	116.2
J	7.21	183.1
K	6.25	158.8
L	2.13	54.0

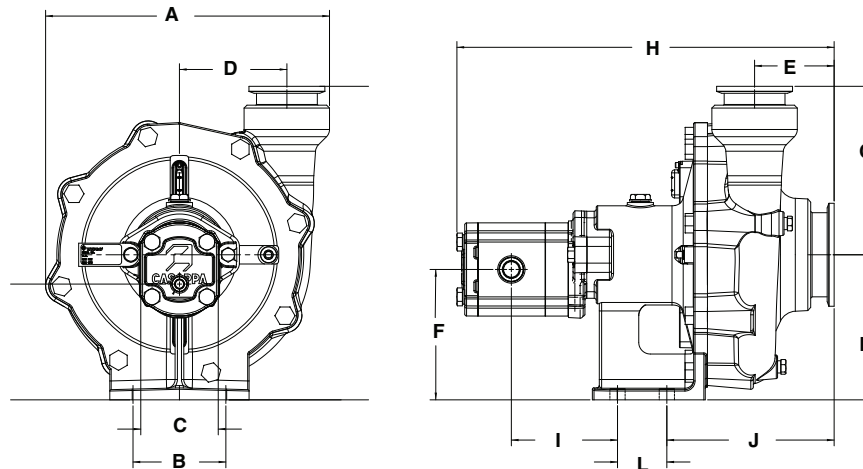

* 3D models available at www.hypropumps.com



375 5TH AVE NW, NEW BRIGHTON, MN 55112 WWW.HYPROPUMPS.COM
 PH: 800-424-9776 ORDERS FAX: 800-323-6496

Because we are continuously improving our products and services, Pentair reserves the right to change specifications without prior notice.

© 2013 Pentair Ltd. All Rights Reserved.

FORM 432 (04/25/13)
 Printed in USA