

# SRA(X)44HH RAIL SYSTEM

## 4SD MODEL PUMP

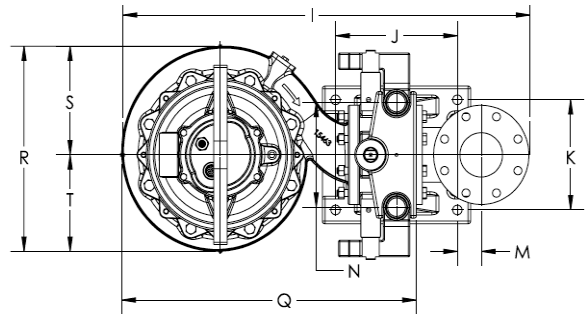
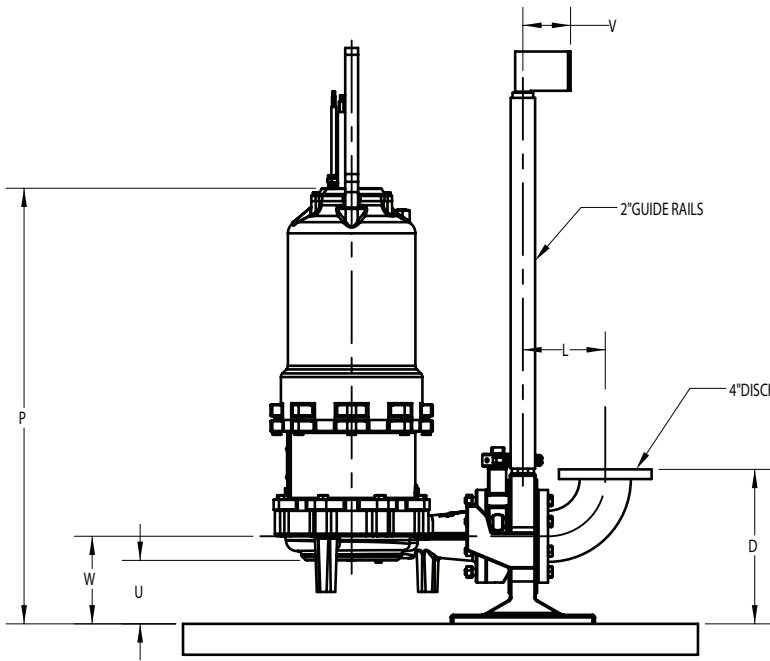

ITEM	DIMENSION
D	15"
I	37"
J	11-1/2"
K	10"
L	8"
M	2-1/4"
N	9-1/2"
P	42-5/16"
Q	26-3/8"
R	16-1/4"
S	8-1/8"
T	8-1/8"
U	6-3/16"
V	4-5/8"
W	8-1/2"

All dimensions in inches.

1101 Myers Parkway  
Ashland, OH 44805  
Ph: 855.274.8948  
Fx: 800.426.9446

490 Pinebush Rd., Unit 4  
Cambridge, Ontario N1T 0A5, Canada  
Ph: 800.363.7867  
Fx: 888.606.5484

[pentair.com/myers](http://pentair.com/myers)