

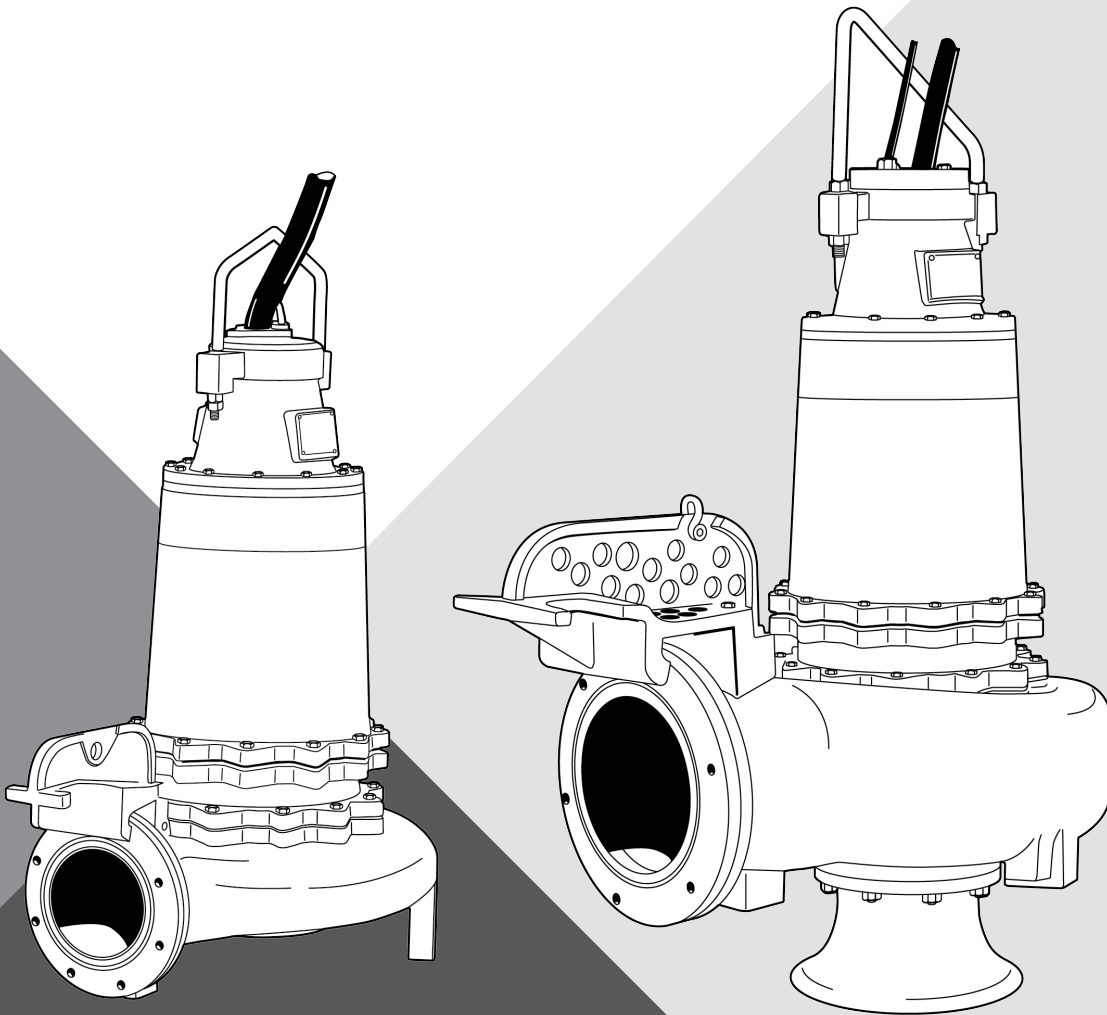

SUBMERSIBLE SOLIDS HANDLING PUMPS

MODELS 4VL(X*), 8SM(X*), 8VL(X*) AND 12VL(X*)

Used in Hazardous Locations Class I, Division 1
For use with product built with USEM motor



INSTALLATION AND OPERATION MANUAL

pentair.com

©2021. All Rights Reserved.



Part # 23833A643 | (09/01/21)

TABLE OF CONTENTS

Safety Information 3

Installation and Operation 4

Wiring Diagrams 6

Repair Parts Index 9

Troubleshooting 15

Warranty..... 16

NOTE! To the installer: Please make sure you provide this manual to the owner of the equipment or to the responsible party who maintains the system.

SAFETY INFORMATION

READ AND FOLLOW SAFETY INSTRUCTIONS!

 This is the safety alert symbol. When you see this symbol on your pump or in this manual, look for one of the following signal words and be alert to the potential for personal injury.

 **DANGER** warns about hazards that will cause serious personal injury, death or major property damage if ignored.

 **WARNING** warns about hazards that can cause serious personal injury, death or major property damage if ignored.

 **CAUTION** warns about hazards that will or can cause minor personal injury or property damage if ignored.

NOTE: indicates special instructions which are important but not related to hazards.

CALIFORNIA PROPOSITION 65 WARNING

 **WARNING** This product and related accessories contain chemicals known to the State of California to cause cancer, birth defects or other reproductive harm.

GENERAL SAFETY

- ◆ Most accidents can be avoided by using common sense.
- ◆ Read the operation and maintenance instruction manual supplied with the pump.
- ◆ Do not wear loose clothing that can become entangled in the impeller or other moving parts.
- ◆ This pump is designed to handle materials that could cause illness or disease through direct exposure.
- ◆ Wear adequate protective clothing when working on the pump or piping.

ELECTRICAL SAFETY

- ◆ To reduce the risk of electrical shock, pump must be properly grounded in accordance with the National Electric Code and all applicable state and local codes and ordinances.
- ◆ To reduce risk of electrical shock, disconnect the pump from the power source before handling or servicing.
- ◆ Any wiring to be done on pumps should be done by a qualified electrician.
- ◆ Never operate a pump with a power cord that has frayed or brittle insulation.
- ◆ Never let cords or plugs lie in water.
- ◆ Never handle connected power cords with wet hands.

PUMPS

- ◆ Pump builds up heat and pressure during operation; allow time for pump to cool before handling or servicing.
- ◆ Only qualified personnel should install, operate or repair pump.
- ◆ Keep clear of suction and discharge openings. Do not insert fingers in pump with power connected.
- ◆ Do not pump hazardous material not recommended for pump (flammable, caustic, etc.).
- ◆ Make sure lifting handles are securely fastened each time before lifting.
- ◆ Do not lift pump by the power cord.
- ◆ Do not exceed manufacturer's recommendation for maximum performance, as this could cause the motor to overheat.
- ◆ Secure the pump in its operating position so it cannot tip over, fall or slide.
- ◆ Keep hands and feet away from impeller when power is connected.
- ◆ Submersible solids handling pumps are not approved for use in swimming pools, recreational water installations, decorative fountains or any installation where human contact with the pumped fluid is common.
- ◆ Do not operate pump without safety devices in place.

IMPORTANT! Myers is not responsible for losses, injury or death resulting from a failure to observe these safety precautions, misuse or abuse of pumps or equipment.

INSTALLATION AND OPERATION

PUMP MODELS

These instructions cover the installation and service of the Myers 4VL, 4VLX, 8VL, 8VLX, 8SM, 8SMX, 12VL, and 12VLX series solids handling submersible pumps. The 4VLX, 8VLX, 8SMX and 12VLX models are Factory Mutual approved and listed hazardous location for hazardous sewage locations Class I, Division 1.

MOTOR HP AND VOLTAGES

These solids handling pumps are offered in three phase wiring configuration only. Voltages and speeds will vary according to the application and can be seen in the tables in this manual.

ELECTRICAL CONTROLS

All of these pump models must be used with a control panel. Myers built control panels are designed to supply the correct electrical controls, motor starting equipment and include the circuitry for moisture and heat sensors. It is recommended that a Myers built control panel is used so that all warranties apply.

GENERAL CONSTRUCTION

The 4VLX, 8VLX, 8SMX and 12VLX motor construction is designed to meet Factory Mutual requirements for Class I, Division 1, sewage applications. These models are certified and nameplated with this approval. The motor chamber and seal chamber are filled with a high dielectric type oil for improved lubrication and heat transfer of the bearings and motor. Since the bearings have been designed for 50,000 hours of life, the oil should never require replacement under normal operating conditions. An air space above the oil level in both the seal and motor chambers is provided to allow the expansion of the oil when at operating temperature. The power and control lines are sealed and strain relieved on the outside entrance with a standard cord grip, and internally through the use of a dielectric potting resin surrounding the electrical wires. All of the pump fasteners and shafts are made from corrosion resistant stainless steel, while the pump castings are made of ASTM A-48 Class 30 cast iron. The wear ring is bronze and all impellers are two vane enclosed solids handling design made of ductile iron.

GENERAL INSTALLATION

Various configurations and methods of plumbing this series of solids handling pumps may be used; however, for ease of installation and service a Myers® rail lift-out system is recommended.

Note: If hazardous location pumps are used in conjunction with a rail lift-out system, it must be a Factory Mutual approved non-sparking, hazardous location system. The Myers approved lift-out models are:

4" Lift-Out
SRAX44HH

8" Lift-Out
SRAX88

12" Lift-Out
SRAX1212

If these guidelines are not followed, the Factory Mutual hazardous location approval is void.

Hazardous Location Service These pumps are to be used for handling sewage, wastewater and storm water only. Do not use in other hazardous locations. These motors must be repaired and serviced only at Myers Authorized Service Centers or at the Myers factory. Any unauthorized field repair voids the warranty, the hazardous location rating, and Factory Mutual approval.

CAUTION After the pump is installed and sewage has entered the basin there are methane and hydrogen sulfide gases, which are poisonous. Never enter a wet well unless the cover is open for a sufficient period of time to allow fresh air into the basin. Myers recommends using the rail lift-out system so that no service is required inside the basin.

OIL FILLED MOTOR

The motor chamber and seal chamber are dielectric oil-filled for good heat transfer and lubrication of bearings and seals. The motor requires no other lubrication. Oil level in the motor housing should be to the bottom of the oil fill plug with the pump in a vertical position, ensuring the upper bearing is submerged in oil. Do not overfill the motor housing since some space is required for oil expansion. Oil level in the seal chamber should be checked with the pump lying horizontally with the fill plug at the top. The oil level should be approximately 3/4" from the outside surface of the housing. Transformer oil should be used and may be purchased from your Myers distributor.

MOTOR

Each motor is provided with heat sensor thermostats attached directly to the motor windings. The thermostats open if the motor windings see excessive heat and, in turn, open the motor contactor in the control panel, breaking the power to the pump. When the motor is stopped due to an overheated condition, it will not start until the motor has cooled and the heat sensor reset button is manually pushed on the front of the Myers control panel. This circuitry is provided in the Myers control panel designs.

The thermostats are set to open at a temperature of 302° F (150°C). The maximum contact rating is 18 amps at 115 VAC and 12 amps at 230 VAC. Motor winding insulation is good for Class F (311°F, 155°C, or higher).

Note: Failure to use proper circuitry and to connect the motor overheat protection in the control panel would negate all warranties and Factory Mutual Approval.

MOTOR SEAL FAILURE WARNING

The seal chamber is oil filled and provided with moisture sensing probes to detect water leakage through the lower shaft seal. The probes can also detect moisture present in the upper motor housing.

INSTALLATION AND OPERATIONS

The presence of water energizes a red seal leak warning light at the control panel. This is a warning light only, and does not stop the motor. It indicates a leak has occurred and the pump must be repaired. Normally, this indicates the outboard seal has leaked. Allowing the unit to operate after the warning could cause upper seal leakage along with motor failure.

The resistance across the moisture seal (seal failure) probes should be checked after a seal leak warning light has lit. This can be done by disconnecting the red and orange control wires from the control panel, and measuring the resistance with an ohmmeter between the wires. If the measured values are below specification, then the pump may have a lower seal failure and require service.

On the Myers hazardous location control panels the seal leak test switch tests the seal leak circuitry continuity. When pushed the seal leak test bulb should light. If the test bulb does not light it means either the wiring circuitry to the seal leak probes has been broken or the bulb has burned out.

Note Myers built control panels supply the correct circuitry for moisture and heat sensor connections. Failure to install the correct circuitry with proper connection would negate warranty and Factory Mutual Approval.

MOTOR POWER CORD, CONTROL CORD AND CORD CAP ASSEMBLY

Each motor power cord has 4 conductors – white, black, red and green. For a three phase motor the red, black and white conductors connect to the three line leads, and the green is connected to a good ground. Interchanging any two leads will reverse the rotation of the motor.

Note: Rotation should be clockwise when observed from the top of the pump. This can be checked by noting which direction the pump torque is upon initial starting. A properly rotating pump will torque counter- clockwise upon start.

The control cable has 5 conductors – black, white, red, orange and green. White and black connect to the heat sensor terminals in the control panels; red and orange connect to the seal failure terminals in the control panel; and the green connects to the ground in the control panel.

The cord cap is epoxy potted. The cord cap provides for a sealed wire connection with terminals so that connections can be made without breaking the motor seal. This allows the cord cap, with cords, to be removed from the motor. An approved hazardous location junction box is required for hazardous locations.

Note: Each cable has a green ground wire and must be properly grounded per the National Electric Code and local codes.

ELECTRICAL MOTOR CONTROLS

All electrical controls and motor equipment should be as specified in these instructions. Consult factory for any acceptable alternatives. For hazardous locations the controls and control panel must be installed outside the hazardous area, or approved hazardous location controls that are intrinsically safe must be used.

JUNCTION BOX

If a junction box is used in a hazardous location, it must be a hazardous location approved type with hazardous location cord connectors. Wires from the junction box must pass through a hazardous location seal connector.

LEVEL SENSING CONTROLS

Intrinsically safe type float controls are recommended for all applications and required for hazardous location service. An intrinsically safe control panel relay will limit the current and voltage to the level controls. A Myers® control panel can be supplied with this type circuitry.

The float level controls maintain the basin sewage water level by controlling pump turn-on and turn-off levels.

1. The lower turn-off control should be set so that the pump stops at approximately the top of the pump. Consult the factory for any settings below this point.
2. The upper turn-on control should be set above the lower turn-off control. The exact height between the controls is determined by the number of pump starts desired and the depth of the basin. A maximum of 10 starts per hour should not be exceeded.
3. The override control is set at a specified height above the upper turn-on control.
4. The alarm control is set about 6" to 12" above the override control.
5. No control should be set above the inlet invert.

ELECTRICAL CONNECTIONS

All electrical wiring must be in accordance with local code and only qualified electricians should make the installations. All wires should be checked for shorts to ground with an ohmmeter or megger after the connections are made. This is important, as one grounded wire can cause failure of the pump, control panel or personal injury.

INSTALLATION AND OPERATIONS

PUMP

The fluid end of the pump is field serviceable and can be disassembled in case of wear, damage, plugging or outboard seal failure. The following will describe the disassembly and reassembly process.

DISASSEMBLY

1. With the pump located in a secure place, remove the bolts fastening the seal housing to the volute. The motor and impeller can now be removed as a unit.
2. Lay the unit down on its side. If the lower seal is to be removed, it is recommended that the oil in the seal chamber be drained. This can be done by removing the lower seal chamber plug and draining the oil into a holding container.
3. To remove the impeller, first remove the bolts from the nose cone. The nose cone will pull off. Using a proper wrench, the impeller retaining bolt and washer must be removed. This may require a piece of wood placed between the vanes to keep the impeller from rotating while removing the bolt. Once the bolt has been removed, tap lightly with a hammer around the outside diameter of the impeller to loosen from tapered shaft and key.

CAUTION The impeller is large and heavy and will need to be supported.

4. If the lower seal needs to be removed, first remove the compression spring that rides between the impeller and the seal assembly. Next remove the compression ring that surrounds the rubber bellows on the rotating portion of the seal assembly. Again using screwdrivers, pry the remaining portion of the rotating seal assembly off the shaft. The ceramic stationary can be removed by placing a screwdriver between the rubber and the ceramic face and then prying, working around the entire diameter. Note, these parts should be discarded and a new seal assembly installed.
5. If the oil in the seal chamber was drained, examine the contents to determine if the upper seal has been damaged. Sign of grit or other abrasive material may indicate that the upper seal has also been damaged. Pressurizing the motor housing assembly between 7 and 10 psi and observing any drop in pressure will indicate if the upper seal is functioning properly.

Note: Upper seal repairs must be done at a Myers Authorized Service Center or at the Myers factory. Any unauthorized field repair voids warranty and the hazardous location approval on the Factory Mutual listed pump.

6. The wear ring can be removed from the volute for repair or replacement.

REASSEMBLY

1. Remove the ceramic portion of the new seal from the package. Brush new dielectric oil around the rubber portion of the stationary assembly and into the pocket in the seal housing. Note, keep the oil off the seal face. Without scratching the seal face, press the ceramic stationary portion into the seal housing with a Myers® seal pusher. With clean cloth, lightly wipe the face of the seal surface to make sure it is dirt free. Remove the rotating portion of the seal from the package and lubricate the inside diameter of the rubber bellows and the outside diameter of the shaft. Place the seal over the shaft (make sure the key is removed). Evenly press on the body of the rotational assembly and slide it down the shaft until the seal faces meet. Once the seal assembly is in position, place the spring over the register on the rotational portion of the seal.
2. Position the key into the seat of the shaft. Align the impeller onto the shaft, making sure that the seal spring is registered properly onto the back side of the impeller. Insert the bolt and washer assembly into the shaft and tighten. Replace the nose cone onto the impeller. The proper Loctite® should be applied to the bolts. Install and tighten.
3. Fill the seal chamber with new dielectric oil. An air gap of 10–15% volume must be left for the expansion of the oil when it is at operating temperature.
4. The wear ring can be aligned with the retaining holes and tapped into place with a soft mallet. The proper Loctite® should be applied to the bolts. Install and tighten.
5. The motor and impeller assembly can be installed into the volute. Make sure that the impeller aligns properly with the volute. Install the volute retaining bolts and tighten.
6. Air tends to trap in the pump case when water rises in the sump or when the pump is lowered into the water after service. To vent off this air, a small hole is drilled into the volute casting. Be sure this vent hole is clean after any service work on pump. Air venting is not a problem after initial start.

WIRING DIAGRAM

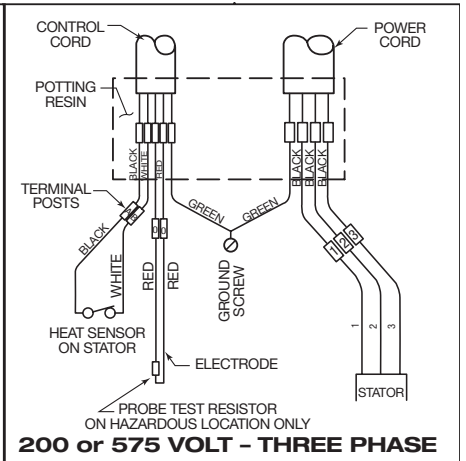
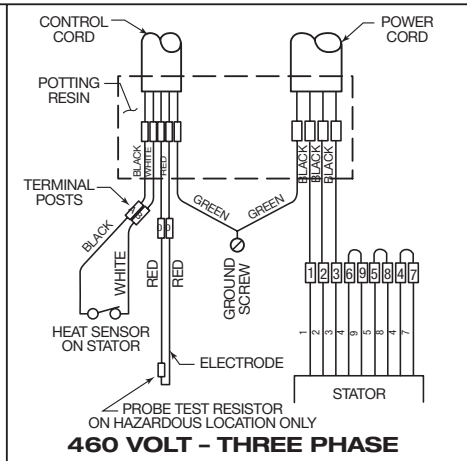
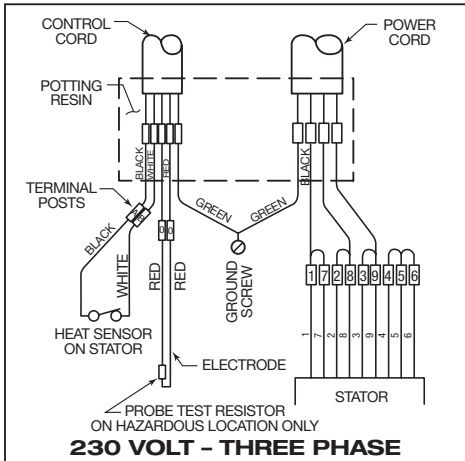
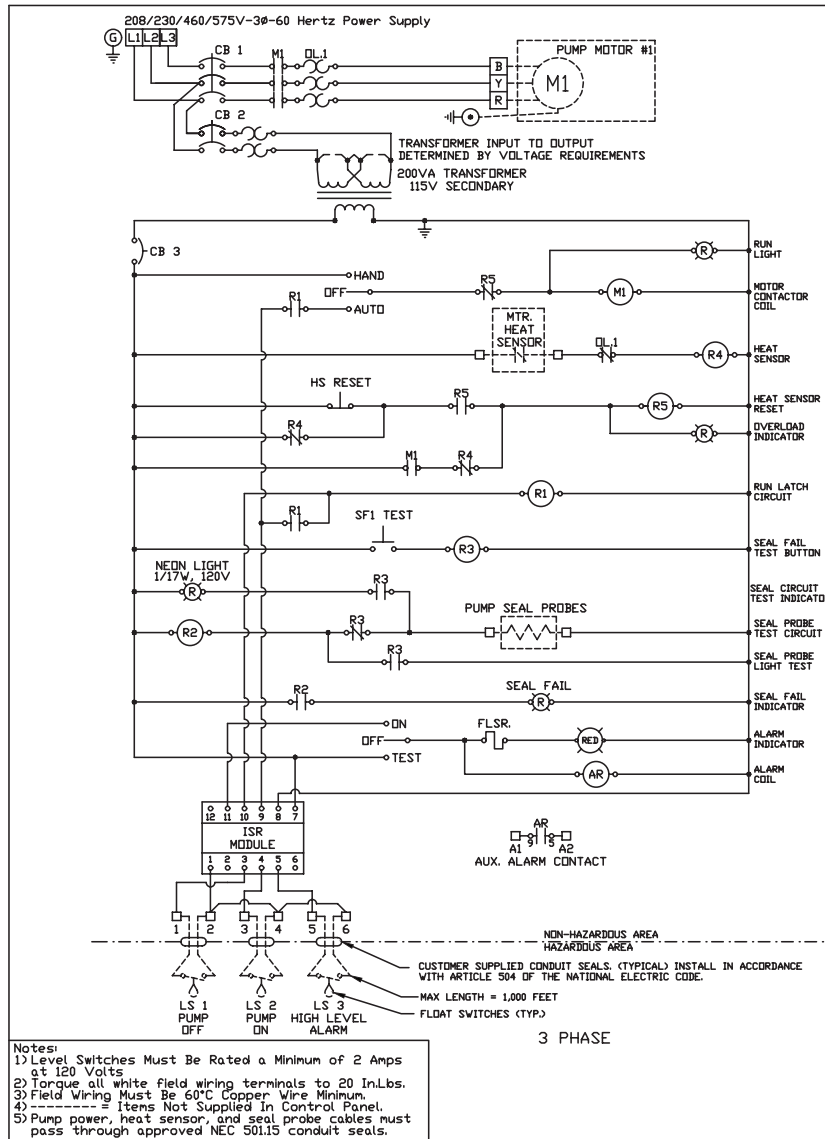

REPAIR PARTS INDEX

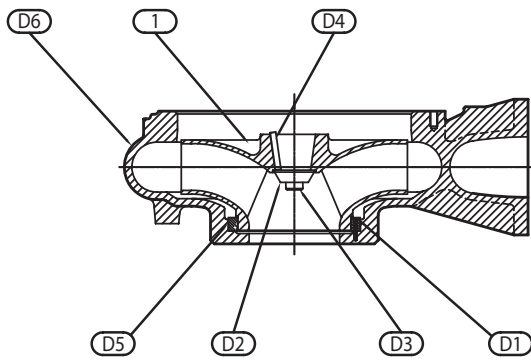

4VL/4VLX

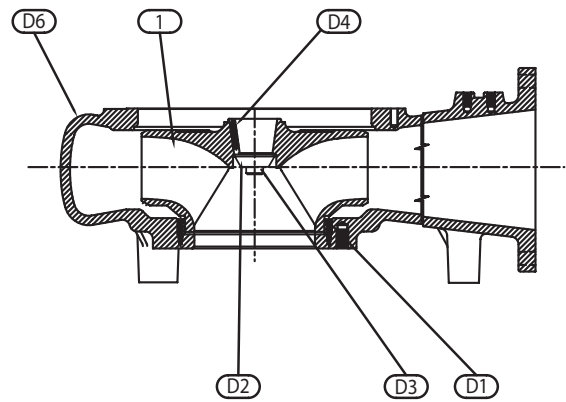

8VL/8VLX

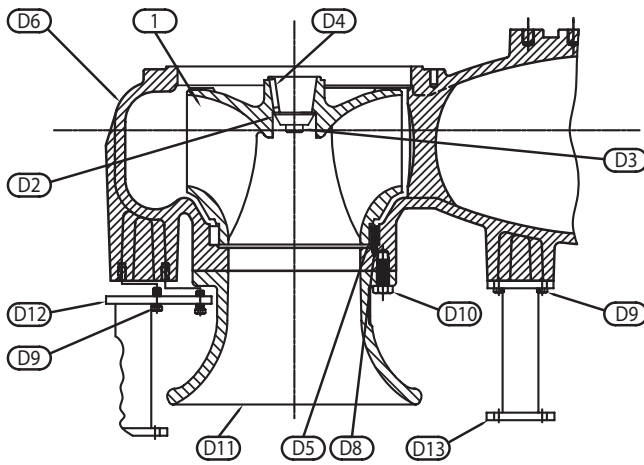

12VL/12VLX

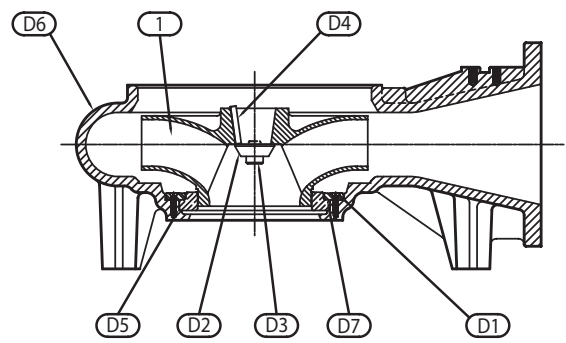

8SM/8SMX

ITEM	DESCRIPTION	ENG. NO.	4VL/4VLX QTY.	8SM/8SMX QTY.	8VL/8VLX QTY.	12VL/12VLX QTY.
D1	SCREW-MACH. (FL HD)	CHARTED	048200111(4)	047560021(4)	001780011(4)	--
D2	WASHER-IMPELLER	CHARTED	019450013	019450013	019450013	019450013
D3	SCREW-CAP	CHARTED	038790021	038790021	038790021	038790021
D4	KEY-SQUARE	CHARTED	05818A048	05818A048	05818A048	05818A048
D5	RING-WEAR	CHARTED	136950003	135350003	083450002	25458D000
D6	VOLUTE	CHARTED	27040F000	073940002	073942002	25457F200
D7	RING-WEAR CLAMP RING	135360003	--	1	--	--
D8	SCREW-CAP SKT HD 1/4-20	06106A045	--	--	--	4
D9	SCREW-CAP HEX 1/2-13 x 1-1/4	19103A052	--	--	--	12
D10	SCREW-CAP HEX 3/4-10 x 1-3/4	19106A017	--	--	--	8
D11	BELL-INLET	25459E000	--	--	--	1
D12	LEG-SUPPORT	CHARTED	--	--	--	25469D000
D13	LEG-SUPPORT, DISCHARGE	CHARTED	--	25469A050	25469A050	25469D001

REPAIR PARTS INDEX

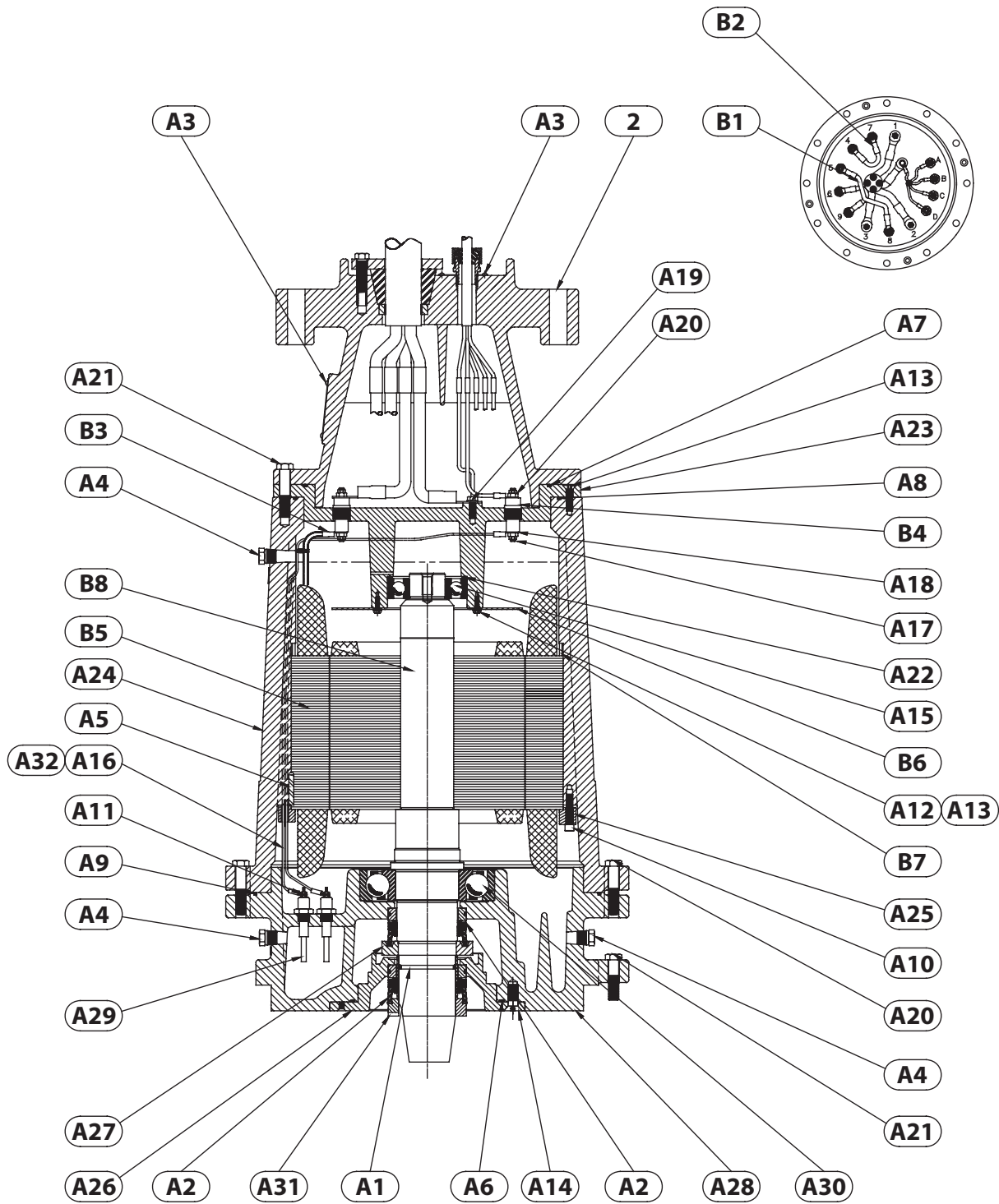

ITEM	DESCRIPTION
"3/8-16"	"20 ft.-lbs."
"1/2-13"	"43 ft.-lbs."
"5/8-11"	"93 ft.-lbs."
"3/4-10"	"128 ft.-lbs."
"7/8-14"	"193 ft.-lbs."

REPAIR PARTS INDEX

ITEM	ENG. NO.	DESCRIPTION	QTY.
A1	001501081	O-RING 1/8 x 2.484 ID VITON®	1
A2	037180051	SEAL-SHAFT 3" TYPE 21 CE/VITON®	2
A3	045800011	SCREW-DRIVE #6	6
A4	05022A062	PLUG-PIPE SST 3/8 SQ. HD	3
A5	05818A050	KEY SQ. 1/4	1
A6	05876A127	O-RING 1/8 x 7-1/4 ID	1
A7	05876A178	O-RING .139 x 12 ID	1
A8	05876A179	O-RING .139 x 13 ID	1
A9	05876A180	O-RING 3/16 x 16-1/2 ID	1
A10	06106A016	SCREW-CAP SKT HD. 5/16-18 x 1-1/2	8
A11	06107A010	WASHER-LOCK #6	2
A12	06107A015	WASHER-LOCK #10	4
A13	07597A017	SCREW-MACHINE FLT HD HEX SKT 5/16-18 x 1	4
A14	07597A034	SCREW-MACHINE FLT HD HEX SKT 7/16-20 x 1	6
A15	08565A026	BEARING-BALL (UPPER)	1
A16	09859A821	WIRE w/TERMINAL 14 GA. RED	2
A17	11904A005	NUT-LOCK SST 1/4-20	26
A18	12074A038	TERMINAL-RING TONGUE 1/4 STUD 16-14 WIRE	2
A19	19099A029	SCREW-CAP HEX 1/4 SST x 5/8	1
A20	19103A048	SCREW-CAP HEX 1/2-13 x 2-1/2	12
A21	19103A049	SCREW-CAP HEX 1/2-13 x 2-1/4	12
A22	19331A009	WASHER-SPRING WAVE 3.937 OD	2
A23	25257D000	PLATE-TERMINAL	1
A24	25258F300	HOUSING-MOTOR	1
A25	25259D000	RETAINER-MOTOR	4
A26	25261D000	PLATE-SEAL	1
A27	25262C011	SEAL-RING	1
A28	25264F000	HOUSING-SEAL	1
A29	25455A000	ELECTRODE; SENSOR-WATER	2
A30	25833A004	BEARING-BALL (LOWER)	1
A31	28142B000	SLEEVE-SHAFT	1
A32	22912A000	RESISTOR(HAZARDOUS LOCATION ONLY)	1

REPAIR PARTS INDEX

870 RPM

ITEM	DESCRIPTION	15-20 HP 200/3/60	15-20 HP 230/3/60	15-20 HP 460/3/60	15-20 HP 575/3/60	25 HP 200/3/60	25-30 HP 230/3/60	25-30 HP 460/3/60	25-30 HP 575/3/60
B1	WIRE w/TERMINAL	--	--	09859A785(1)	--	--	--	09859A785(1)	--
B2	WIRE w/TERMINAL	--	09859A793(5)	09859A793(2)	--	--	09859A825(5)	09859A793(2)	--
B3	TERMINAL-RING	12074A036(3)	12074A037(9)	12074A037(9)	12074A037(3)	12074A036(3)	12074A028(9)	12074A028(9)	12074A037(3)
B4	TERMINAL-ELECTRICAL FAB	23555A000	23555A000	23555A000	23555A000	23555A000	23555A000	23555A000	23555A000
B5	STATOR	141632031	141630031	141630031	141636031	141622031	141620031	141620031	141636031
B6	GUARD-WIRE	25453B000	25453B000	25453B000	25453B000	25453B000	25453B000	25453B000	25453B000
B7	RING-SPACER	25465D003	25465D003	25465D003	25465D003	25465D001	25465D001	25465D001	25465D001
B8	ROTOR w/SHAFT	26892D100	26892D100	26892D100	26892D100	26892D101	26892D101	26892D101	26892D101

1150 RPM

ITEM	DESCRIPTION	30-40 HP 230/3/60	30-40 HP 460/3/60	30-40 HP 575/3/60	50 HP 230/3/60	50 HP 460/3/60	50 HP 575/3/60	60-75 HP 460/3/60	60-75 HP 575/3/60
B1	WIRE w/TERMINAL	--	09859A785(1)	--	--	09859A785(1)	--	--	--
B2	WIRE w/TERMINAL	09859A825(5)	09859A793(2)	--	09859A825(3)	09859A793(2)	--	--	09859A793(3)
B3	TERMINAL-RING	12074A036(9)	12074A036(9)	12074A028(3)	12074A036(9)	12074A036(9)	12074A028(3)	12074A036(3)	12074A028(6)
B4	TERMINAL-ELECTRICAL FAB	23555A000	23555A000	23555A000	23555A000	23555A000	23555A000	23555A000	23555A000
B5	STATOR	141610031	141610031	141616031	141600031	141600031	141606031	141590031	141596031
B6	GUARD-WIRE	25453A000	25453A000	25453A000	25453A000	25453A000	25453A000	25453A000	25453A000
B7	RING-SPACER	25465D002	25465D002	25465D002	25465D000	25465D000	25465D000	--	--
B8	ROTOR w/SHAFT	26892D102	26892D102	26892D102	26892D103	26892D103	26892D103	26892D104	26892D104

1750 RPM

ITEM	DESCRIPTION	50 HP 460/3/60	50 HP 575/3/60	60 HP 460/3/60	60 HP 575/3/60	75 HP 460/3/60	75 HP 575/3/60	100-125 HP 460/3/60	100-125 HP 575/3/60
B2	WIRE w/TERMINAL	--	--	--	--	--	--	09859A825(3)	09859A825(3)
B3	TERMINAL-RING	12074A036	12074A036	12074A036	12074A036	12074A036(3)	12074A036(3)	12074A036(6)	12074A028(6)
B4	TERMINAL-ELECTRICAL FAB	23555A000	23555A000	23555A000	23555A000	23555A000	23555A000	23555A000	23555A000
B5	STATOR	141580031	141586031	141580031	141586031	141580031	141586031	141570031	141576031
B6	GUARD-WIRE	25453B001	25453B001	25453B001	25453B001	25453B001	25453B001	25453B001	25453B001
B8	ROTOR w/SHAFT	26892D105	26892D105	26892D105	26892D105	26892D105	26892D105	26892D105	26892D105

REPAIR PARTS INDEX

4VL/4VLX – 1750 RPM

DESCRIPTION ORDINARY	DESCRIPTION HAZARDOUS	HP	VOLT/PHASE	TRIM	ITEM #1 IMPELLER	ITEM #2 ORDINARY	ITEM #2 HAZARDOUS
4VL500M4-43	4VLX500M4-43	50	460/3	12	135321132	25256D038	25256D638
4VL500M4-53	4VLX500M4-53	50	575/3	12	135321132	25256D037	25256D637
4VL600M4-43	4VLX600M4-43	60	460/3	12.5	135321112	25256D035	25256D635
4VL600M4-53	4VLX600M4-53	60	575/3	12.5	135321112	25256D038	25256D638
4VL750M4-43	4VLX750M4-43	75	460/3	13	135321092	25256D036	25256D636
4VL750M4-53	4VLX750M4-53	75	575/3	13	135321092	25256D035	25256D635
4VL1000M4-43	4VLX1000M4-43	100	460/3	14	135321052	25256D034	25256D634
4VL1000M4-53	4VLX1000M4-53	100	575/3	14	135321052	25256D036	25256D636
4VL1250M4-43	4VLX1250M4-43	125	460/3	15	135321012	25256D034	25256D634
4VL1250M4-53	4VLX1250M4-53	125	575/3	15	135321012	25256D034	25256D634

8SM/8SMX – 1750 RPM

DESCRIPTION ORDINARY	DESCRIPTION HAZARDOUS	HP	VOLT/PHASE	TRIM	ITEM #1 IMPELLER	ITEM #2 ORDINARY	ITEM #2 HAZARDOUS
8SM750M4-43	8SMX750M4-43	75	460/3	13	135320052	25256D036	25256D636
8SM750M4-53	8SMX750M4-53	75	575/3	13	135320052	25256D035	25256D635
8SM1000M4-43	8SMX1000M4-43	100	460/3	14	135320012	25256D034	25256D634
8SM1000M4-53	8SMX1000M4-53	100	575/3	14	135320012	25256D036	25256D636
8SM1250M4-43	8SMX1250M4-43	125	460/3	14.5	135320082	25256D034	25256D634
8SM1250M4-53	8SMX1250M4-53	125	575/3	14.5	135320082	25256D034	25256D634

8VL/8VLX – 1750 RPM

DESCRIPTION ORDINARY	DESCRIPTION HAZARDOUS	HP	VOLT/PHASE	TRIM	ITEM #1 IMPELLER	ITEM #2 ORDINARY	ITEM #2 HAZARDOUS
8VL750M4-43	8VLX750M4-43	75	460/3	12 x 11	25252D560	25256D036	25256D636
8VL750M4-53	8VLX750M4-53	75	575/3	12 x 11	25252D560	25256D035	25256D635
8VL1000M4-43	8VLX1000M4-43	100	460/3	13 x 12	25252D558	25256D034	25256D634
8VL1000M4-53	8VLX1000M4-53	100	575/3	13 x 12	25252D558	25256D036	25256D636
8VL1250M4-43	8VLX1250M4-43	125	460/3	14 x 13	25252D555	25256D034	25256D634
8VL1250M4-53	8VLX1250M4-53	125	575/3	14 x 13	25252D555	25256D034	25256D634

REPAIR PARTS INDEX

8VL/8VLX – 1150 RPM

DESCRIPTION ORDINARY	DESCRIPTION HAZARDOUS	HP	VOLT/PHASE	TRIM	ITEM #1 IMPELLER	ITEM #2 ORDINARY	ITEM #2 HAZARDOUS
8VL300M6-23	8VLX300M6-23	30	230/3	13 x 12	25252D558	25256D035	25256D635
8VL300M6-43	8VLX300M6-43	30	460/3	13 x 12	25252D558	25256D037	25256D637
8VL300M6-53	8VLX300M6-53	30	575/3	13 x 12	25252D558	25256D037	25256D637
8VL400M6-23	8VLX400M6-23	40	230/3	14.13 x 13.13	25252D554	25256D036	25256D636
8VL400M6-43	8VLX400M6-43	40	460/3	14.13 x 13.13	25252D554	25256D038	25256D638
8VL400M6-53	8VLX400M6-53	40	575/3	14.13 x 13.13	25252D554	25256D037	25256D637
8VL500M6-23	8VLX500M6-23	50	230/3	15 x 14	25252D555	25256D034	25256D634
8VL500M6-43	8VLX500M6-43	50	460/3	15 x 14	25252D555	25256D038	25256D638
8VL500M6-53	8VLX500M6-53	50	575/3	15 x 14	25252D555	25256D038	25256D638
8VL600M6-43	8VLX600M6-43	60	460/3	15	25252D550	25256D035	25256D635
8VL600M6-53	8VLX600M6-53	60	575/3	15	25252D550	25256D038	25256D638

8VL/8VLX – 870 RPM

DESCRIPTION ORDINARY	DESCRIPTION HAZARDOUS	HP	VOLT/PHASE	TRIM	ITEM #1 IMPELLER	ITEM #2 ORDINARY	ITEM #2 HAZARDOUS
8VL150M8-03	8VLX150M8-03	15	200/3	13.38 x 12.38	25252D557	25256D038	25256D638
8VL150M8-23	8VLX150M8-23	15	230/3	13.38 x 12.38	25252D557	25256D037	25256D637
8VL150M8-43	8VLX150M8-43	15	460/3	13.38 x 12.38	25252D557	25256D030	25256D630
8VL150M8-53	8VLX150M8-53	15	575/3	13.38 x 12.38	25252D557	25256D030	25256D630
8VL200M8-03	8VLX200M8-03	20	200/3	14.88 x 13.88	25252D552	25256D038	25256D638
8VL200M8-23	8VLX200M8-23	20	230/3	14.88 x 13.88	25252D552	25256D038	25256D638
8VL200M8-43	8VLX200M8-43	20	460/3	14.88 x 13.88	25252D552	25256D037	25256D637
8VL200M8-53	8VLX200M8-53	20	575/3	14.88 x 13.88	25252D552	25256D030	25256D630
8VL250M8-03	8VLX250M8-03	25	200/3	15	25252D550	25256D035	25256D635
8VL250M8-23	8VLX250M8-23	25	230/3	15	25252D550	25256D035	25256D635
8VL250M8-43	8VLX250M8-43	25	460/3	15	25252D550	25256D037	25256D637
8VL250M8-53	8VLX250M8-53	25	575/3	15	25252D550	25256D037	25256D637

NOTE: Standard non-overloading impeller diameters and 35' cords shown.

REPAIR PARTS INDEX

12VL/12VLX – 1150 RPM

DESCRIPTION ORDINARY	DESCRIPTION HAZARDOUS	HP	VOLT/PHASE	TRIM	ITEM #1 IMPELLER	ITEM #2 ORDINARY	ITEM #2 HAZARDOUS
12VL400M6-23	12VLX400M6-23	40	230/3	12.5	25456E558	25256D036	25256D636
12VL400M6-43	12VLX400M6-43	40	460/3	12.5	25456E558	25256D038	25256D638
12VL400M6-53	12VLX400M6-53	40	575/3	12.5	25456E558	25256D037	25256D637
12VL500M6-23	12VLX500M6-23	50	230/3	13.06	25456E555	25256D034	25256D634
12VL500M6-43	12VLX500M6-43	50	460/3	13.06	25456E555	25256D035	25256D635
12VL500M6-53	12VLX500M6-53	50	575/3	13.06	25456E555	25256D038	25256D638
12VL600M6-43	12VLX600M6-43	60	460/3	16.63	25456E553	25256D035	25256D635
12VL600M6-53	12VLX600M6-53	60	575/3	13.63	25456E553	25256D038	25256D638
12VL750M6-43	12VLX750M6-43	75	460/3	14..13	25456E551	25256D036	25256D636
12VL750M6-53	12VLX750M6-53	75	575/3	14.13	25456E551	25256D035	25256D635

12VL/12VLX – 870 RPM

DESCRIPTION ORDINARY	DESCRIPTION HAZARDOUS	HP	VOLT/PHASE	TRIM	ITEM #1 IMPELLER	ITEM #2 ORDINARY	ITEM #2 HAZARDOUS
12VL150M8-03	12VLX150M8-03	15	200/3	12.38	25456E559	25256D038	25256D638
12VL150M8-23	12VLX150M8-23	15	230/3	12.38	25456E559	25256D037	25256D637
12VL150M8-43	12VLX150M8-43	15	460/3	12.38	25456E559	25256D030	25256D630
12VL150M8-53	12VLX150M8-53	15	575/3	12.38	25456E559	25256D030	25256D630
12VL200M8-03	12VLX200M8-03	20	200/3	12.94	25456E557	25256D038	25256D638
12VL200M8-23	12VLX200M8-23	20	230/3	12.94	25456E557	25256D038	25256D638
12VL200M8-43	12VLX200M8-43	20	460/3	12.94	25456E557	25256D037	25256D637
12VL200M8-53	12VLX200M8-53	20	575/3	12.94	25456E557	25256D030	25256D630
12VL250M8-03	12VLX250M8-03	25	200/3	13.5	25456E554	25256D035	25256D635
12VL250M8-23	12VLX250M8-23	25	230/3	13.5	25456E554	25256D035	25256D635
12VL250M8-43	12VLX250M8-43	25	460/3	13.5	25456E554	25256D037	25256D637
12VL250M8-53	12VLX250M8-53	25	575/3	13.5	25456E554	25256D037	25256D637
12VL300M8-23	12VLX300M8-23	30	230/3	14	25456E552	25256D035	25256D635
12VL300M8-43	12VLX300M8-43	30	460/3	14	25456E552	25256D037	25256D637
12VL300M8-53	12VLX300M8-53	30	575/3	14	25456E552	25256D037	25256D637

NOTE: Standard non-overloading impeller diameters and 35' cords shown.

TROUBLESHOOTING

CHECK LIST IF PUMP DOES NOT OPERATE PROPERLY

Checking for Moisture in Motor Use an ohm - meter or a megger and set on highest scale. Readings on the large power cord between any of the conductors red, black or white to the green conductor or to the motor housing should be greater than 1,000,000 ohms (1 megohm). Service work should be done only at an authorized service facility. Note, readings should be taken with line leads disconnected from the control panel.

Resistance of Windings Every motor winding has a fixed resistance. The windings must check close to specification values. Verification of the proper wiring of a dual voltage motor can also be checked by measuring the motor winding resistance.

CONDITION	PROBABLE CAUSE
Red light comes on at control box.	This indicates some water has leaked past the lower seal and has entered the seal chamber and made contact with the electrode probe. Pump must be removed for replacement of lower seal. This preventive repair will save an expensive motor.
Overload trips at control box and alarm buzzer or flashing red light comes on due to high water level in basin.	<ol style="list-style-type: none"> 1. Push in on red reset button to reset overload. If overload trips again after short run, pump has some damage and must be removed from basin for checking. 2. Trouble may be from clogged impeller causing motor to overload or could be from failed motor. 3. Trouble may be from faulty component in control box. Always check control box before removing pump.
Yellow run light stays on continuously.	<ol style="list-style-type: none"> 1. Indicates H-0-A switch may be in the hand position. 2. Level control switch may have failed causing pump to continue to operate when water is below lower control. 3. Impeller may be partially clogged causing pump to operate at very reduced capacity. 4. Gate valve or check valve may be clogged causing low pump flow. 5. Pump may be air locked.
Circuit breaker trips.	<ol style="list-style-type: none"> 1. Reset breaker by pushing completely down on handle then back to ON position. If breaker trips again in a few seconds it indicates excessive load probably caused by a short in the motor or control box. Check out instructions given with control box before pulling pump. 2. If this condition happens after an electrical storm, motor or control box may be damaged by lightning. 3. Resistance reading of the motor with lead wires disconnected from the control box can determine if trouble is in motor or control box.
Pump is noisy and pump rate is low.	<ol style="list-style-type: none"> 1. Impeller may be partially clogged with some foreign objects causing noise and overload on the motor. 2. Impeller may be rubbing on wear ring due to bent shaft or misalignment. 3. Pump may be operating too close to shut-off. Check head.
Grease and solids have accumulated around pump and will not pump out of basin.	<ol style="list-style-type: none"> 1. Lower control switch may be set too high. 2. Run pump on hand operation for several minutes with small amount of water running into basin to clean out solids and grease. This allows pump to break suction and surge which will break up the solids. If level switch is set properly this condition generally will not occur. 3. Trash and grease may have accumulated around floats causing pump to operate erratically.

WARRANTY

STANDARD LIMITED WARRANTY

Pentair Myers® warrants its products against defects in material and workmanship for a period of 12 months from the date of shipment from Pentair Myers or 18 months from the manufacturing date, whichever occurs first – provided that such products are used in compliance with the requirements of the Pentair Myers catalog and technical manuals for use in pumping raw sewage, municipal wastewater or similar, abrasive-free, noncorrosive liquids.

During the warranty period and subject to the conditions set forth, Pentair Myers, at its discretion, will repair or replace to the original user, the parts that prove defective in materials and workmanship. Pentair Myers reserves the right to change or improve its products or any portions thereof without being obligated to provide such a change or improvement for prior sold and/or shipped units.

Start-up reports and electrical schematics may be required to support warranty claims. Submit at the time of start-up through the Pentair Myers website: <http://forms.pentairliterature.com/startupform/startupform.asp?type=m>. Warranty is effective only if Pentair Myers authorized control panels are used. All seal fail and heat sensing devices must be hooked up, functional and monitored or this warranty will be void. Pentair Myers will cover only the lower seal and labor thereof for all dual seal pumps. Under no circumstance will Pentair Myers be responsible for the cost of field labor, travel expenses, rented equipment, removal/reinstallation costs or freight expenses to and from the factory or an authorized Pentair Myers service facility.

This limited warranty will not apply: (a) to defects or malfunctions resulting from failure to properly install, operate or maintain the unit in accordance with the printed instructions provided; (b) to failures resulting from abuse, accident or negligence; (c) to normal maintenance services and parts used in connection with such service; (d) to units that are not installed in accordance with applicable local codes, ordinances and good trade practices; (e) if the unit is moved from its original installation location; (f) if unit is used for purposes other than for what it is designed and manufactured; (g) to any unit that has been repaired or altered by anyone other than Pentair Myers or an authorized Pentair Myers service provider; (h) to any unit that has been repaired using non factory specified/OEM parts.

Warranty Exclusions: PENTAIR MYERS MAKES NO EXPRESS OR IMPLIED WARRANTIES THAT EXTEND BEYOND THE DESCRIPTION ON THE FACE HEREOF. PENTAIR MYERS SPECIFICALLY DISCLAIMS THE IMPLIED WARRANTIES OF MERCHANTABILITY AND FITNESS FOR ANY PARTICULAR PURPOSE.

Liability Limitation: IN NO EVENT SHALL PENTAIR MYERS BE LIABLE OR RESPONSIBLE FOR CONSEQUENTIAL, INCIDENTAL OR SPECIAL DAMAGES RESULTING FROM OR RELATED IN ANY MANNER TO ANY PENTAIR MYERS PRODUCT OR PARTS THEREOF. PERSONAL INJURY AND/OR PROPERTY DAMAGE MAY RESULT FROM IMPROPER INSTALLATION. PENTAIR MYERS DISCLAIMS ALL LIABILITY, INCLUDING LIABILITY UNDER THIS WARRANTY, FOR IMPROPER INSTALLATION. PENTAIR MYERS RECOMMENDS INSTALLATION BY PROFESSIONALS.

Some states do not permit some or all of the above warranty limitations or the exclusion or limitation of incidental or consequential damages and therefore such limitations may not apply to you. No warranties or representations at any time made by any representatives of Pentair Myers shall vary or expand the provision hereof.



1101 Myers Parkway
Ashland, Ohio 44805
USA
Ph: 855-274-8947

490 Pinebush Road
Unit 4
Cambridge, Ontario
N1t 0A5
Canada
Ph: 800.363.7867

pentair.com

All indicated Pentair trademarks and logos are property of Pentair. Third party registered and unregistered trademarks and logos are the property of their respective owners. Because we are continuously improving our products and services, Pentair reserves the right to change specifications without prior notice. Pentair is an equal opportunity employer.