

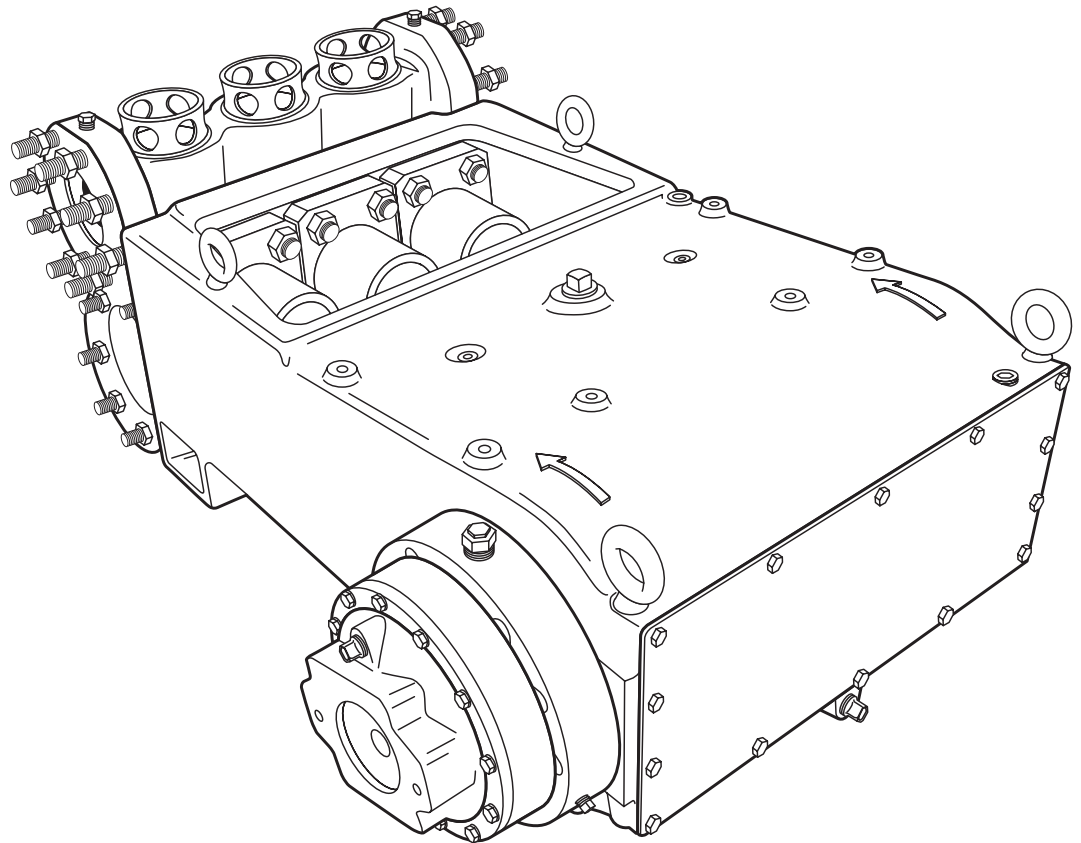

MYERS® APLEX SERIES



MODELS

MA-95L, MA-95M, MA-120L, MA-120L-HD, MA-120M,
SC-170, SC-170L, SC-170H, AND SC-170DD

TRIPLEX PUMPS

INSTALLATION AND SERVICE MANUAL

NOTE! To the installer: Please make sure you provide this manual to the owner of the equipment or to the responsible party who maintains the system.

Engineering Data

MA-95L	3
MA-95M	4
MA-120L	5
MA-120L-HD	6
MA-120M	7
SC-170L	8
SC-170	9
SC-170H	10
SC-170DD	11

Dimensional Data..... 12-13**Installation, Operation, Lubrication, Maintenance and Storage Instructions 14**

Safety	14
Storage	14
Pump Location and Piping Design.....	14
Suction Piping	14-15
Acceleration Head	15
Discharge Piping	15-16
Bypass Piping	16
Lubrication	16
V-Belt Drive	16, 18
Suggested Piping System for Plunger Pumps	17
Direction of Rotation	18
Automatic (Safety) Shutdowns	18

Crankshaft Assembly..... 18

General.....	18
Tapered Roller Bearings	18-19
Cup Installation	19

Installing Crankshaft 19

Shim Adjustment of Tapered Roller Bearings	19
Installation of Crankshaft Oil Seal.....	19
Lube Oil Pump Assembly	19
Disassembly	19-20

Connecting Rod, Crosshead, Extension Rod, Cross-head Pin and Wiper Box Assembly/Disassembly 20

General.....	20
Installing Wrist Pin Bushings	20
Pinning the Crosshead.....	20-21
Order of Assembly.....	21
Precision Crankpin (Crankthrow) Bearings.....	21
Oil Scoop.....	21

Wiper Box Assembly..... 21

General.....	21
“Poly Pak” Seal	21
Mechanical Oil Seal.....	21-22
Inserting the Plunger	22

Stuffing Box, Packing and Plunger Assemblies 22

General.....	22
Spring Loaded Packing	22
J-Style Stuffing Box & Plunger Assembly (Styles 838 and 858)	22-23
Inserting the Plunger	23
Installing the Gland.....	23
Installing the Stuffing Box.....	23
Connecting the Plunger	23
Packing.....	23-24
Plungers.....	24

Disc Valve Systems and Abrasion Resistant 24

General.....	24
Disc Valve and Abrasion Resistant Valve Construction.....	24
Setting the Valve Seat.....	24
Installing O-Rings, Abrasion Resistant Spring and Cage.....	24
Installing Disc, Spring, Disc Valves and Stem ..	24-25
Valve Spring Options	25
Valve Disc Options	25
Pulling the Valve Seat.....	25
Salvage of Worn Seats.....	25
Other Pump Brands	25

Trouble Location and Remedy..... 26-28**Parts Lists 29-38****Warranty..... 40**

MA-95L ENGINEERING DATA	
Power End	
Model Triplex Pump	MA-95L
Maximum Input HP at Speed	95 at 450 rpm
Rated Continuous Plunger Load	6,259 lbs.
Stroke	4"
Maximum Rated Continuous Speed	450 rpm
Normal Continuous Speed Range	150 to 420 rpm
Minimum Speed	100 rpm
Oil Capacity	18 U.S. Quarts
Viscosity, S.S.U. at 210°F	70 to 84
Power End Oiling System	Splash & Scoop
Power Frame, One Piece	Cast Iron
Crosshead, Full Cylindrical	Cast Iron
Crosshead, Diameter x Length	5-3/4" x 6-3/16"
Crankshaft	Ductile Iron
Crankshaft Diameters: At Drive Extension	3.750/3.749"
At Tapered Roller Bearings	4"
At Crankpin Bearings, Diameter x Length	4" x 3"
Crosshead (Wrist) Pin, Case-Hardened and Ground	AISI 8620
Wrist Pin Bushing, SAE 660, Diameter x Width	4" x 3"
Main Bearings, Tapered Roller	Timken
Center Bearings, Two, Precision	Steel Backed, Babbitt-Lined
Crankpin Bearings, Precision Automotive	Steel Backed, Babbitt-Lined
Extension (Pony) Rod: Diameter	2"
Material	316 S.S.
Connecting Rod, Automotive Type	Ductile Iron
Average Crosshead Speed: At 450 rpm	300 fpm
At 150 rpm	100 fpm
Minimum Life Expectancy, Main Bearings, L ₁₀	60,000+hr
Liquid End	
Plunger Size Range, Diameter	2-3/8" thru 3-1/2"
Maximum Continuous Working Pressure	1,264 psi
Hydrostatic Test: Discharge	1,896 psi
Suction	425 psi
Discharge Connection Size	2-1/2" NPTF
Suction Connection Size	5" NPTF
Maximum Working Pressure Suction Manifold	275 psi
Available Liquid End Materials, ASTM: Nickel Aluminum Bronze	B148-C955
Forged Steel Block	A105
Ductile Iron	A536 80-55-06
Stainless Steel	Various Grades

MA-95L ENGINEERING DATA	
Liquid End (Continued)	
Plunger Type Rokide® Stainless Steel: Chromium Oxide-Coated	316 S.S.
Stuffing Boxes, Field-Removable and Replaceable: Aluminum Bronze	B148-C955
Stainless Steel, Hardened	17-4PH
Carbon Steel	1020
Packing Types Available: Gland-loaded, Nonadjustable	Style 838
Spring-loaded, Cup-Type	Style 120X
Spring-loaded, Braided PTFE Coating & Kevlar®	Style 140/141
Spring-loaded, Garlock	Style 8921K
Seals, Stuffing Boxes, Valve Covers, Cylinder Heads	Buna-N
Studs, Material, ASTM	A193 Grade B7, Cadmium Plated
Available Valve Types: Optional, Hardened and Lapped	17-4PH S.S.
Valve Spring Material	Inconel®
Valve Seat, Liquid Passage Areas	6.26 sq. in.
Average Liquid Velocity, with 3-1/2" Plungers: At 450 Crankshaft rpm	8.45 fps
Average Liquid Velocity, 3-1/2" Plungers at 450 rpm: Suction Manifold	3.60 fps
Discharge Manifold	17.02 fps
General	
Overall Dimensions: Length	50-1/4"
Width	38-1/8"
Height	19-5/8"
Approximate Weights: With Aluminum Bronze Liquid End	1,725 lbs.
With Forged Steel Liquid End	1,860 lbs.

MA-95M ENGINEERING DATA	
Power End	
Model Triplex Pump	MA-95M
Maximum Input HP at Speed	95 at 450 rpm
Rated Continuous Plunger Load	6,259 lbs.
Stroke	4"
Maximum Rated Continuous Speed	450 rpm
Normal Continuous Speed Range	150 to 420 rpm
Minimum Speed	100 rpm
Oil Capacity	18 U.S. Quarts
Viscosity, S.S.U. at 210°F	70 to 84
Power End Oiling System	Splash
Power Frame, One Piece	Cast Iron
Crosshead, Full Cylindrical	Cast Iron
Crosshead, Diameter x Length	5-3/4" x 6-3/16"
Crankshaft	Ductile Iron
Crankshaft Diameters: At Drive Extension	3.750/3.749"
At Tapered Roller Bearings	4"
At Crankpin Bearings, Diameter x Length	4" x 3"
Crosshead (Wrist) Pin, Case-Hardened and Ground	AISI 8620
Wrist Pin Bushing, SAE 660, Diameter x Width	2" x 3"
Main Bearings, Tapered Roller	Timken
Crankpin Bearings, Precision Automotive	Steel Backed, Babbitt-Lined
Extension (Pony) Rod: Diameter	2"
Material	17-4PH S.S.
Connecting Rod, Automotive Type	Ductile Iron
Average Crosshead Speed: At 450 rpm	318 fpm
Minimum Life Expectancy, Main Bearings, L ₁₀	45,000+hr
Liquid End	
Plunger Size Range, Diameter	1-1/2" Thru 2-1/4"
Maximum Continuous Working Pressure	3,250 psi
Hydrostatic Test: Discharge	5,400 psi
Suction	425 psi
Discharge Connection Size	2" ANSI 1500RF
Suction Connection Size	3" ANSI 150RF
Available Liquid End Materials, ASTM: Nickel Aluminum Bronze	B148-C955
Forged Steel Block	A105
Plunger Type Rokide® Stainless Steel: Chromium Oxide-Coated	316 S.S.
Stuffing Boxes, Field-Removable and Replaceable: Aluminum Bronze	B148-C955
Carbon Steel	1020

MA-95M ENGINEERING DATA	
Liquid End (Continued)	
Packing Types Available: Gland-loaded, Nonadjustable Spring-loaded, Cup-Type Spring-loaded, Braided PTFE Coating & Kevlar® Spring-loaded, Garlock	Style 838 Style 120X Style 140/141 Style 8921K
Seals, Stuffing Boxes, Valve Covers, Cylinder Heads	Buna-N
Studs, Material, ASTM	A193 Grade B7, Cadmium Plated
Available Valve Types: Regularly Furnished, Acetal Resin Optional, Hardened and Lapped	Acetol 17-4PH S.S.
Valve Spring Material	Inconel®
Valve Seat, Liquid Passage Areas	2.35 sq. in.
Average Liquid Velocity, with 2-1/4" Plungers: At 450 Crankshaft rpm	8.97 fps
Average Liquid Velocity, 2-1/4" Plungers at 450 rpm: Suction Manifold	4.47 fps
Discharge Manifold	10.09 fps
General	
Overall Dimensions: Length	48-3/4"
Width	42-5/8"
Height	19-5/8"
Approximate Weights: With Aluminum Bronze Liquid End	1,950 lbs.
With Ductile Iron Liquid End	1,875 lbs.
With Forged Steel Liquid End	2,085 lbs.

MA-120L ENGINEERING DATA	
Power End	
Model Triplex Pump	MA-120L
Maximum Input HP at Speed	120 at 450 rpm
Rated Continuous Plunger Load	7,452 lbs.
Stroke	4-1/4"
Maximum Rated Continuous Speed	450 rpm
Normal Continuous Speed Range	150 to 420 rpm
Minimum Speed	100 rpm
Oil Capacity	18 U.S. Quarts
Viscosity, S.S.U. at 210°F	70 to 84
Power End Oiling System	Full Pressure Lubrication
Power Frame, One Piece	Cast Iron
Crosshead, Full Cylindrical	Cast Iron
Crosshead, Diameter x Length	5-3/4" x 6-3/16"
Crankshaft	Ductile Iron
Crankshaft Diameters: At Drive Extension At Tapered Roller Bearings At Crankpin Bearings, Diameter x Length	3.750/3.749" 4" 4" x 3"
Crosshead (Wrist) Pin, Case-Hardened and Ground	AISI 8620
Wrist Pin Bushing, SAE 660, Diameter x Width	4" x 3"
Main Bearings, Tapered Roller	Timken
Crankpin Bearings, Precision Automotive	Steel Backed, Babbitt-Lined
Extension (Pony) Rod: Diameter Material	2" 316 S.S.
Connecting Rod, Automotive Type	Ductile Iron
Average Crosshead Speed: At 450 rpm At 150 rpm	318 fpm 106 fpm
Minimum Life Expectancy, Main Bearings, L ₁₀	60,000+hr
Liquid End	
Plunger Size Range, Diameter	2-3/8" Thru 3-1/2"
Maximum Continuous Working Pressure	1,682 psi
Hydrostatic Test: Discharge Suction	2,523 psi 425 psi
Discharge Connection Size	2-1/2" ANSI 900 LF
Suction Connection Size	5" ANSI 150 FF
Maximum Working Pressure Suction Manifold	275 psi
Available Liquid End Materials, ASTM: Nickel Aluminum Bronze Forged Steel Block Ductile Iron Stainless Steel	B148-C955 A105 A536 80-55-06 Various Grades

MA-120L ENGINEERING DATA	
Liquid End (Continued)	
Plunger Type Rokide® Stainless Steel: Chromium Oxide-Coated	316 S.S.
Stuffing Boxes, Field-Removable and Replaceable: Aluminum Bronze Stainless Steel, Hardened Carbon Steel	B148-C955 17-4PH 1020
Packing Types Available: Gland-loaded, Nonadjustable Spring-loaded, Cup-Type Spring-loaded, Braided PTFE Coating & Kevlar® Spring-loaded, Garlock	Style 838 Style 120X Style 140/141 Style 8921K
Seals, Stuffing Boxes, Valve Covers, Cylinder Heads	Buna-N
Studs, Material, ASTM	A193 Grade B7, Cadmium Plated
Available Valve Types: Standard, Acetal Resin Optional, Hardened and Lapped	Acetol 17-4PH S.S.
Valve Spring Material	Inconel®
Valve Seat, Liquid Passage Areas	6.26 sq. in.
Average Liquid Velocity, with 3-1/2" Plungers: At 450 Crankshaft rpm	8.45 fps
Average Liquid Velocity, 3-1/2" Plungers at 450 rpm: Suction Manifold Discharge Manifold	3.60 fps 17.02 fps
General	
Overall Dimensions: Length Width Height	49" 42-5/8" 19-1/16"
Approximate Weights: With Aluminum Bronze Liquid End With Forged Steel Liquid End	1,725 lbs. 1,860 lbs.

MA-120L-HD ENGINEERING DATA	
Power End	
Model Triplex Pump	MA-120L-HD
Maximum Input HP at Speed	144 at 450 rpm
Rated Continuous Plunger Load	8,937 lbs.
Stroke	4-1/4"
Maximum Rated Continuous Speed	450 rpm
Normal Continuous Speed Range	150 to 420 rpm
Minimum Speed	100 rpm
Oil Capacity	18 U.S. Quarts
Viscosity, S.S.U. at 210°F	70 to 84
Power End Oiling System	Full Pressure Lubrication
Power Frame, One Piece	Cast Iron
Crosshead, Full Cylindrical	Cast Iron
Crosshead, Diameter x Length	5-3/4" x 6-3/16"
Crankshaft	Forged and Nitrided Alloy Steel
Crankshaft Diameters: At Drive Extension At Tapered Roller Bearings At Crankpin Bearings, Diameter x Length	3.750/3.749" 4" 4" x 3"
Crosshead (Wrist) Pin, Case-Hardened and Ground	AISI 8620
Wrist Pin Bushing, SAE 660, Diameter x Width	4" x 3"
Main Bearings, Tapered Roller	Timken
Crankpin Bearings, Precision Automotive	Steel Backed, Babbitt-Lined
Extension (Pony) Rod: Diameter Material	2" 316 S.S.
Connecting Rod, Automotive Type	Ductile Iron
Average Crosshead Speed: At 450 rpm At 150 rpm	318 fpm 106 fpm
Minimum Life Expectancy, Main Bearings, L ₁₀	50,000+hr
Liquid End	
Plunger Size Range, Diameter	2-3/8" Thru 3-1/2"
Maximum Continuous Working Pressure	1,682 psi
Hydrostatic Test: Discharge Suction	2,523 psi 425 psi
Discharge Connection Size	2-1/2" ANSI 900 LF
Suction Connection Size	5" ANSI 150 FF
Maximum Working Pressure Suction Manifold	275 psi
Available Liquid End Materials, ASTM: Nickel Aluminum Bronze Forged Steel Block Ductile Iron Stainless Steel	B148-C955 A105 A536 80-55-06 Various Grades

MA-120L-HD ENGINEERING DATA	
Liquid End (Continued)	
Plunger Type Rokide® Stainless Steel: Chromium Oxide-Coated	316 S.S.
Stuffing Boxes, Field-Removable and Replaceable: Aluminum Bronze Stainless Steel, Hardened Carbon Steel	B148-C955 17-4PH 1020
Packing Types Available: Gland-loaded, Nonadjustable Spring-loaded, Cup-Type Spring-loaded, Braided PTFE Coating & Kevlar® Spring-loaded, Garlock	Style 838 Style 120X Style 140/141 Style 8921K
Seals, Stuffing Boxes, Valve Covers, Cylinder Heads	Buna-N
Studs, Material, ASTM	A193 Grade B7, Cadmium Plated
Available Valve Types: Standard, Acetal Resin Optional, Hardened and Lapped	Acetol 17-4PH S.S.
Valve Spring Material	Inconel®
Valve Seat, Liquid Passage Areas	6.26 sq. in.
Average Liquid Velocity, with 3-1/2" Plungers: At 450 Crankshaft rpm	8.45 fps
Average Liquid Velocity, 3-1/2" Plungers at 450 rpm: Suction Manifold Discharge Manifold	3.60 fps 17.02 fps
General	
Overall Dimensions: Length Width Height	49" 42-5/8" 19-1/16"
Approximate Weights: With Aluminum Bronze Liquid End With Forged Steel Liquid End	1,725 lbs. 1,860 lbs.

MA-120M ENGINEERING DATA	
Power End	
Model Triplex Pump	MA-120M
Maximum Input HP at Speed	120 at 450 rpm
Rated Continuous Plunger Load	7,452 lbs.
Stroke	4-1/4"
Maximum Rated Continuous Speed	450 rpm
Normal Continuous Speed Range	150 to 420 rpm
Minimum Speed	100 rpm
Oil Capacity	18 U.S. Quarts
Viscosity, S.S.U. at 210°F	70 to 84
Power End Oiling System	Pressure Lubrication
Power Frame, One Piece	Cast Iron
Crosshead, Full Cylindrical	Cast Iron
Crosshead, Diameter x Length	5-3/4" x 6-3/16"
Crankshaft	Ductile Iron
Crankshaft Diameters:	
At Drive Extension	3.750/3.749"
At Tapered Roller Bearings	4"
At Crankpin Bearings, Diameter x Length	4" x 3"
Crosshead (Wrist) Pin, Case-Hardened and Ground	AISI 8620
Wrist Pin Bushing, SAE 660, Diameter x Width	2" x 3"
Main Bearings, Tapered Roller	Timken
Crankpin Bearings, Precision Automotive	Steel Backed, Babbitt-Lined
Extension (Pony) Rod:	
Diameter	2"
Material	17-4PH S.S.
Connecting Rod, Automotive Type	Ductile Iron
Average Crosshead Speed:	
At 450 rpm	318 fpm
Minimum Life Expectancy, Main Bearings, L ₁₀	45,000+hr
Liquid End	
Plunger Size Range, Diameter	1-1/2" Thru 2-1/4"
Maximum Continuous Working Pressure	3,691 psi
Hydrostatic Test:	
Discharge	5,400 psi
Suction	425 psi
Discharge Connection Size	2" NPTF
Suction Connection Size	3" NPTF
Available Liquid End Materials, ASTM:	
Nickel Aluminum Bronze	B148-C955
Forged Steel Block	A105
Plunger Type Rokide® Stainless Steel:	
Chromium Oxide-Coated	316 S.S.

MA-120M ENGINEERING DATA	
Liquid End (Continued)	
Stuffing Boxes, Field-Removable and Replaceable:	
Aluminum Bronze	B148-C955
Carbon Steel	1020
Packing Types Available:	
Gland-loaded, Nonadjustable	Style 838
Spring-loaded, Cup-Type	Style 120X
Spring-loaded, Braided PTFE Coating & Kevlar®	Style 140/141
Spring-loaded, Garlock	Style 8921K
Seals, Stuffing Boxes, Valve Covers, Cylinder Heads	Buna-N
Studs, Material, ASTM	A193 Grade B7, Cadmium Plated
Available Valve Types:	
Regularly Furnished, Acetal Resin	Acetol
Optional, Hardened and Lapped	17-4PH S.S.
Valve Spring Material	Inconel®
Valve Seat, Liquid Passage Areas	2.35 sq. in.
Average Liquid Velocity, with 2-1/4" Plungers:	
At 450 Crankshaft rpm	8.97 fps
Average Liquid Velocity, 2-1/4" Plungers at 450 rpm:	
Suction Manifold	4.47 fps
Discharge Manifold	10.09 fps
General	
Overall Dimensions:	
Length	48-3/4"
Width	42-5/8"
Height	19-5/8"
Approximate Weights:	
With Aluminum Bronze Liquid End	1,950 lbs.
With Ductile Iron Liquid End	1,875 lbs.
With Forged Steel Liquid End	2,085 lbs.

SC-170L ENGINEERING DATA	
Power End	
Model Triplex Pump	SC-170L
Maximum Input HP at Speed	230 at 450 rpm
Rated Continuous Plunger Load	14,280 lbs.
Stroke	4-1/4"
Maximum Rated Continuous Speed	450 rpm
Normal Continuous Speed Range	150 to 420 rpm
Minimum Speed	100 rpm
Oil Capacity	18 U.S. Quarts
Viscosity, S.S.U. at 210°F	70 to 84
Power End Oiling System	Pressure Lubrication
Power Frame, One Piece	Cast Iron
Crosshead, Full Cylindrical	Cast Iron
Crosshead, Diameter x Length	5-3/4" x 6-3/16"
Crankshaft	Forged Steel and Nitrided
Crankshaft Diameters: At Drive Extension At Tapered Roller Bearings At Crankpin Bearings, Diameter x Length	3.750/3.749" 4" 4" x 3"
Crosshead (Wrist) Pin, Case-Hardened and Ground	AISI 8620
Wrist Pin Bushing, SAE 660, Diameter x Width	2" x 3"
Main Bearings, Tapered Roller	Timken
Crankpin Bearings, Precision Automotive	Steel Backed, Babbitt-Lined
Extension (Pony) Rod: Diameter Material	2" 17-4PH S.S.
Connecting Rod, Automotive Type	Ductile Iron
Average Crosshead Speed: At 450 rpm	318 fpm
Minimum Life Expectancy, Main Bearings, L ₁₀	45,000+hr
Liquid End	
Plunger Size Range, Diameter	3" Thru 4"
Maximum Continuous Working Pressure	2,020 psi
Hydrostatic Test: Discharge Suction	3,250 psi 425 psi
Discharge Connection Size	2-1/2" ANSI 900LF
Suction Connection Size	5" ANSI 150LF
Available Liquid End Materials, ASTM: Nickel Aluminum Bronze Forged Steel Block Ductile Iron	B148-C955 A105 A536 80-55-06
Plunger Type Rokide® Stainless Steel: Rokide® TX	316 S.S. 416 S.S.

SC-170L ENGINEERING DATA	
Liquid End (Continued)	
Stuffing Boxes, Field-Removable and Replaceable: Aluminum Bronze Carbon Steel	B148-C955 1020
Piston Liner: Chrome Oxide Coated High Chrome Iron	4121 4121
Packing Types Available: Gland-loaded, Nonadjustable Spring-loaded, Cup-Type Spring-loaded, Braided PTFE Coating & Kevlar® Spring-loaded, Garlock	Style 838 Style 120X Style 140/141 Style 8921K
Piston Cups Available: Urethane Nitrile HSN and Kevlar®	
Seals, Stuffing Boxes, Valve Covers, Cylinder Heads	Buna-N
Studs, Material, ASTM	A193 Grade B7, Cadmium Plated
Available Valve Types: Regularly Furnished Optional, Hardened and Lapped	Abrasion Resistant 17-4PH S.S.
Valve Spring Material	Inconel®
Valve Seat, Liquid Passage Areas	3.3 sq. in.
Average Liquid Velocity, with 4" Plungers: At 450 Crankshaft rpm	20.2 fps
Average Liquid Velocity, 4" Plungers at 450 rpm: Suction Manifold Discharge Manifold	4.9 fps 23.5 fps
General	
Overall Dimensions: Length Width Height	50-1/4" 42-5/8" 19-5/8"
Approximate Weights: With Aluminum Bronze Liquid End With Ductile Iron Liquid End With Forged Steel Liquid End	2,050 lbs. 1,975 lbs. 2,185 lbs.

SC-170 ENGINEERING DATA	
Power End	
Model Triplex Pump	SC-170
Maximum Input HP at Speed	230 at 450 rpm
Rated Continuous Plunger Load	14,280 lbs.
Stroke	4-1/4"
Maximum Rated Continuous Speed	450 rpm
Normal Continuous Speed Range	150 to 420 rpm
Minimum Speed	100 rpm
Oil Capacity	18 U.S. Quarts
Viscosity, S.S.U. at 210°F	70 to 84
Power End Oiling System	Pressure Lubrication
Power Frame, One Piece	Cast Iron
Crosshead, Full Cylindrical	Cast Iron
Crosshead, Diameter x Length	5-3/4" x 6-3/16"
Crankshaft	Nitrided Forged Steel
Crankshaft Diameters: At Drive Extension At Tapered Roller Bearings At Crankpin Bearings, Diameter x Length	3.750/3.749" 4" 4" x 3"
Crosshead (Wrist) Pin, Case-Hardened and Ground	AISI 8620
Wrist Pin Bushing, SAE 660, Diameter x Width	2" x 3"
Main Bearings, Tapered Roller	Timken
Crankpin Bearings, Precision Automotive	Steel Backed, Babbitt-Lined
Extension (Pony) Rod: Diameter Material	2" 17-4PH S.S.
Connecting Rod, Automotive Type	Ductile Iron
Average Crosshead Speed: At 450 rpm At 150 rpm	300 fpm 100 fpm
Minimum Life Expectancy, Main Bearings, L ₁₀	60,000+hr
Liquid End	
Plunger Size Range, Diameter	2-1/2" Thru 3-1/8"
Maximum Continuous Working Pressure	3,000 psi
Hydrostatic Test: Discharge Suction	4,500 psi 425 psi
Discharge Connection Size	2-1/2" NPTF
Suction Connection Size	4" NPTF
Maximum Working Pressure Suction Manifold	275 psi
Available Liquid End Materials, ASTM: Forged Steel Block	A105

SC-170 ENGINEERING DATA	
Liquid End (Continued)	
Plunger Type Rokide® Stainless Steel: Chromium Oxide-Coated	410 S.S.
Stuffing Boxes, Field-Removable and Replaceable: Carbon Steel	1020
Packing Types Available: Gland-loaded, Nonadjustable Spring-loaded, Cup-Type Spring-loaded, Braided PTFE Coating & Kevlar® Spring-loaded, Garlock	Style 838 Style 120X Style 140/141 Style 8921K
Seals, Stuffing Boxes, Valve Covers, Cylinder Heads	Buna-N
Studs, Material, ASTM	A193 Grade B7, Cadmium Plated
Available Valve Types: Optional, Hardened and Lapped	17-4PH S.S.
Valve Spring Material	Inconel®
Valve Seat, Liquid Passage Areas	3.925 sq. in.
Average Liquid Velocity, with 3-1/8" Plungers: At 450 Crankshaft rpm At 150 Crankshaft rpm	9.71 fps 3.23 fps
Average Liquid Velocity, 3-1/8" Plungers at 450 rpm: Suction Manifold Discharge Manifold	4.54 fps 10.24 fps
General	
Overall Dimensions: Length Width Height	49" 36" 18-1/4"
Approximate Weights: With Forged Steel Liquid End	1,850 lbs.

SC-170H ENGINEERING DATA	
Power End	
Model Triplex Pump	SC-170H
Maximum Input HP at Speed	230 at 450 rpm
Rated Continuous Plunger Load	14,280 lbs.
Stroke	4-1/4"
Maximum Rated Continuous Speed	450 rpm
Normal Continuous Speed Range	150 to 400 rpm
Minimum Speed	100 rpm
Oil Capacity	18 U.S. Quarts
Viscosity, S.S.U.at 210°F	70 to 84
Power End Oiling System	Pressure Lubrication
Power Frame, One Piece	Cast Iron
Crosshead, Full Cylindrical	Cast Iron
Crosshead, Diameter x Length	5-3/4" x 6-3/16"
Crankshaft	Nitrided Forged Steel
Crankshaft Diameters: At Drive Extension At Tapered Roller Bearings At Crankpin Bearings, Diameter x Length	3.750/3.749" 4" 4" x 3"
Crosshead (Wrist) Pin, Case-Hardened and Ground	AISI 8620
Wrist Pin Bushing, SAE 660, Diameter x Width	2" x 3"
Main Bearings, Tapered Roller	Timken
Crankpin Bearings, Precision Automotive	Steel Backed, Babbitt-Lined
Extension (Pony) Rod: Diameter Material	2" 17-4PH S.S.
Connecting Rod, Automotive Type	Ductile Iron
Average Crosshead Speed: At 450 rpm At 150 rpm	300 fpm 100 fpm
Minimum Life Expectancy, Main Bearings, L ₁₀	45,000+hr
Liquid End	
Plunger Size Range, Diameter	1-3/4" Thru 2-3/8"
Maximum Continuous Working Pressure	5,600 psi
Hydrostatic Test: Discharge Suction	9,640 psi 425 psi
Discharge Connection Size	2" NPTF
Suction Connection Size	3" NPTF
Maximum Working Pressure Suction Manifold	275 psi
Available Liquid End Materials, ASTM: Forged Steel Block	4140

SC-170H ENGINEERING DATA	
Liquid End (Continued)	
Plunger Type Rokide® Stainless Steel: Chromium Oxide-Coated	316 S.S.
Stuffing Boxes, Field-Removable and Replaceable: Carbon Steel	1020
Packing Types Available: Spring-loaded, Cup-Type Spring-loaded, Braided Kevlar®	Style 120X Style 140
Seals, Stuffing Boxes, Valve Covers, Cylinder Heads	Buna-N
Studs, Material, ASTM	A193 Grade B7, Cadmium Plated
Available Valve Types: Hardened and Lapped Disc. Optional, Dual Stem Guided Optional, Abrasion Resistant	17-4PH S.S. 17-4PH S.S. 17-4PH S.S.
Valve Spring Material	Inconel®
Average Liquid Velocity, with 1-5/8" Plungers: At 450 Crankshaft rpm	8.0 fps
Average Liquid Velocity, 1-5/8" Plungers at 450 rpm: Suction Manifold Discharge Manifold	3.4 fps 7.6 fps
General	
Overall Dimensions: Length Width Height	49" 36" 18-1/4"
Approximate Weights: With Forged Steel Liquid End	2,025 lbs.

SC-170DD ENGINEERING DATA	
Power End	
Model Triplex Pump	SC-170DD
Maximum Input HP at Speed	230 at 450 rpm
Rated Continuous Plunger Load	14,280 lbs.
Stroke	4-1/4"
Maximum Rated Continuous Speed	450 rpm
Normal Continuous Speed Range	150 to 420 rpm
Minimum Speed	100 rpm
Oil Capacity	18 U.S. Quarts
Viscosity, S.S.U. at 210°F	70 to 84
Power End Oiling System	Pressure Lubrication
Power Frame, One Piece	Cast Iron
Crosshead, Full Cylindrical	Cast Iron
Crosshead, Diameter x Length	5-3/4" x 6-3/16"
Crankshaft	Forged Steel and Nitrided
Crankshaft Diameters: At Drive Extension At Tapered Roller Bearings At Crankpin Bearings, Diameter x Length	3.750/3.749" 4" 4" x 3"
Crosshead (Wrist) Pin, Case-Hardened and Ground	AISI 8620
Wrist Pin Bushing, SAE 660, Diameter x Width	2" x 3"
Main Bearings, Tapered Roller	Timken
Crankpin Bearings, Precision Automotive	Steel Backed, Babbitt-Lined
Extension (Pony) Rod: Diameter Material	2" 17-4PH S.S.
Connecting Rod, Automotive Type	Ductile Iron
Average Crosshead Speed: At 450 rpm	318 fpm
Minimum Life Expectancy, Main Bearings, L ₁₀	45,000+hr
Liquid End	
Plunger Size Range, Diameter	4" Thru 4-1/2"
Maximum Continuous Working Pressure	2,020 psi
Hydrostatic Test: Discharge Suction	3,250 psi 425 psi
Discharge Connection Size	3" ANSI 600FF
Suction Connection Size	6" ANSI 150FF
Available Liquid End Materials, ASTM: Ductile Iron	A536 80-55-06
Piston Liner: Chromed Steel High Chrome Iron	4140 4140

SC-170DD ENGINEERING DATA	
Liquid End (Continued)	
Piston Cups Available: Urethane Nitrile HSN and Kevlar®	
Seals, Stuffing Boxes, Valve Covers, Cylinder Heads	PTFE Coating
Studs, Material, ASTM	A193 Grade B7, Cadmium Plated
Valve Type: Regularly Furnished	Abrasion Resistant
Valve Spring Material	Inconel®
Valve Seat, Liquid Passage Areas	5.15 sq. in.
Average Liquid Velocity, 4" Plungers at 450 rpm: At 450 Crankshaft rpm	12.9 fps
Suction Manifold	3.4 fps
Discharge Manifold	16.3 fps
General	
Overall Dimensions: Length Width Height	53" 42-5/8" 29-1/4"
Approximate Weights: With Ductile Iron Liquid End	2,415 lbs.

CROSS-SECTION

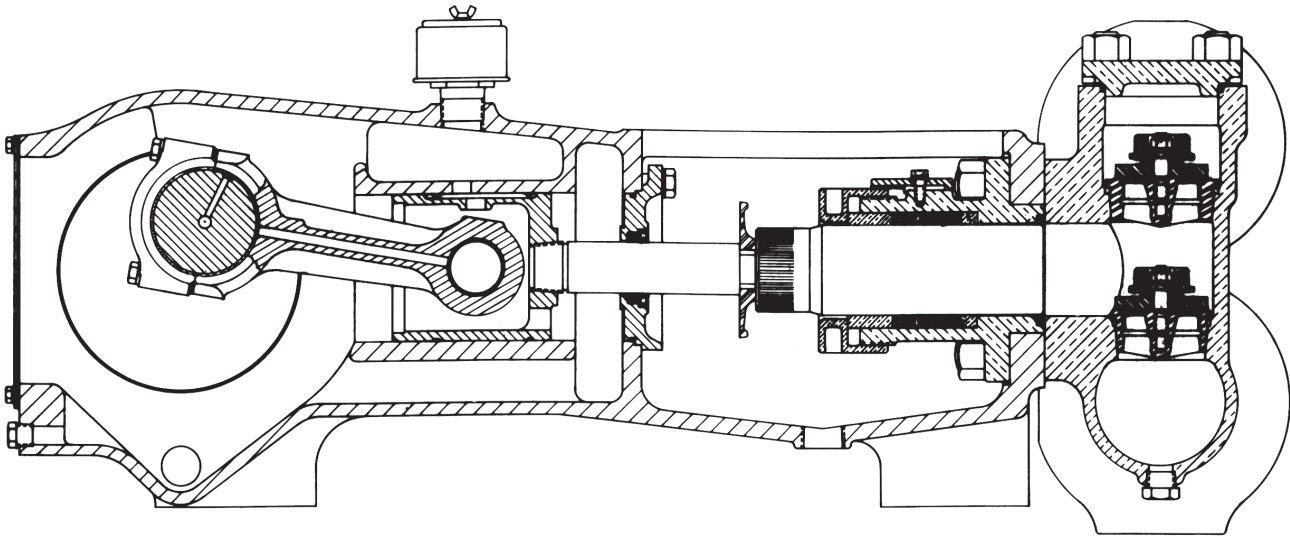

DIMENSIONAL DATA TABLE

Ref. No.	MA-95L	MA-95M	MA-120L	MA-120L-HD	MA-120M	SC-170	SC-170L	SC-170H	SC-170DD
A1	-	8-7/8	8-7/8	8-7/8	8-7/8	-	-	8-7/8	-
A2	36	42-5/8	42-5/8	42-5/8	42-5/8	36	36	42-5/8	46-3/4
A3	21-1/2	21-1/2	21-1/2	21-1/2	21-1/2	21-1/2	21-1/2	21-1/2	22-5/16
A4	23-3/8	23-3/8	23-3/8	23-3/8	23-3/8	-	23-3/8	-	24
A5	11-11/16	11-11/16	11-11/16	11-11/16	11-11/16	-	11-11/16	-	-
B1	49	48-1/2	49	49	48-1/2	-	49	-	53
B2	38-1/4	37-1/2	38-1/4	38-1/4	37-1/2	-	38-1/4	-	38-7/8
B3	19-1/16	17-15/16	19-1/16	19-1/16	17-15/16	-	19-1/16	-	-
B4	9-1/4	9-1/4	9-1/4	9-1/4	9-1/4	-	9-1/4	-	-
B5	10-1/8	8-1/4	10-1/8	10-1/8	8-1/4	-	10-1/8	-	16-1/2
B6	4-1/8	5-1/4	4-1/8	4-1/8	5-1/4	-	4-1/8	-	5-3/4
B7	25-1/8	25-1/8	25-1/8	25-1/8	25-1/8	-	25-1/8	-	25-1/4
(B) Discharge Connections	2-1/2" ANSI 900 LF	2" 1500	2-1/2" ANSI 900 LF	2-1/2" ANSI 900 LF	2" 1500	-	2-1/2" ANSI 900 LF	-	3" 600# FF
(B) Suction Connections	5" ANSI 150 FF	3" 150	5" ANSI 150 FF	5" ANSI 150 FF	3" 150	-	5" ANSI 150 FF	-	6" 150# FF
C1	49-13/16	48-7/16	49-13/16	49-13/16	48-7/16	48-7/8	49-13/16	-	-
C2	38-1/4	37-1/2	38-1/4	38-1/4	37-1/2	38	38-1/4	37-1/2	-
C3	-	18-7/16	-	-	18-7/16	-	-	-	-
C4	-	9-1/4	-	-	9-1/4	9-1/4	-	9-1/4	-
C5	10-1/2	8-1/2	10-1/2	10-1/2	8-1/2	9-3/8	10-1/2	8-7/16	-
C6	3-1/4	5	3-1/4	3-1/4	5	4-1/4	3-1/4	5-1/16	-
C7	33-1/4	33	33-1/4	33-1/4	33	-	33-1/4	-	-
C8	31-5/8	30	31-5/8	31-5/8	30	-	31-5/8	-	-
(C) Discharge Connections	2-1/2" ANSI 900 RF	2" ANSI 1500 RF	2-1/2" ANSI 900 RF	2-1/2" ANSI 900 RF	2" ANSI 1500 RF	2-1/2" NPTF	2-1/2" ANSI 900 RF	2" API 5000	-
(C) Suction Connections	5" ANSI 150 RF	3" ANSI 150 RF	5" ANSI 150 RF	5" ANSI 150 RF	3" ANSI 150 RF	4" NPTF	5" ANSI 150 RF	3" ANSI 300RTJ	-

DIMENSIONAL DRAWINGS

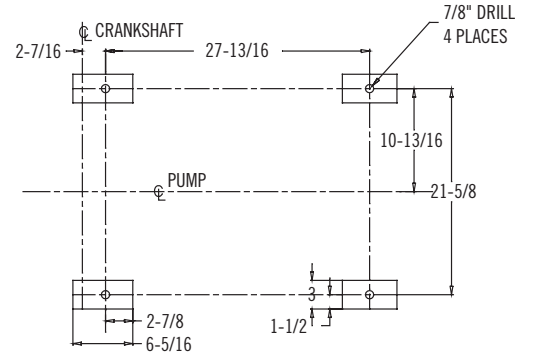
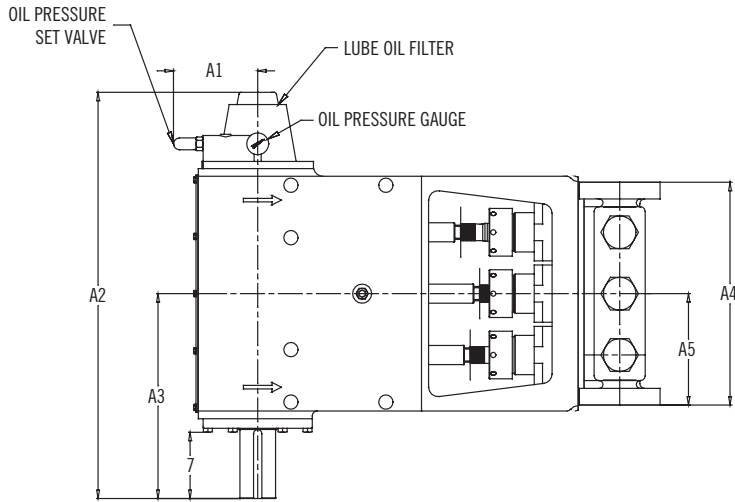

Cast Fluid End

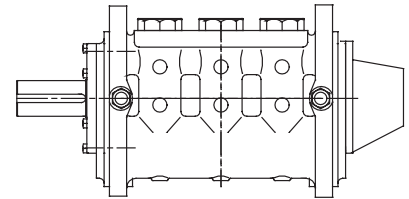
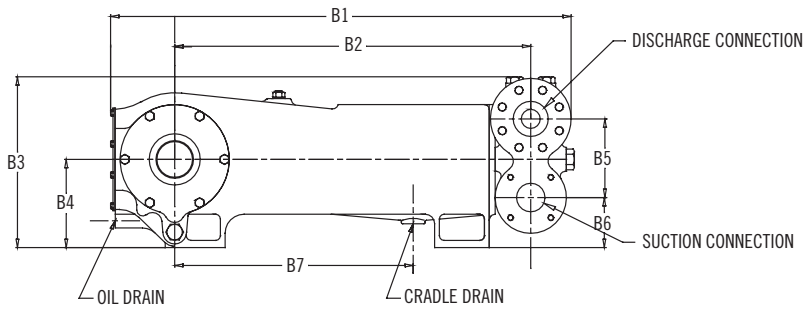

Block Fluid End

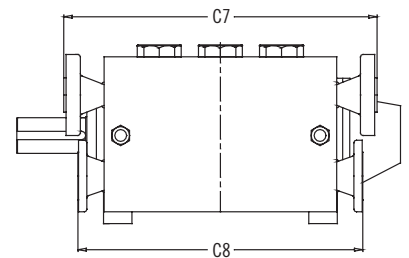
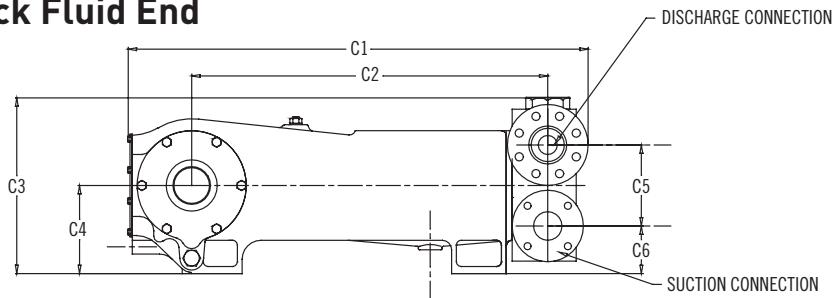

INSTALLATION, OPERATION, LUBRICATION, MAINTENANCE AND STORAGE INSTRUCTIONS

SAFETY

Electrical power or engine must be shut off completely before attempting service on the pump or its drive. Air surrounding the unit to be free of toxic, flammable, or explosive gases.

Tools needed should be planned for in advance (see valve seat pulling instructions), and should be clean and of adequate size. A torque-wrench will be required to tighten connecting rod cap screws.

A properly sized and set relief valve installed in the pump discharge system (ahead of any block valves) is necessary to protect personnel and to avoid dangerous overpressure. The relief valve set pressure should be not more than 25% above the design operating pressure and should discharge to tank or to the atmosphere (toward the ground), and must not be directed back to the pump suction system.

WARNING: Improper use of this equipment could result in loss of life.

CALIFORNIA PROPOSITION 65 WARNING:

WARNING: This product and related accessories contain chemicals known to the State of California to cause cancer, birth defects or other reproductive harm.

STORAGE

Pumps are shipped dry from the factory. If a pump has been in storage in a humid environment for more than 6 months the crankcase cover should be removed and carefully examined for rust or water collected in the power end. Flush out any evidence of rust or damage that exists, using a light clean oil.

Pumps to be placed in extended storage should be cleaned, repaired as needed, and completely filled to the top with clean oil to prevent rusting. Rotate pump monthly 4-1/2 revolutions. Plug all openings to prevent air entry and oil leakage.

Fluid ends must be completely drained of water and suction and discharge ports blanked off. Store pump in a clean, dry location.

PUMP LOCATION AND PIPING DESIGN

Locate pump and driver in a clean, well drained, ventilated, and brightly illuminated area, with adequate

working spaces around the pump to provide ample access to fluid end, power end, and associated drive elements. Do not expect good maintenance to result if the pump is positioned on muddy terrain, or in a dirty, cramped, dimly lighted area!

The supply tank(s) should be large to allow dissolved air and other gases to escape from the liquid and allow suspended solids to settle out before entering pump. A system employing dams and settling chambers is desirable.

CAUTION: All pumps should be installed level. For mobile applications the maximum angle of intermittent operation pumps (SC pumps) should be no more than 5 degrees in any one direction.

Pumps are not designed to withstand piping weight, vibration, and the effects of thermal piping expansion/contraction. Piping loads may be considerable and the weight of all valving, dampeners, filters, and associated forces, moments, and couples must be completely isolated. Use flexible hoses and rigid piping supports to isolate the pump and its driver from these effects.

SUCTION PIPING

No part of the piping system deserves more careful planning than the suction piping system. Suction piping must be short, direct, and oversize. Use one pipe size larger than the pump suction connection. The shorter it is, the better! 1 to 3 feet per second suction velocity is acceptable.

Reference the following table to size a direct suction line from a tank to a pump.

Suction Piping			
3" - 4"	4" - 5"	5" - 6"	6" - 8"
MA-95M	SC-170	MA-95L	SC-170DD
MA-120M		MA-120L	
SC-170H		MA-120L-HD	
		SC-170L	

Use no elbows, tees, or restricted port valves in this line. Do not install orifice plates or positive displacement type fluid meters in the suction line which act as flow restrictors. Avoid the use of suction filters, if possible. Consider filtering the liquid as it enters the supply tank rather than as it leaves it. The use of an eccentric reducer with the flat side up located at the pump suction connection is recommended. The suction line should slightly rise from tank to pump and loops in which air may collect must be avoided.

The absolute pressure in a suction line may be less than atmospheric pressure and air may be "sucked" into the line unless all flanges and connections are airtight and watertight. If you can see water leaking out of a suction line when the pump is still, that may mean air is being sucked in when the pump is running.

Suction piping should be buried beneath the frost line, or insulated to avoid freezing in the winter. If the suction line has a block valve at the supply tank, a suitable relief valve is suggested to relieve the suction piping from any possible dangerous overpressure from the discharge piping system.

Suction piping is often large, heavy (especially when filled with liquid), and tends to vibrate. Proper solid supports are recommended. A suction hose located near the pump will isolate these effects, protecting the pump from the forces and moments that piping weight creates.

New suction piping systems should be flushed free of pipe scale, welding slag, and dirt before starting the pump. Hydrostatic testing to detect air leaks is advisable. Proper choice of suction hose construction is essential to avoid collapse of the hose liner.

Install a dry type compound gauge in the suction line near the pumps which should fluctuate evenly. If violently pulsating, this gauge indicates that the pump is not fully primed, or that one or more valves are inoperative.

ACCELERATION HEAD

A characteristic of all reciprocating pumps is the imperative need to consider the effects of acceleration head which is a system-related phenomenon. Acceleration head may be considered to be the loss of available hydraulic head (energy) in the piping system occurring because the demand by the pump cylinders for liquid is not smooth and even. Because the pump's demand for liquid is cyclical, the velocity of the liquid in the entire suction system is not truly constant but varies in response to the combined demand of the reciprocating plungers. Thus, liquid in the suction system is compelled to be accelerated and decelerated several times during each crankshaft revolution, depending on the number of plungers. Called "acceleration" head, this loss of available hydraulic head is proportional to:

- (a) The speed (RPM) of the crankshaft
- (b) The average liquid velocity in the piping
- (c) The length of the suction piping
- (d) The number of pumping chambers (triplex, etc.)
- (e) The compressibility of the liquid

Thus, for a given pump, acceleration head effects may be reduced by the use of the shortest possible suction line, sized to reduce liquid velocity to a very low speed. This is often more economical than the use of charge pumps or expensive suction stabilizers.

NOTE: Charge pumps should be sized to 150% of rated pump volume. Charge pumps need to be centrifugals, not a positive displacement pump.

A charging pump is usually not a good substitute for a short, direct, oversize suction line, nor is it a substitute for the computation of available NPSH, acceleration head, friction head, vapor pressure and submergence effects duly considered. Required NPSHR of Myers Apex Series pumps depends on speed, choice of plunger size and valve spring type. Consult Myers Apex Series Engineering for help with your particular application. A full discussion of suction system losses is given in the Standards of the Hydraulic Institute, 14th Edition.

A common design mistake is the connecting of two (or more) reciprocating pumps to a common suction header. This is a profoundly complicated suction system, largely not amenable to mathematical analysis, and is frequently the cause of severe pump pounding, vibration and early valve failures. Each pump should be fed by its own separate, individual piping system, free from the effects of other pump cyclical demands for liquid.

DISCHARGE PIPING

A properly designed discharge piping system usually prevents the need of a pulsation dampener. The most common mistakes made in the design of the discharge piping system are:

1. Pumping directly into a tee or header. A "standing" wave (either audible or subaudible) then often occurs. If flow must enter a header, use a 45° branch lateral (or equivalent) to avoid a reflecting surface from which sound can reflect.
2. Pumping into short radius 90° elbows. Instead, use two 45° elbows spaced 10 or more pipe diameters apart.
3. Pumping into a right angle choke valve.
4. Pumping into too small piping line size. Piping should be sized to keep fluid velocity below 15 feet per second, max.
5. Pumping through an orifice plate, small venturi, or reduced port "regular opening" valve.
6. Pumping through a quick closing valve, which can cause hydraulic shock (water-hammer).

A good discharge piping system includes:

1. A properly sized, correctly set relief valve. Discharge from relief valve returned to tank (not to pump suction).
2. A full opening discharge gate or ball valve. Avoid restricting plug valves, globe valves and angle valves.
3. A pressure gauge with gauge dampener or snubber. Consider a liquid filled gauge. (Scale range to be double the normal pump operating pressure.)

Locate the relief valve and pressure gauge ahead of any block valve and so that the pressure in the pump is always reflected at the relief valve. The relieving capacity of the relief valve must exceed the capacity of the pump to avoid excessive pressure while relieving.

Use a full size relief line.

To minimize vibration (whether hydraulic or mechanical), discharge lines should be kept short, direct, well supported and solidly anchored. Avoid “dead” ends and abrupt direction changes.

BYPASS PIPING

Some designers ignore this important aspect of proper design of pump piping systems.

A reciprocating pump, especially after maintenance of the valves or plungers, starts with one or more fluid chambers full of air. Pumps operating on propane, butane, or other volatile liquids start with vapor in the fluid chamber(s).

Positive displacement pumps do not automatically purge themselves of air and gas after shutdown. For example, a quintuplex plunger pump will, after servicing, expel the air in four of the five pump chambers. Thus, the pressure from four of the “active” cylinders will keep shut the discharge valve of the “inactive”, or “air bound,” cylinder. Then, the air or gas in this cylinder will be compressed and expanded by its reciprocating plunger and never leave the chamber. Similar effects occur in duplex and triplex pumps.

To overcome these difficulties, adequate provision for expelling the gas in the “air bound” cylinders must be present. Common practice is to totally relieve the pump of all discharge pressure during the start-up, after servicing.

Consider the operational advantage of a full-sized bypass line (return to tank) which substantially removes discharge pressure from all cylinders during the start. This requires a block valve on the discharge side and a full opening bypass valve on the other side.

For economy, the bypass (to tank) can be combined with the relief valve discharge line. This line must be full-sized, well supported, and sloped downward to avoid freezing in cold weather. (A frozen relief valve line provides no protection to either the pump or operating personnel!)

The ability of a reciprocating pump to be “self-priming” depends on the ratio of the swept (displaced) volume in the cylinder to the unswept (clearance) volume at the end of the stroke. This depends on the design of the fluid end and on the plunger size selected.

Choice of the largest size plunger for a particular fluid

end improves this compression ratio and so leads to “self priming”, or easy priming. Choice of the minimum size plunger sometimes leads to difficulties, especially with pumps that require frequent servicing, or which handle volatile liquids, or which contain substantial amounts of dissolved air or gas. An automatic bypass and purging system for these applications may be merited.

LUBRICATION

Pumps are shipped without oil from the factory. If the pump is fitted with a planetary gear reducer, it must be filled separately through its own fill port. Gear reducers should be filled to approximately the halfway point.

Myers Aplex Series pumps use S.A.E. 40 wt. nondetergent oil in the crankcase. This oil requires only a nonfoaming additive and should possess good water separation (antiemulsion) characteristics. Such oils are often labeled “industrial” or “turbine” quality lubricants. If these oils are not available, a good quality gear oil or EP oil may be substituted. See lubrication guidelines.

In temperate climates, oil viscosity selected should fall between 70 and 84 seconds Saybolt viscosimeter at 210° F. In arctic service, low pour point oils are needed.

After the first 500 hours of operation in a new pump, drain the oil. Refill with clean, fresh oil. Thereafter, change the oil every 1,500 hours or sooner if it becomes contaminated with water or dirt. Fill to the center of the sight gauge. Recheck after starting, adding oil to center of gauge while running.

The table below shows the quarts of oil needed for each pump.

Quarts of Oil	
15	18
MA-95L	MA-95M
MA-120L	MA-120M
MA-120L-HD	SC-170
SC-170L	SC-170H
	SC-170DD

V-BELT DRIVE

A properly designed, well-aligned V-belt will provide years of reliable, economical service if properly tensioned and kept dry, free of oil and ventilated.

Alignment is critical for long life. If the shaft axes are not truly parallel, or if the sheave grooves are not positioned in good alignment, some belts will carry most of the load, resulting in their disproportionate load share and may actually twist or turn over in the groove. Use a straight edge across the rim of the sheaves to detect and correct for misalignment.

SUGGESTED PIPING SYSTEM FOR PLUNGER PUMPS

NOTES

- 1) CENTERLINE OF PUMP SUCTION (INLET) TO BE SLIGHTLY HIGHER THAN CENTERLINE OF SUCTION (INLET) VALVE, SO ANY AIR IN SUCTION SYSTEM PROMPTLY REACHES THE PUMP AND IS EXPELLED.
- 2) SLOPE BYPASS SO LOW POINT DRAIN WILL FULLY EMPTY, RELIEF AND CHOKO VALVES AND ALL LIQUID IN BYPASS CIRCUIT.
- 3) DO NOT LOCATE PIPING OR OTHER EQUIPMENT IN FRONT OF OR ABOVE PUMP LIQUID END, PREVENTING SERVICING.
- 4) LOCATE CHARGING PUMP AT POINT SHOWN IF A CHARGING PUMP IS NECESSARY (AS FOR VOLATILE FLUIDS, FOR EXAMPLE).
- 5) IF DESIRED, A TWO-WAY MOTOR-OPERATED BYPASS VALVE MAY BE USED RATHER THAN A MANUAL TYPE. IT SHOULD BE DESIGNED TO OPEN AUTOMATICALLY WHILE STARTING OR STOPPING.
- 6) FEED LINE AND BYPASS LINE SHOULD FEED LIQUID INTO TANK BELOW MINIMUM LIQUID LEVEL.

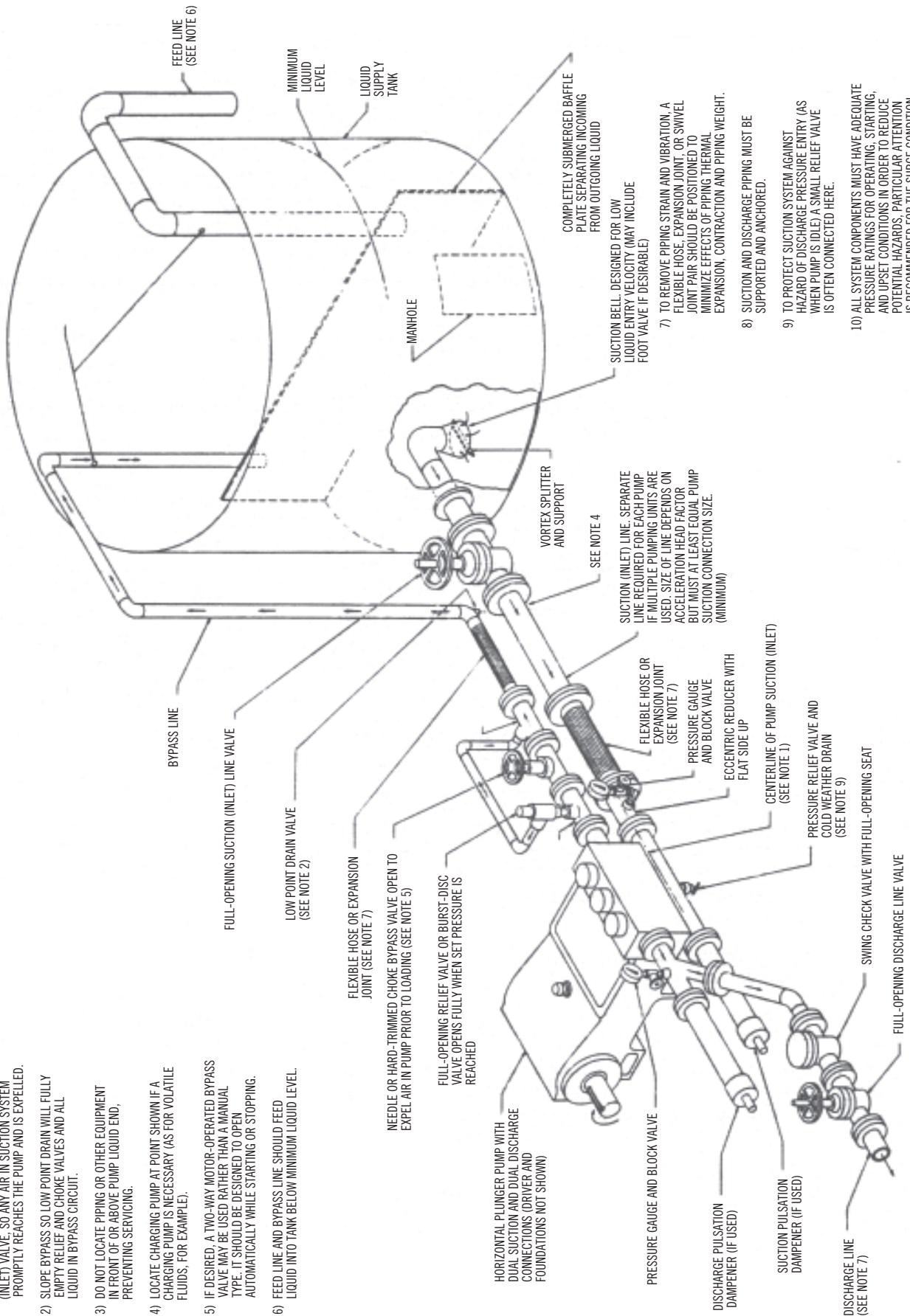

FLEXIBLE HOSE OR EXPANSION JOINT (SEE NOTE 7)

NEEDLE OR HARD-TRIMMED CHOKO BYPASS VALVE OPEN TO EXPEL AIR IN PUMP PRIOR TO LOADING (SEE NOTE 5)

FULL-OPENING RELIEF VALVE OR BURST-DISC VALVE OPENS FULLY WHEN SET PRESSURE IS REACHED

HORIZONTAL PLUNGER PUMP WITH DUAL SUCTION AND DUAL DISCHARGE CONNECTIONS (DRIVER AND FOUNDATIONS NOT SHOWN)

PRESSURE GAUGE AND BLOCK VALVE

DISCHARGE PULSATION DAMPENER (IF USED)

SUCTION PULSATION DAMPENER (IF USED)

DISCHARGE LINE (SEE NOTE 7)

PRESSURE RELIEF VALVE AND COLD WEATHER DRAIN (SEE NOTE 9)

SWING CHECK VALVE WITH FULL-OPENING SEAT

FULL-OPENING DISCHARGE LINE VALVE

CENTERLINE OF PUMP SUCTION (INLET) (SEE NOTE 1)

PRESSURE GAUGE AND BLOCK VALVE

ECCENTRIC REDUCER WITH FLAT SIDE UP

SUCTION (INLET) LINE SEPARATE LINE REQUIRED FOR EACH PUMP IF MULTIPLE PUMPING UNITS ARE USED. SIZE OF LINE DEPENDS ON ACCELERATION HEAD FACTOR BUT MUST AT LEAST EQUAL PUMP SUCTION CONNECTION SIZE. (MINIMUM)

VORTEX SPLITTER AND SUPPORT

SEE NOTE 4

SUCTION BELL, DESIGNED FOR LOW LIQUID ENTRY VELOCITY (MAY INCLUDE FOOT VALVE IF DESIRABLE)

7) TO REMOVE PIPING STRAIN AND VIBRATION, A FLEXIBLE HOSE, EXPANSION JOINT, OR SWIVEL JOINT PAIR SHOULD BE POSITIONED TO MINIMIZE EFFECTS OF PIPING THERMAL EXPANSION, CONTRACTION AND PIPING WEIGHT.

8) SUCTION AND DISCHARGE PIPING MUST BE SUPPORTED AND ANCHORED.

9) TO PROTECT SUCTION SYSTEM AGAINST HAZARD OF DISCHARGE PRESSURE ENTRY (AS WHEN PUMP IS IDLE) A SMALL RELIEF VALVE IS OFTEN CONNECTED HERE.

10) ALL SYSTEM COMPONENTS MUST HAVE ADEQUATE PRESSURE RATINGS FOR OPERATING, STARTING, AND UPSET CONDITIONS IN ORDER TO REDUCE POTENTIAL HAZARDS. PARTICULAR ATTENTION IS RECOMMENDED FOR THE SURGE CONDITION THAT WILL RESULT DOWNSTREAM OF THE RELIEF VALVE WHEN NORMAL DISCHARGE IS BLOCKED.

FEED LINE (SEE NOTE 6)

MINIMUM LIQUID LEVEL

LIQUID SUPPLY TANK

MANHOLE

COMPLETELY SUBMERGED Baffle PLATE SEPARATING INCOMING FROM OUTGOING LIQUID

BYPASS LINE

FULL-OPENING SUCTION (INLET) LINE VALVE

LOW POINT DRAIN VALVE (SEE NOTE 2)

FLEXIBLE HOSE OR EXPANSION JOINT (SEE NOTE 7)

NEEDLE OR HARD-TRIMMED CHOKO BYPASS VALVE OPEN TO EXPEL AIR IN PUMP PRIOR TO LOADING (SEE NOTE 5)

FULL-OPENING RELIEF VALVE OR BURST-DISC VALVE OPENS FULLY WHEN SET PRESSURE IS REACHED

HORIZONTAL PLUNGER PUMP WITH DUAL SUCTION AND DUAL DISCHARGE CONNECTIONS (DRIVER AND FOUNDATIONS NOT SHOWN)

PRESSURE GAUGE AND BLOCK VALVE

DISCHARGE PULSATION DAMPENER (IF USED)

SUCTION PULSATION DAMPENER (IF USED)

DISCHARGE LINE (SEE NOTE 7)

PRESSURE RELIEF VALVE AND COLD WEATHER DRAIN (SEE NOTE 9)

SWING CHECK VALVE WITH FULL-OPENING SEAT

FULL-OPENING DISCHARGE LINE VALVE

CENTERLINE OF PUMP SUCTION (INLET) (SEE NOTE 1)

PRESSURE GAUGE AND BLOCK VALVE

ECCENTRIC REDUCER WITH FLAT SIDE UP

SUCTION (INLET) LINE SEPARATE LINE REQUIRED FOR EACH PUMP IF MULTIPLE PUMPING UNITS ARE USED. SIZE OF LINE DEPENDS ON ACCELERATION HEAD FACTOR BUT MUST AT LEAST EQUAL PUMP SUCTION CONNECTION SIZE. (MINIMUM)

VORTEX SPLITTER AND SUPPORT

SEE NOTE 4

SUCTION BELL, DESIGNED FOR LOW LIQUID ENTRY VELOCITY (MAY INCLUDE FOOT VALVE IF DESIRABLE)

7) TO REMOVE PIPING STRAIN AND VIBRATION, A FLEXIBLE HOSE, EXPANSION JOINT, OR SWIVEL JOINT PAIR SHOULD BE POSITIONED TO MINIMIZE EFFECTS OF PIPING THERMAL EXPANSION, CONTRACTION AND PIPING WEIGHT.

8) SUCTION AND DISCHARGE PIPING MUST BE SUPPORTED AND ANCHORED.

9) TO PROTECT SUCTION SYSTEM AGAINST HAZARD OF DISCHARGE PRESSURE ENTRY (AS WHEN PUMP IS IDLE) A SMALL RELIEF VALVE IS OFTEN CONNECTED HERE.

10) ALL SYSTEM COMPONENTS MUST HAVE ADEQUATE PRESSURE RATINGS FOR OPERATING, STARTING, AND UPSET CONDITIONS IN ORDER TO REDUCE POTENTIAL HAZARDS. PARTICULAR ATTENTION IS RECOMMENDED FOR THE SURGE CONDITION THAT WILL RESULT DOWNSTREAM OF THE RELIEF VALVE WHEN NORMAL DISCHARGE IS BLOCKED.

After about one week of operation, new V-belts will have stretched somewhat. The motor must be moved on its slide base to re-establish proper belt tensioning.

Insufficient tension results in slippage, burning, squealing (especially during starting) and shortened belt life. Overtightening imposes excessive loads on pump and motor bearings and can cause early shaft fatigue failure.

Use the following table in adjusting V-belt tension:

Belt Cross-Section	Tension at Mid-Span	
	New Belts	Used Belts
"B"	5 - 6 lbs.	3-1/4 - 5 lbs.
"C"	9-3/4 - 13 lbs.	6-1/2 - 9-3/4 lbs.
"3V"	4 - 10 lbs.	3 - 7-1/2 lbs.
"5V"	17 - 30 lbs.	13 - 23 lbs.

Applying the above forces with a small spring scale, adjust motor position to provide the following deflection at mid-span:

Approx. Center Distance (Span), inches	Deflection, inches
16	1/4
22	3/8
28	7/16
32	1/2
40	5/8
48	3/4
60	15/16

Belts must be matched in pitch length. If one or two belts are slack, when the others are correctly tensioned, investigate for possible reasons. Correct any misalignment or lack of matching so each belt will transmit its load share.

Sheaves must be balanced to prevent abnormal vibration. Balancing weights must not be removed. Type "QD" sheaves must be evenly tightened on their tapered hubs to avoid rim wobble and severe lateral vibration. V-belts that snap and jerk will produce abnormal vibration and loads on both pump and motor or engine.

Run the pump several minutes at full load with belt guard removed, observing for uneven motion on the belt slack side, especially.

When an old V-belt drive becomes unserviceable, replace all belts, not just the broken or cracked belts. Do not operate belts on sheaves having worn, rusted, greasy or broken grooves. Shut off power to driver before servicing drive or pump.

WARNING: Do not operate without appropriate guards in place.

DIRECTION OF ROTATION

Before placing pump in operation, check that

crankshaft rotation agrees with the arrows cast on top of the power frame by briefly jogging the electric motor. Crankshaft rotation must be clockwise as viewed from the right side of pump.

If pump is gear driven, remember that the pinion shaft turns opposite the crankshaft, if using a single-reduction geared drive or in the same direction as the crankshaft when using a planetary gear.

AUTOMATIC (SAFETY) SHUTDOWNS

Carefully check all electric shutdown devices present, such as crankcase oil level, discharge pressure, vibration, lubricator oil level, motor thermostat, etc.

CRANKSHAFT ASSEMBLY

GENERAL

Myers Apex Series crankshaft suspension uses two single-row tapered bearings, which are shim adjusted to provide the correct running clearance.

Thorough cleaning of all components prior to assembly is essential.

Power frame, shaft, bearings and retainer must be scrupulously scrubbed with clean solvent (such as kerosene) before starting. Remove any oil, dirt, rust and foreign matter which might prevent the correct fit up.

Crankshaft journals are critical. Remove all burrs, rust spots, and nicks, paying special attention to the ground areas on which bearings and oil seals operate.

Connecting rods and crossheads may be installed either before or after installing the shaft in MA-120M pumps.

TAPERED ROLLER BEARINGS

Shaft and frame tolerances provide a tight (shrink) fit on the shaft and in the carrier. The best way to install the cone assembly (consists of the inner race, cage and rollers) on the shaft is to heat the cone assembly in an electric oven for 30 minutes at 300 to 400°F. No more! (Do not heat bearings with an acetylene torch. This ruins the bearings!) Using clean, insulated gloves, remove the hot cone assembly from the oven, promptly dropping it on to the shaft.

The cone assembly must contact the seat thrust face (not be cocked), and the large end of the rollers must be down. Do not hammer on the bearing. The soft steel cage is easily distorted, ruining its function as a roller separator and guide against skewing. If the cone does not contact its thrust face properly, it must be pressed into place using a specially machined sleeve (which

does not touch the soft steel cage). A hydraulic press is recommended if this difficulty arises.

CUP INSTALLATION

Tapered roller bearing cup (outer races) is a press-fit in the bearing carrier, using a hydraulic press. Cup must be pressed into a clean carrier until the race solidly abuts its shoulder (must not be cocked).

The tool or plate used for this must contact only the outer end face—not on the taper.

INSTALLING CRANKSHAFT

SHIM ADJUSTMENT OF TAPERED ROLLER BEARINGS

To provide for crankshaft thermal expansion, sufficient shims must be installed to provide .005" to .015" lateral end play, when shaft is cold. Shims must be placed only under the drive side bearing carrier. The lube oil housing has a gasket under it.

A feeler gauge and a 1" micrometer caliper are required. Install a trail shim set on one side of the pump. Tighten the flange bolts on this side only.

CAUTION: Lubricate the frame bores and the O-ring seals located in each carrier to prevent damage during entry. Oil the bearings.

Draw up the carrier, evenly tightening its cap screws. Rotate the crankshaft slowly by hand, seating all rollers into running position.

Measure the gap existing between the frame face and carrier flange. The correct thickness of the shim set to be installed equals the measure gap plus about .010". (No pre-load.)

After installing above shim set, a dial indicator may be used against the end of the shaft to confirm the shim selection. Bump the shaft in one direction and zero the dial indicator. Bump the shaft the opposite way. If shimming is correct, the shaft will move laterally from .005" to .010".

The recommended tightening torque for bearing retainer 5/8"-11UNC cap screws is 118 to 145 ft. lb.

INSTALLATION OF CRANKSHAFT OIL SEAL

Insert oil seal over the end of crankshaft and position it into the oil seal bore in the bearing carrier. Using a rubber mallet, tap it into the bore until the face of the seal is flush with the bearing carrier.

LUBE OIL PUMP ASSEMBLY

Lube oil pump and filter assemblies are employed in certain Myers Apex Series pumps. This assembly is installed after the shaft and its tapered bearings have been correctly set. Providing filtered oil under pressure (35 to 75 psi) to all crosshead pin bushings and crankpin bearings, this special gear pump is driven by a bolted-on drive shaft. Driver is made with a female drive square which drives the male square end of the lube oil pump shaft.

The driver shaft is piloted by the main bearing inner race cone and is secured to the crankshaft by four socket head cap screws. Stake their heads using a center punch to upset the adjoining metal.

The lube oil pump (Tuthill) is a gear type pump possessing a self-reversing sector which automatically switches suction and discharge connections in the event (not recommended) that the pump is caused to rotate opposite the correct direction. The lube oil pump is readily removed for inspection, repair, or replacement without disturbing any other pump component.

The lube oil pump shaft is journaled in a bronze bushing fitted into the bearing carrier. If this bushing becomes worn (check for contaminated crankcase oil), it must be promptly replaced. A worn bronze bushing will cause this pump to frequently lose its prime, and also may cause excessive wear in the pump rotor teeth.

DISASSEMBLY

After removing the connecting rod cap and cap bolts (note identifying marks on each cap so each may be later correctly reassembled onto its own rod) remove a bearing carrier from the frame. Two jack out tapped holes are provided in the flange of the carrier for this purpose. Support the shaft during removal to avoid damage.

The crankshaft may now be extracted, once all connecting rods are moved clear. Examine the crankpin surfaces for wear or corrosive pitting. The correct diameters of these journals are:

Crankpin Diameter 4.0000/3.9990"

If worn more than .010" undersize, crankshaft should be replaced, or an attempt to salvage it may be made at a shop well equipped to grind the crankpins which must be fully round, chrome plated, and finish ground to the above sizes. (Myers Apex Series does not perform this function.)

Crankshaft tapered roller bearings should be carefully examined for pitting, scoring or corrosion, and replaced as required. The cone and roller assembly

is most easily removed by first cutting away the cage using an acetylene cutting torch. Then heat the cone (inner race) with the shaft held vertically so cone will drop off due to its own weight. Avoid excessive heat on the crankshaft which tends to distort its geometry.

Cups (outer races) of tapered roller bearings may be extracted from bearing carrier using a conventional bearing puller tool of the automotive type (widely available). Do not attempt to use heat on a bearing carrier as this will result in severe distortion (out-of-round). Replace the bearing carrier if broken or out-of-round.

CONNECTING ROD, CROSSHEAD, EXTENSION ROD, CROSSHEAD PIN AND WIPER BOX ASSEMBLY/ DISASSEMBLY:

GENERAL

Myers Aplex Series connecting rod assemblies employ precision automotive type steel backed, babbitt-lined crankpin bearing halves which require no shims for clearance adjustment. This pump employs full circle (piston type) crossheads and hardened stainless steel extension rods, which are field replaceable.

Extension rods are provided with wrenching flats to permit tightening of the tapered thread into the crosshead, establishing accurate alignment while affording easy field installation.

Before beginning the assembly all parts must be scrupulously cleaned, removing all oil, dirt, rust, and foreign matter which prevent proper fitting, or which might tend to score the rubbing surfaces. Clean and examine the power frame bores for scoring and abnormal wear, especially wear of the lower crosshead guide way. Hone smooth, if rough.

Measure the bores of the frame using inside micrometers to determine abnormal frame wear if any.

Crosshead O.D.: 5.742/5.740 New Frame Bores: 5.749/5.742

Frame bores that have become worn more than .015" must be sleeved with a cast iron liner to re-establish correct geometry and alignment. Contact Myers Aplex Series concerning the repair of badly worn frame bores.

Smooth any rough corners and edges on the crosshead skirts, using fine emery cloth. Examine and clean the female tapered threads and wrist pin holes.

INSTALLING WRIST PIN BUSHINGS

The wrist pin bushing is precision machined bearing bronze which is press fitted into the eye of the connecting rod.

Bushing O.D.: 2.256/2.255 Connecting Rod Eye: 2.251/2.254
--

Carefully align the bushing with its hole, and after applying oil to bushing O.D. use a hydraulic press to force it home. When a bronze bushing is pressed into place, the I.D. (bore) of the bushing is reduced somewhat, owing to the extent of press fit. Therefore, a clean, new wrist pin should be inserted into the bushing bore to establish that running clearance has been obtained. The running clearance between the wrist pin and installed bushing is:

New Pin O.D.: 2.0238/2.0233 Installed Bushing Bore: 2.0251/2.0261
--

Oil Clearance.....0013/.0028"

Replacement bushings are furnished prebored by Myers Aplex Series which usually eliminates the need to ream the installed bushing bore. However, due to slight variations in finishes and tolerances it sometimes happens that more than predicted contraction of the I.D. occurs. This occurrence results in a slight interference which may be eliminated by lightly honing the bore of the bronze (not by reducing the pin size!) An automotive engine repair shop usually is equipped with power honing machines capable of smoothly finishing the bushing bore. Bore of bushing must be round and free of taper.

PINNING THE CROSSHEAD

A pressfit is employed between the crosshead pin and crosshead to secure the pin against any motion. A hydraulic press is employed to force the pin through the bosses of the crosshead.

A mishap during insertion can occur causing the ruin of the pin or the crosshead, if during application of pressure:

- (a) Pin is not aligned absolutely square with the crosshead.
- (b) Crosshead is not supported on v-blocks so it can roll while under load.
- (c) Connecting rod is not fully supported so pin cannot enter the bushing without damage to it.

This will damage the bushing.

- (d) Failure to oil pin O.D. and crosshead bores, to prevent galling. Use clean motor oil.

After installing the pin, carefully check the crosshead O.D. to see if it is out-of-round. If so, a smart blow with a rubber mallet will restore the crosshead O.D. into its original roundness.

ORDER OF ASSEMBLY

The connecting rod/crosshead assembly is installed after the assembly of the crankshaft. In these models, the rod and crosshead will pass through the wiper box wall bore. With the frame in the horizontal position, load the rods through the cradle.

PRECISION CRANKPIN (CRANKTHROW) BEARINGS

Myers Apex Series pump crankpin bearings require no shimming to establish correct running clearance. Precise machining of the connecting rod, caps and crankpin journals is necessary to achieve this convenience.

New Crankpin O.D.: 4.000/3.999
New Connecting Rod Bore: 4.232/4.233

Crankpins that are worn out-of-round, tapered, or badly scored should either be discarded or perhaps salvaged by grinding undersize, hard chrome-plated, and finish ground to above diameter. (Myers Apex Series does not offer this service.)

Connecting rod/cap bore must be perfectly round and within above sizes and free of taper. Discard if elliptical or tapered as the result of abnormal heating. Each cap and rod is match-marked for correct identification. Take care that each cap is reinstalled properly with its companion rod. Bearing halves are identical and are prevented from rotating by tongues which fit into slots in the cap.

Check that all oil holes are clean and fully open. Grit is the greatest enemy of bearings, however precisely manufactured. Hence, all surfaces must be perfectly clean and lightly oiled prior to assembly. Remove any burrs or sharp corners which prevent the perfect fitting of these precision bearings. Using a torque wrench, tighten cap bolts as follows:

Thread Size: 1/2" - 13UNC
Tightening Torque: 60-75 Ft. Lb.

Specified torque, applied to clean, well oiled threads and bearing faces, will create tensile stresses in the cap bolts from 90,000 to 110,000 psi, approx. and will provide correct initial tension. Myers Apex Series pumps use high strength cap bolts suitable for these initial loadings, maintained by hardened spring

lockwashers. MA-120M use hardened lock washers and other models use safety wire to maintain the required tightness.

After all rods and caps are secured, slowly turn the crankshaft to be sure no bearing is in a bind.

Using a flashlight, examine the location of each connecting rod (eye end) within its crosshead. Rods must not touch any crosshead boss or skirt.

OIL SCOOP

MA-120M also employ oil scoops which are cast integrally with the power frame and are machined to lightly contact the crankshaft cheek. No adjustment is required.

WIPER BOX ASSEMBLY

GENERAL

Extension rod wiper boxes (sometimes referred to as the diaphragm stuffing box, or stripper housing assembly) serve two important functions: retention of crankcase oil in the power end and exclusion of dirt and water.

Myers Apex Series has developed a unique sealing set which operates on a hardened and ground stainless steel extension rod (often called "pony" rod), and a steel baffle disc affording protection against leaking plunger packing. The seals require no adjustment, only correct and careful assembly.

"POLY PAK" SEAL

This seal keeps oil from leaking out of the power frame. Developed by the Parker Seal Group, this patented rod seal employs a soft nitrile rubber O-ring to energize a special hard polyurethane Molythane® shell by forcing the inner lip against the rod and the outer lip against the housing bore, as shown.

The Poly Pak seal is inserted into its counter bore with its lips directed toward the oil in the crankcase. (Will not work if installed backward!)

MECHANICAL OIL SEAL

The oil seal is to keep contamination out of the power frame. With the box positioned in a hydraulic press, install the backup seal against the Poly Pak seal, with the lips of both seals facing downward.

The mechanical seal contains a garter spring. Check to see that this spring is still properly located and in its position. The mechanical seal has a metal case which serves to force the Poly Pak seal into its cavity,

energizing its lips. Apply oil lightly to the bore of the box before pressing each seal into its counterbore.

INSERTING THE PLUNGER

Insert the extension rod through the wiper seals with the tapered thread and entering first. Do not move the extension rod through the seals with wrenching flats entering first. The sharp corners on the wrenching flats may damage the seal lips, resulting in oil leakage.

With extension rod inserted through the wiper box seals, thread the tapered threads (must be clean!) into the tapered crosshead female threads. Firmly tighten and apply torque to the wrenching flats only. Never damage the extension rod ground surfaces!

Then fasten the wiper box to the power frame by tightening the cap screws. Oil leakage between frame face and wiper box is prevented by use of an O-ring.

STUFFING BOX, PACKING AND PLUNGER ASSEMBLIES

GENERAL

Myers Aplex Series pumps all feature field removable and replaceable stuffing boxes with plungers separable from the extension rods.

If desired, the boxes, plungers, and packing units may be installed (or removed) as a unit assembly, permitting service outside the pump. All boxes are retained by four studs and nuts, and are centered in the frame bore, ensuring correct alignment.

The plungers may also be removed separately (without box removal) to facilitate repacking. With this option, the necessary space required to remove plunger, it is first necessary to remove the extension rod.

SPRING LOADED PACKING

Note that the gland is screwed tightly onto the box and contacts its face. The spring is providing all of the initial compression and adjustment. No adjustment is provided by the gland.

Since the force exerted by the spring is contingent on the space provided for it, the correct lengths of all rings is essential for good tensioning.

Spring:

A stiff Inconel® spring, which closely fits the bore of the stuffing box, is used in this assembly. This spring is compressed in a vise to the operating length required plus 0.25" and tied with waxed nylon spot tie cord. The cord is looped over the ends of the spring through the

coils and tied to maintain the length mention above. Each spring is assembled into the stuffing box. Note that the spring does not contact the plunger.

Spring-Guide Ring:

Plungers are heavy and the importance of a well-fitted guide ring that carries this weight is often overlooked. Discard any guide ring that becomes worn or scored, as it will then not serve its purpose. It should fit snugly in the box. Apply oil generously to this ring.

Spring Loaded Packing:

Three rings of chevron or compression packing are installed next. For compression packing, install them with the skive intersections 180° apart to discourage leaking.

Gland Ring:

This ring also fits the plunger and helps support the plunger weight. Discard it if bore is worn, rough or out-of-round. Lightly oil the ring before insertion. The gland ring fits all packing.

J-STYLE STUFFING BOX & PLUNGER ASSEMBLY (STYLES 838 & 858)

Styles 838 and 858 packing correctly installed with all packing lips facing toward the fluid pressure. Note that two units of Styles 838 and 858 packing are positioned ahead of the lantern ring, and one unit is positioned behind it. Thus lubricant entering the lantern ring is forced toward the pressure.

Throat Bushing:

Plungers are heavy and the importance of a well fitted throat bushing that carries this weight is often overlooked. Discard any throat bushing that becomes worn or scored, as it will not then serve its purpose. It should fit snugly in the bottom of the box. Apply oil generously to this ring.

Styles 838 and 858 Packing:

Styles 838 and 858 are a non-adjustable type packing which depends solely on hydraulic pressure to energize the sealing lips. (Gland-tightening forces do not energize the lips.) Tightening and hydraulic end thrust loads are transmitted entirely through the center support portions of each ring.

The flattened portions of the rings are large enough to withstand overtightening. Do not attempt to adjust this type packing. It should be kept thoroughly tightened at all times. (Running it loose will ultimately ruin the bore of the box.)

Running it loose will not usually cause it to drip at all, but it can ruin the box in time.

Lightly oil each ring and the box bore and then lightly tap in each ring separately with the rings facing

correctly. This is most easily done before installing the plunger.

Lantern rings are provided with O.D. and I.D. reliefs and two (or more) oil holes to allow lubricant to reach the plunger. After the last unit of Styles 838 and 858 packing is in place, generously oil the lips of all seal rings to ease plunger entry.

INSERTING THE PLUNGER

Apply oil liberally to plunger O.D. and lightly tap it through the packing.

A soft rubber mallet is recommended to avoid any damage to the plunger face or its threads. Remember: The fragile nature of packing rings and plunger surfaces deserves your respect and avoidance of careless damage to these key elements!

INSTALLING THE GLAND

Considerable downward pressure on the gland is required to compress the spring, to move the packing into location, and to start the threads of the box.

Once the gland threads are started, screw it down completely until it makes up tightly against the face of the box, for spring loaded packing. For Hi/Lo, J-Style or Gland adjusted packing, tighten the gland until it is seated firmly against the packing.

INSTALLING THE STUFFING BOX

Myers Apex Series stuffing boxes derive their alignment from the bores of the power frame and the faces of the fluid end. So these surfaces must be cleaned of rust, scale, and dirt before assembly is begun. Wash all contacting surfaces with clean solvent and dry with a clean shop towel.

A nitrile rubber seal is used to seal between the face of the fluid end (must be flat, clean and smooth) and the face of the box. Replace if damaged.

All stuffing boxes are retained by four large studs and nuts which extend through the power end, serving to clamp the box and the powerframe tightly against the fluid end face. These four stud nuts must be evenly tightened.

Using a socket, socket extension, and torque wrench, tighten clean, well-oiled threads and nut faces.

Stud Threads	
1" – 8UN at 440–465 Ft. Lb.	1" – 8UN at 400–465 Ft. Lb.
SC-170	SC-170L
SC-170H	MA-120L
MA-95M	MA-120L-HD
MA-120M	

FLUID END

Disassembly/Assembly:

When removing fluid end, pump several gallons of clean water through before service is performed to remove contamination left behind. Inspect fluid end for stress cracks to determine if replacement is necessary. Inspect and clean all openings for contamination.

Disconnect suction/discharge piping before disassembling the fluid end. Remove the stuffing boxes and nuts between the fluid and power end. Support the fluid end while sliding the assembly away from the power frame.

Reverse procedure to reassemble and torque all fluid end nuts to 750 Ft. Lbs.

CONNECTING THE PLUNGER

Install the metal baffle plate on the extension rod and roll the pump slowly until the extension rod male threads just touch the mating plunger female threads.

Applying a pipe wrench to plunger knurled area, thoroughly tighten the connection. Do not use a "cheater" when connecting plunger to extension rod. (Serves no useful purpose, and may damage the connection!)

PACKING

Packing life for aramid fiber packing may be improved in some applications by regular, systematic lubrication. An optional force feed lubricator assembly is often recommended especially for pumps on continuous duty. This provides regular, controlled supply of lubricant lowering friction and heat.

Additionally, the regular application of the correct lubricant aids dissolving of salt and gyp tending to build up on the plungers in produced water applications. For this service, Rock Drill Lubricant is a popular and effective packing lubricant.

Plungers in CO₂, ethane, or other very cold liquid services may use brake fluid. This fluid does not congeal into a solid which cannot enter the packing. Consider the use of an air-sealed cradle into which dry (instrument) air may be directed, excluding the moisture which causes plunger icing especially in very humid conditions.

Packing lubricant for pumps on light hydrocarbons, hot water, lean oil, naphtha, or gasoline often requires experimentation.

A good start is to use steam cylinder oil. Castor oil is sometimes successful as a packing lubrication for liquid propane and butane services, at ambient temperature.

In pumps placed in arctic service, a special low pour point oil is indicated.

Packing lubrication is not permitted on some services, such as amine, food stuffs, etc., and other packing styles

and materials may be required.

PLUNGERS

Myers Apex Series offers its own unique product: the Myers Apex Series Rokide® plunger. This premier quality plunger consists of a chromium-oxide deposition on a solid stainless steel body.

Ordinary handling will not damage this fine product. Avoid striking the coated surface (black) during installation. Apply light forces only on the ends of the plunger. Do not hammer or pry.

All threads on Myers Apex Series plungers must be clean and oiled before assembly. Stainless steel (although very corrosion resistant) has a tendency to gall and seize. To avoid this, an anti-seizing lubricant is well worth its use. Apply oil to the threads and the rubbing surface.

Myers Apex Series can supply solid ceramic plungers on order. This plunger is very fragile, vulnerable to thermal and mechanical shock, and must be handled with the greatest care. Use only a rubber mallet to insert it into the packing. Other plunger types are available upon request.

DISC VALVE SYSTEMS AND ABRASION RESISTANT

GENERAL

Myers Apex Series has developed a unique setting/puller system permitting quick, easy and safe methods of installing and removing tapered seat valves.

The system allows servicing without distortion of the seat, with minimum effort and no damage to fluid end tapers or seat.

DISC VALVE AND ABRASION RESISTANT VALVE CONSTRUCTION

The Myers Apex Series valve is a precision made subassembly using threads cut into the rim of seat for use with Myers Apex Series setting/pulling tool. These threads do not deteriorate as proved by field experience. By locating these on the rim, setting/pulling forces are now applied only to the rim of the seat, never to the webs (or "spokes"), or to the center section. Distortion of the seat is eliminated.

Access to these seat threads is provided by the removal of the valve cage on abrasion resistant valve or the spring retainer on disc valves which is screwed onto the seat. An anti-seizing lubricant applied to all threads is good insurance against future difficulty.

SETTING THE VALVE SEAT

Effective pressure-sealing between tapered (male) seat and tapered (female) fluid end deck is possible only if the tapers are absolutely clean and dry just prior to installation. Thoroughly clean surfaces using a clean solvent. Dry with a clean shop towel.

Examine the cleaned fluid end deck tapers, using a flashlight, and remove all deposits of gyp, salt, or other incrustation. Lightly emery cloth any minor imperfections found in the deck taper.

The puller stem and puller head are provided with tapered (locking) threads. Screw them together using two pipe wrenches applied to the knurled areas provided. Then screw the valve seat onto the puller head by hand until it shoulders against the puller shoulder. Do not tighten.

Lower the seat and puller assembly into the fluid end, squarely setting the seat into the deck. Then pound the top of the stem with a 6 pound hammer.

Unscrew the head and stem from the seat using a 1/2" bar (or screwdriver) into the hole provided at the top end of the stem.

INSTALLING O-RINGS, ABRASION RESISTANT SPRING AND CAGE

Install nitrile O-ring over the threaded section of the seat and position it at the bottom of the threads. Install the polyurethane insert into the valve. The insert may be heated in hot water to make it flexible enough to stretch over the valve. Position the valve into the seat. Install the valve spring. Apply anti-seizing lubricant to the threads of the valve cage and screw the cage on to the threaded valve seat with cage setting tool.

INSTALLING DISC, SPRING, DISC VALVES AND STEM:

Myers Apex Series offers discs of Acetol resin, of 17-4PH S.S. hardened and ground, and of titanium alloy.

Position the disc and Inconel® spring on the seat, aligning the hole in the disc with the stem threads in the seat center.

The stem, spring retainer, and locknut are shipped from Myers Apex Series already assembled and tightened with a torque wrench with "Loc-Tite" sealant added to the top stem threads only.

<u>Stem Threads</u>	<u>Tightening Torque</u>
1/2"-13UNC	65-75 ft. lb.

Use an anti-seizing lubricant in these threads. This is very necessary when seats and stems of Type 316 stainless steel are selected (optional) to prevent galling. Cleanliness of threads and other contacting

surfaces
is of paramount importance in the assembly of all
valve elements.

VALVE SPRING OPTIONS

All Myers Apex Series valve springs are made of Inconel® material, precisely designed and fabricated. Unless otherwise specified, the standard spring is furnished. It provides excellent results in the great majority of applications.

Pumps employed in marginally available NPSH conditions may require a “softer” spring, to reduce the required NPSH. For these special conditions, Myers Apex Series can supply “Light” valve springs which exert lower pressure on the valve disc. The use of “Light” valve springs may be limited by the choice of plunger size and/or limited by the chosen speed of the pump. “Light” valve springs may be impractical for pump models fitted with their maximum plunger size, or which operate near top speed rating as disc bouncing and erratic seating may occur. Contact Myers for more information.

VALVE DISC OPTIONS

Myers Apex Series acetal resin discs made of Acetol are machined flat and smooth to produce perfect sealing on the lapped-flat face of the seat. Used successfully in thousands of applications, these discs are light, slightly flexible under load, and seal well, even at high pump speeds, providing smooth pump action.

Acetal resins are very resistant to most corrodents, are not usually suitable where fluid temperatures above 120 degrees are met. Nor do they afford long life at extreme pressures. Pressure limitations depend on valve size. But continuous valve operation at pressures above 2,500 psi usually indicates the need of metal valve discs.

For higher temperatures or pressures, Myers Apex Series offers lapped flat, hardened Type 17-4PH stainless discs, or titanium alloy discs. These metal discs are less tolerant of any fine grit in the liquid and are noisier than the acetal resin disc.

PULLING THE VALVE SEAT

First drain the fluid end entirely. For abrasion resistant valves, use the cage wrench to unscrew the cage from the seat. For disc valves unscrew the stem from the seat. Remove the cage, spring and valve from the fluid end. Attach the Myers Apex Series puller head to the puller stem, tighten their tapered threads with a pipe wrench applied to the knurled areas of the puller

stem and head. Lower the stem and head into the fluid end and engage the threads of the head onto the seat threads.

Using a 1/2" bar (or screwdriver), rotate the head clockwise and thread it fully onto the seat. But do not tighten.

Slide the bridge over the stem. Clean and oil the stem threads. Oil the face of the wing nut. Thread wing nut down onto the stem, seating it on the bridge top firmly. Extract the seat from the pump by striking the wing nut with a heavy hammer. A hydraulic ram may also be used. Stand clear of the pump when applying heavy tonnage, as the entire assembly will jump violently upward when the pulling energy is suddenly released!

The Myers Apex Series puller/setting tool and gauge tool are custom designed and built for each specific Myers Apex Series pump model. The same puller head is used on both suction and discharge seats. The bridge is made to fit each model, and its proper use will not damage the valve cover gasket machined counterbore on the top of the fluid end.

SALVAGE OF WORN SEATS

Rough valve seat faces may often be renewed by lapping or grinding, if not deeply fluid-cut.

Perfect flatness is required. A surface grind, followed by lapping on a lapping plate, provides excellent smoothness and the flatness needed for good sealing and smooth running. Metal valve discs may sometimes be salvaged by grinding or lapping, if not deeply cut or cracked.

Acetol discs are relatively inexpensive and salvage is seldom worthwhile. Replace the stem, if severely worn. Inconel® valve springs rarely require replacement.

OTHER PUMP BRANDS

Myers Apex Series Industries can provide its unique (patented) valve to fit nearly all brands and models of multiplex pumps. An Myers Apex Series seat setting/puller tool is available too.

TROUBLE LOCATION AND REMEDY

Trouble	Possible Cause	Remedy
Excessive heat in power end. (Above 180°F)	Pump operating backward.	Correct rotation.
	Insufficient oil in power end.	Fill to proper level.
	Excessive oil in power end.	Drain to proper level.
	Incorrect oil viscosity.	Fill with correct oil.
	Overloading.	Reduce load.
	Tight main bearings.	Correct clearance.
	Drive misaligned.	Realign.
	Belts too tight.	Reduce tension.
	Discharge valve of a cylinder(s) stuck open.	Fix valve(s).
	Insufficient cooling.	Provide adequate cooling for oil or reduce ambient temperature.
	Pump speed too low.	Increase speed.
Pump fails to deliver required capacity.	Speed incorrect. Belts slipping.	Change drive ratio or tighten belts (if loose). Correct motor speed.
	Air leaking into pump.	Seal with compounds.
	Liquid cylinder valves, seats or plungers worn.	Reface or lap valves and seats; replace packing or plungers.
	Insufficient NPSHA.	Increase suction pressure.
	Pump not filling.	Prime pump.
	Makeup in suction tank less than displacement of pump.	Increase makeup flow. Reduce pump speed.
	Vortex in supply tank.	Increased liquid level in supply tank. Install vortex breaker.
	One or more cylinders not pumping.	Prime all cylinders. Allow pump to operate at low pressure through bypass valve to eliminate vapor.
	Suction lift too great.	Decrease lift. Raise tank level.
	Broken valve springs.	Replace.
	Stuck foot valve.	Clean.
	Pump valve stuck open.	Remove debris beneath valve.
	Clogged suction strainer.	Clean or remove.
	Relief, bypass, pressure valves leaking.	Repair.
Suction and/or discharge piping vibrates or pounds.	Piping too small and/or too long.	Increase size and decrease length. Use booster pump. Use suction and/or discharge pulsation dampeners.
	Worn valves or seats.	Replace or reface.
	Piping inadequately supported.	Improve support at proper locations.

TROUBLE LOCATION AND REMEDY

Trouble	Possible Cause	Remedy
Pump vibrates or pounds.	Gas in liquid.	Submerge return, supply or makeup lines in suction supply tank. If operating under a suction lift, check joints for air leaks.
	Pump valve stuck open.	Remove debris beneath valve.
	Pump not filling.	Increase suction pressure.
	One or more cylinders not pumping.	Prime all cylinders. Allow pump to operate a low pressure through bypass valve to eliminate vapor.
	Excessive pump speed.	Reduce. Check drive ratio.
	Worn valves or seats.	Replace or reface.
	Broken valve spring.	Replace.
	Loose plunger.	Tighten.
	Loose or worn bearings.	Adjust or replace.
	Worn crossheads or guides.	Replace.
	Loose crosshead pin. Loose connecting rod cap bolts.	Adjust or replace.
	Pump running backward.	Correct rotation.
	Consistent knock.	Water in power end, crankcase.
Worn or noisy gear.		Replace
Worn or loose main bearing, crank pin bearing, wrist pin bushing, plunger, valve seat, low oil level. NOTE: High speed power pumps are not quiet. Checking is necessary only when the sound is erratic.		Adjust or replace. Add oil to proper level.
Packing failure (excessive).	Improper installation.	Install per instructions.
	Improper or inadequate lubrication.	Lubricate per instructions.
	Improper packing selection.	Change to correct packing.
	Scored plungers.	Replace.
	Worn or oversized stuffing box bushings.	Repair or replace. Check bore and outside diameter of bushings frequently. (Many times plungers are replaced and bushings ignored.)
	Plunger misalignment.	Realign. Plungers must operate concentrically in stuffing box.
Wear of liquid end parts.	Abrasive or corrosive action of liquid.	Check valves and seats frequently at start-up to determine schedule for replacing, etc. Eliminate sand, abrasive, air entering pump.
	Incorrect material.	Install correct materials.
Liquid end cylinder failure.	Air entering suction system.	Eliminate air. NOTE: Pitting often leads to hairline cracks which ends in cylinder failure.

TROUBLE LOCATION AND REMEDY

Trouble	Possible Cause	Remedy
Wear of power end parts (excessive).	Poor lubrication.	Replace oil as recommended in instructions. Keep oil clean and at correct temperature. Be sure oil is reaching all bearings.
	Overloading.	Modify pump or system to eliminate overload.
	Liquid in power end.	Drain power end. Eliminate cause or source of liquid entering power end. Relubricate.

Power Frame Assembly; Connecting Rod, Crosshead & Wiper Box Assembly

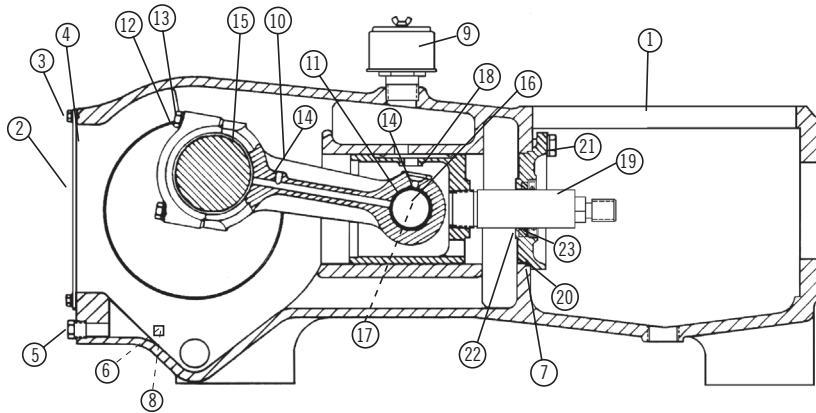

SC-170DD			
Item	Quantity	Description	Part Number
1	1	Power Frame	7204-0305-00K
2	1	Crankcase Cover	7204-0304-00C
3	14	3/8"NC Hex Head Cap Screw x 3/4" Long	100-038034-273
4	1	Gasket, Crankcase Cover	7502-1035-00B
5	1	1/2" Pipe Plug, Hex Head	170-012002-237
6	1	Dipstick	7204-1139-00A
7	3	O-Ring, Nitrile Rubber	001500421
8	1	1/2" Pipe Plug, Socket Head	170-012003-237
9	1	Breather, Crankcase, 1-1/4" NPTM	7602-3001-00A
10	3	Connecting Rod subassembly, which includes:	7204-0311-00D
11	3	Wrist Pin Bushing	7204-0310-00B
12	6	Connecting Rod Bolts	7204-0312-00A
13	6	1/2" Lockwashers, Spring Medium	154-012087-244
14	6	1/8" Pipe Plugs, Sq. Head (not shown)	170-018003-405

SC-170DD			
Item	Quantity	Description	Part Number
15	3	Crankpin Bearing Pair, w/Oil Groove	7204-0073-10K
16	3	Wrist Pin	7204-0005-00A
17	3	3/8"NC Socket Hd. Set Screw, Nylok - 1/2" Long	119-038034-999
18	3	Crosshead	7204-0309-00C
19	3	Extension Rod	7204-0065-10B
20	3	Wiper Box	7204-1352-00C
21	6	5/8" Hex Head Cap Screw x 1-1/2" long	100-058112-273
22	3	Seal, Wiper Box	145-200236-503
23	3	Seal, Wiper Box	145-200212-503

Power Frame Assembly; Connecting Rod, Crosshead & Wiper Box Assembly

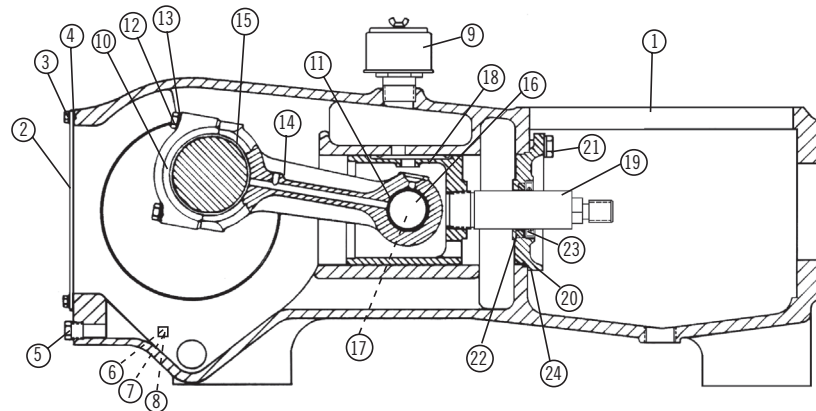

MA-95L, MA-95M, MA-120L, MA-120L-HD, MA-120M, SC-170L, SC-170, SC-170H			
Item	Quantity	Description	Part Number
1	1	Power Frame	7204-0305-00K
2	1	Crankcase Cover	7204-0304-00C
3	14	3/8"NC Hex Head Cap Screw x 3/4" Long	100-038034-273
4	1	Gasket, Crankcase Cover	7502-1035-00B
5	1	1/2" Pipe Plug, Hex Head	170-012002-237
6	1	Oil Level Sight Gage	7602-3000-00A
7	1	1/4" Pipe Nipple, Std. Wt. - 2" Long	157-014200-235
8	1	1/2" Pipe Plug, Socket Head	170-012003-237
9	1	Breather, Crankcase, 1-1/4" NPTM	7602-3001-00A
10	3	Connecting Rod subassembly, which includes:	7204-0311-00D
11	3	Wrist Pin Bushing	7204-0310-01B
12	6	Connecting Rod Bolts	7204-0312-00A
13	6	1/2" Lockwashers, Spring Medium	154-012087-244
14	6	1/8" Pipe Plugs, Sq. Head	170-018003-405

MA-95L, MA-95M, MA-120L, MA-120L-HD, MA-120M, SC-170L, SC-170, SC-170H			
Item	Quantity	Description	Part Number
15	3	Crankpin Bearing Pair, w/Oil Groove	7204-0073-10K
16	3	Wrist Pin	7204-0005-00A
17	3	3/8"NC Socket Hd. Set Screw, Nylok - 1/2" Long	119-038034-999
18	3	Crosshead	7204-0309-00C
19	3	Extension Rod	7204-0065-10B
20	3	Wiper Box	7204-0306-00C
21	6	5/8" Hex Head Cap Screw x 1-1/2" Long	100-058112-273
22	3	Poly Pak Ring 2" ID. x 2-3/4" OD.	145-200234-999
23	3	Oil Seal	145-200300-999
24	3	O-Ring, Nitrile Rubber	001500421

Crankshaft Assembly 4" Stroke; Right-Hand and Left-Hand Drive; Right-Hand Shown

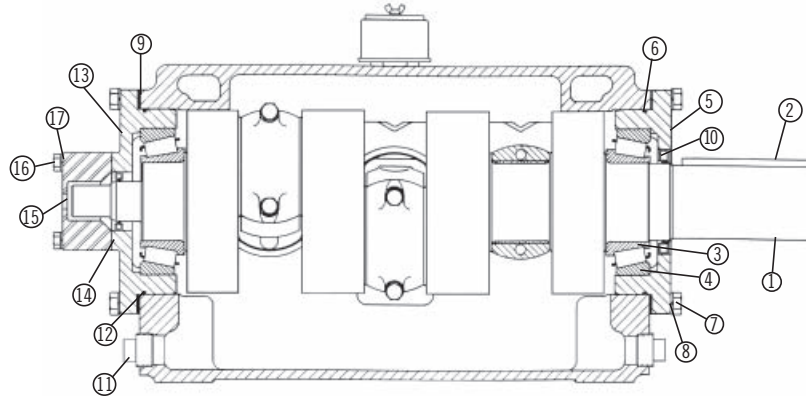

MA-95L, MA-95M			
Item	Quantity	Description	Part Number
		Crankshaft Assembly (includes items 1 & 2)	PE103K
1	1	Crankshaft	7204-0019-40D
2	1	Drive Key	146-078634-236
		Crankshaft Kit (includes items 1, 2, 3 & 4)	PE103KB
3	2	Bearing Cone, Tapered Roller	203-168000-999
4	2	Bearing Cup	202-458000-999
5	1	Bearing Carrier, Drive Side	7204-0018-00C
6	2	O-Ring, Nitrile Rubber	110-000271-201
7	12	5/8"NC Hex Head Cap Screw 1-3/4" Long	100-058134-273
8	12	5/8" Lockwasher, Spring Medium	154-058108-244
9	2	Shim Set	7502-0293-00A

MA-95L, MA-95M			
Item	Quantity	Description	Part Number
10	1	Oil Seal, Drive Side	145-393538-999
11	2	Frame Plug	7204-0315-00A
12	2	O-Ring, Nitrile Rubber	110-000210-201
13	1	Bearing Carrier, Packing Lubricator Side	7204-0017-10B
14	1	Oil Seal, Packing Lubricator Side	145-200300-999
15	1	Cover, Stub Shaft*	7204-0099-00A
16	2	1/2"NC x 3" Long Hex Hd. Cap Screw*	100-012300-273
17	2	1/2" Lockwasher, Spring Medium*	154-012087-244

* Items 15 through 17 are required only if packing lubricator is not ordered.

Crankshaft Assembly 4-1/4" Stroke; Right-Hand

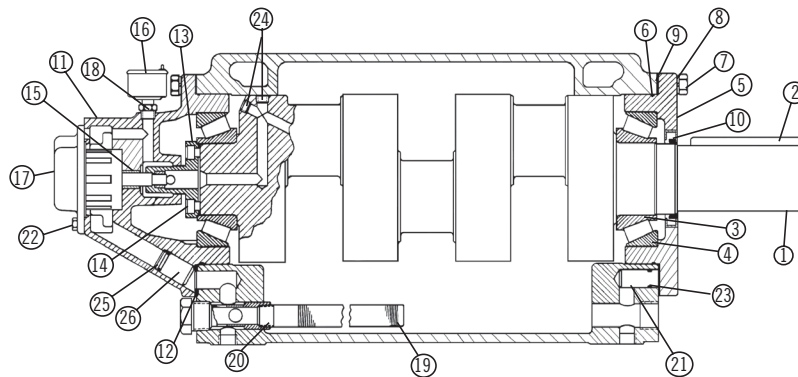

MA-120L, MA-120M			
Item	Quantity	Description	Part Number
		Crankshaft Assembly (includes items 1 & 2)	PE102K
1	1	Crankshaft	7204-0313-00D
2	1	Drive Key	146-078634-236
		Crankshaft Kit (includes items 1, 2, 3, & 4)	PE102KB
3	2	Bearing Cone, Tapered Roller	203-168000-999
4	2	Bearing Cup	202-458000-999
5	1	Bearing Carrier, Drive Side	7204-0018-00C
6	2	O-Ring, Nitrile Rubber	110-000271-201
7	12	5/8"NC Hex Head Cap Screw 1-3/4" Long	100-058134-273
8	12	5/8" Lockwasher, Spring Medium	154-058108-244
9	2	Shim Set	7502-0293-00A
10	1	Oil Seal, Drive Side	145-393538-999
11	1	Bearing Carrier, Lube Oil Pump Side Assembly [*Includes item 15, below]	7204-0324-00E
12	1	Gasket	7204-0323-00A

MA-120L, MA-120M			
Item	Quantity	Description	Part Number
13	1	Bearing Retainer & Lube Oil Pump Driver Assembly	7204-0322-01B
14	4	1/2"NC x 1" Lg. Socket Hd. Cap Screw, Nylok	272-012100-999
15	*	Pump Shaft Bushing - One per item 11	7204-0320-00A
16	1	Switchgauge, Murphy	7509-0008-00A
17	1	Lube Oil Pump	7204-0325-00K
18	1	3/8" x 1/8" Hex Pipe Bushing, Hex, Iron	161-038018-451
19	1	1" x 15" Oil Filter	7602-3005-00A
20	1	1-1/4" Oil Filter Plug	7204-0314-00A
21	1	Frame Plug, Drive Side	7204-0315-00A
22	8	5/16"NC x 5/8" Lg. Hex Hd. Cap Screw	100-516078-273
23	1	O-Ring, Nitrile Rubber	110-000210-201
24	2	3/8" Pipe Plug, Socket Hd.	170-038003-237
25	1	O-Ring, Nitrile Rubber	110-000023-201
26	1	Check Valve, Brass	7509-0012-00A

Crankshaft Assembly 4-1/4" Stroke; Right-Hand and Left-Hand Drive

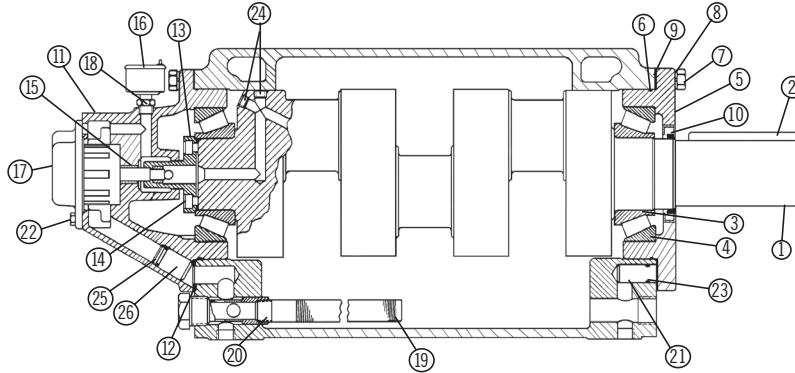

MA-120L-HD, SC-170L, SC-170, SC-170H			
Item	Quantity	Description	Part Number
1	1	Crankshaft Assembly (includes items 1 & 2)	PE301K
		Crankshaft Forged and Nitrided	7204-0957-00D
2	1	Drive Key	146-078634-236
3	2	Crankshaft Kit (includes items 1, 2, 3, & 4)	PE301KB
		Bearing Cone, Tapered Roller	203-168000-999
4	2	Bearing Cup	202-458000-999
5	1	Bearing Carrier, Drive Side	7204-0018-00C
6	2	O-Ring, Nitrile Rubber	110-000271-201
7	12	5/8"NC Hex Head Cap Screw 1-3/4" Long	100-058134-273
8	12	5/8" Lockwasher, Spring Medium	154-058108-244
9	2	Shim Set	7502-0293-00A
10	1	Oil Seal, Drive Side	145-393538-999
11	1	Bearing Carrier, Lube Oil Pump Side Assembly [* Includes item 15, below]	7204-0324-00E
12	1	Gasket	7204-0323-00A

MA-120L-HD, SC-170L, SC-170, SC-170H			
Item	Quantity	Description	Part Number
13	1	Bearing Retainer & Lube Oil Pump Driver Assembly	7204-0322-01B
14	4	1/2"NC x 1" Lg. Socket Hd. Cap Screw, Nyllok	272-012100-999
15	*	Pump Shaft Bushing - One per item 11	7204-0320-00A
16	1	Switchgauge, Murphy	7509-0008-00A
17	1	Lube Oil Pump	7204-0325-00K
18	1	3/8" x 1/8" Hex Pipe Bushing, Hex, Iron	161-038018-451
19	1	1" x 15" Oil Filter	7602-3005-00A
20	1	1-1/4" Oil Filter Plug	7204-0314-00A
21	1	Frame Plug, Drive Side	7204-0315-00A
22	8	5/16"NC x 5/8" Lg. Hex Hd. Cap Screw	100-516058-273
23	1	O-Ring, Nitrile Rubber	110-000210-201
24	2	3/8" Pipe Plug, Socket Hd.	170-038003-237
25	1	O-Ring, Nitrile Rubber	110-00023-201
26	1	Check Valve, Brass	7509-0012-00A

Crankshaft Assembly 4-1/4" Stroke Auburn Gear #8; Right-Hand Drive

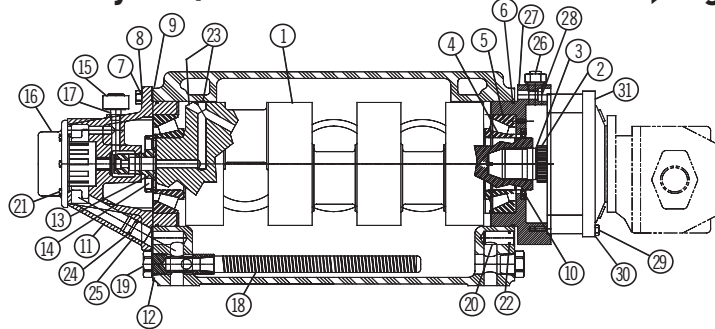

SC-170L, SC-170, SC-170H			
Item	Quantity	Description	Part Number
1	1	Crankshaft Assembly (includes items 1 & 2 & 27)	PE315K
		Crankshaft	7204-1164-00A
2	1	Spline Adapter	7204-1163-00A
3	1	Snap Ring	226-000237-999
4	2	Crankshaft Kit (includes items 1, 2, 27, 3, & 4)	PE315KB
		Bearing Cone, Tapered Roller	203-168000-999
5	2	Bearing Cup	202-458000-999
6	2	O-Ring, Nitrile Rubber	110-000271-201
7	6	5/8"NC Hex Head Cap Screw 1-3/4" Long	100-058134-273
8	6	5/8" Lockwasher, Spring Medium	154-058108-244
9	2	Shim Set	7502-0293-00A
10	1	Oil Seal, Drive Side	145-393538-999
11	1	Bearing Carrier, Lube Oil Pump Side Assembly [* Includes item 15 below]	7204-0324-00E
12	1	Gasket	7204-0323-00A
13	1	Bearing Retainer & Lube Oil Pump Driver Assembly	7204-0322-01B
14	4	1/2"NC x 1" Lg. Socket Hd. Cap Screw, Nyllok	272-012100-999
15	1	Switchgauge, Murphy	7509-0008-00A

SC-170L, SC-170, SC-170H			
Item	Quantity	Description	Part Number
16	1	Lube Oil Pump	7204-0325-00K
17	1	3/8" x 1/8" Hex Pipe Bushing, Hex, Iron	161-038018-451
18	1	1" x 15" Oil Filter	7602-3005-00A
19	1	1-1/4" Oil Filter Plug	7204-0314-00A
20	1	Frame Plug, Drive Side	7204-0315-00A
21	8	5/16"NC x 7/8" Lg. Hex Hd. Cap Screw	100-516078-273
22	1	O-Ring, Nitrile Rubber	110-000210-201
23	2	3/8" Pipe Plug, Socket Hd.	170-038003-237
24	1	O-Ring, Nitrile Rubber	110-00023-201
25	1	Check Valve, Brass	7509-0012-00A
26	1	Breather, Filter	7602-3002-10A
27	1	Bearing Carrier, Gear Adapter	7204-1087-00B
28	6	5/8" Socket Head Cap Screw x 2-1/2" Long	105-058212-454
29	12	3/8" Hex Head Cap Screw x 3-1/4" Long	100-038314-454
30	12	3/8" Washer "Stat-O-Seal"	156-038068-999
31	1	Auburn Gear #8	RTF

Crankshaft Assembly 4-1/4" Stroke Auburn Gear #8; Left-Hand Drive

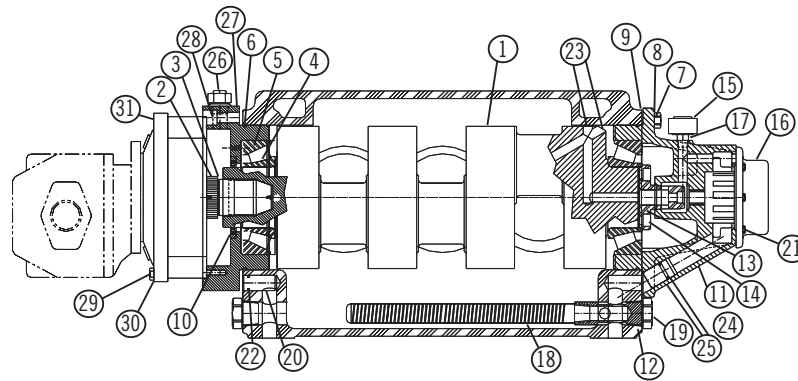

SC-170L, SC-170, SC-170H, SC-170DD			
Item	Quantity	Description	Part Number
		Crankshaft Assembly (includes items 1, 2 & 27)	PE336K
1	1	Crankshaft	7204-1089-00A
2	1	Spline Adapter	7204-1088-00A
3	1	Snap Ring	226-000237-999
		Crankshaft Kit (includes items 1, 2, 3, 4, & 27)	PE336KB
4	2	Bearing Cone, Tapered Roller	203-168000-999
5	2	Bearing Cup	202-458000-999
6	2	O-Ring, Nitrile Rubber	110-000271-201
7	6	5/8"NC Hex Head Cap Screw 1-3/4" Long	100-058134-273
8	6	Lockwasher, Spring, 5/16"	154-516059-244
9	2	Shim Set	7502-0293-00A
10	1	Oil Seal, Drive Side	145-393538-999
11	1	Bearing Carrier, Lube Oil Pump Side Assembly includes Shaft Bushing	7204-0324-00E 7204-0320-00A
12	1	Gasket	7204-0323-00A
13	1	Bearing Retainer & Lube Oil Pump Driver Assembly	7204-0322-00B
14	4	1/2"NC x 1" Lg. Socket Hd. Cap Screw, Nylok	272-012100-999

SC-170L, SC-170, SC-170H, SC-170DD			
Item	Quantity	Description	Part Number
15	1	Switchgauge, Murphy	7509-0008-00A
16	1	Lube Oil Pump	7204-0325-00A
17	1	3/8" x 1/8" Hex Pipe Bushing, Hex, Iron	161-038018-451
18	1	1" x 15" Oil Filter	7602-3005-00A
19	1	1-1/4" Oil Filter Plug	7204-0314-00A
20	1	Frame Plug, Drive Side	7204-0315-00A
21	8	Screw, Cap.; Hex Head, 5/16" - 18UNC x 7/8" Long	100-516078-273
22	1	O-Ring, Nitrile Rubber	110-000210-201
23	2	3/8" Pipe Plug, Socket Hd.	170-038003-237
24	1	O-Ring, Nitrile Rubber	110-000023-201
25	1	Check Valve, Brass	7509-0012-00A
26	1	Breather, Filter	7602-3002-10A
27	1	Bearing Carrier, Gear Adapter	7204-1087-00B
28	6	5/8" Socket Head Cap Screw x 2-1/2"	105-058212-454
29	12	3/8" Hex Head Cap Screw x 3-1/4" Long	100-038314-454
30	12	3/8" Washer "Stat-O-Seal"	156-038068-999
31	1	Auburn Gear #8	RTF

Lube Assembly 4-1/4" Stroke; Right-Hand and Left-Hand Drive; Right-Hand Shown

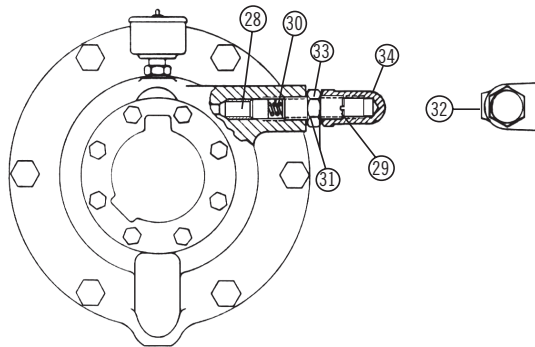

MA-120L, MA120L-HD, MA-120M, SC-170L, SC-170, SC-170H, SC-170DD			
Item	Quantity	Description	Part Number
28	1	Piston, Relief Valve	7204-0318-00A
29	1	Adjusting Screw, Relief Valve	7204-0317-00A
30	1	Spring, Relief Valve	7204-0319-00A
31	2	Washer	204-013009-206

MA-120L, MA-120L-HD, MA-120M, SC-170L, SC-170, SC-170H, SC-170DD			
Item	Quantity	Description	Part Number
32	1	1/8" Pipe Plug, Socket Hd.	170-018003-235
33	1	7/8" x 14" Thread Jam Nut, Hex	130-078014-243
34	1	Cap, Relief Valve	7204-0316-00A

Fluid End Assembly (Ductile Iron)

MA-95L, MA-120L-HD, SC-170L			
Item	Quantity	Description	Part Number
1	3	Valve Cover Screw, Ductile Iron	7204-0345-00B
2	3	Valve Cover, Steel	7204-0403-10B
3	3	O-Ring, Nitrile Rubber	001500131
4	4	1/4" Hex Hd. Pipe Plug, S.S.	170-014002-405
5	1	Liquid End, Ductile Iron, for Tapered Seats	7204-0405-00E
6	12	1" x 4-7/8" Stuffing Box Stud	7507-2791-00A
7	28	1"-8NC Nut, Heavy Hex	133-100008-243
8	16	1" x 4-1/8" Stud, Discharge Flange	7507-2794-00A
9	16	3/4" x 3" Stud, Suction Flange	7507-2735-00A
10	16	3/4"-10NC Nut, Heavy Hex	133-034010-243
11	3	1/2" Hex Hd. Pipe Plug	170-012002-237
12	2	Stud, Power Frame to Fluid End*	7204-0865-00A
13	2	1-1/4"-7NC Nut, Heavy Hex*	133-114007-243
14	2	Suction Flange Gasket* 7-3/4" x 5"	204-077050-206
15	2	Discharge Flange Gasket* 4-1/8" x 2-1/2"	204-041025-206

*Not shown on Parts List Drawing

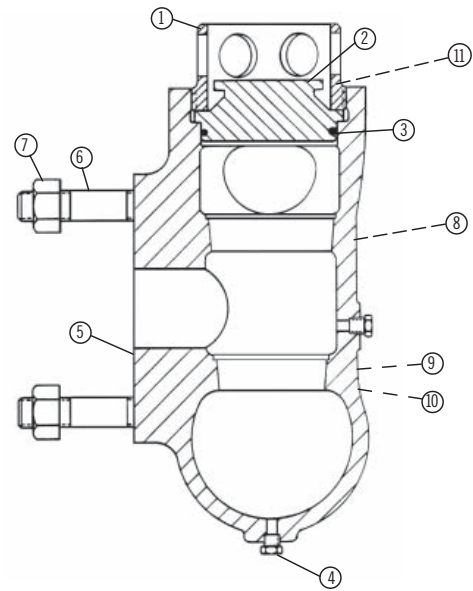

Fluid End Assembly (Nickel Aluminum Bronze)

MA-95L, MA-120L-HD, SC-170L			
Item	Quantity	Description	Part Number
1	3	Valve Cover	7204-0058-00B
2	3	Valve Cover Seal	7204-0061-00A
3	1	3/4" Hex Hd. Pipe Plug, S.S.	170-034002-405
4	1	Liquid End, Nickel Aluminum Bronze	7204-0057-10E
5	12	1" x 4-7/8" Stuffing Box Stud	7507-2791-00A
6	16	1" x 4-1/8" Stud, Discharge Flange*	7507-2794-00A
7	12	1" x 3-5/16" Valve Cover Stud	7507-2793-00A
8	40	1"-8NC Nut, Heavy Hex	133-100008-243
9	16	3/4" x 3" Stud, Suction Flange*	7507-2735-00A
10	16	3/4"-10NC Nut, Heavy Hex*	133-034010-243
11	2	1/2" Hex Hd. Pipe Plug, S.S.*	170-012002-405
12	2	Stud, Power Frame to Fluid End*	7204-0865-00A
13	2	1-1/4"-7NC Nut, Heavy Hex*	133-114007-243

*Not shown on Parts List Drawing

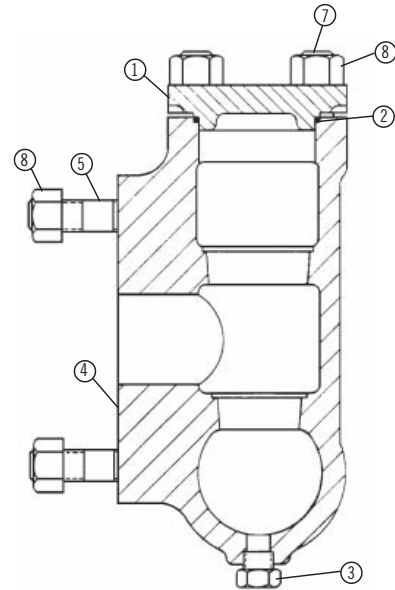

Fluid End Assembly (Ductile Iron)

SC-170DD			
Item	Quantity	Description	Part Number
1	6	Valve Cover Screw, Ductile Iron	7204-0601-00B
2	6	Valve Cover, S. Steel	7204-1234-00B
3	6	Fluid Seal	7204-1235-10A
4	2	3/8" Hex Hd. Pipe Plug*	170-038001-237
5	1	Liquid End, Ductile Iron	7204-1196-00D
6	12	1" x 6-1/8" Liner Stud	7204-1143-00A
7	12	1"-8NC Nut, Heavy Hex	127-100008-243
8	32	3/4" Stud, Flange	7507-2735-00A
9	32	3/4"-10NC Nut, Heavy Hex	133-034010-243
10	2	Stud, Power Frame to Fluid End	7204-1227-00A
11	2	1-1/4"-7NC Nut, Heavy Hex	133-114007-243
12	3	Seal Ring	7204-1237-00A
13	3	O-Ring, #252	110-000252-201
14	3	Pipe Plug, 3/4"	170-037002-237

*Not shown on Parts List Drawing

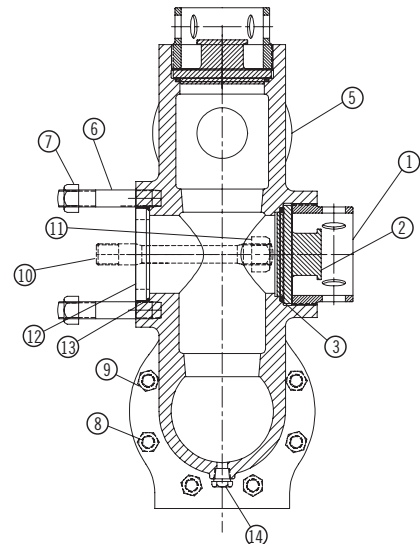

Fluid End Assembly (Steel Block Weld-Neck Flanges)

MA-95L, MA-120L-HD			
Item	Quantity	Description	Part Number
1	3	Valve Cover Screw, Ductile Iron	7204-0345-00B
2	3	Valve Cover, Steel	7204-0403-10B
3	3	O-Ring, Nitrile Rubber	110-000243-201
4	4	1/4" Hex Hd. Pipe Plug, S.S. (optional)	170-014002-405
5	1	Liquid End, Forged Steel Weldment	7204-0861-00E
6	12	1" x 4-7/8" Stuffing Box Stud	7507-2791-00A
7	12	1"-8NC Nut, Heavy Hex	133-100008-243
8	2	Stud, Power Frame to Liquid End	7204-0865-00A
9	2	1-1/4"-7NC Nut, Heavy Hex	133-114007-243

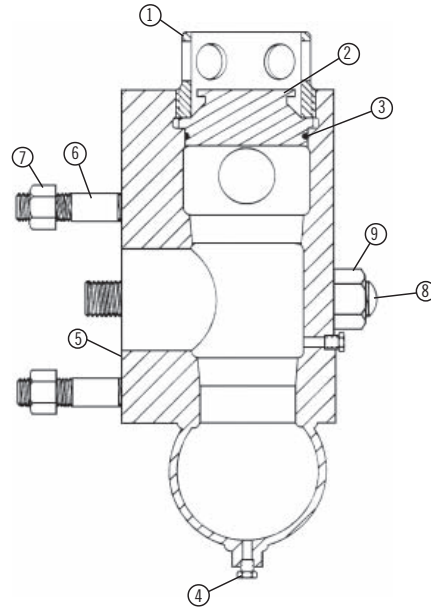

Fluid End Assembly (Nickel Aluminum Bronze Block)

MA-95M, MA-120M			
Item	Quantity	Description	Part Number
1	3	Valve Cover, Aluminum Bronze	7204-0059-00B
2	3	Valve Cover Gasket	7204-0060-00A
3	12	1" x 3-5/16" Stud, Valve Cover	7507-2793-00A
4	24	1"-8 Thread Nut, Hvy. Hex	133-100008-243
5	12	1" x 4-7/8" Stud, Stuffing Box	7507-2791-00A
6	16	7/8" x 3-7/8" Stud, Discharge Flange	7507-2736-00A
7	16	7/8"-9 Thread Nut, Hvy. Hex	133-078009-243
8	8	5/8" x 2-3/4" Stud, Suction Flange	7507-2732-00A
9	8	5/8"-11 Thread Nut, Hvy. Hex	133-058011-243
10	1	Liquid End	7204-0013-00E
11	3	3/4" Hex Head Pipe Plug, Stainless Steel	170-034002-405
12	2	1/2" Hex Head Pipe Plug, Stainless Steel*	170-012002-405
13	2	Stud, Power Frame to Liquid End*	7204-0865-00A
14	2	1-1/4"-7 Thread Nut, Heavy Hex*	133-114007-243

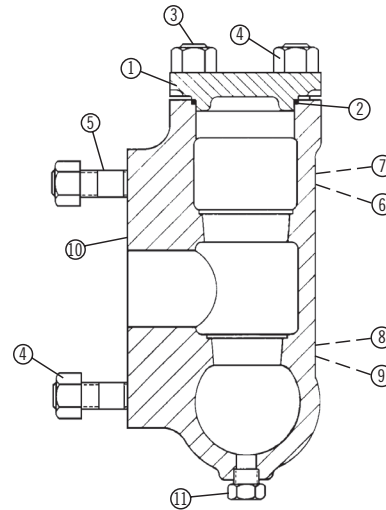

* Note: Not shown on Parts List Drawing

Fluid End Assembly (Steel Block)

MA-95M, MA-120M, SC-170H			
Item	Quantity	Description	Part Number
1	3	Valve Cover, Steel	7202-0304-00B
2	3	Valve Cover Gasket	7202-0041-01A
3	12	1" x 4-7/8" Stud, Stuffing Box	7507-2791-00A
4	12	1"-8 Thread Nut, Hvy. Hex	133-100008-243
5	1	Liquid End*	7204-0875-00E
6	1	1/4" Steel Hex Head Pipe Plug	170-014002-237
7	2	Stud, Power Frame to Liquid End	7204-0865-00A
8	2	1-1/4"-7 Thread Nut, Heavy Hex	133-114007-243

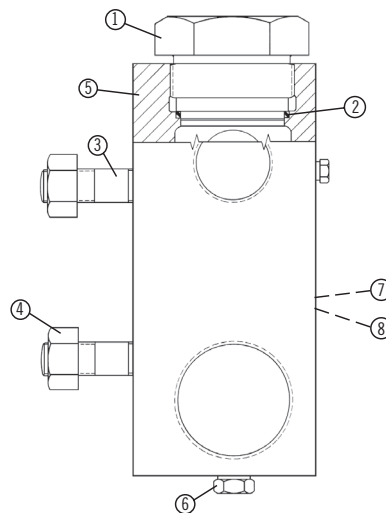

* Note: Liquid End has integral suction and discharged ring-joint faced connections, as follows:
Suction 3" - 600#RTJ; Discharged 2" - 600#RTJ

Fluid End Assembly (Steel Block Weld-Neck Flanges)

MA-120L			
Item	Quantity	Description	Part Number
1	3	Valve Cover Screw, Ductile Iron	7204-0345-00B
2	3	Valve Cover, Steel	7204-0403-10B
3	3	O-Ring, Nitrile Rubber	001500131
4	4	1/4" Hex Hd. Pipe Plug, S.S. (Optional)	170-014002-405
5	1	Liquid End, Forged Steel Weldment	7204-1239-00E
6	12	1" x 4-7/8" Stuffing Box Stud	7507-2791-00A
7	12	1"-8NC Nut, Heavy Hex	133-100008-243
8	2	Stud, Power Frame to Liquid End	7204-0865-00A
9	2	1-1/4"-7NC Nut, Heavy Hex	133-114007-243

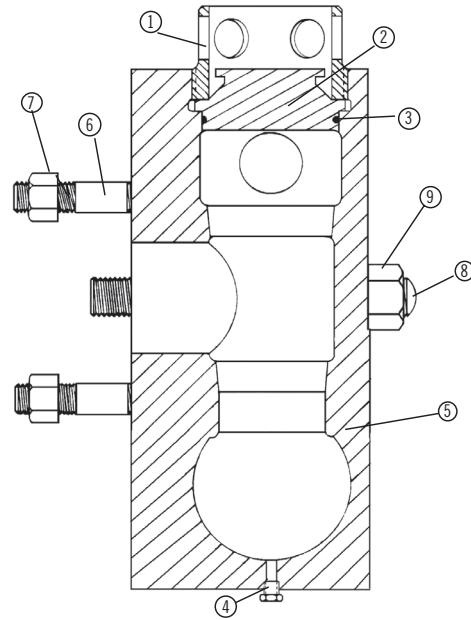

Fluid End Assembly (Steel Block)

SC-170L			
Item	Quantity	Description	Part Number
1	3	Valve Cover Screw, Steel	7204-0403-00B
2	3	Valve Cover Screw	7204-0345-00B
3	3	O-Ring	110-000243-201
4	12	1" x 4-7/8" Stuffing Box Stud	7507-2791-00A
5	12	1"-8 Thread Nut, Hvy. Hex	133-100008-243
6	1	Liquid End, Forged Steel Weldment	7204-0861-02E
7	4	1/4" Steel Hex Head Pipe Plug (Optional)	170-014002-237
8	2	Stud, Power Frame to Liquid End	7204-0865-00A
9	2	1-1/4"-7 Thread Nut, Heavy Hex	133-114007-243

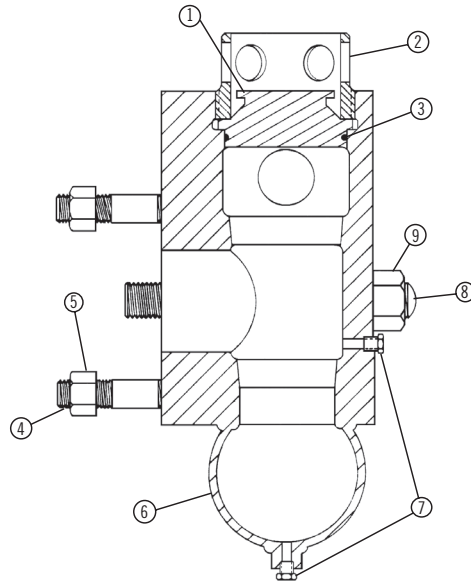

Fluid End Assembly (Steel Block)

SC-170			
Item	Quantity	Description	Part Number
1	3	Valve Cover, Steel	7201-0087-10B
2	3	Valve Cover Gasket	7201-0081-00A
3	12	Stud, Valve Cover	7507-2793-00A
4	12	1"-8UN Nut, Hvy. Hex	133-100008-243
5	1	Liquid End	7204-0952-00K
6	6	Pipe Plug	170-014002-237
7	12	Stuffing Box Stud	7507-2791-00A
8	12	1"-8NC Nut, Heavy Hex	133-100008-243
9	2	Stud, Power Frame to Liquid End	7204-0865-00A
10	2	1-1/4"-7NC Nut, Heavy Hex	133-114007-243

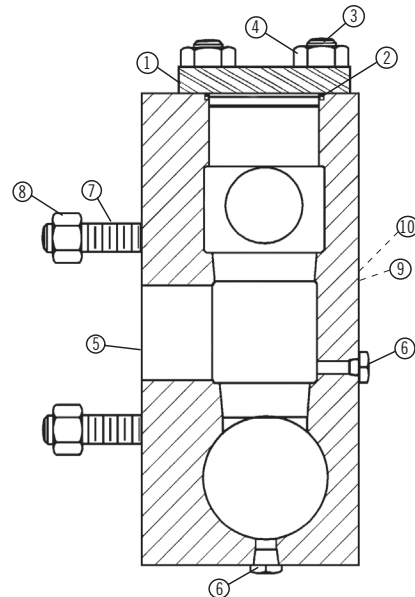

Stuffing Box Assembly

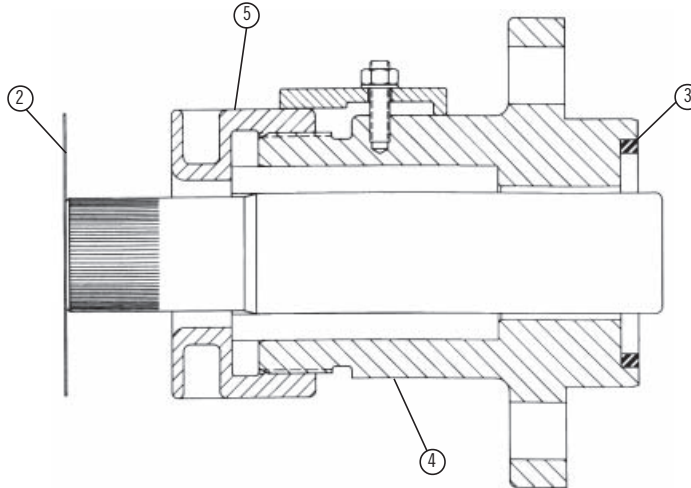

Qty. 3 per pump ea.

MA-95L, MA-120L-HD, SC-170L, SC-170							
Plunger Diameter	Baffle (#2)	Stuffing Box Seal, Nitrile Rubber (#3)	Stuffing Box, *Steel (#4)	Stuffing Box, Stainless Steel (#4)	Stuffing Box, Nickel Alum. Bronze (#4)	Gland, *Steel (#5)	Gland, Nickel Alum. Bronze (#5)
3-1/2"	7204-0016-00A	7204-0054-00A	7204-0385-00B	7204-0385-10B	7204-0012-10B	7204-0377-00B	7204-0052-00B
3-3/8"	7204-0016-00A	7204-0054-00A	7204-0385-00B	7204-0385-10B	7204-0012-10B	7204-0377-00B	7204-0052-00B
3-1/4"	7204-0016-00A	7204-0054-00A	7204-0385-00B	7204-0385-10B	7204-0012-10B	7204-0377-00B	7204-0052-00B
3-1/8"	7204-0016-00A	7204-0054-00A	7204-0384-00B	7204-0384-10B	7204-0011-10B	7204-0376-00B	7204-0051-00B
3"	7204-0016-00A	7204-0054-00A	7204-0384-00B	7204-0384-10B	7204-0011-10B	7204-0376-00B	7204-0051-00B
2-7/8"	7204-0016-00A	7204-0054-00A	7204-0384-00B	7204-0384-10B	7204-0011-10B	7204-0376-00B	7204-0051-00B
2-3/4"	7204-0016-00A	7204-0054-00A	7204-0384-00B	7204-0383-10B	7204-0011-10B	7204-0376-00B	7204-0051-00B
2-5/8"	7204-0016-00A	7204-0054-00A	7204-0384-00B	7204-0383-10B	7204-0011-10B	7204-0376-00B	7204-0051-00B
2-1/2"	7204-0016-00A	7204-0054-00A	7204-0383-00B	7204-0383-10B	7204-0010-10B	7204-0375-00B	7204-0049-00B
2-3/8"	7204-0016-00A	7204-0054-00A	7204-0383-00B	7204-0383-10B	7204-0010-10B	7204-0375-00B	7204-0049-00B

*GLAND NUT WRENCH 7204-0464-00B

Stuffing Box Assembly

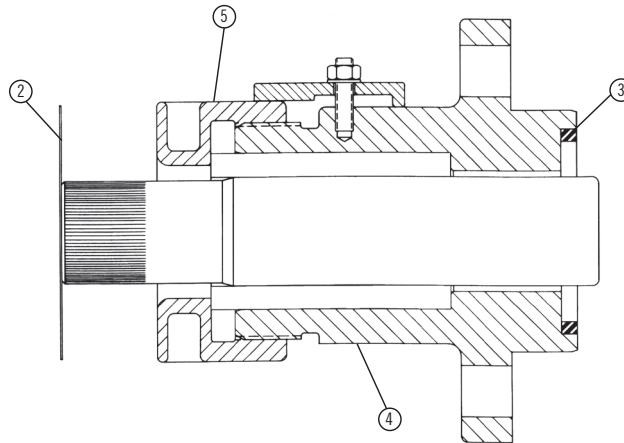

Qty. 3 per pump ea.

MA-95M, MA-120M, SC-170H						
Plunger Diameter	Baffle (#2)	Stuffing Box Seal, Nitrile Rubber (#3)	Stuffing Box *Steel (#4)	Stuffing Box *Nickel Alum. Bronze (#4)	Gland *Steel (#5)	Gland *Nickel Alum. Bronze (#5)
2-3/8"	7204-0016-00A	7204-0054-00A	7204-0383-00B	7204-0010-10B	7204-0375-00B	7204-0049-00B
2-1/4"	7204-0016-00A	7204-0054-00A	7204-0383-00B	7204-0010-10C	7204-0375-00B	7204-0049-00B
2-1/8"	7204-0016-00A	7204-0054-00A	7204-0383-00B	7204-0010-10C	7204-0375-00B	7204-0049-00B
2"	7204-0016-00A	7204-0053-00A	7204-0340-00C	7204-0009-10C	7204-0342-00B	7204-0048-00B
1-7/8"	7204-0016-00A	7204-0053-00A	7204-0340-00C	7204-0009-10C	7204-0342-00B	7204-0048-00B
1-3/4"	7204-0016-00A	7204-0053-00A	7204-0340-00C	7204-0009-10C	7204-0342-00B	7204-0048-00B
1-5/8"	7204-0016-00A	7202-0012-00A	7204-0339-00C	7204-0008-10B	7204-0341-00B	7204-0047-00B
1-1/2"	7204-0016-00A	7202-0012-00A	7204-0339-00C	7204-0008-10B	7204-0341-00B	7204-0047-00B

*GLAND NUT WRENCH 7204-0464-00B

Stuffing Box Assembly

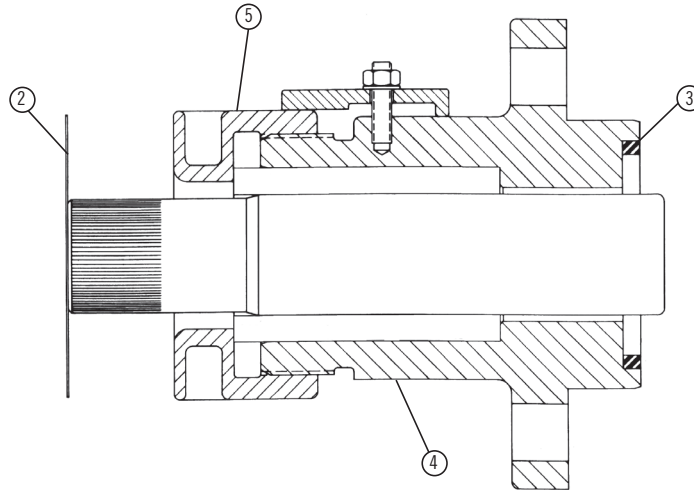

Qty. 3 per pump ea.

MA-120L				
Plunger Diameter	Baffle (#2)	Stuffing Box Seal, Nitrile Rubber (#3)	Stuffing Box, Steel (#4)	Gland Nut, Steel (#5)
2-3/8"	7204-0016-00A	7204-0054-00A	7204-1305-02B	7204-0375-00B

GLAND NUT WRENCH 7204-0464-00B

4" Piston Assembly

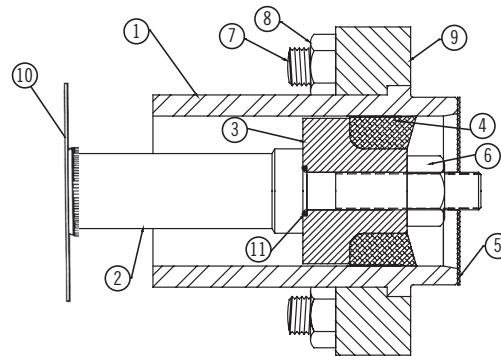

Qty. 3 per pump ea.

SC-170L, SC-170DD			
Item	Quantity	Description	Part Number
1	1	Piston Liner, 4" High Chrome Iron	7204-1106-00K
2	1	Piston Rod	7204-1056-00B
3	1	Piston Assembly (Black) Part of #3 Above	7204-1146-00K
5	1	Gasket, Liner	316-049042-508
6	1	Nut, Piston Rod, Self Locking	151-100008-273

SC-170L, SC-170DD			
Item	Quantity	Description	Part Number
7	4	Stud (included in FE350)	7204-1143-00A
8	4	Nut, 1"NC (included in FE350)	127-100008-243
9	1	Piston Liner Flange	7204-1054-00B
10	1	Baffle	7204-0016-00A
11	1	O-Ring, Furnished with item #3	110-000214-201

4-1/4" Piston Assembly

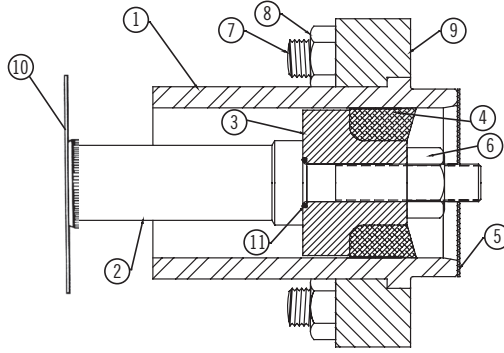

Qty. 3 per pump

SC-170DD			
Item	Quantity	Description	Part Number
1	1	Piston Liner, 4-1/4" White Ceramic	7204-1265-00K
2	1	Piston Rod	7204-1056-00B
3	1	Piston Assembly (Black)	7204-1057-00K
4		Part of #3 Above	
5	1	Gasket, Liner	316-049042-508
6	1	Nut, Piston Rod, Self Locking	151-100008-273

SC-170DD			
Item	Quantity	Description	Part Number
7	4	Stud	7204-1143-00A
8	4	Nut, 1"NC	127-100008-243
9	1	Piston Liner Flange	7204-1054-00B
10	1	Baffle	7204-0016-00A
11	1	O-Ring, Furnished with item #3	110-000214-201

4-1/2" Piston Assembly

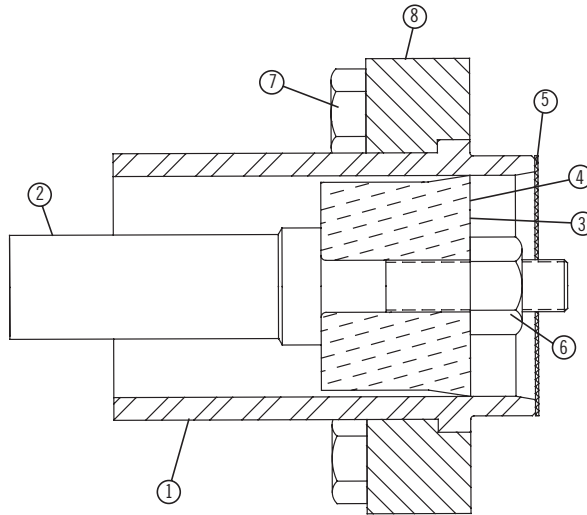

Qty. 5 per pump

SC-170DD			
Item	Quantity	Description	Part Number
1	1	Piston Liner	7204-1108-00K
2	1	Piston Rod	7204-1056-00B
3	1	Piston Cup Assembly, 4-1/2"	7201-0731-00K
4		Piston Rubber, Furnished with Above	7201-0732-00A

SC-170DD			
Item	Quantity	Description	Part Number
5	1	Gasket, Liner	204-049046-206
6	1	Nut, Piston Rod, Self Locking	151-100008-273
7	4	1"-BNC x 4-1/2" Long 12 Point Screw	100-100008-999
8	1	Piston Liner Flange	7204-1054-00B

THIS PAGE INTENTIONALLY LEFT BLANK

STANDARD LIMITED WARRANTY CENTRIFUGAL & RECIPROCATING PUMPS

Pentair Myers® warrants its products against defects in material and workmanship for a period of 12 months from the date of shipment from Pentair Myers or 18 months from the manufacturing date, whichever occurs first – provided that such products are used in compliance with the requirements of the Pentair Myers catalog and technical manuals.

During the warranty period and subject to the conditions set forth, Pentair Myers, at its discretion, will repair or replace to the original user, the parts that prove defective in materials and workmanship. Pentair Myers reserves the right to change or improve its products or any portions thereof without being obligated to provide such a change or improvement for prior sold and/or shipped units.

Seals, piston cups, packing, plungers, liners and valves used for handling clear, fresh, nonaerated water at a temperature not exceeding 120°F are warranted for ninety days from date of shipment. All other applications are subject to a thirty day warranty. Accessories such as motors, engines and auxiliary equipment are warranted by the respective manufacturer and are excluded in this standard warranty. Under no circumstance will Pentair Myers be responsible for the cost of field labor, travel expenses, rented equipment, removal/reinstallation costs or freight expenses to and from the factory or an authorized Pentair Myers service facility.

This limited warranty will not apply: (a) to defects or malfunctions resulting from failure to properly install, operate or maintain the unit in accordance with the printed instructions provided; (b) to failures resulting from abuse, accident or negligence; (c) to normal maintenance services and parts used in connection with such service; (d) to units that are not installed in accordance with applicable local codes, ordinances and good trade practices; (e) if the unit is moved from its original installation location; (f) if unit is used for purposes other than for what it is designed and manufactured; (g) to any unit that has been repaired or altered by anyone other than Pentair Myers or an authorized Pentair Myers service provider; (h) to any unit that has been repaired using non factory specified/OEM parts.

Warranty Exclusions: PENTAIR MYERS MAKES NO EXPRESS OR IMPLIED WARRANTIES THAT EXTEND BEYOND THE DESCRIPTION ON THE FACE HEREOF. PENTAIR MYERS SPECIFICALLY DISCLAIMS THE IMPLIED WARRANTIES OF MERCHANTABILITY AND FITNESS FOR ANY PARTICULAR PURPOSE.

Liability Limitation: IN NO EVENT SHALL PENTAIR MYERS BE LIABLE OR RESPONSIBLE FOR CONSEQUENTIAL, INCIDENTAL OR SPECIAL DAMAGES RESULTING FROM OR RELATED IN ANY MANNER TO ANY PENTAIR MYERS PRODUCT OR PARTS THEREOF. PERSONAL INJURY AND/OR PROPERTY DAMAGE MAY RESULT FROM IMPROPER INSTALLATION. PENTAIR MYERS DISCLAIMS ALL LIABILITY, INCLUDING LIABILITY UNDER THIS WARRANTY, FOR IMPROPER INSTALLATION. PENTAIR MYERS RECOMMENDS INSTALLATION BY PROFESSIONALS.

Some states do not permit some or all of the above warranty limitations or the exclusion or limitation of incidental or consequential damages and therefore such limitations may not apply to you. No warranties or representations at any time made by any representatives of Pentair Myers shall vary or expand the provision hereof.



MYERS® APLEX SERIES

1101 MYERS PARKWAY
ASHLAND, OHIO, USA 44805
419-289-1144

WWW.FEMYERS.COM

Warranty Rev. 12/13