

BATTERY BACKUP SUMP PUMP SYSTEM

MBSP-PLUS MODEL

The Myers MBSP-Plus Battery Backup Sump Pump System operates automatically in case of pump or power failure. This high-capacity system can pump up to 47 GPM and performs comparably with 1/3 HP primary pumps. Features a computerized monitoring, control, and alarm system.

APPLICATIONS

Emergency dewatering.

FEATURES

- ◆ **Protects Home:** If AC-powered pump fails. Backs up residential sump pump automatically during power outage or pump failure.
- ◆ **Meets High Demand:** Effortlessly handles active sump pits with large-capacity system
- ◆ **Powerful Charge:** Full 8A multi-stage charging system with steel enclosure provides the strongest battery charge
- ◆ **Quick Connect Power:** Plug-in style connectors for quick, easy installation
- ◆ **Two Way System Status:** Audio and visual alarms keep you informed of system status at all times
- ◆ **A Good Fit:** Fits most new and existing sump pits
- ◆ **System Components:** Includes pump with built-in check valve, float switch, tee, battery box, charger and control center (battery not included*)

SPECIFICATIONS

- ◆ **Liquids Handling:** Sump drain water
- ◆ **Capacities:** Up to 30 GPM (114 LPM)
- ◆ **Shut-off Head:** To 16 ft. (4.88 m)
- ◆ **Housing and Impeller:** Thermoplastic
- ◆ **Intermittent Liquid Temperature:** Up to 77°F (25°C)
- ◆ **Motor/Electrical Data:** 12V, DC, 18A at 10 ft. (3M) lift
- ◆ **Charger:** Fully automatic, computerized monitoring, control and alarm system; input: 115V AC, 60Hz; output: 12V AC, 8A (5 stages)
- ◆ **Battery Requirement*:** 12V, deep cycle, marine-type (Group 24), minimum 75-120 AH
- ◆ **Pump Discharge:** 1.25" NPT (31.75 mm)
- ◆ **Pump Down Range:** Variable with float setting
- ◆ **Check Valve:** Dual check valves
- ◆ **Capacities:** 47 GPM (178 LPM) , Heads: To 18 ft. (5.49 m)
- ◆ **Check Valve:** Included



ORDERING INFORMATION

CATALOG NUMBER	VOLTS	CYCLES	CORD LENGTH	APPROX. WT. LBS
MBSP-PLUS-18T	12 DC	60	8'	22

*Deep cycle marine-type battery (Group 24) recommended – not included with MBSP system.

BATTERY BACKUP SUMP PUMP SYSTEM MBSP-PLUS MODEL

PUMP PERFORMANCE

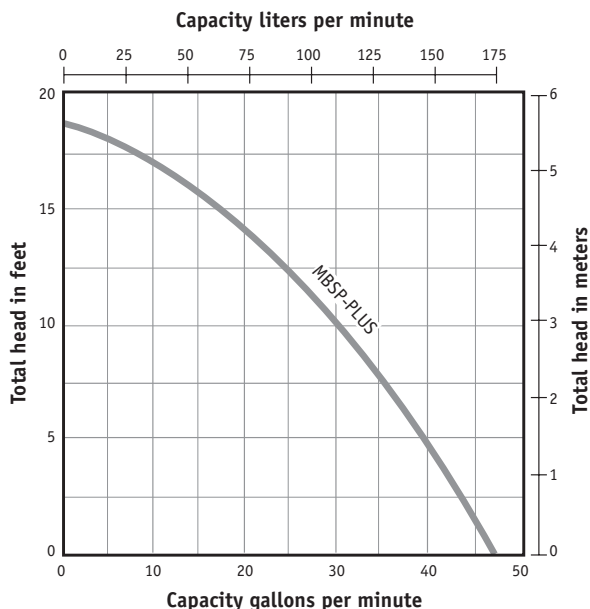

DIMENSIONS

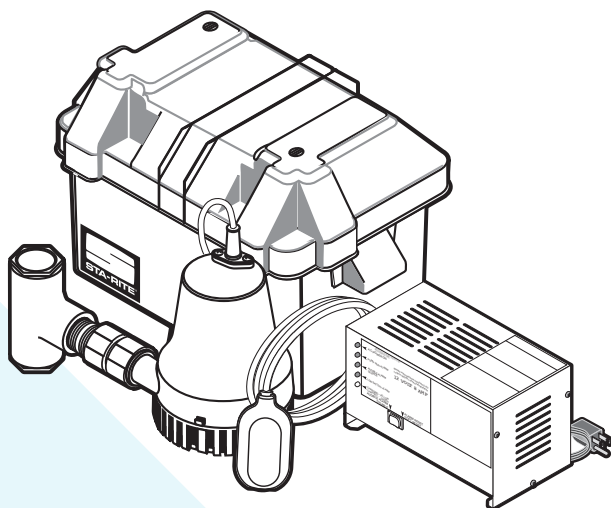

293 Wright St
Delavan, WI 53115
Ph: 888.987.8677
Fx: 800.426.9446

490 Pinebush Rd., Unit 4
Cambridge, Ontario N1T 0A5, Canada
Ph: 800.363.7867
Fx: 888.606.5484

pentair.com

All indicated Pentair trademarks and logos are property of Pentair. Third party registered and unregistered trademarks and logos are the property of their respective owners. Because we are continuously improving our products and services, Pentair reserves the right to change specifications without prior notice. Pentair is an equal opportunity employer.

©2023 Pentair. All Rights Reserved.

M9020SSE (03-15-23)