

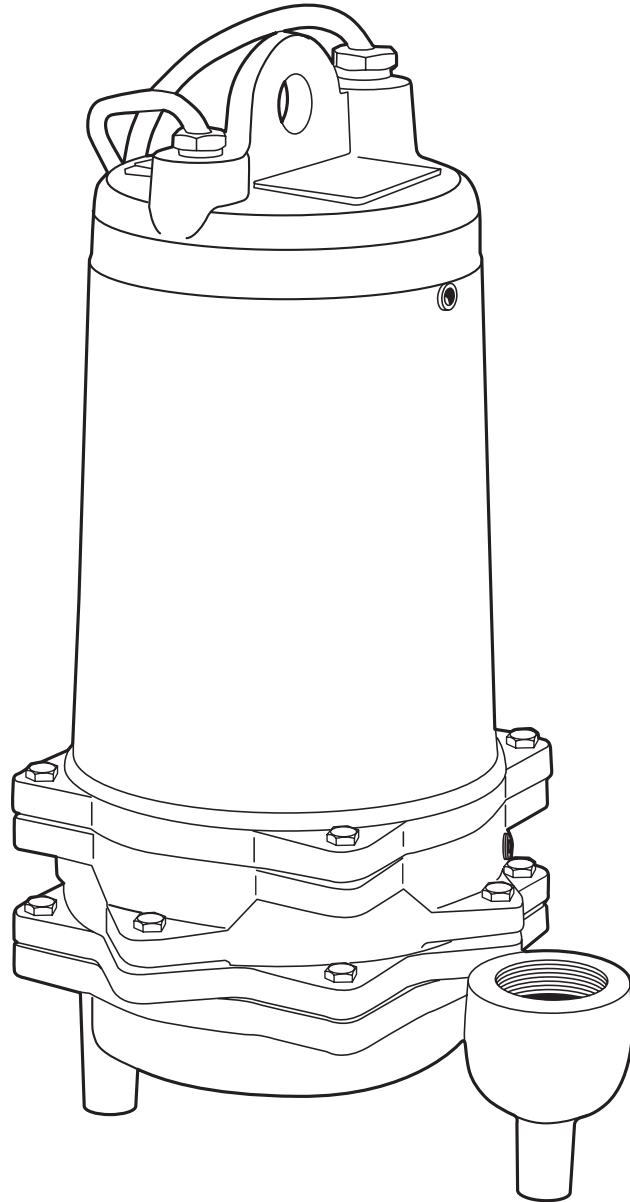

MYERS®



P51, P52 and P102 SERIES **SUBMERSIBLE SUMP AND EFFLUENT S.T.E.P. PUMPS**

INSTALLATION AND SERVICE MANUAL

**For double seal units with or without seal leak detectors.
Single phase power only.**

NOTE! To the installer: Please make sure you provide this manual to the owner of the equipment or to the responsible party who maintains the system.

NOTE: READ THESE INSTRUCTIONS CAREFULLY BEFORE ATTEMPTING TO INSTALL PUMP.

DESCRIPTION AND APPLICATION

Myers "P" Series Pumps are double seal units designed for use in Septic Tank Effluent Pumping (S.T.E.P.) or normal sump and general dewatering applications where higher pressure is required. **DO NOT USE FOR RAW SEWAGE.**

When used in S.T.E.P. applications, the pump must be installed in a separate tank or compartment at the discharge side of the septic tank. **NEVER INSTALL PUMP IN MAIN TANK WHERE SLUDGE COLLECTS.**

These pumps are available in single phase only as 1/2 HP - 115V, 1/2 HP - 230 V, and 1 HP - 230 V, either with seal leak detectors (P51D) or without seal leak detectors (P51). All units with seal leak detectors and all duplex installations must be used with a control box. All power cords (14/3) and seal leak detector cords (16/2) are 20 feet long. All units without seal leak detectors have grounded plugs on the power cord.

Impellers are enclosed single vane type to handle 3/4" spherical solids and are available made of engineered thermoplastic or cast brass. All pumps have a 1-1/2" NPT discharge tapping.

WARNING! THESE PUMPS ARE NOT APPROVED FOR, AND SHOULD NOT BE USED IN, SWIMMING POOLS OR FOUNTAINS.

AIR LOCKING

A sump pump is said to be air locked if water traps air in the pump and it cannot get out, thus preventing the pump from operating.

In installations of this type a 1/8" hole should be drilled in the discharge pipe below the check valve. The check valve should be 12 to 18 inches above pump discharge. Do not put check valve directly into pump discharge opening.

LEVEL CONTROLS

All pumps must use sealed level control switches for automatic operation. MLC and MFLC controls have sealed switches that are 1 HP rated at 230 volts.

Simplex single phase pumps can be made automatic by attaching MFLC or MLC controls to the pump. These switches have a fixed draw off level of 8 to 10" and can be used up to 1 HP. Simplex systems may also use on/off pilot mercury* control switches with control box and magnetic starter. All duplex systems

must use pilot mercury* control switches with control box and magnetic starters.

Plug-in cords can be used on all the single phase pumps without seal leak detector. This cord has a GROUND pin that plugs into a grounded receptacle. The grounded receptacle cannot be used in the wet sump or basin due to DANGER of current leakage.

Sealed junction boxes must be used in wet sumps or basins to make connections to motor cord. The AWS-1 control also acts as a sealed junction box for connecting power cord to pump cord.

DOUBLE SEAL PUMPS

All pumps in this series have two seals with an oil chamber in between the seals so that the seal faces of both the lower and upper seals are oil lubricated for longer life and greater protection against water leaking into the motor windings. These double seal units are made with and without a seal leak detector.

The leak detector in the oil seal chamber detects any water leakage into the chamber and turns on a red signal light in the control panel. Pumps should be removed from the sump and seals replaced after the seal light shows in the panel. Control panels must be used for pumps having seal leak detectors and seal leak detectors must be wired as illustrated in this instruction manual.

MOTOR TYPE

Motors are 3/4 frame, 1/2 and 1 HP single phase, 60 Hertz, 3450 RPM, permanent split-capacitor (PSC) type with built-in on winding overload protection and has Class B insulation. Motor does not require a start switch or start relay. It has upper and lower ball bearings and is cooled and lubricated.

SAFETY WARNINGS

WARNING: Risk of electrical shock. Pumps without seal leak detectors are supplied with grounding conduction and grounding-type attachment plug on the power cord. To reduce the risk of electric shock, be certain that it is connected only to a properly grounded, grounding-type receptacle. DO NOT cut off ground pin or use an adapter fitting. DO NOT use an extension cord with this pump. Entire plug may be cut off if a control panel is used.

When wiring this pump follow all local electrical and safety codes and ordinances as well as the most recent National Electric Code (NEC-ANSI/NFPA 70).

All pumps have a GROUND WIRE that is connected to a screw in the metal motor housing. This wire

*This product contains mercury and must be disposed of according to local and federal codes.

goes to the receptacle or control box which must be connected to a good outside GROUND such as a metal water pipe or GROUND STAKE driven at least 8 feet into the ground.

CALIFORNIA PROPOSITION 65 WARNING:

▲ WARNING This product and related accessories contain chemicals known to the State of California to cause cancer, birth defects or other reproductive harm.

INSTALLATION

WARNING: Basin or tank must be vented in accordance with local plumbing codes. These pumps are not designed for and CANNOT be installed in locations classified as hazardous in accordance with the National Electric Code ANSI/NFPA 70.

CAUTION: Never enter pump chamber after sewage or effluent has been in basin. Sewage water can give off methane, hydrogen sulfide and other gases which are highly poisonous.

For this reason, Myers recommends installing the P series effluent pumps with a quick removal system. The quick removal system may be a union or Cam-lok® coupling if the piping or discharge hose is within reach from the surface or a rail system type quick disconnect on deeper installations. See installation drawings for suggested installation.

The dosing tank or pumping chamber must be constructed of corrosion resistant materials and must be capable of withstanding all anticipated internal and external loads. It also must not allow infiltration or exfiltration. The tank must have provisions for anti buoyancy. Access holes or covers must be of adequate size and be accessible from the surface to allow for installation and maintenance of the system. Access covers must be lockable or heavy enough to prevent easy access by unauthorized personnel. The pumping chamber holding capacity should be selected to allow for emergency conditions.

The discharge pipe must be the same size as the pump discharge (1-1/2") or larger. In order to ensure sufficient fluid velocity to prevent any residual solids from collecting in the discharge pipe, it is recommended that a minimum flow of 2 feet per second be maintained. (12 GPM through 1-1/2" pipe, 21 GPM through 2" pipe and 46 GPM through 3" pipe). It is recommended that PVC or equal pipe ID used for corrosion resistance.

A full flow (ball or gate) shut-off valve must be installed to prevent backflow of effluent if the pump must be removed for service. A check valve must be installed on pressure sewer systems and on other systems where conditions allow to prevent backflow and to reduce wear on the pump system.

A high water alarm must be installed on a separate circuit from the pump circuit. The alarm should have the ability to be tested for proper operation.

POINTS TO CHECK IF PUMP DOES NOT RUN OR DOES NOT RUN PROPERLY

1. Pump does not run or start when water is up in tank.

- a. Check for blown fuse or tripped circuit breaker.
- b. Check for defective level switch.
- c. Where control panel is used be sure H-O-A switch is in the AUTO position. If it does not run, turn switch to the HAND position and if the pump runs, the trouble is in the automatic electrical system. Have ELECTRICIAN make electrical checks.
- d. Check for burned-out motor. Occasionally lightning can damage a motor even with lightning protection.
- e. Where plug-in cords are used, be sure contact blades are clean and making good contact. **DO NOT USE PLUG-IN CORDS INSIDE A SUMP OR WET WELL.**

2. Pump runs but does not deliver flow.

- a. Check for air lock. Start and stop pump several times. If this does not help it may be necessary to loosen a union in the discharge line to relieve air lock.
- b. Check valve may be installed backward. Check flow arrow on valve body. Check shut-off valve. It may be closed.
- c. Check vertical elevation. It may be higher than pump can develop.
- d. Pump inlet may be plugged. Remove pump to check.
- e. Level control ball or weight may be stuck on side of basin. Be sure it floats freely.

CAUTION: ALWAYS UNPLUG POWER CORDS OR TURN OFF ALL MAIN AND BRANCH CIRCUIT BREAKERS BEFORE DOING ANY WORK ON THE PUMP. If control panel is remote from pump, disconnect lead wires to motor so that no one can turn the circuit breaker back on.

TYPICAL SECTIONAL DRAWING FOR P SERIES DOUBLE SEAL PUMP

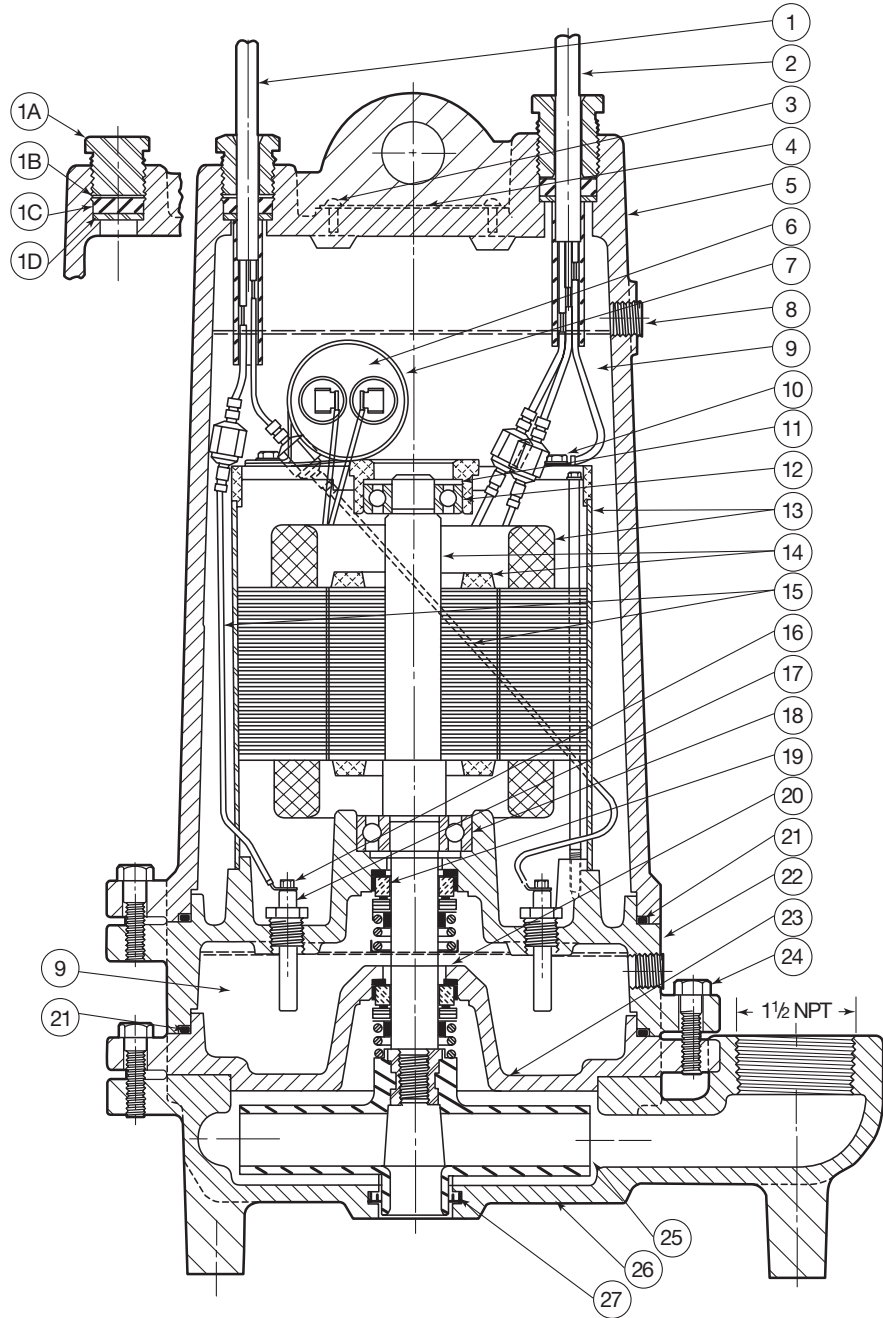

P SERIES DIMENSIONS

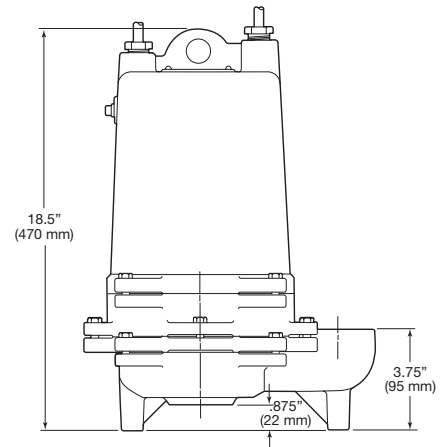
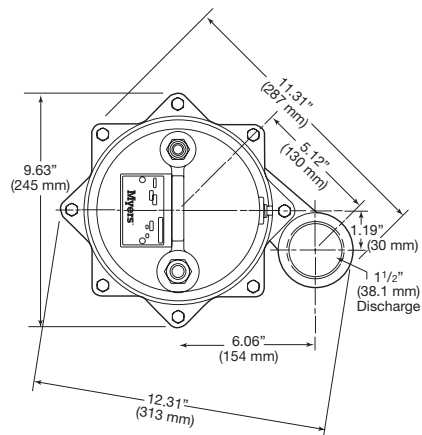

SINGLE & DUAL SEAL REPAIR PARTS LIST P SERIES

Ref. No.	Description	No. Req'd	Part No. P51D	Part No. P52D	Part No. P102D	Part No. P51S	Part No. P52	Part No. P102
1A	Nut, cord plug, solid	1				25341A002	25341A002	25341A002
1B	Washer, 1/32" Thick	1				05030A234	05030A234	05030A234
1C	Gasket, rubber	1				05014A193	05014A193	05014A193
1D	Washer, 3/32" Thick	1				05030A235	05030A235	05030A235
1	Cord, sensor	1	25339B000	25339B000	25339B000			
2	Cord, power	1	25338B002	25338B002	25338B002	25338B000	25338B001	25338B002
3	Screw, drive	2	05160A004	05160A004	05160A004	05160A004	05160A004	05160A004
4	Nameplate, blank, 1 ph	1	25488A000	25488A000	25488A000	25488A000	25488A000	25488A000
4	Nameplate, blank, 3 ph	1	25499A000	25499A000	25499A000	25499A000	25499A000	25499A000
5	Housing, motor	1	25327D000	25327D000	25327D000	25327D000	25327D000	25327D000
6	Capacitor (1 ph only)	1	23839A000	23839A000	23839A000	23839A000	23839A000	23839A000
7	Clip, capacitor (1 ph only)	1	20333A006	20333A006	20333A006	20333A006	20333A006	20333A006
8	Plug, 1/4" pipe	2	05022A009	05022A009	05022A009	05022A009	05022A009	05022A009
9	Oil, transformer (5 gal.)	1.12 gal	11009A006	11009A006	11009A006	11009A006	11009A006	11009A006
10	Screw, st. #10 x 3/8	2	09822A032	09822A032	09822A032	09822A032	09822A032	09822A032
11	Washer, bearing	1	19331A005	19331A005	19331A005	19331A005	19331A005	19331A005
12	Bearing, ball, upper	1	09565A013	09565A013	09565A013	09565A013	09565A013	09565A013
13 & 14	Stator, rotor shaft with shell	1	25484D200	25484D201	25484D205	25484D200	25484D201	25484D205
15	Wire, electrode	2	21792A004	21792A004	21792A004			
16	Screw #6 x 1/4	2	05434A025	05434A025	05434A025			
17	Seal probe	2	25343A000	25343A000	25343A000			
18	Bearing, ball, lower	1	08565A022	08565A022	08565A022	08565A022	08565A022	08565A022
19	Seal, shaft	2	25370A000	25370A000	25370A000	25370A000	25370A000	25370A000
20	Ring, retaining	2	12558A033	12558A033	12558A033	12558A033	12558A033	12558A033
21	Gasket, tetrseal, 7 x 6-3/4 x 1/8	2	05014A181	05014A181	05014A181	05014A181	05014A181	05014A181
22	Housing seal	1	25369D000	25369D000	25369D000	25367D000	25369D000	25369D000
23	Plate, bottom	1	25368D000	25368D000	25368D000		25368D000	25368D000
24	Screw, cap, 5/16 x 1-1/4	12	19100A012	19100A012	19100A012	19100A012	19100A012	19100A012
25	Impeller, plastic (std. series)	1	25332B010	25332B010	25332B000	25332B010	25332B010	25332B000
26	Case, volute	1	25330D000	25330D000	25330D000	25330D000	25330D000	25330D000
27	Cup, U, HUVA	1	22835A006	22835A006	22835A006	22835A006	22835A006	22835A006
28	Washer, impeller retainer	1	05030A242	05030A242	05030A242	05030A242	05030A242	05030A242
29	Screw, machine #10 x 3/8	1	06106A042	06106A042	06106A042	06106A042	06106A042	06106A042
30	Sealant (grade 271 Loctite®)	1	14550A001	14550A001	14550A001	14550A001	14550A001	14550A001

Units manufactured prior to Aug-2007 contact factory for repair parts.

WIRING DIAGRAM

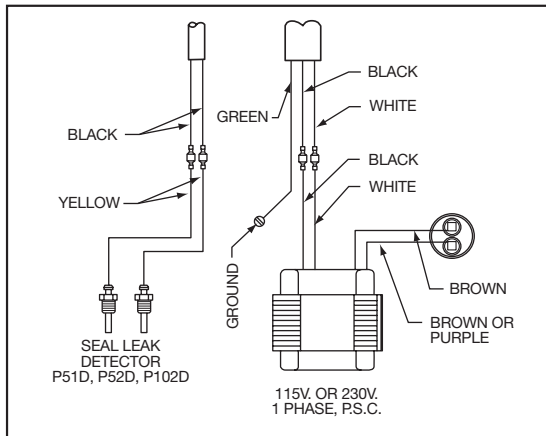

INCOMING 115V, 1 ph

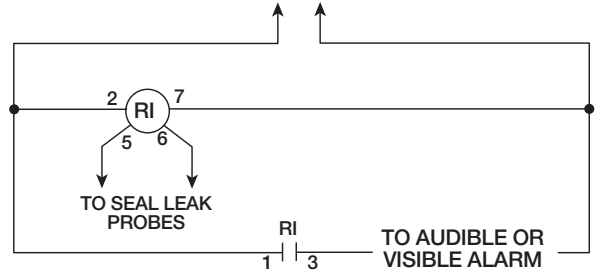

MOISTURE SENSOR SEAL PROBE CIRCUIT

Relay - SSAC INC. #LLC44A5A
Socket - STANDARD 8-PIN PLUG-IN TYPE
IF MYERS PANEL IS USED, SEE BELOW.

Pumps:

P51D, P51DB

Required Panel:

CMEP(SL)-11, -11SW. -11D or -11DW

Pumps:

P52D, P52DB
P102D, P102DB

Required Panel:

CMEP(SL)-21S, -21SW. -21D or -21DW

MOTOR RESISTANCE CHART							
HP	SPEED	V	PH	WINDING RESISTANCE IN OHMS		MAX. AMPS	LOCKED ROTOR AMPS
				BLACK TO WHITE	BRN. TO BRN. OR PURPLE		
1/2	3450	115	1	0.8/0.9	14.7	12	29.6
1/2	3450	230	1	9.8	19.7	6	15.0
1	3450	230	1	3.0/2.6	16.0/14.0	8	18.5

24" DIAMETER SIMPLEX P51 HOSE SYSTEM

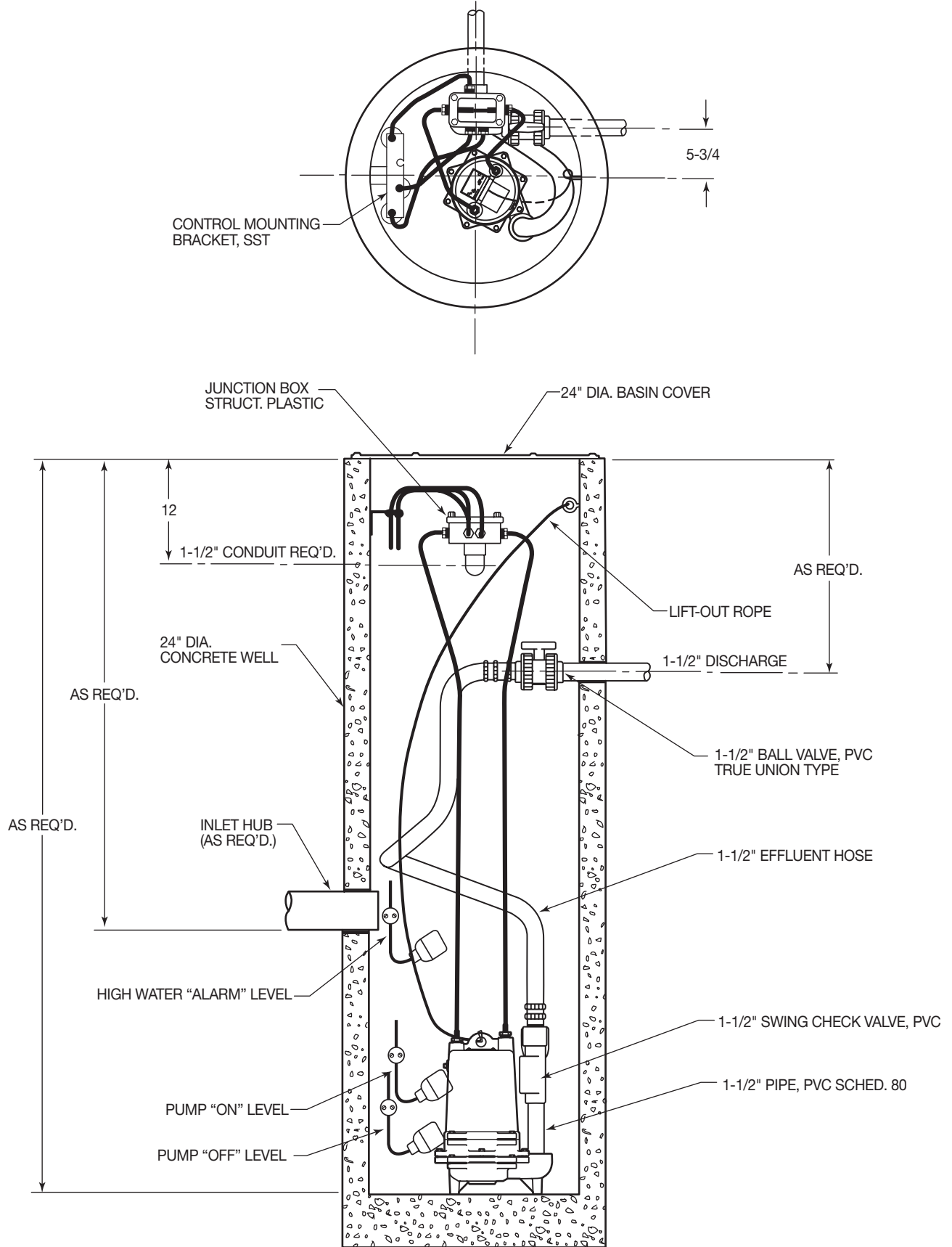

30" DIAMETER SIMPLEX P51 RAIL SYSTEM

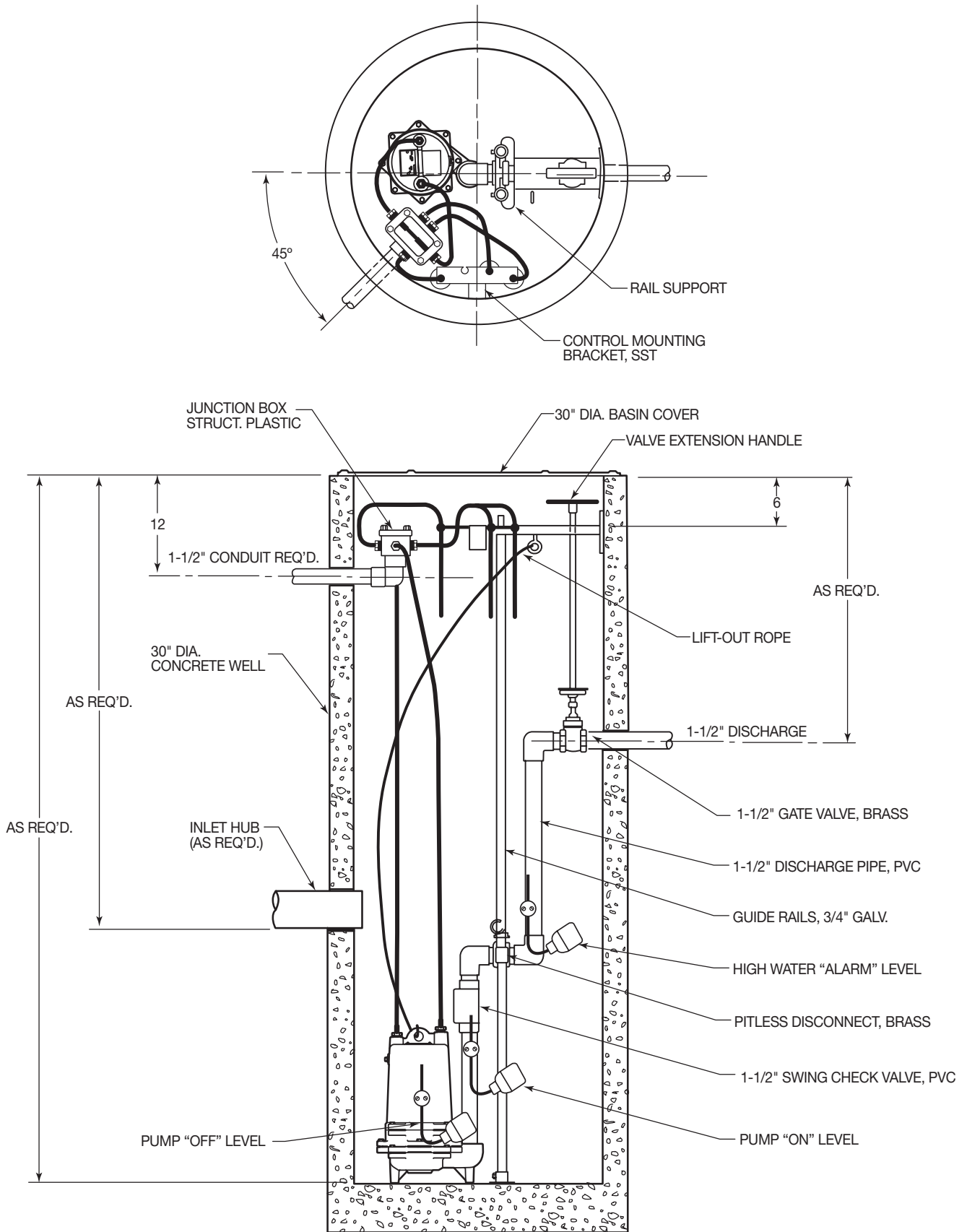

Limited Warranty

Myers® warrants to the original consumer purchaser ("Purchaser" or "You") of the products listed below, that they will be free from defects in material and workmanship for the Warranty Period shown below.

Product	Warranty Period
Jet pumps, small centrifugal pumps, submersible pumps and related accessories	whichever occurs first: 12 months from date of original installation, or 18 months from date of manufacture
Fibrewound Tanks	5 years from date of original installation
Steel Pressure Tanks	5 years from date of original installation
Sump/Sewage/Effluent Products	12 months from date of original installation, or 36 months from date of manufacture
Wastewater Solids Handling Pumps	12 months from date of shipment from factory or 18 months from date of manufacture

Our warranty applies only where such products are used in compliance with the requirements of the applicable product catalog and/or manuals. For additional information, please refer to the applicable standard limited warranty featured in the product manual.

Our warranty will not apply to any product that, in our sole judgement, has been subject to negligence, misapplication, improper installation, or improper maintenance. Without limiting the foregoing, operating a three phase motor with single phase power through a phase converter will void the warranty. Note also that three phase motors must be protected by three-leg, ambient compensated, extra-quick trip overload relays of the recommended size or the warranty is void.

Your only remedy, and MYERS's only duty, is that MYERS repair or replace defective products (at MYERS's choice). You must pay all labor and shipping charges associated with this warranty and must request warranty service through the installing dealer as soon as a problem is discovered. No request for service will be accepted if received after the Warranty Period has expired. This warranty is not transferable.

MYERS SHALL NOT BE LIABLE FOR ANY CONSEQUENTIAL, INCIDENTAL, OR CONTINGENT DAMAGES WHATSOEVER.

THE FOREGOING LIMITED WARRANTIES ARE EXCLUSIVE AND IN LIEU OF ALL OTHER EXPRESS AND IMPLIED WARRANTIES, INCLUDING BUT NOT LIMITED TO IMPLIED WARRANTIES OF MERCHANTABILITY AND FITNESS FOR A PARTICULAR PURPOSE. THE FOREGOING LIMITED WARRANTIES SHALL NOT EXTEND BEYOND THE DURATION PROVIDED HEREIN.

Some states do not allow the exclusion or limitation of incidental or consequential damages or limitations on the duration of an implied warranty, so the above limitations or exclusions may not apply to You. This warranty gives You specific legal rights and You may also have other rights which vary from state to state.

This Limited Warranty is effective February 7, 2014 and replaces all undated warranties and warranties dated after February 7, 2014.

F.E. MYERS

293 Wright Street, Delavan, WI 53115

Phone: 888-987-8677 • Fax: 800-426-9446 • www.femyers.com

In Canada:

490 Pinebush Road, Unit #4,

Cambridge, Ontario, Canada N1T 0A5

Phone: 800-363-7867 • Fax: 888-606-5484