

MYERS®

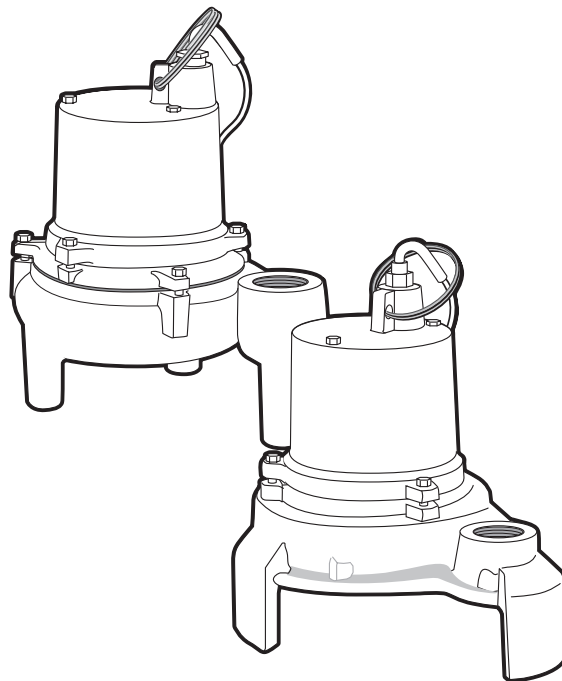

ME3F, ME3H Series

Important Safety Instructions

SAVE THESE INSTRUCTIONS - This manual contains important instructions that should be followed during installation, operation, and maintenance of the product. Save this manual for future reference.

▲ This is the safety alert symbol. When you see this symbol on your pump or in this manual, look for one of the following signal words and be alert to the potential for personal injury!

▲ DANGER indicates a hazard which, if not avoided, will result in death or serious injury.

▲ WARNING indicates a hazard which, if not avoided, could result in death or serious injury.

▲ CAUTION indicates a hazard which, if not avoided, could result in minor or moderate injury.

NOTICE addresses practices not related to personal injury.

CALIFORNIA PROPOSITION 65 WARNING:

▲ WARNING This product and related accessories contain chemicals known to the State of California to cause cancer, birth defects or other reproductive harm. **Carefully read and follow all safety instructions in this manual and on pump.**

Keep safety labels in good condition. Replace missing or damaged safety labels.

1. Read these rules and instructions carefully. Failure to follow them could cause serious bodily injury and/or property damage.
2. Check your local codes before installing. You must comply with their rules.
3. Vent sewage or septic tank according to local codes.
4. Do not install pump in any location classified as hazardous by National Electrical Code, ANSI/NFPA 80-1984 or the Canadian Electrical Code.

▲ WARNING Risk of electric shock. Can shock, burn or kill. During operation the pump is in water. To avoid fatal shocks, proceed as follows if pump needs servicing:

Do not smoke or use devices that can generate sparks in a septic (gaseous) environment.

- 5A. Disconnect power to outlet box before unplugging pump.
- 5B. Take extreme care when changing fuses. Do not stand in water or put your finger in the fuse socket.
- 5C. Do not modify the cord and plug. When using the cord and plug, plug into a grounded outlet only. When wiring to a system control, connect the pump ground lead to the system ground.
6. Be sure that construction and access to septic sumps conform with all OSHA requirements.
7. **▲ CAUTION Risk of burns.** Do not run the pump dry. Dry running can overheat the pump, (causing burns to anyone handling it) and will void the warranty.
8. **▲ CAUTION Risk of burns.** The pump normally runs hot. To avoid burns when servicing pump, allow it to cool for 20 minutes after shutdown before handling.

9. The pump is permanently lubricated. No oiling or greasing is required in normal operation. For overhaul, see instructions under *Service*.

When used in effluent dosing or S.T.E.P. applications, the pump must be installed in a separate tank or compartment at the discharge side of the septic tank.

NOTICE Never install the pump in the main tank where sludge collects. Do not use the pump for raw sewage.

Description

This submersible / effluent pump is designed for effluent dosing, Septic Tank Effluent Pumping (S.T.E.P.) and wastewater removal, sump drainage, dewatering and flood control. Units have built in thermal overload protection with automatic reset. The mechanical seal and sleeve bearings on the motor shaft are permanently lubricated. Stainless steel hardware and a heavy duty lift out handle allow for easy disassembly after extended use.

NOTICE This unit is not designed for applications involving salt water or brine! Use with salt water or brine will void warranty.

NOTICE This pump is not approved for, and should not be used in, swimming pools or fountains.

Specifications

Power Supply See Table 1 Motor Specifications
 Maximum Liquid Temperature. 120° F (49°C)
 Discharge Adapter. 1-1/2" NPT
 Maximum Solids Handling 3/4"
 Motor Type Shaded Pole
 RPM 1550
 Motor Insulation Class A
 Overload Protection Internal with Automatic Reset
 Bearings Double Sleeve
 Starting Switch Required None
 Control Panel Required None

Performance

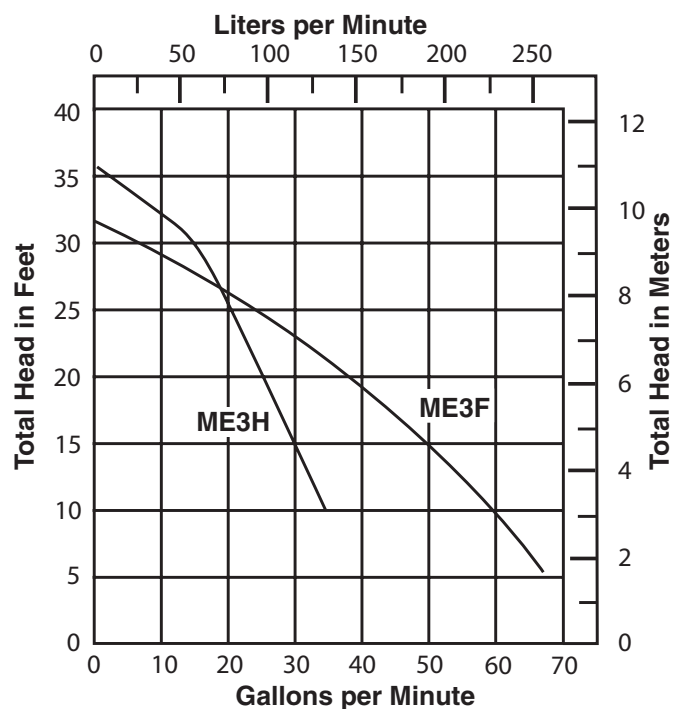

Table 1: Motor Specifications

Model Number	Pump Type	HP	Volts/Hz/Ph	Cord Length	Winding Branch Resistance In Ohms	Max. Amps.	Locked Rotor Amps	Circuit Req'd (Amps)
ME3H-11	Manual	1/3	115/60/1	20'	1.2	12.0	16.0	15
ME3F-11	Manual							
ME3H-11P	Auto							
ME3F-11P	Auto							
ME3H-21	Manual	1/3	230/60/1	30'	4.3	6.0	8.2	
ME3F-21	Manual							
ME3H-21P	Auto							
ME3F-21P	Auto							
ME3F-11P-30	Auto		115/60/1		1.2	12.0	16.0	

Installation

▲ WARNING Risk of electric shock. Can shock, burn or kill. Do not lift pump by the power cord. See *Cord Lift Warning* below.

NOTICE Install the pump on a hard, level surface (cement, asphalt, etc.). Never place the pump directly on earth, clay or gravel surfaces. Install the pump in a sump basin with a minimum diameter of 18" (46cm).

Piping

Piping must not be smaller than pump discharge.

The pump is designed to operate partially or completely submerged in effluent liquids and pump semi-solid fluids up to 3/4" (51mm) in diameter.

When installed in an effluent system, the pipe must be capable of handling semi-solids of at least 3/4" (19mm) in diameter.

The rate of flow in the discharge pipe must keep any solids present in suspension in the fluid. To meet minimum flow requirements (2 feet per second in the discharge line), size the pipe as follows:

A Pipe Size Of:	Will Handle a Flow Rate Of:
1-1/2" (38mm)	12 GPM
2" (51mm)	21 GPM
2-1/2" (64mm)	30 GPM
3" (76mm)	48 GPM

In an effluent system use a 1-1/2" (38mm) check valve in pump discharge to prevent backflow of liquid into sump basin. The check valve should be a free flow valve that will easily pass solids. Be sure check valve installation complies with local codes.

Be sure that the float switch hangs freely. It should not be able to come in contact with the sides or bottom of the sump pit.

Make sure the sump pit is free of any debris that could obstruct the intake volute or switch.

Use plumbing materials that are approved by local building codes when connecting pipes between pump and sewer outlet.

NOTICE For critical indoor installations where additional high water protection is desired, install an audible alarm system in the sump pit. For outdoor installations, confer with your distributor.

Connect the power cord to a 3-prong grounded AC receptacle.

▲ WARNING Risk of electric shock. Can shock, burn or kill. DO NOT remove the grounding pin from the power cord. Avoid using extension cords or 2-prong adapter plugs.

Insert the piggyback plug that comes from the float switch directly into the power receptacle.

Insert the pump power cord directly into the back of the switch's piggyback plug/receptacle.

Cord Lift Warning



▲ WARNING

Risk of electrical shock.
Can burn or kill.
Do not lift pump by power cord.

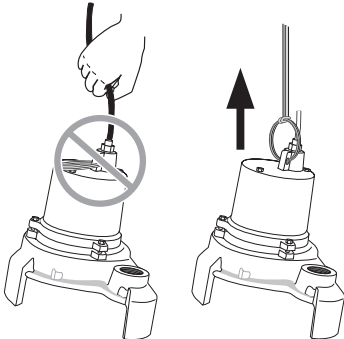

1. Attempting to lift or support pump by power cord can damage cord and cord connections.
2. Cord may pull apart, exposing bare wires with possibility of fire or electrical shock.
3. Lifting or supporting pump by power cord will void warranty.
4. Use lifting ring or handle on top of pump for all lifting/lowering of pump. Disconnect power to pump before doing any work on pump or attempting to remove pump from sump.

Test the pump installation by filling the sump basin with enough water to activate the pump and repeat this cycle until satisfied with pump operation.

NOTICE For best performance of check valve when handling solids, do not install it with the discharge more than 45° above the horizontal. Do not install the check valve in a vertical position as solids may settle in the valve and prevent it from opening on startup.

Drill a 1/8" (3mm) hole in the discharge pipe below the check valve to prevent airlocking the pump.

Electrical

▲WARNING Risk of electric shock. Can shock, burn or kill. When installing, operating, or servicing this pump, follow the safety instructions listed below.

1. DO NOT splice the electrical power cord.
2. DO NOT allow the plug on the end of the electrical cord to be submerged.
3. DO NOT use extension cords. They are a fire hazard and can reduce voltage sufficiently to prevent pumping and/or damage motor.
4. DO NOT handle or service the pump while it is connected to the power supply.
5. DO NOT remove the grounding prong from the plug or modify the plug. To protect against electrical shock, the power cord is a three-wire conductor and includes a 3-prong grounded plug. Plug the pump into a 3-wire, grounded, grounding-type receptacle. Connect the pump according to the NEC or CEC and local codes.

Automatic models are equipped with a 20' mechanical (mercury free), piggy-back float switch tethered directly to the pump. The switch can also be mounted on the discharge pipe, with a minimum 4" tether length. The switch must float free from the pump and the basin wall. Tape or cable-tie the cord to the discharge pipe every 12". Plug the switch into a properly grounded, grounding-type receptacle of the correct voltage. The receptacle must be installed according to all applicable codes.

On all duplex units or simplex units with additional options such as a high water alarm, cut off the power cord plug and wire the pump into a control panel (or sealed junction box if it is installed in a wet sump or basin). The AWS-1 control also acts as a sealed junction box for connecting the power cord to the pump cord.

Connect or wire pump to its own individual branch circuit with no other outlets or equipment in the circuit. Size fuses or circuit breakers according to *Table 1, Motor Specifications*.

▲WARNING Risk of fire and explosion. Can cause severe injury, property damage or death. Be sure that power supply information (Voltage/ Hertz/Phase) on pump motor nameplate matches incoming power supply exactly. Install pump according to all electrical codes that apply.

Operation

▲WARNING Risk of fire and explosion. Can cause severe injury, property damage or death. Do not use in explosive atmospheres. Pump water only with this pump.

NOTICE Do not allow the pump to run in a dry sump. It will void the warranty and may damage the pump.

An automatic overload protector in the motor will protect the motor from burning out due to overheating/overloading. When the motor cools down, the overload protector will automatically reset and start the motor.

If the overload trips frequently, check for the cause. It could be a stuck impeller, wrong/low voltage, or an electrical failure in the motor. If an electrical failure in the motor is suspected, have it serviced by a competent repairman.

The pump is permanently lubricated. No oiling or greasing is required.

Cycle the pump at least once every month to be sure that the system is working satisfactorily.

NOTICE Any of the following will void the pump warranty:

1. Submerging, plugging, damaging or taping shut a vented cord.
2. Pumping materials other than those the pump was designed to pump or continuously pumping water hotter than 120°F (49°C).
3. Cutting or splicing a power cord or switch cord.
4. Removing the cord tag from the cord.

Service

General

▲WARNING Risk of electric shock. Can shock, burn or kill. Before removing the pump from the basin for service, always disconnect electrical power to the pump and the control switch. Do not lift the pump by the power cord. See the *Cord Lift Warning*.

Disinfect the Pump

Place the pump in an area where it can be cleaned thoroughly. Remove all scale and deposits on the pump.

▲WARNING Risk of infection. Submerge the complete pump in a disinfectant solution (dilute chlorine bleach) for at least one hour before disassembling the pump.

The pump motor housing contains a special lubricating oil which should be kept clean and free of water at all times.

NOTICE Whenever the motor housing is being removed for service, remove oil and replace it with new oil at reassembly. Use only oil listed in parts list in this manual. When filling with new oil, DO NOT overfill. Be sure that the oil level is 3/4" below the top of the cover.

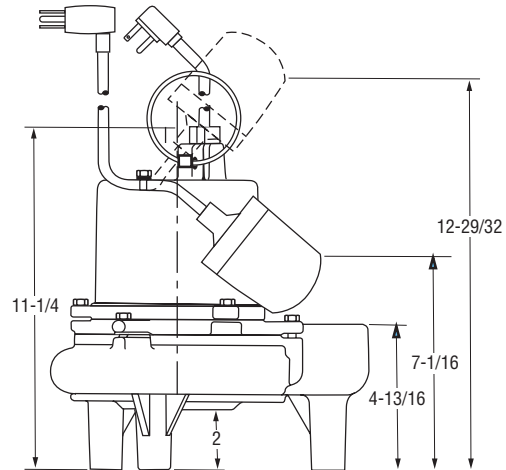
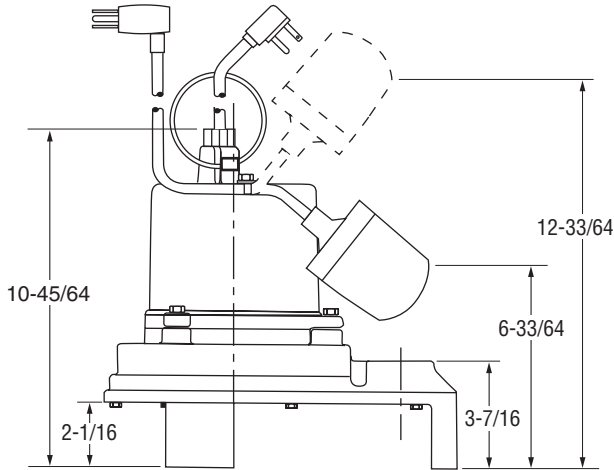
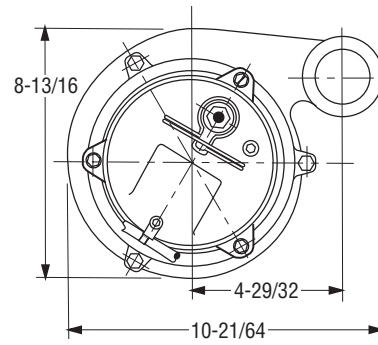
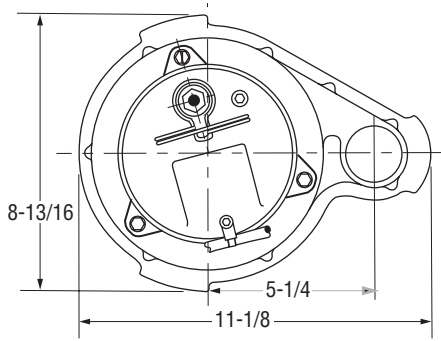

Figure 1: ME3H Dimensions

Figure 2: ME3F Dimensions

⚠ WARNING Risk of explosion and hazardous gas. Never enter the pump chamber after effluent has been in the basin. Sewage water can give off methane, hydrogen sulfide, or other gases which are highly poisonous.

For this reason, the manufacturer recommends installing effluent pumps with a quick removal system – either a union with a cam and groove fitting coupling if the pipe is within reach from the top of the tank, or a rail system type quick disconnect on deeper systems. See Figures 4, 5, and 6 for typical installations.

Construct the dosing tank or pumping chamber of corrosion resistant materials and design it to withstand all anticipated internal and external loads. The tank must not allow infiltration or exfiltration, and must have anti-buoyancy provisions. Include access holes or covers accessible on the surface and of adequate size to allow installation and maintenance of the system. Make access covers lockable or heavy enough to prevent easy access by unauthorized personnel. Calculate the pumping chamber holding capacity to allow for emergencies.

The discharge pipe must be at least 1-1/2" diameter (pump discharge size or larger). See *Piping* for minimum flow requirements. Install a full flow gate or ball valve as a shutoff valve in the discharge, to prevent backflow in case the pump must be removed for service. A Pressure Sewage System must also have a check valve installed. In other systems, if conditions allow, a check valve will prevent backflow and reduce wear and tear on the system.

Install a high-water alarm system on a separate circuit from the pump circuit. The alarm should be testable for proper operation.

Maintenance

⚠ WARNING Risk of electric shock. Can shock, burn or kill. Before working on pump or switch, always turn off the circuit breaker or fuse and unplug the switch cord and power cord.

Automatic Float Switch Replacement

⚠ CAUTION Possible contamination. Wear rubber gloves when working on switch. Dispose of old switch according to ordinances.

1. Disconnect the power at the circuit breaker or fuse box and unplug the piggy-back float switch cord from the receptacle.
2. Unplug the pump power cord from the back of the piggy-back float switch plug.
3. If you cannot reach the switch tether point, remove the pump from the sump.
4. Disconnect the switch from its tether point and remove it from the discharge piping.
5. Attach the new switch to the pump or the discharge piping. Don't change the tether length or the attachment point.
6. Attach the power and switch cords to the discharge piping with cable ties or electrician's tape.
7. Plug the switch into the receptacle.

8. Plug the pump's power cord into the back of the piggy-back switch plug.
9. Replace the pump in the basin.
10. Turn on the power to the receptacle.
11. Fill the basin and test operation through one complete operational cycle.

NOTICE Failure to make this operational check can lead to flooding.

ME3F / ME3H Seal Change

⚠ WARNING Risk of electric shock. Can shock, burn or kill. Before removing pump from basin for service, always disconnect electrical power to pump and control switch and unplug the pump and switch.

⚠ WARNING Risk of infection. Submerge complete pump in a disinfectant solution (dilute chlorine bleach) for at least one hour before disassembling pump.

The pump motor contains a special lubricating oil which should be kept clean and free of water at all times.

1. Remove the oil fill plug located on top of the motor housing and drain the oil in the housing.
NOTICE Dispose of the oil according to ordinance. Do not reuse the oil since it may contain water from seal failure.
2. **ME3F** (See Below for ME3H): Remove three cap screws (see Figure 3) holding the volute case to the motor housing/seal plate assembly. Lift the motor housing/seal plate assembly off the volute case and lay it on its side.

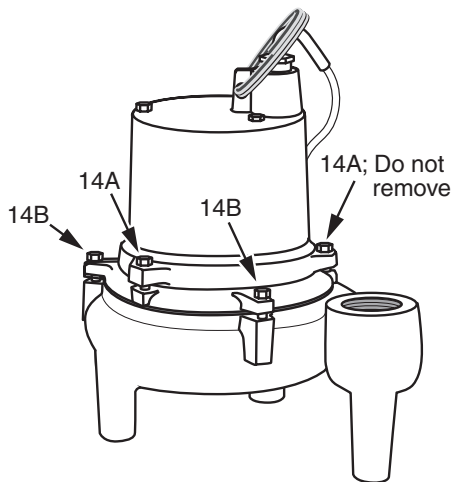

Figure 3: For Model ME3F, be sure to remove the three screws (Ref. No. 14B) holding the motor housing/seal plate assembly to the volute case, not the screws (Ref. No. 14A) holding the motor housing to the seal plate.

ME3H: Lay the pump on its side. Remove nine screws holding the suction plate to the bottom of the volute case. Carefully remove the suction plate and gasket.

3. Hold the shaft with a screwdriver in the slot on the end of the shaft. Carefully tap the impeller counterclockwise with a rubber mallet to loosen it. Unscrew and remove the impeller.

4. Pull the rotating half of the seal off of the shaft with your fingers, then use two straight-bladed screwdrivers to pry the stationary half of the seal out of the seal cavity in the seal plate.

NOTICE Discard all the old seal parts. Do not try to reuse the old seal.

5. Clean the shaft and volute casing with a clean cloth. If there were any signs of water in the oil, air-dry the motor for several days to be sure that there is no moisture in the motor at reassembly.
6. Wipe an oil film onto the outside of the rubber ring on the stationary (carbon faced) half of the new seal. Don't get any oil on the carbon face of the seal.
7. Slide the stationary seal-half down the shaft and into the seal cavity in the seal plate, rubber ring first, carbon face out. Put a cardboard washer over the carbon face to protect it and press the seal half into the seal cavity, using a small piece of tubing or pipe as the press. Be sure that you don't chip, scratch, or crack the carbon seal face.
8. Once the stationary seal half is in place, check it to be sure that there are no chips, cracks, scratches, debris, dust, etc., on the carbon face of the seal.
9. Wipe a film of oil onto the impeller shaft, then slide the rotating (ceramic faced) half of the seal onto the shaft, ceramic face first, rubber surface out. When correctly installed, the carbon and ceramic faces will face each other.
10. Thread the impeller onto the shaft (turn clockwise) while holding the shaft with a straight-bladed screwdriver in the slot in the end of the shaft. Tighten the impeller on the shaft. Once the impeller is tight, spin the impeller/shaft assembly to be sure that there is no binding.
11. **ME3F ONLY** (ME3H go on to Step 12): Check the HUCA cup seal in the volute case inlet. If it shows signs of wear, replace it.
12. **ME3F** (See below for ME3H): Turn the motor housing/seal plate assembly upright and set it in place in the volute case. Insert and tighten three cap screws to secure the volute case to the seal plate.
ME3H: Replace the suction plate and gasket on the bottom of the volute casing. Replace and tighten the nine screws holding the plate to the casing. Stand the pump upright.
13. Refill the motor housing with fresh oil, using only Myers submersible transformer oil. After filling, use a dipstick to make sure that the oil is 3/4" below the top of the motor housing.
14. Replace the pump in the basin, reconnect the plumbing, plug it in, and fill the basin sufficiently to start the pump and check operation. The pump should run quietly, be vibration free, and pump down the basin normally.

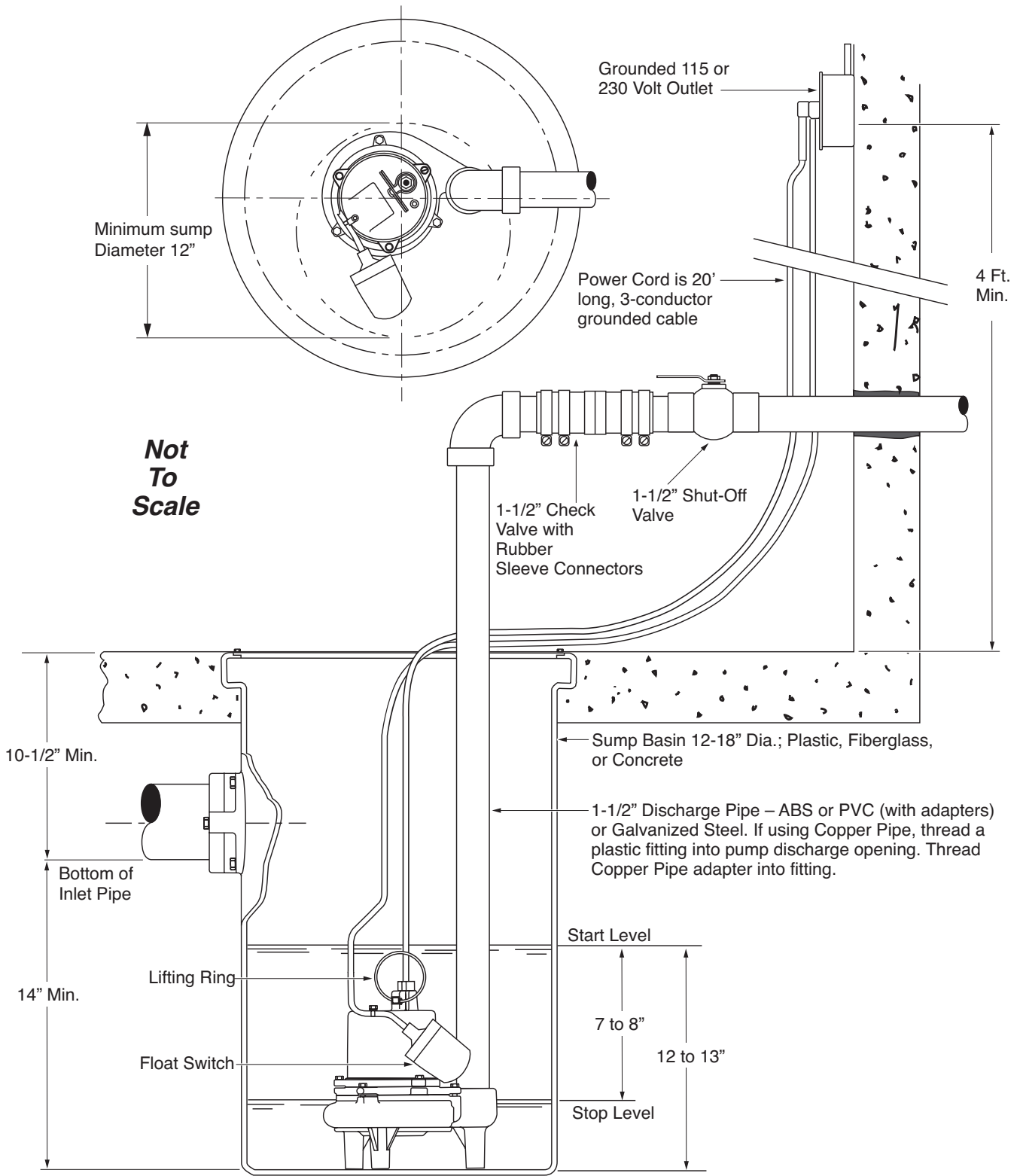

Figure 4: Typical Sump Installation

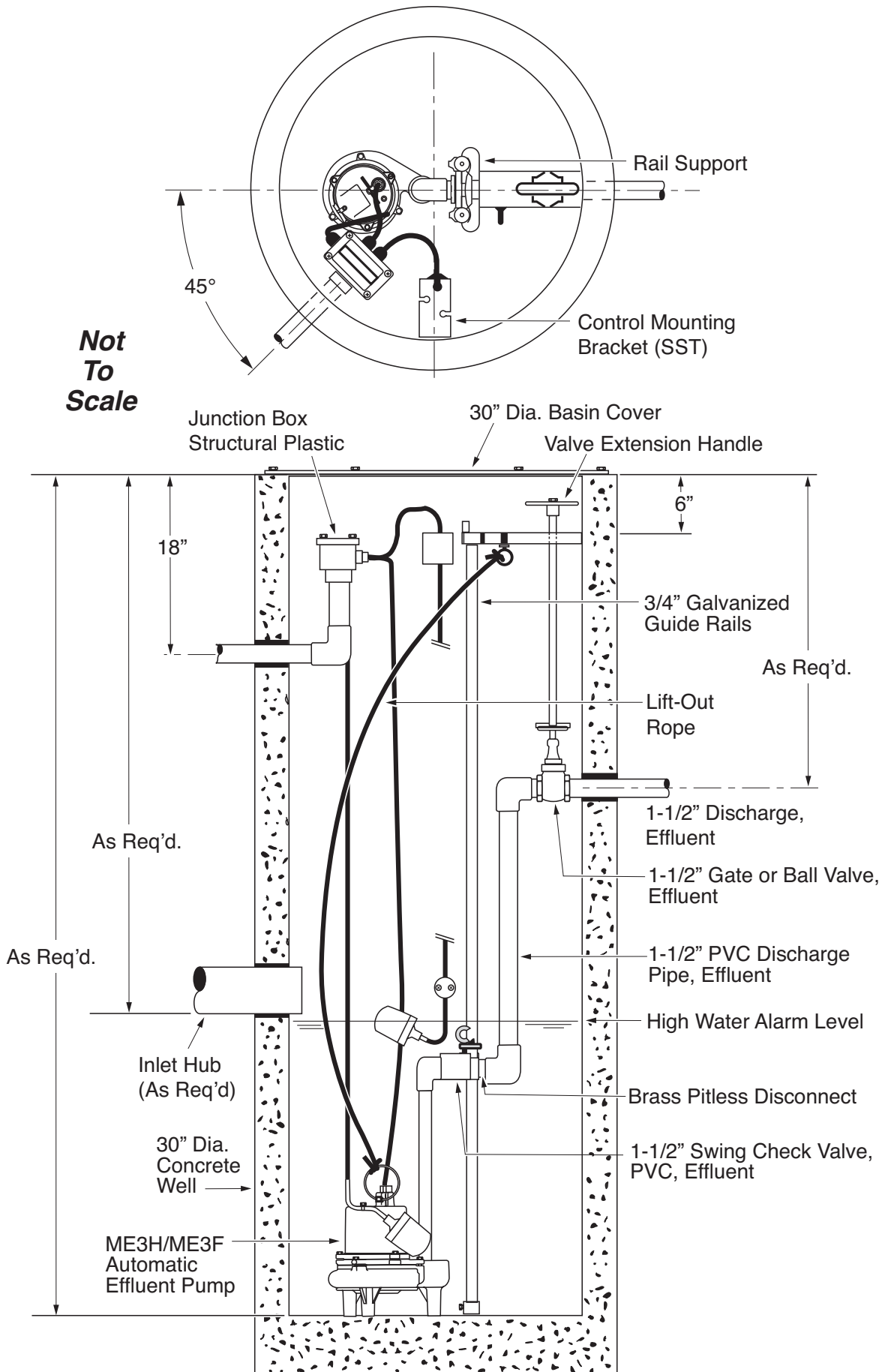

Figure 5: 30" Diameter Simplex Installation with Guide Rail Liftout System

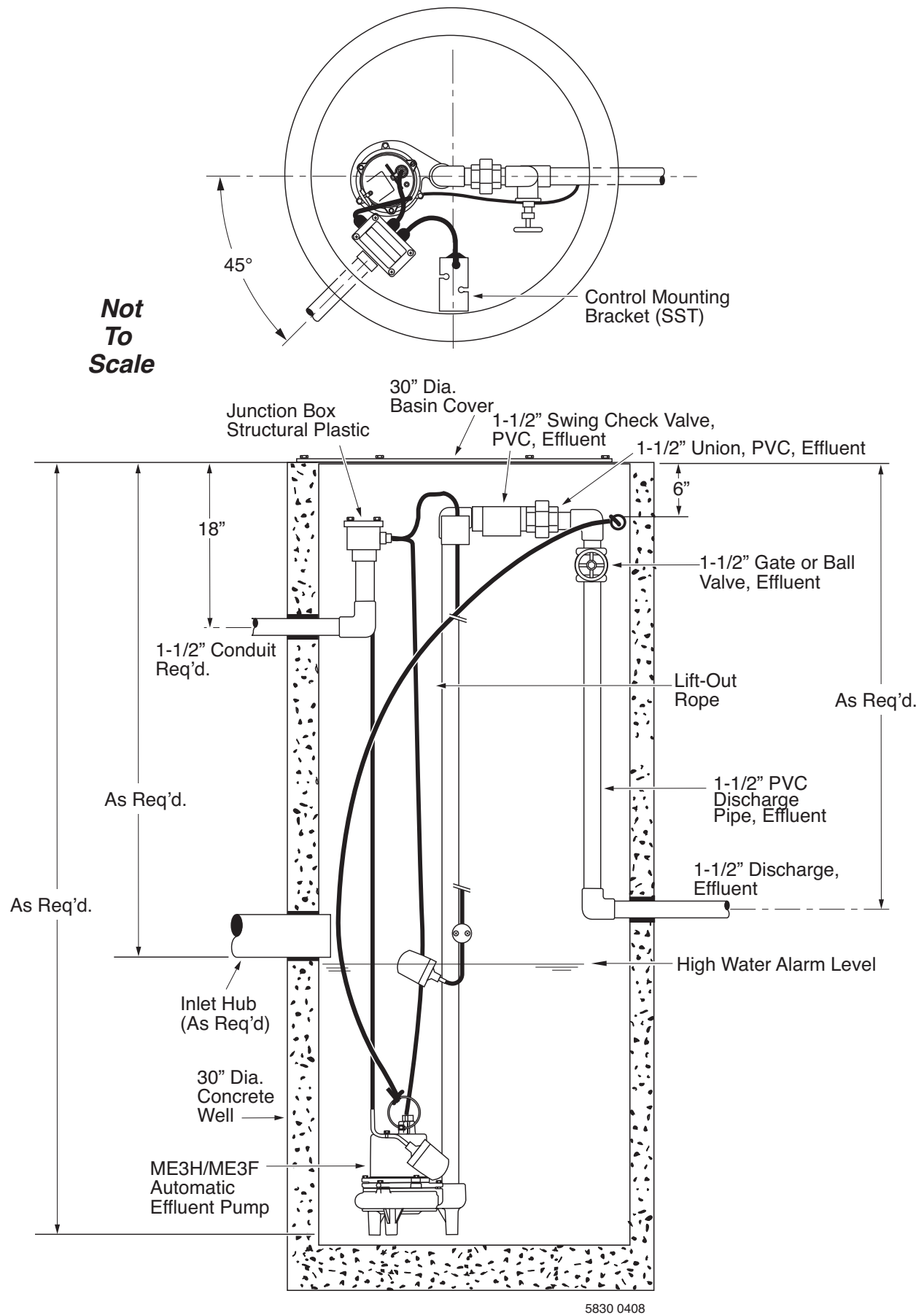

Figure 6: 30" Diameter Simplex System with Union

Troubleshooting Chart

⚠ WARNING Risk of cuts and possible unexpected starts. If the power is on to the pump when thermal overload resets, the pump may start without warning. If you are working on the pump, you may get an electrical shock or the impeller may catch fingers or tools. Disconnect the power before servicing the pump.

A. Pump fails to operate:	1. Check to be sure that power cord is securely plugged into outlet or securely wired into controller or switch box.
	2. Check to be sure you have electrical power. Be sure that the piggyback plugs are tight.
	3. Check that liquid fluid level is high enough to activate switch or controller.
	4. Check to be sure that 1/8" (3 mm) vent hole in discharge pipe is not plugged.
	5. Check for blockage in pump inlet, impeller, check valve or discharge pipe.
	6. Disconnect the pump from the power source for a minimum of 30 minutes to allow the motor to cool and to protect yourself from sudden starts. See Warning above. Check for the cause of overheating. Pump is running dry because the float switch is caught up on something. Inlet pipe is plugged. Outlet pipe is plugged.
	7. Motor windings may be open. Take unit to authorized service center.
B. Pump fails to empty sump:	1. Be sure all valves in discharge pipe are fully open.
	2. Clean out discharge pipe and check valve.
	3. Check for blockage in pump inlet or impeller.
	4. Pump not sized properly. A higher capacity pump may be required.
C. Pump will not shut off:	1. Check switch or controller automatic floats for proper operation and location. See installation instructions for switch/controller.
	2. If pump is completely inoperative or continues to malfunction, consult your local serviceman.

Repair Parts

Model ME3F

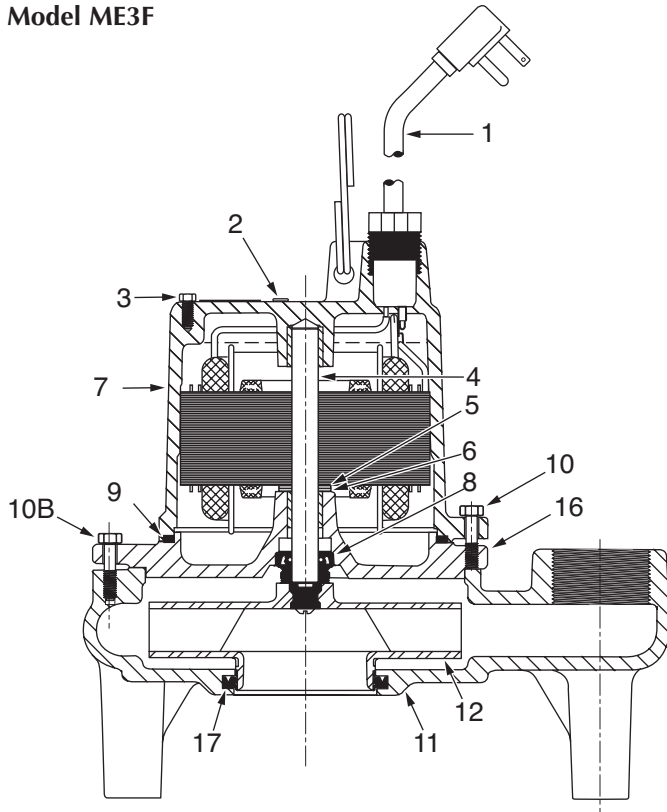

Ref.	Description	Qty.	Part Number
1	20' Power Cord (115V)	1	21628B048
	20' Power Cord (230V)	1	21628B049
2	1/4" NPT Plug	1	149810011
3	Self-Tapping Screw (Manual) #10x3/8"	1	*
	Self-Tapping Screw (Auto) #6x5/16"	1	*
4	Rotor with Shaft	1	22821A000
5	SST Thrust Washer	1	05030A243
6	Graphite Thrust Washer	1	05030A244
7	Motor Housing w/Stator (115V)	1	23770D060K
	Motor Housing w/Stator (230V)	1	23770D061K

* Standard hardware item – purchase locally.

Model ME3H

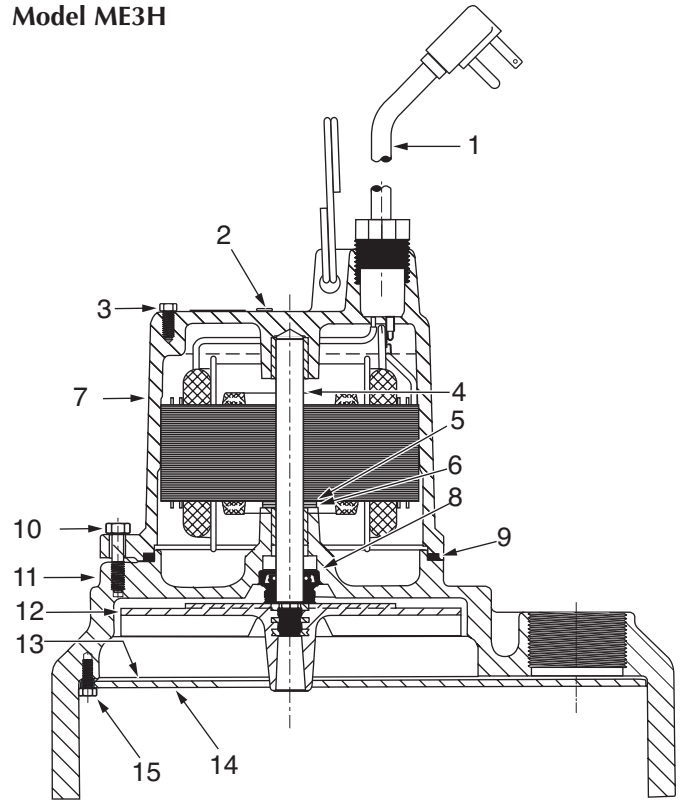

Ref.	Description	Qty.	Part Number
8	1/2" Shaft Seal	1	21607A001
9	Rubber Gasket	1	05014A172
10	1/4-20x7/8" Cap Screw	3	*
10B	1/4-20x7/8" Cap Screw (ME3F)	3	*
11	Volute Case (ME3H)	1	26221D000
	Volute Case (ME3F)	1	26226D000
12	Impeller (ME3H)	1	26223C000
	Impeller (ME3F)	1	25301B000
13	Gasket	1	26225C000
14	Suction Plate	1	26222C000
15	Self-Tapping Screw #10x1/2"	9	*
•	115V 20' Piggy-Back Switch	1	21813B131
	230V 20' Piggy-Back Switch	1	21813B133
16	Seal Plate	1	26227D000
17	HUVA Cup Seal	1	22835A007

• Not Illustrated

Limited Warranty

Myers® warrants to the original consumer purchaser ("Purchaser" or "You") of the products listed below, that they will be free from defects in material and workmanship for the Warranty Period shown below.

Product	Warranty Period whichever occurs first:
Jet pumps, small centrifugal pumps, submersible pumps and related accessories	12 months from date of original installation, or 18 months from date of manufacture
Fibrewound Tanks	5 years from date of original installation
Steel Pressure Tanks	5 years from date of original installation
Sump/Sewage/Effluent Products	12 months from date of original installation, or 36 months from date of manufacture
Battery Backup Units MBSP-2, MBSP-2C	12 months from date of original installation, or 18 months from date of manufacture
MBSP-3, MBSP-3C	24 months from date of original installation, or 30 months from date of manufacture
Wastewater Solids Handling Pumps	12 months from date of shipment from factory or 18 months from date of manufacture

Our warranty applies only where such products are used in compliance with the requirements of the applicable product catalog and/or manuals. For additional information, please refer to the applicable standard limited warranty featured in the product manual.

Our warranty will not apply to any product that, in our sole judgement, has been subject to negligence, misapplication, improper installation, or improper maintenance. Without limiting the foregoing, operating a three phase motor with single phase power through a phase converter will void the warranty. Note also that three phase motors must be protected by three-leg, ambient compensated, extra-quick trip overload relays of the recommended size or the warranty is void.

Your only remedy, and MYERS's only duty, is that MYERS repair or replace defective products (at MYERS's choice). You must pay all labor and shipping charges associated with this warranty and must request warranty service through the installing dealer as soon as a problem is discovered. No request for service will be accepted if received after the Warranty Period has expired. This warranty is not transferable.

MYERS SHALL NOT BE LIABLE FOR ANY CONSEQUENTIAL, INCIDENTAL, OR CONTINGENT DAMAGES WHATSOEVER.

THE FOREGOING LIMITED WARRANTIES ARE EXCLUSIVE AND IN LIEU OF ALL OTHER EXPRESS AND IMPLIED WARRANTIES, INCLUDING BUT NOT LIMITED TO IMPLIED WARRANTIES OF MERCHANTABILITY AND FITNESS FOR A PARTICULAR PURPOSE. THE FOREGOING LIMITED WARRANTIES SHALL NOT EXTEND BEYOND THE DURATION PROVIDED HEREIN.

Some states do not allow the exclusion or limitation of incidental or consequential damages or limitations on the duration of an implied warranty, so the above limitations or exclusions may not apply to You. This warranty gives You specific legal rights and You may also have other rights which vary from state to state.

This Limited Warranty is effective April 1, 2014 and replaces all undated warranties and warranties dated before April 1, 2014.

F.E. MYERS

293 Wright Street, Delavan, WI 53115

Phone: 888-987-8677 • Fax: 800-426-9446 • www.femyers.com

In Canada: 490 Pinebush Road, Unit 4, Cambridge, Ontario N1T 0A5

Phone: 800-363-7867 • Fax: 888-606-5484