



QC10 SERIES QUICK-CHANGE WATER FILTER SYSTEM  
INSTALLATION AND OPERATION MANUAL



## SPECIFICATIONS

Pressure Range:	30–125 psi (2.1–8.62 bar)
Temperature Range:	40–100°F (4.4–37.8°C)
Rated Service Flow:	
QC10-CBR	0.5 gpm (1.9 Lpm)
QC10-EP	0.5 gpm (1.9 Lpm)
QC10-GAC	0.75 gpm (2.8 Lpm)
QC10-TSGAC*	0.75 gpm (2.8 Lpm)
QC10-CGAC*	0.6 gpm (2.3 Lpm)
QC10-CB1*	0.6 gpm (2.3 Lpm)
Size:	2.187-inch x 11.625-inch (55.5 mm x 295.3 mm)

\*Not Performance Tested or Certified by NSF.

## PARTS INCLUDED

- Filter head with built-in bracket and compression or push-fit fittings
- Cartridge
- Hardware kit

## TOOLS AND MATERIALS REQUIRED

- Phillips screwdriver
- Adjustable wrench (for 1/4-inch male threaded parts)
- Tape measure
- Pencil
- Safety glasses
- Separate drinking water faucet required if supplying water directly to the kitchen sink

## OPTIONAL MATERIALS

- Shut-off valve
- Saddle tap valve with shut-off
- Threaded copper "T"
- 1/4-inch (6.35 mm) plastic or copper tubing or flexible hose
- 3/8-inch (9.53 mm) plastic or copper tubing or flexible hose

## PRODUCT SPECIFICATIONS

Model	Claims	Filter Capacity	Rated Service Flow	Micron Rating	1/4-inch Threaded	1/4-inch JG Push fit	3/8-inch JG Push fit	Replacement Cartridge
QC10-CBR	chlorine taste & odor, sediment, lead, atrazine, lindane	500 gallons (1,890 L)	0.5 gpm (1.9 L/min)	0.5	158667	158682	158691	QC10-CBRR 155785-43
QC10-EP	chlorine taste & odor	1,500 gallons (5,670 L)	0.5 gpm (1.9 L/min)	5*	158668	158683	158692	QC10-EPR 155962-43
QC10-GAC	chlorine taste & odor	2,500 gallons (9,460 L)	0.75 gpm (2.8 L/min)	–	158669	158684	158693	QC10-GACR 155901-43
QC10-TSGAC*	chlorine taste & odor with phosphate crystals*	1,700 gallons (6,435 L)*	0.75 gpm (2.8 L/min)*	–	–	158723	158724	QC10-TSGACR 255706-43
QC10-CGAC*	chloramine taste & odor and chlorine taste & odor*	500 gallons (1,890 L)*	0.6 gpm (2.3 L/min)*	–	–	158719	158720	QC10-CGACR 255704-43
QC10-CB1*	chlorine taste & odor and sediment*	10,000 gallons (37,850 L)*	0.6 gpm (2.3 L/min)*	–	–	158721	158722	QC10-CB1R 255705-43

\*Not Performance Tested or Certified by NSF.

## PRECAUTIONS

**⚠ WARNING:** Do not use with water that is microbiologically unsafe or of unknown quality without adequate disinfection before or after the system.

**CAUTION** Protect against freezing to prevent cracking of the filter and water leakage.

**CAUTION** Because of the product's limited service life and to prevent costly repairs or possible water damage, we strongly recommend that the head of the filter be replaced every ten years. If the head of your filter has been in use for longer than this period, it should be replaced immediately. Date the top of any new head to indicate the next recommended replacement date.

**CAUTION** Turn off water supply to head without cartridge if it must be left unattended for an extended period of time.

**NOTE:** Spent adsorption media will not be regenerated and used.

**NOTE:** If adsorption media is affected by chlorine, water supply should be treated to remove chlorine prior to entering filter.



The QC10-CBR is Tested and Certified by NSF International against NSF/ANSI Standard 42 and 53 for the reduction of claims specified on the performance data sheet.



The QC10-EP and QC10-GAC are Tested and Certified by NSF International against NSF/ANSI Standard 42 for the reduction of claims specified on the performance data sheet.

# INSTALLATION

**NOTE:** For cold water use only.

**NOTE:** Make certain that installation complies with all state and local laws and regulations.

**NOTE:** The contaminants or other substances removed or reduced by the selected cartridge are not necessarily in your water. Filter must be maintained according to manufacturer's recommendation including replacement of filter cartridges. Ask your local water municipality for a copy of their water analysis, or have your private well tested by a reputable water testing lab.

**NOTE:** After prolonged periods of non-use (such as during a vacation) it is recommended that the system be flushed thoroughly. Let water run for 2-3 minutes before using.

**NOTE:** The filter cartridge used with this system has a limited service life. Changes in taste, odor, color, and/or flow of the water being filtered indicate that the cartridge should be replaced.

## 1. Mounting the Filter System

A. Select a location where filter system is to be mounted.

**NOTE:** Allow 1-1/2 inches (38 mm) clearance below housing or 11-inches (279 mm) below filter head to enable filter cartridge changes.

**CAUTION** Filter head should be mounted securely to a solid stud or surface. The mounting bracket will support the weight of the filter and help prevent strain on the cold water line.

B. Filter head should be mounted in vertical position. Use mounting bracket as a template to mark screw locations. Mount filter head in marked location using the screws provided in the hardware kit.

**CAUTION** Cold water supply to the filter should have a separate shut-off valve. If it does not, a separate shut-off should be installed.

## 2. Connecting the Tubing and Fittings

A. Assemble fittings as shown in Figure 2A. Press appropriate tubing into the inlet and outlet fittings until it stops. Hand-tighten connections. Then tighten 1 to 1-1/2 turn(s) with a wrench.

B. Cut and deburr 1/4-inch or 3/8-inch tubing. Insert tubing into push fittings. Push tubing in until you hit a hard stop as shown in Figure 2B, page 3. To remove tubing from fitting, depress tube collar around the tube while pulling the tube out.



## 3. Installing the Cartridge

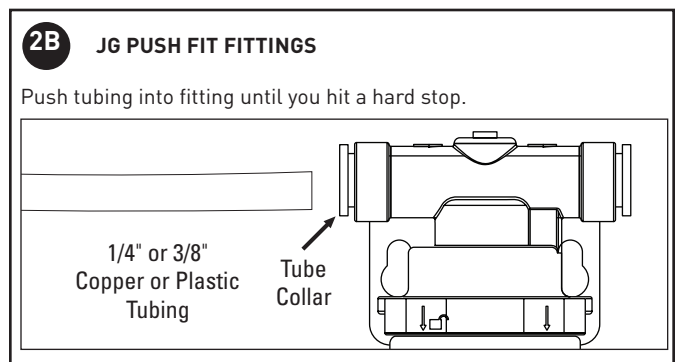
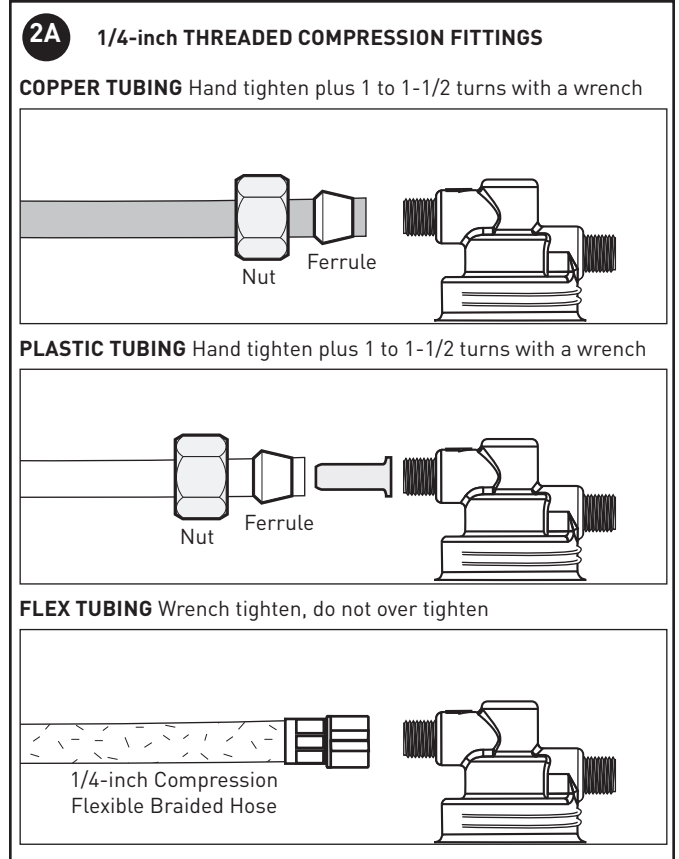
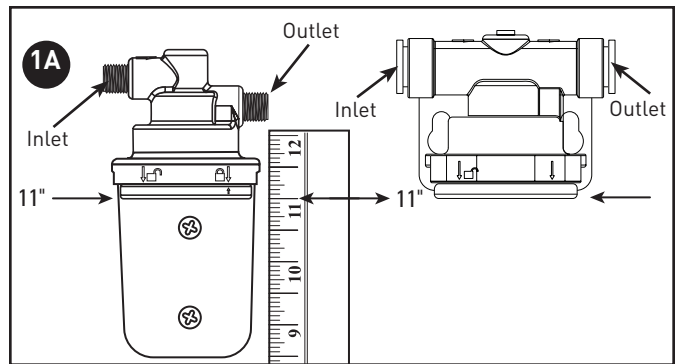

See Filter Cartridge Replacement, Step R3, for installation instructions.



## **FILTER CARTRIDGE REPLACEMENT**

(R1) Relieve pressure by turning off water supply to the filter and dispensing water from the faucet.

(R2) (a) Twist cartridge away from the locked position  to the unlock position , and (b) remove cartridge (R2).

(R3) (c) Line up arrow  on replacement cartridge with the unlocked position  on head and firmly push cartridge into head and (d) turn to locked position  (R3).

(R4) Turn on water and check for leaks. If leaks are found, see Troubleshooting section, page 4.

**NOTE: A water cartridge may contain carbon fines (very fine black powder). This will be released during your initial flushing.**

(R5) Flushing the System:

System: QC10-CBR: Flush water through filter for fifteen minutes to remove carbon fines.

Systems: QC10-EP, QC1-GAC, QC10-TSGAC, QC10-CGAC & QC-10CB1: Flush water through filter for five minutes to remove carbon fines.

(R6). Check for leaks again before leaving installation.

## **TROUBLESHOOTING**

### **Leaks:**

#### **...Between head and cartridge**

1. Turn off the water supply to the filter and dispense water from faucet.
2. Remove cartridge and inspect o-rings to make sure they are in place and clean.
3. Install cartridge and turn on water supply, if it still leaks, contact Technical Support at 800.279.9404. Turn off icemaker if filtered water goes to icemaker.

#### **...From fittings**

1. Relieve pressure by turning off water supply to the filter opening until water and airflow stops.

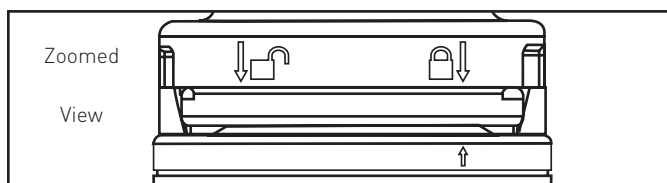
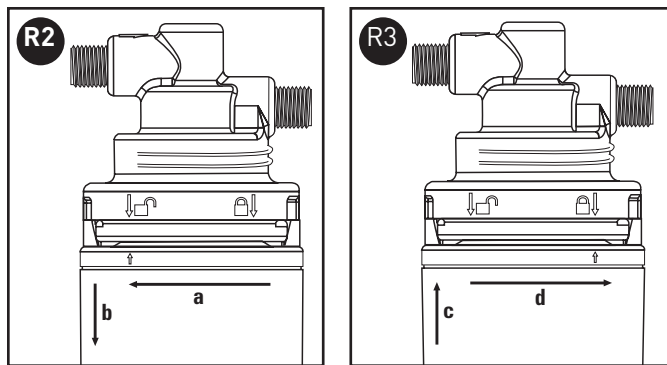

2. For copper or plastic tubing, loosen the compression nut and pull the tubing from the brass fitting.
3. Inspect to see if the ferrule and insert (plastic only) are properly installed on the tubing.
4. If so, reconnect tubing finger-tight, then tighten nut about 1 to 1-1/2 turn(s) with a wrench.
5. Install cartridge and turn on water supply, if it still leaks, contact Technical Support at 800.279.9404. Turn off icemaker if filtered water goes to icemaker.

## **MAINTENANCE**

Contact your local water treatment professional for replacement cartridge pricing or call Customer Service at 800.279.9404 for a dealer near you.

## **REPLACEMENT PARTS**

Part No.	Model No.	Description	Replacement for
144842	QCH	Head Assembly	1/4-inch Male Threaded Ports
257438	QCH-1/4PF	Head & Bracket Assembly	1/4-inch John Guest Push Fit
257439	QCH-3/8PF	Head & Bracket Assembly	3/8-inch John Guest Push Fit
144846		1/4-inch MT Hardware Kit	1/4-inch Male Threaded Ports
244430	QC-PF	Push Fit Hardware Kit	John Guest Push Fit

## PERFORMANCE DATA

**Important Notice:** Read this performance data and compare the capabilities of these systems with your actual water treatment needs. It is recommended that, before installing a water treatment system, you have your water supply tested to determine your actual water treatment needs.

These systems have been tested according to NSF/ANSI 42 and 53 for the reduction of the substances listed below. The concentration of the indicated substances in water entering the system was reduced to a concentration less than or equal to the permissible limit for water leaving the system as specified in NSF/ANSI 42 and 53.

**⚠ WARNING:** Do not use with water that is microbiologically unsafe or of unknown quality without adequate disinfection before or after the system.

### QC10-CBR WITH QC10-CBRR CARTRIDGE

Substance	Influent Challenge Concentration	Max. Permissible Product Water Concentration	Reduction Requirements	Minimum Reduction	Average Reduction
Standard 42—Aesthetic Effects					
Chlorine	2.0 mg/L ± 10%		≥ 50%		97.5%
Particulate, Class I Particles 0.5 - 1 µm	at least 10,000 particles/mL		≥ 85%		98.4%
Standard 53—Health Effects					
Lead [pH 6.5]	0.15 mg/L ± 10%	0.010 mg/L			99.3%
Lead [pH 8.5]	0.15 mg/L ± 10%	0.010 mg/L			99.5%
Atrazine	0.009 mg/L ± 10%	0.003 mg/L			92.0%
Lindane	0.002 mg/L ± 10%	0.0002 mg/L			99.0%

Flow Rate = 0.5 gpm (1.9 L/min)

Capacity = 500 gallons (1,890 L) or 6 months

### QC10-GAC WITH QC10-GACR CARTRIDGE

Substance	Influent Challenge Concentration	Max. Permissible Product Water Concentration	Reduction Requirements	Minimum Reduction	Average Reduction
Standard 42—Aesthetic Effects					
Chlorine	2.0 mg/L ± 10%		≥ 50%		82.0%

Flow Rate = 0.5 gpm (1.9 L/min)

Capacity = 500 gallons (1,890 L) or 6 months

### QC10-EP WITH QC10-EPR CARTRIDGE

Substance	Influent Challenge Concentration	Max. Permissible Product Water Concentration	Reduction Requirements	Minimum Reduction	Average Reduction
Standard 42—Aesthetic Effects					
Chlorine	2.0 mg/L ± 10%		≥ 50%		95.8%

Flow Rate = 0.5 gpm (1.9L/min)

Capacity = 1,500 gallons (5,670 L) or 9 months

Testing was performed under standard laboratory conditions; actual performance may vary.

### Test Conditions:

Flow Rate	= 0.5 gpm (QC10-CBR & QC10-EP)
	= 0.75 gpm (QC-GAC)
Inlet Pressure	= 60 psi (4.1 bar)
pH	= 7.5 ± 1
Temperature	= 68°F ± 5°F (20°C ± 2.5°C)

### Operating Requirements:

Pressure	= 30-125 psi (2.1-8.62 bar)
Temperature	= 40°-100°F (4.4°-37.8°C)

### California Residents - Proposition 65

**⚠ WARNING:** This product contains chemicals known to the State of California to cause cancer or birth defects or other reproductive harm.



The QC10-CBR is Tested and Certified by NSF International against NSF/ANSI Standard 42 and 53 for the reduction of claims specified on the performance data sheet.



The QC10-EP and QC10-GAC are Tested and Certified by NSF International against NSF/ANSI Standard 42 for the reduction of claims specified on the performance data sheet.





For Pentair® Product Warranties visit:  
Pentair para las garantías de los productos visite: } [waterpurification.pentair.com](https://www.waterpurification.pentair.com)  
Pour Pentair garanties produit visitez le site :



13845 BISHOPS DR., SUITE 200, BROOKFIELD, WI 53005  
WATERPURIFICATION.PENTAIR.COM | CUSTOMER CARE: 800.279.9404 | tech-support@pentair.com

© 2018 Pentair Residential Filtration, LLC. All rights reserved.

§For a detailed list of where Pentair trademarks are registered, please visit [waterpurification.pentair.com/brands](https://www.waterpurification.pentair.com/brands). Pentair trademarks and logos are owned by Pentair plc or its affiliates. Third party registered and unregistered trademarks and logos are the property of their respective owners.

146224 REV J JA18