

FRESHPOINT[®] F3000

THREE STAGE FILTRATION SYSTEMS



F3000-B2M, (with filter life monitor) shown

APPLICATIONS

- ◆ Drinking water

FEATURES • BENEFITS

- ◆ Effortless click-in cartridge change-outs
- ◆ Color-coded cartridges help maintain proper filter sequence
- ◆ 3/8" push fittings for easy installation
- ◆ Optional remote cartridge timer provides visual filter replacement notification (*Model F3000-B2M only*)

MODELS

- ◆ F3000-B2B
- ◆ F3000-B2M (Includes filter life monitor)

INSTALLATION TIPS

- ◆ Choose a mounting location suitable to support the full weight of the system when operating.
- ◆ Install vertically with the cartridge hanging down.
- ◆ System may be installed with cartridge flush to the baseboard if desired as the mechanical assist lever pushes cartridges straight out.
- ◆ Magnetic timer may be removed from system and placed in alternative locations such as on refrigerator.

OPERATION TIPS

- ◆ Replace cartridge every 675 gallons or 1 year (or if flow has diminished).
- ◆ System designed with integrated check valves so cold water line does not need to be shut-off to perform cartridge change-outs.

INCLUDES

- ◆ Side faucet
- ◆ Installation kit
- ◆ Installation and operation manual

FRESHPOINT THREE STAGE FILTRATION SYSTEMS

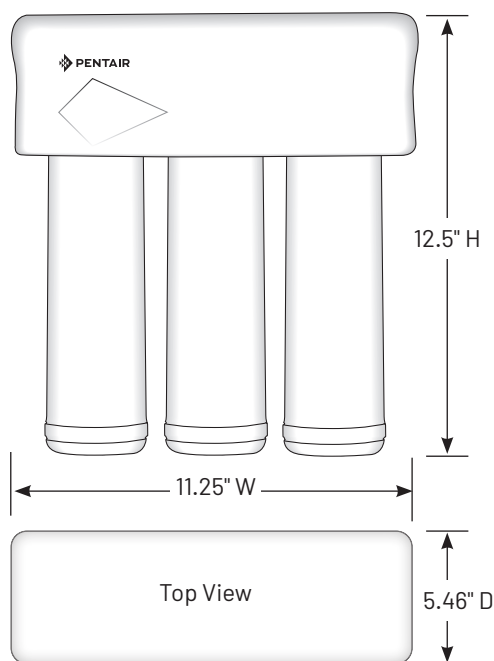

SPECIFICATIONS

- ◆ **System** (Model/Part No.)
F3000-B2M/158854
F3000-B2B/158840
- ◆ **Inlet Size**
3/8" QC
- ◆ **Dimensions**
12.5" H x 11.25" W x 5.46" D
(317 mm x 285 mm x 139 mm)
- ◆ **System Weight**
6 lbs
- ◆ **Contaminant Reduction**
Chlorine Taste & Odor, Lead, Atrazine, Lindane, Nominal Particulate, Class I, VOC's, Cyst: NSF/ANSI Standard 53 certified to reduce cysts such as *Cryptosporidium* and *Giardia* by mechanical means.
- ◆ **Micron Rating**
0.50
- ◆ **Approximate Filter Life***
Up to 1 Year
- ◆ **Capacity**
675 Gallons (2555.15 liters)
- ◆ **System Production Rate**
0.60 gpm (2.27 Lpm)
(Side Faucet Required)
- ◆ **Certifications**
NSF/ANSI Standard 53
CSA Standard B483.1
- ◆ **Feed Pressure Range**
40 - 100 psi (2.75 - 6.89 bar)
- ◆ **Temperature Range**
40 - 100°F (4.4 - 37.8°C)
- ◆ **Replacement Cartridges**
(Model/Part No.)
F1S5-RC/655116-96
F2B2-RC/655126-96 (twin pack)

* Filter life dependent on gallon usage and overall incoming water quality.

EPA Est. No. 082989-CHN-001



13845 Bishops Dr. | Suite 200 | Brookfield, WI 53005 | United States
P: 262.238.4400 | Customer Service: 800.279.9404 | tech-support@pentair.com | pentair.com

§For a detailed list of where Pentair trademarks are registered, please visit www.pentair.com/registrations. Pentair trademarks and logos are owned by Pentair plc or its affiliates. Third party registered and unregistered trademarks and logos are the property of their respective owners.

© 2020 Pentair Residential Filtration, LLC. All rights reserved.

4004686 Rev C FE20



System Tested and Certified by NSF International against CSA B483.1 and NSF/ANSI Standard 53 for the reduction of Lead and Cyst.