

Model 255 Strainer Installation and Maintenance

Screw strainer directly to pump in direction of arrow.

Disassembly and Cleaning:

- (1) Turn off power to pump
- (2) Drain water from system. Close any valves
- (3) Unscrew bowl counterclockwise
- (4) Remove bowl and screen to clean
- (5) Check all parts. Replace if bad

To Reassemble:

- (1) Place screen in top
- (2) Place gasket in bowl
- (3) Screw bowl to top clockwise

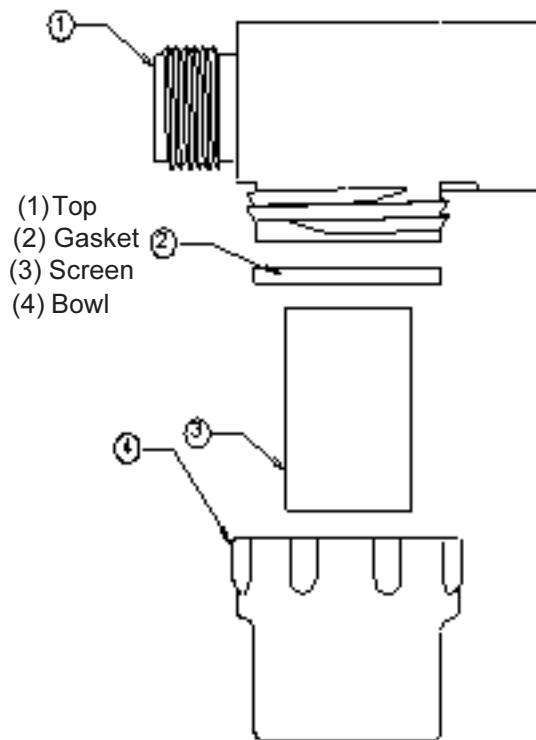

LIMITED WARRANTY

SHURflo warrants its 255 series Strainers to be free from defects in materials and workmanship (under normal use and service) for a period of one year from the date of manufacture or one (1) year of use with proof of purchase. In no case will the terms of this warranty extend beyond two (2) years of manufactured date.

This limited warranty will not apply to any SHURflo product that is improperly installed, misapplied, or incompatible with components not manufactured by SHURflo. SHURflo will not warrant any product which is modified or damaged outside the SHURflo factory.

SHURflo's obligation under this warranty policy is limited to replacing or repairing (whichever it deems advisable) any such product or part which is returned to SHURflo's factory with transportation charges prepaid and which, upon SHURflo's inspection is found defective under the terms of this warranty.

Refer to SHURflo Service Bulletin #1047 for complete details of this limited warranty.

SHURflo
5900A Katella Ave.
Cypress, CA 90630
(562) 795-5200
(800) 854-3218
FAX (562) 795-7564
Shipping: 5900C
Katella Ave.
Cypress, CA 90630

SHURflo East
52748 Park Six Court
Elkhart, IN 46514-5427
(574) 262-0478
(800) 762-8094
FAX (574) 264-2169
<http://www.shurflo.com>

SHURflo Ltd.
Unit 5 Sterling Park
Gatwick Road, Crawley
West Sussex, RH10
2QT
United Kingdom
+44 1293 424000
FAX +44 1293
421880