



# SHURFLO RAW WATER STRAINER

## PRODUCT TECHNICAL DATA SHEET

OEM: 253-320-00  
 AFTERMARKET: 253-320-01



SHURflo's family of Raw Water Strainers are built to keep your bait tank, Livewell and Wash down pumps protected from harmful debris. The Raw Water Strainer features a clear twist off bowl and removable stainless steel screen, which allows for easy inspection and cleaning. An integral o-ring creates a tight seal, eliminating possible leaks. Keep your pumps and components lasting longer by protecting them with the SHURflo Raw Water Strainer.

**APPLICATION:**

Raw water pump debris strainer. Vacuum side only

**MATERIALS OF CONSTRUCTION:**

Gasket: Buna  
 Housing: White Nylon  
 Bowl: Clear Nylon  
 Screen: 50 Mesh Type 304 SST

**SPECIFICATIONS:**

Inlet Port: 1" NPT-F  
 Outlet Port: 1" NPT-F  
 Max. Temp: 120°F [48°C]  
 Max. PSI: Vacuum Side Only

**SHIPPING INFORMATION:**

Approx. Net Weight: 0.4 lbs. [3.4 Kg] ea.  
 Carton Qty.: 12  
 Approx. Carton Weight: 6 lbs.

**RELATED DOCUMENTS:**

Catalog: MS-030-140  
 App Guide Sheet: MS-020-005  
 Installation Manual: N/A

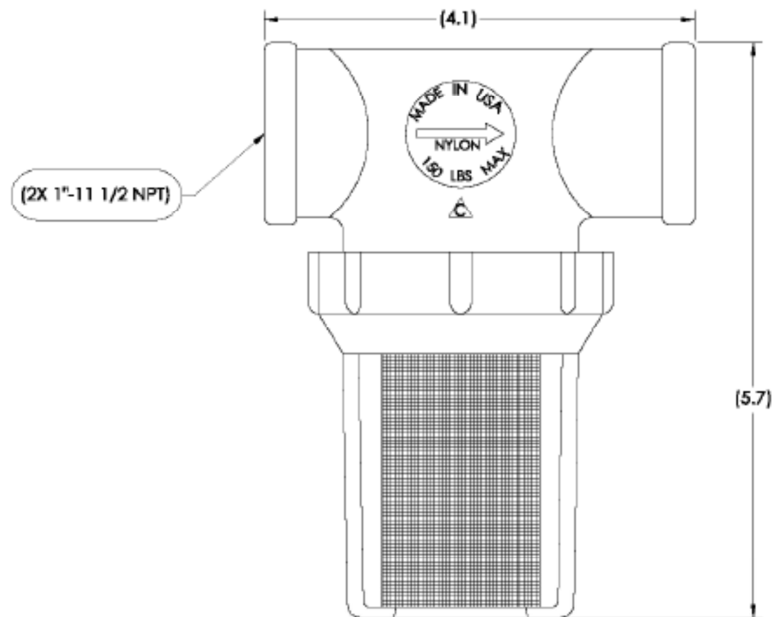

**Repair Kits**

Number	Description	Part Number
1	Screen	94-726-00

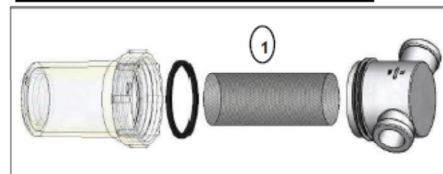

**WATER PURIFICATION**

3545 Harbor Gateway South, Suite 103, Costa Mesa, CA 92626, (800) 854-3218 www.SHURFLO.com

All Pentair trademarks and logos are owned by Pentair, Inc. All other brand or product names are trademarks or registered marks of their respective owners. Because we are continuously improving our products and services, Pentair reserves the right to change specifications without prior notice. Pentair is an equal opportunity employer.