

SHURFLO Industrial Product Limited Warranty

SHURflo Industrial series pumps and products are warranted to be free of defects in material and workmanship under normal use, for a period of one (1) year from the date of manufacture, or one (1) year of use, with proof of purchase. This limited warranty will not exceed two (2) years, in any event. The limited warranty will not apply to pumps/products that were improperly installed, misapplied, damaged, altered or are incompatible with fluids or

components not manufactured by SHURflo. All industrial pumps/products must be flushed of any chemicals before shipping*. All warranty considerations are governed by SHURflo's written Return Policy. Returns are to be shipped postage prepaid to either service center; SHURflo's office in Elkhart, IN. SHURflo shall not be liable for freight damage incurred during shipping. Package returns carefully. SHURflo's obligation under this

warranty policy is limited to the repair or replacement of the pump/ product. All returns will be tested per SHURflo factory criteria. Products found not defective (under the terms of this limited warranty) are subject to charges paid by the returnee for the testing and packaging of "tested good" non-warranty returns. No credit or labor allowances will be given for pumps or products returned as defective. Warranty replacements will be shipped

on a freight allowed basis. SHURflo reserves the right to choose the method of transportation. This limited warranty is in lieu of all other warranties, expressed or implied, and no other person is authorized to give any other warranty or assume obligation or liability on SHURflo's behalf. SHURflo shall not be liable for any labor, damage or other expense, nor shall SHURflo be liable for any indirect, incidental or consequential damages of any kind

incurred by the reason of the use or sale of any defective product or part. This limited warranty covers industrial products distributed within the United States of America. Other world market areas should consult with the actual distributor for any deviation from this document.

Return Policy

All industrial pumps/products must be flushed of any chemical (ref. OSHA Section 1910.1200 (d)(6)(f)(g)(h)) and hazardous chemicals must be labeled / tagged before being shipped* to SHURflo for service or warranty consideration. SHURflo reserves the right to request a Material Safety Data Sheet from the returnee for any pump/product it deems necessary. SHURflo reserves the right to "disposition as scrap" pumps/products returned which contain unknown fluids. SHURflo reserves the right to charge the returnee for any and all costs incurred for chemical testing, and proper disposal of components containing unknown fluids. SHURflo requests this in order to protect the environment and personnel from the hazards of handling unknown fluids.

Carriers, including U.S.P.S., airlines, UPS, ground freight, etc., require specific identification of any hazardous materials to be shipped. Failure to do so may result in a substantial fine and/or prison term. Check with your shipping company for specific instructions.

SHURflo reserves the right to update specifications, prices, or make substitutions.



SHURFLO

3545 Harbor Gateway South, Ste. 103, Costa Mesa, CA 92626, (800) 854-3218 www.shurflo.com

SHURFLO Europe, Middle East, Africa

Pentair Water Belgium bvba, Industriepark Wolfstee, Toekomstlaan 30, B-2200 Herentals, Belgium, +32-14-283500

All Pentair trademarks and logos are owned by Pentair, Inc. All other brand or product names are trademarks or registered marks of their respective owners. Because we are continuously improving our products and services, Pentair reserves the right to change specifications without prior notice.

Pentair is an equal opportunity employer.

911-992 Rev C 07/12 ©Pentair, Inc. All rights Reserved.



SHURFLO

Model 1100 Series General Utility Transfer Pump Installation and Operation Manual

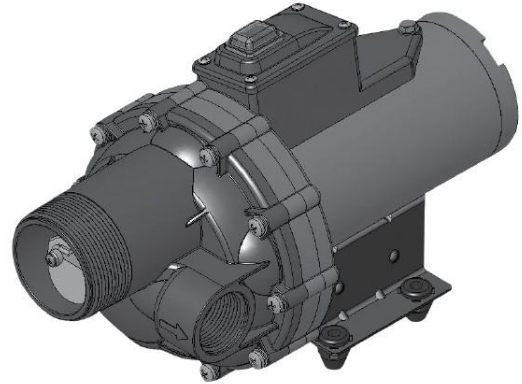

Description

The SHURflo 1100 Series is a General Utility Transfer Pump designed for intermittent duty only. Never use for operational pressure above 20 psi. or spraying applications. The information outlined by this manual is general and is not meant to be absolute. Be certain the pump materials will be compatible with the fluid being pumped. If unsure of the chemical compatibility with the pumps materials or the motor's intended design, please call SHURflo for assistance.

CAUTION

DO NOT use to pump flammable liquids. Never operate the pump in an explosive environment. Arcing from the motor brushes or excessive heat from an improperly cycled motor may cause an explosion.

WARNING

DO NOT assume fluid compatibility. If the fluid is improperly matched to the pump's elastomers, a leak may occur. Pumps used to transfer hazardous or hot (max. temperature 130°F [54.4°C]) chemicals must be in a vented area to guard against the possibility of injury due to harmful or explosive liquid/vapors.

CAUTION

DO NOT operate the pump at pressures or voltages which cause the motor to exceed the ampers rating indicated on the name plate. Make an allowance for environmental conditions or operational parameters, which could cause external temperature of the motor to exceed 190°F [48°C]. Operating the pump beyond the indicated ratings will cause the motor to trigger the internal thermal device.

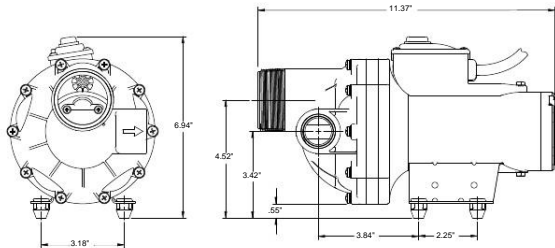
**Flow / Amp Data**

PSI	GPM	LPM	AMPS
Open	10.7	40	9.3
5	10.1	38	10.3
10	8.7	33	12.3
15	7.6	29	13.9

* Based on water; 3ft inlet lift (12.7 VDC)

Features

- 12.7 VDC Recommended (±10%) / Maximum Amps 15.0.
- 12' Power Cord with Inline Fuse and Battery Clips.
- Integral Thermal Breaker (auto reset).
- Self-priming – Positive-displacement.
- Ability to Handle High Viscosity Liquids (up to 850 cps).
- 5-Chamber Diaphragm Design with Co-Molded Pistons for Increased Durability.
- Integral Over-Pressure Protection from Inadvertent Dead head Operation.
- Inlet Port: 2-inch Male-NPT.
- Discharge Port: 1-inch Female-NPT.

Materials of Construction

Upper Housing	Polypropylene
Valve Housing	Polypropylene
Valves (1100-7XX-XXX)	EPDM
Valves (1100-5XX-XXX)	Viton®
O-ring	Viton®
Diaphragm	Santoprene-
Lower Housing	Aluminum (not in fluid path)
Pumphead Screws	Stainless Steel (not in fluid path)

Installation

1. Be sure to use Teflon® tape for any and all plumbing connections made to the pump.
2. SHURflo recommends that barb port fitting and flexible tubing be used for inlet/outlet ports connection. The use of flexible tubing will minimize stress and vibration that could, in time, loosen pump hardware or attribute to cracking of plastic housings.
3. Connect appropriate size and length of tubing for current application. Length and size of tubing used will cause backpressure (restriction) depending on the viscosity of the fluid pumped. Choose tubing type based on chemical compatibility and distance required.
4. Ensure all connections are tight and barbed hose connections properly clamped.

WARNING

Care should be used when installing the (front) inlet fitting. Be sure to grasp and hold the pumphead (not the motor) when tightening the fitting.

5. Install an appropriate sized inlet strainer with 50-mesh screen to the inlet of the pump to prevent debris from entering the system.
6. Ensure the power switch on the pump is in the OFF position.
7. Connect the Battery Clips to the appropriate connections to provide power to the system.

Note: The RED wire is the positive (+) 12-Volt connection. The BLACK wire is the negative (-) 12-Volt connection.

CAUTION

12-Volt Batteries can present a hazardous, explosive environment. Before making any Battery connections, assure pump switch is in the off position, assure pump's Battery connections are tight before operating pump.

8. Once the system is ready, turn the power switch to the ON position.
10. Once pump operation is complete, always turn the power switch to the OFF position.

Flushing

If pump is to not be used for an extended period of time, it is suggested to flush any chemicals from the pump with fresh water. Flushing the pump will ensure a long, problem-free life and easy start-up when the pump is needed again.

Note: DO NOT flush with petroleum-based chemicals. Use only water to flush the pump. Be sure to properly dispose of the contaminated rinse water used to flush the pump.

Troubleshooting**Pump Will Not Start:**

- 4 Inline Fuse
- 4 For correct voltage (±10%) and electrical connections
- 4 Motor for open or grounded circuit
- 4 Check wire connections at switch and switch operation
- 4 For locked drive assembly

Will Not Prime: (No discharge/motor runs)

- 4 Product level low
- 4 Inlet for debris
- 4 Inlet plumbing joints for good seal or vacuum leak
- 4 Proper voltage with the pump operating (±10%)
- 4 Outlet tube severely restricted (kinked)
- 4 Pump housing for cracks
- 4 Pump for loose screws
- 4 Debris in pump inlet/outlet valves

Leaks

- 4 Loose screws
- 4 Diaphragm ruptured, pinched or punctured

Noisy / Rough Operation

- 4 For loose pump head or drive screws

Parts List

Item	Kit part no.	Description
(1)	94-718-00	Motor Assembly Kit
(2)	94-719-00	Diaphragm/Lower Housing/ Drive Assembly Kit
(3a)	94-720-00	Valve Housing Assembly Kit (EPDM)
(3b)	94-720-05	Valve Housing Assembly Kit (Viton®)
(4)	94-721-00	Upper Housing Assembly Kit

