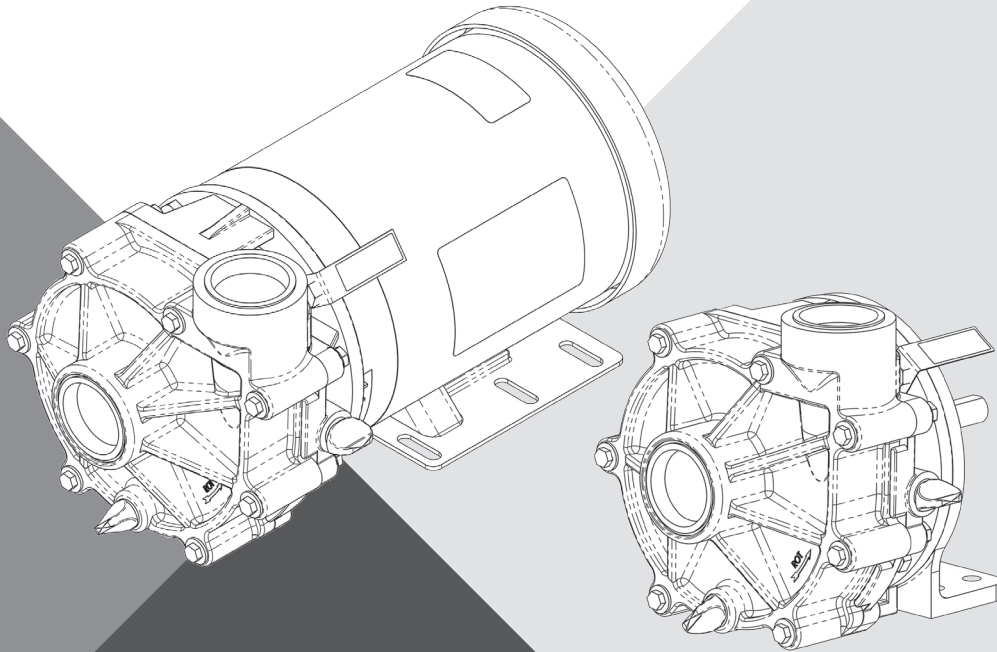




# Corrosion-Resistant Close-Coupled Centrifugal Pumps

Noryl® Series and Polypropylene Series



## INSTALLATION AND OPERATION MANUAL

[pentair.com](http://pentair.com)

# TABLE OF CONTENTS

---


<b>SECTION.....</b>	<b>PAGE</b>
Safety Information .....	3
General Information.....	4
Maintenance .....	5
Model Codes & Options .....	7
Performance & Specifications .....	8
Dimensions.....	10
Parts List.....	11
Troubleshooting .....	16
Warranty.....	19


\* NORYL is a registered trademark of General Electric Company.


# SAFETY INFORMATION


---

## SAFETY SYMBOLS

 This is the safety alert symbol. When you see this symbol on your pump or in this manual, look for one of the following signal words and be alert to the potential for personal injury:

 **DANGER** warns about hazards that will cause serious personal injury, death or major property damage if ignored.

 **WARNING** warns about hazards that can cause serious personal injury, death or major property damage if ignored.


 **CAUTION** warns about hazards that will or can cause minor personal injury or property damage if ignored.

The word **NOTE** indicates special instructions that are important but not related to hazards.

## PACKAGING INSPECTION

When the unit is received, look for any product damage as you unpack the item. If any damage is present or parts are missing, do not attempt to operate pump. Use this manual to determine that all parts are properly installed. If you are in doubt, do not operate the pump.

### CALIFORNIA PROPOSITION 65 WARNING:


 **WARNING** This product and related accessories contain chemicals known to the State of California to cause cancer, birth defects or other reproductive harm.

## GENERAL SAFETY

- ♦ Carefully read and follow all safety instructions in this manual and on the unit itself. Failure to comply with the safety instructions could result in personal injury and/or property damage!
- ♦ Read this manual's operating instructions carefully before attempting to assemble, install, operate and/or maintain the product described. The pump application, limitations, and potential hazards must be known.
- ♦ Follow all applicable local and state codes and regulations.
- ♦ Keep safety labels in good condition, replacing any missing or damaged labels. Retain these instructions for future use.
- ♦ Do not use to pump flammable or explosive fluids such as gasoline, fuel oil, kerosene, etc. Do not use in flammable and/or explosive atmospheres. When pumping hazardous or dangerous materials, use only in room or area designated for that purpose.
- ♦ For your protection, always wear proper clothing, eye protection, etc. in case of any malfunction.
- ♦ For proper handling techniques and cautions, contact your chemical supplier, insurance company and local agencies (fire dept., etc.). Failure to comply with this warning could result in personal injury and/or property damage.

- ♦ Release all pump and line pressure within the system before servicing any component.
- ♦ Drain liquids from the system before inspecting or servicing. If liquids are hazardous, handle environmentally and safely.
- ♦ Secure the discharge line before starting the pump. An unsecured discharge line will whip, possibly causing personal injury and/or property damage.
- ♦ Make certain that all connections are secure. Check piping and hoses for weak or worn condition before each use.
- ♦ Do not smoke or use devices that can generate sparks in a septic (gaseous) environment.
- ♦ Do not install pump in any location classified as hazardous by National Electrical Code, ANSI/NFPA 80-1984 or the Canadian Electrical Code.
- ♦ Pumps are not self-priming and cannot suction lift, flooded inlet is required. If inlet is not flooded when the pump is running, seal failure will result which is not covered under the manufacturer's warranty.
- ♦ For pumps whose discharge line can be shut off or obstructed, provide a means of pressure relief.
- ♦ The motor is designed to be used in a clean, dry location with access to an adequate supply of cooling air. Ambient temperature around the motor should not exceed 104°F (40°C). For outdoor installations, motor must be protected by a cover that does not block airflow to and around the motor. This unit is not waterproof and is not intended to be used in showers, saunas, or other potentially wet locations. This unit is not weatherproof nor is it able to be submersed in water.

## ELECTRICAL SAFETY

 **DANGER HAZARDOUS VOLTAGE. CAN SHOCK, BURN, OR KILL.** When installing, operating, or servicing this pump, follow the safety instructions listed below.

- ♦ **DO NOT** allow the plug on the end of the electrical cord to be submerged.
- ♦ Ensure that the power source conforms to the requirements of your equipment.
- ♦ Disconnect power before inspecting or servicing. If the power disconnect is out of sight, lock in the open position and mark or tag it to prevent unexpected application of power. Failure to do so could result in fatal electric shock!
- ♦ Connect the pump according to the NEC or CEC and local codes. Follow all OSHA safety codes .

# GENERAL INFORMATION

---

## OVERVIEW

SHURflo close-coupled, non-metallic pumps produce high flow rates under moderate head conditions.

Designed for continuous medium pressure circulation and transfer of nonflammable liquids, booster service, spraying systems, jockey pump service, aggressive liquid applications, and other general purpose pumping compatible with pump component materials where no suction lift is required. A water seal flush port is provided for the decontamination of chemicals on the seal and seat elastomers. Shurflo pumps are not designed to be used as clean water pumps as defined in 10CFR Parts 429 and 431.

Additional features include:

- ◆ Capacities to 110 GPM, heads to 95 ft.
- ◆ 1/3 to 3 HP AC (and use 3450 rpm NEMA 56J frame motors with base).
- ◆ Discharge can be rotated in 90-degree intervals.
- ◆ All pumps have 1/2" female NPT inlet and outlet ports.
- ◆ Standard pump models (at 3450 RPM) will handle specific gravities to 1.1 (at 100 SSU or less). For specific gravities to 1.4 (at 100 SSU or less), increase motor HP by one size but not to exceed standard 3 HP motor at 3450 RPM or 65 in.-lbs. of torque maximum. Higher specific gravity fluids are not recommended.  
  
For viscosity up to 400 SSU (specific gravity of 1.0 or less), increase motor HP by one size but not to exceed standard 3 HP motor at 3450 RPM or 65 in.-lbs. of torque.  
  
For fluids with a viscosity greater than 400 SSU, pump speed must be reduced below 3450 RPM.
- ◆ Standard pump models (at 3450 RPM) will handle viscosity to 100 SSU (at 1.1 specific gravity or less) and up to 200 SSU (specific gravity of 1.0 or less).  
  
For viscosity up to 400 SSU (specific gravity of 1.0 or less), increase motor HP by one size but not to exceed standard 3 HP motor at 3450 RPM or 65 in.-lbs. of torque.  
  
For fluids with a viscosity greater than 400 SSU, pump speed must be reduced below 3450 RPM.
- ◆ Single-phase motors are equipped with thermal overload protection. Overload protection is not supplied on three-phase units and must be provided in starter units.
- ◆ Shurflo complete Pedestal models are also available. Pedestal mount models feature a 5/8" diameter, 316 stainless steel solid shaft, a corrosion-resistant coated cast iron bearing housing and a double row of sealed ball bearings.  
  
They may be either long coupled or pulley driven with any base-mounted motor such as ODP, TEFC or wash-down motors.

**NORYL SERIES:** This series is designed for industrial chemical applications configured with TEFC (totally-enclosed fan-cooled) motors. The pumps are made of Noryl, which is non-metallic, chemical-resistant to most acids, alkalis, and inorganic solvents. This material is stiffer under pressure and temperature than the Polypropylene series. The Noryl series handles inlet booster pressures to 30 psi and a maximum temperature of 180° F. These pumps are equipped with a unique chemical-resistant carbon ceramic mechanical seal with Viton elastomer having the stainless steel components sealed in Noryl allowing for a complete non-metallic Noryl wet end. This unique seal guarantees reliability through simplicity and balance of design. Even the motor and pedestal drive shaft is protected by the seal design.

**POLYPROPYLENE SERIES:** The pumps are made of non-metallic, glass-filled polypropylene construction offering chemical resistance to most acids, alkalis, and inorganic solvents as does the Noryl series. The difference is these pumps are equipped with a carbon ceramic mechanical seal with Buna-N elastomers with the stainless steel components that are not sealed, but still protect the motor or pedestal shaft from chemical exposure. The Polypropylene series cannot handle added inlet booster pressures and is rated for a maximum temperature of 140° F. However, upgraded chemical-resistant, polypropylene-encased seals are available.

**REPAIR SEALS AND OPTIONS:** Standard and upgraded seals are available for both the Noryl and Polypropylene pumps. If abrasive or small, particulated fluids are being pumped, upgrading to either the encased Noryl or polypropylene silicon carbide mechanical seal with Viton elastomers is recommended. Standard and upgraded seals can be located on the repair parts list pages in this manual.

**PUMP HEADS AND PEDESTAL MOUNT BASE:** Complete pump heads and pedestal base can be ordered. Pump head and pedestal base model numbers are called out in the repair parts list pages of this manual.

# MAINTENANCE

---

## MAINTENANCE

**⚠ WARNING** Make certain that the unit is disconnected from the power source before attempting to service or remove any components!

**REMOVAL OF OLD SEAL ASSEMBLY:** Should the mechanical seal (Ref. No. 5) require repair, proceed as follows and refer to Figures No. 2, 3 & 4. **NOTE:** Always replace both the seal seat and seal as an assembly to ensure proper mating of components.

1. Remove bolts (Ref. No. 8) connecting the pump housing (Ref. No. 2) to the body adapter (Ref. No. 1).
2. Remove the pump housing casing (Ref. No. 2).
3. Care should be taken not to pinch or "shave" the O-Ring gasket (Ref. No. 6) between the body adapter and the housing.
4. Remove the impeller (Ref. No. 4) from the motor shaft by unscrewing it counterclockwise as viewed from the motor face.
5. Motor shaft must be held in place to remove impeller. Back of the motor either has slot in shaft (use large screwdriver to hold) or has 2 flats on motor shaft (use 7/16" open end wrench to hold).
6. Unscrew impeller (Ref. No. 4) CCW when looking at the front of the pump.
7. The ceramic seat is located on the back side of the impeller (part of Ref. No. 5). Pry the seat out by using a screwdriver in the inside hole (see Figure 2). Be careful not to damage or scratch the inside surfaces of the bore holding the seat. Such scratches can cause leaks. Replace the impeller if such damage occurs.
8. Remove the motor body adapter (Ref. No. 1) from the motor by removing the adapter bolts.
9. Use a wooden dowel to push out the mechanical seal (part of Ref. No. 5) from the body adapter (Ref. No. 1) (see Figure 2). Do not dig the seal out from the front.

## INSTALLATION OF NEW SEAL ASSEMBLY

The precision carbon/ceramic faces on the mechanical seal are easily damaged. Handle your repair seal carefully. Do not touch the carbon/ceramic seal faces.

**NOTE:** Be sure that shaft shoulder does not damage carbon face.

1. Thoroughly clean all surfaces of the seal cavity in body adapter (Ref. No. 1).
2. Replace the O-Ring inside the cavity (Ref. No. 11). Using seal installation tool (see Figure 3), press in new mechanical seal being careful not to scratch the polished carbon face.
3. Wet the rubber portion of the new seal seat (part of Ref. No. 5) with a light coating of soapy water. While wearing clean gloves or using a clean light rag, press seal seat squarely into impeller recess. Use the cardboard washer (usually supplied with new seal) to place over the polished ceramic surface and use a piece of pipe or dowel rod to press in firmly but gently (see Figure 2). Avoid scratching the ceramic face, usually white.
4. Dispose of cardboard washer. Check again to see that ceramic surface is free of dirt and all other foreign particles and that it has not been scratched or damaged.
5. Install the motor body adapter (Ref. No. 1) to the motor using bolts. Be careful not to damage the seal when sliding over the motor shaft.
6. Screw impeller (Ref. No. 4) onto shaft. Use screwdriver slot at rear of motor shaft (opposite the threaded end) to tighten impeller to 150 in-lbs. of torque (see Figure 2).

A short "run-in" period may be necessary to provide completely leakproof seal operation.

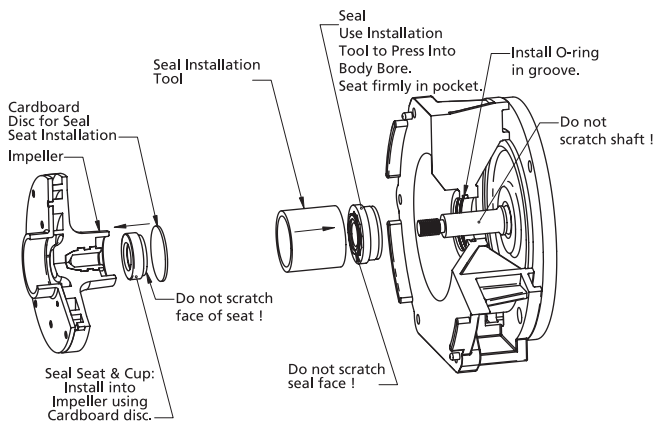
This completes the seal installation. It may be necessary to remove plug in motor end cap to expose slot. If removed, be sure to reinstall plug AFTER pump is completely assembled.

- ◆ Check if shaft turns freely by spinning impeller. If rubbing or binding is found, remove impeller.
- ◆ Place o-ring (Ref. No. 6) into groove on back side of housing. It may be necessary to temporarily hold the o-ring in the groove with grease.
- ◆ Seal assembly will produce minor drag when spinning motor shaft, but rubbing anywhere else must be eliminated! Otherwise, damage to pump and/or motor may occur.

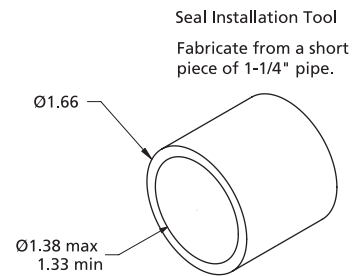
# MAINTENANCE

## Water-Flushed Seals

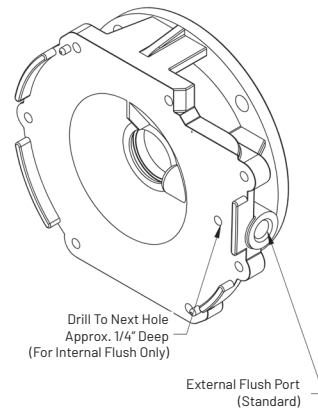
1. Water-flushed seals are recommended for abrasive solutions, high temperature service, or when pumps may be run dry or against deadhead conditions.
2. When conditions cause the pumped liquid to form crystals, or if the pump remains idle for a period of time without adequate flushing, a water-flush seal system is advised.
3. The water flush will provide decontamination of chemicals on elastomers and seal and seat faces, while providing lubrication required for start-up. Two (2) methods of water flush can be used:
  - ◆ Direct Plumbing to City Water: This provides the best possible approach to flushing the seal and seat faces. Caution must be taken to conform to local city ordinances that may require backflow preventers. These are a series of check valves required to prevent contamination of city water if the water supply is shut off. Also be aware of the addition of water into the chemicals pumped where some imbalance may be created, altering the chemical's formulation and aggressiveness.
  - ◆ The flush port is provided on the side of the pump below the discharge (Figure 4).
  - ◆ Recirculation of Solution Pumped: This system takes a bleed off the pump discharge and recirculates the solution in the seal chamber. Although not nearly as effective as the direct water flush, it will provide cooling to the seal and seat faces under operation. This system is not effective where crystallization occurs or for pumps in idle conditions.
  - ◆ For internal recirculation to seal, drill the recess plug on the pump body located at 3 o'clock with a 1/8" drill.
4. Always drain and flush the pump before servicing, disassembling for any reason or returning the unit for repair.
5. Never store pumps containing hazardous chemicals.
6. Before returning the pump for service/repair, drain out all liquids and flush the unit with a neutralizing liquid. Then, drain the pump. Attach a tag or include a written notice certifying that this has been done. Please note that it is illegal to ship or transport any hazardous chemicals without United States Environmental Protection Agency licensing.



**Figure 2 - Seal Install**

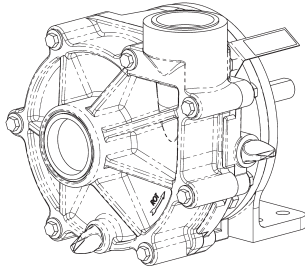


**Figure 3 - Seal Install Tool**

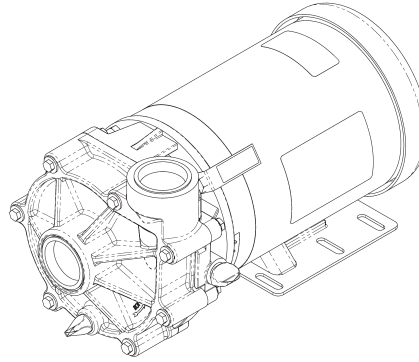


**Figure 4 - Flush Port**

# MODEL CODES AND OPTIONS



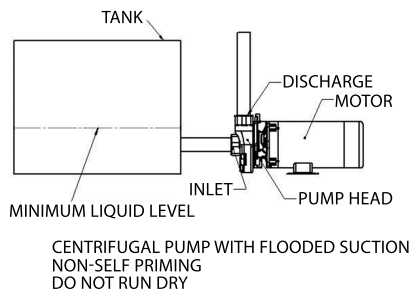
P = Pedestal



M = Motor (with base)

Example Model: CHMPB44 (1 HP ODP motor with >1.15 Service Factor\*) or CHMPB45T (1.5 HP TEFC motor with 1.0 Service Factor\*)

1st	2nd	3rd	4th	5th	6th	7th	8th
Series	Mounting	Material	Seal** (Mech)	Impeller Sz. (NPT Ports)	Motor-Mounted Only		Impeller Type
					HP	AC Type	
CH: Centrifugal High Head Closed Impellers (Open Impellers Optional)	M: Motor (with base) P: Pedestal	N: Noryl P: Polypropylene	A: Viton (Noryl Encased) B: Buna-N (Stainless Steel Case) C: Viton (Polypropylene Case) (Silicon Carbide Seal / Seat Faces) N: Neoprene (Polypropylene Case) (Ni-Resist Seat) P: Viton (Polypropylene Case) V: Viton (Stainless Steel Case) X: Viton (Noryl Case) (Silicon Carbide Seal / Seat Faces)	1 (1½" - 1½") 2 (1½" - 1½") 3 (1½" - 1½") 4 (1½" - 1½") 5 (1½" - 1½") 6 (1½" - 1½")  To identify your impeller size, see chart in owner's manual.	1: 1/3 2: 1/2 3: 3/4 4: 1 5: 1½ 6: 2 7: 3  X: 56J Frame Motor "wet-end kit" Example: CHMNP1X	Blank: no code single phase ODP motor 3: 3 phase ODP motor T: 1 phase TEFC 3T: 3 phase TEFC	Blank: Closed O: Open Impellers (Polypropylene only)



**NOTE:** Not all order code combinations (configurations) are standard models available from the manufacturer. Custom model configurations may require ordering standard components and/or optional parts that will need to be assembled by the customer.

Manufacturer reserves the right to change model order codes, standard models, specifications and performance without notification.

(\*) ODP motors have > 1.15 service factors. Due to service factor, it is recommended TEFC motors are oversized by one HP increment.

Pedestal Pumps are not supplied with a motor.

(\*\*) Unless otherwise noted, seal faces are carbon on ceramic.

# PERFORMANCE & SPECIFICATIONS

## Performance – Standard Models (Water at 70°)

Model	HP**	3450 RPM Pump Driven Speed GPM of water at Total Head in Feet *								Max. Head
		10	20	30	40	50	60	70	80	
Noryl Models										
CHMNA1X	1/2	26	23	19	14	11	9	-	-	68
CHMNA2X	3/4	37	33	29	24	18	10	2	-	72
CHMNA3X	1	55	53	48	44	38	28	14	-	79
CHMNA4X	1½	85	78	73	66	59	50	41	21	89
CHMNA5X	2	96	89	83	77	68	58	47	31	91
CHMNA6X	3	123	115	106	97	86	76	63	48	95
Polypropylene Models										
CHMPB1X	1/3	26	23	19	14	11	9	-	-	68
CHMPB2X	1/2	37	33	29	24	18	10	2	-	72
CHMPB3X	3/4	55	53	48	44	38	28	14	-	79
CHMPB4X	1	85	78	73	66	59	50	41	21	89
CHMPB5X	1½	96	89	83	77	68	58	47	31	91
CHMPB6X	2	123	115	106	97	86	76	63	48	95

(\*) Test data taken with water at 70°F for pumps with 60 hertz motors at 3450 RPM (to convert data to PSI, divide feet of head by 2.31).

Pump performance when pump is new. As pump wears, the performance will decrease.

(\*\*) AC HP required at specified RPM is HP rated to handle up to 100 SSU at full flow, with a maximum specific gravity of 1.1, or up to 200 SSU at 1.0 specific gravity or less.

NOTES: Max. Viscosity = For viscosity up to 400 SSU (at 1.0 specific gravity or less), increase motor HP by one size but not to exceed standard 3 HP motor at 3450 RPM or 65 in.lbs of torque. For fluids with a viscosity greater than 400 SSU, pump speed must be reduced below 3450 RPM.

Max. Casing PSI = 100 Max. RPM = 3450

Max. Specific Gravity = up to 1.1 for standard models (at 100 SSU or less); HP must be increased by one size for specific gravities up to 1.4.

Driver data is subject to change without notice; see label on driver for actual specifications.

Manufacturer reserves the right to change performance without notification.

## Specifications (Pump heads only)

Model Number	SUGGESTED DRIVER (Motor Not Included)				Port Size NPT Female (Inlet and Outlet)	PUMP CONSTRUCTION (Wet End)				Ship Wt. (lbs.)
	HP	NEMA Frame	RPM	Shaft		Housing & Body Adapter	Impeller	Seals*		
Noryl Models										
CHMNA1X	3/4	56J	3450	NA	1½"	Noryl	Noryl	Noryl/Viton**	4	
CHMNA2X	3/4	56J	3450	NA	1½"	Noryl	Noryl	Noryl/Viton**	4	
CHMNA3X	1	56J	3450	NA	1½"	Noryl	Noryl	Noryl/Viton**	4	
CHMNA4X	1½	56J	3450	NA	1½"	Noryl	Noryl	Noryl/Viton**	4	
CHMNA5X	2	56J	3450	NA	1½"	Noryl	Noryl	Noryl/Viton**	4	
CHMNA6X	3	56J	3450	NA	1½"	Noryl	Noryl	Noryl/Viton**	4	
Polypropylene Models										
CHMPB1X	1/3	56J	3450	NA	1½"	PP	PP	Buna-N***	4	
CHMPB2X	1/2	56J	3450	NA	1½"	PP	PP	Buna-N***	4	
CHMPB3X	3/4	56J	3450	NA	1½"	PP	PP	Buna-N***	4	
CHMPB4X	1	56J	3450	NA	1½"	PP	PP	Buna-N***	4	
CHMPB5X	1½	56J	3450	NA	1½"	PP	PP	Buna-N***	4	
CHMPB6X	2	56J	3450	NA	1½"	PP	PP	Buna-N***	4	

SS = Stainless Steel BR = Bronze CI = Cast Iron

(\*) Standard shaft seals have carbon on ceramic faces.

(\*\*) Seals are Noryl encased with Viton elastomer. No metallic components are exposed to fluid.

(\*\*\*) Seal is not encased. 18-8 stainless steel spring and casing are exposed to fluid.

NOTE: Manufacturer reserves the right to change specifications without notification.



# PERFORMANCE & SPECIFICATIONS

## Specifications – Standard Models

Model Number	DRIVER										PUMP CONSTRUCTION (Wet End)				Ship Wt. (lbs.)	
	AC Motor HP	NEMA Frame	Motor Voltage	Full Load Amps	Service Factor Amps ****	Hz	Phase	Thermal Overload Protection	RPM	Shaft	Port Size NPT Female (Inlet and Outlet)	Housing & Body Adapter	Impeller	Seals*		
Noryl Models																
CHMNA12T	1/2	TEFC	56J	115/208-230	7.00/3.80-3.50	8.00/4.00	60	1	Yes	3450	303 SS	1½	Noryl	Noryl	Noryl / Viton **	22
CHMNA123T	1/2	TEFC	56J	208-230/460	1.87-1.70/0.85	1.90/0.95	60	3	No	3450	303 SS	1½	Noryl	Noryl	Noryl / Viton **	23
				190/380	1.90/0.95	****	50	3	No	2830						
CHMNA23T	3/4	TEFC	56J	115/208-230	9.80/5.40-4.90	10.6/5.30	60	1	Yes	3450	303 SS	1½	Noryl	Noryl	Noryl / Viton **	30
CHMNA233T	3/4	TEFC	56J	208-230/460	2.50-2.30/1.15	2.60/1.30	60	3	No	3450	303 SS	1½	Noryl	Noryl	Noryl / Viton **	32
				190/380	2.70/1.35	****	50	3	No	2830						
CHMNA34T	1	TEFC	56J	115/208-230	12.20/6.75-6.10	17.0/8.50	60	1	Yes	3450	303 SS	1½	Noryl	Noryl	Noryl / Viton **	32
CHMNA343T	1	TEFC	56J	208-230/460	3.19-2.88/1.44	3.31/1.65	60	3	No	3510	304 SS	1½	Noryl	Noryl	Noryl / Viton **	33
				190-220/380-415	3.26-2.98/1.63-1.58	****	50	3	No	2885						
CHMNA45T	1½	TEFC	56J	115/208-230	16.60/9.00-8.30	18.94/9.47	60	1	Yes	3450	303 SS	1½	Noryl	Noryl	Noryl / Viton **	35
CHMNA453T	1½	TEFC	56J	208-230/460	4.14-3.74/1.87	4.30/2.15	60	3	No	3520	304 SS	1½	Noryl	Noryl	Noryl / Viton **	37
				190-220/380-415	4.44-3.90/2.22-2.07	****	50	3	No	2895						
CHMNA56T	2	TEFC	56J	115/208-230	19.40/10.70-9.70	22.16/11.08	60	1	Yes	3450	303 SS	1½	Noryl	Noryl	Noryl / Viton **	39
CHMNA563T	2	TEFC	56J	208-230/460	5.46-4.94/2.47	5.68/2.84	60	3	No	3520	304 SS	1½	Noryl	Noryl	Noryl / Viton **	40
				190-220/380-415	5.94-5.23/2.97-2.77	****	50	3	No	2875						
CHMNA67T	3	TEFC	56J	208-230	13.3-12.2	****	60	1	Yes	3450	303 SS	1½	Noryl	Noryl	Noryl / Viton **	53
CHMNA673T	3	TEFC	56J	208-230/460	7.76-7.02/3.51	8.07/4.03	60	3	No	3500	304 SS	1½	Noryl	Noryl	Noryl / Viton **	47
				190-220/380-415	8.50-7.38/4.25-3.91	****	50	3	No	2870						
Polypropylene Models																
CHMPB11	1/3	ODP	56J	115/208-230	7.20/4.00-3.60	8.68/4.78-4.33	60	1	Yes	3450	303 SS	1½	PP	PP	Buna-N ***	21
CHMPB22	1/2	ODP	56J	115/208-230	11.10/6.50-5.55	12.40/6.80-6.20	60	1	Yes	3450	303 SS	1½	PP	PP	Buna-N ***	23
CHMPB223	1/2	ODP	56J	208-230/460	1.85-1.85/0.92	2.53/1.27	60	3	No	3450	303 SS	1½	PP	PP	Buna-N ***	24
				190/380	2.04/1.02	****	50	3	No	2830						
CHMPB33	3/4	ODP	56J	115/208-230	13.00/7.20-6.50	15.30/8.45-7.65	60	1	Yes	3450	303 SS	1½	PP	PP	Buna-N ***	26
CHMPB333	3/4	ODP	56J	208-230/460	2.46-2.39/1.20	3.59/1.80	60	3	No	3450	303 SS	1½	PP	PP	Buna-N ***	27
				190/380	2.88/1.44	****	50	3	No	2830						
CHMPB44	1	ODP	56J	115/208-230	12.40/6.85-6.20	15.7/8.70-7.85	60	1	Yes	3450	303 SS	1½	PP	PP	Buna-N ***	29
CHMPB443	1	ODP	56J	208-230/460	3.17-3.11/1.55	4.07/2.03	60	3	No	3450	303 SS	1½	PP	PP	Buna-N ***	28
				190/380	3.70/1.83	****	50	3	No	2830						
CHMPB55	1½	ODP	56J	115/208-230	17.00/9.35-8.50	21.00/10.40-10.50	60	1	Yes	3450	303 SS	1½	PP	PP	Buna-N ***	29
CHMPB553	1½	ODP	56J	208-230/460	4.50-4.26/2.13	5.55/2.77	60	3	No	3450	303 SS	1½	PP	PP	Buna-N ***	31
				190/380	5.18/2.59	****	50	3	No	2830						
CHMPB66	2	ODP	56J	115/230	18.2/9.1	21.6/10.8	60	1	Yes	3450	303 SS	1½	PP	PP	Buna-N ***	40
CHMPB663	2	ODP	56J	208-230/460	5.80-5.20/2.60	6.20/3.10	60	3	No	3450	303 SS	1½	PP	PP	Buna-N ***	38
				190/380	6.40/3.20	****	50	3	No	2830						

SS = Stainless Steel PP = Polypropylene

(\*) Standard Shaft Seals have carbon on ceramic faces.

(\*\*) Seals are Noryl encased with Viton elastomer. No metallic components are exposed to fluid.

(\*\*\*) Seal is not encased. 18-8 stainless steel spring and casing are exposed to fluid.

(\*\*\*\*) At 208 volts or 50 hertz, the Service Factor Amps are the same as the Full Load Amps.

NOTES: Driver data is subject to change without notice, see label on driver for actual specifications.

All motors include a base (the base may be removable, movable or welded). Motors are not supplied with power cords.

Manufacturer reserves the right to change specifications without notification.

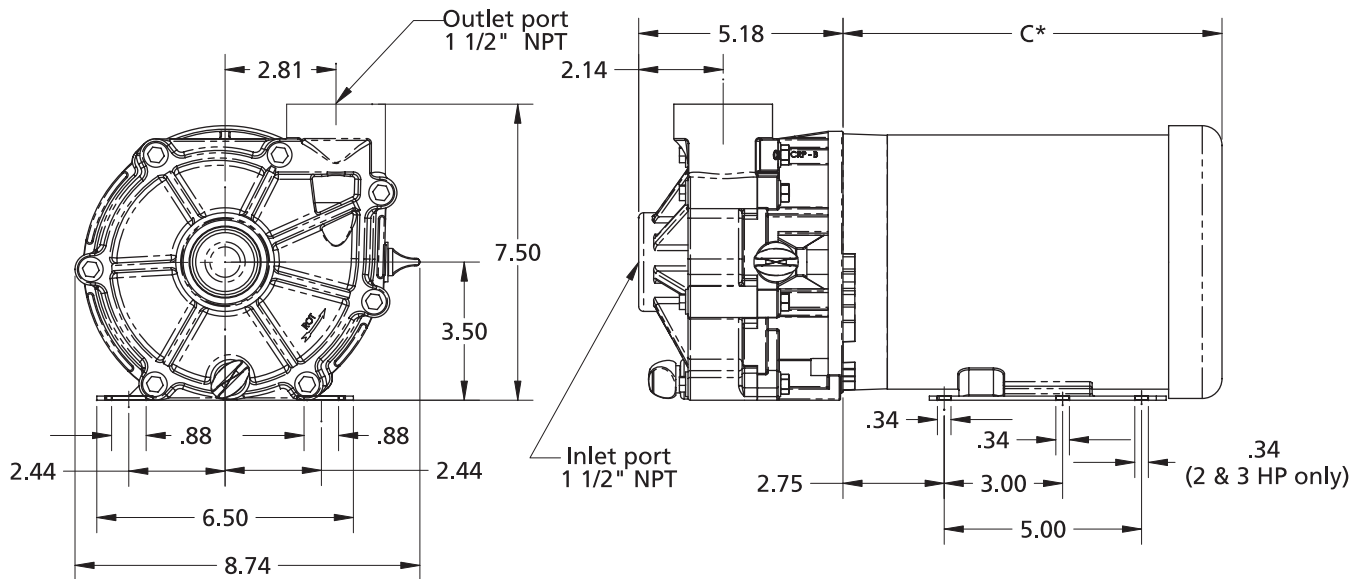
Standard motors listed above are not wash-down or explosion-proof (manufacturer does not stock wash-down or explosion-proof motors).

Thermal overload protection is standard on all single-phase motors (overload protector may have automatic or manual reset); three-phase motors are not provided with thermal overload protection.

Manufacturer does not specify regulatory compliance for UL, UR, CSA or CE; however most models do comply to UL, UR, CSA and CE.

# DIMENSIONS

Dimensions = Inches



NOTE: Dimensions have a tolerance of  $\pm 1/8"$ .

## C\* Dimension

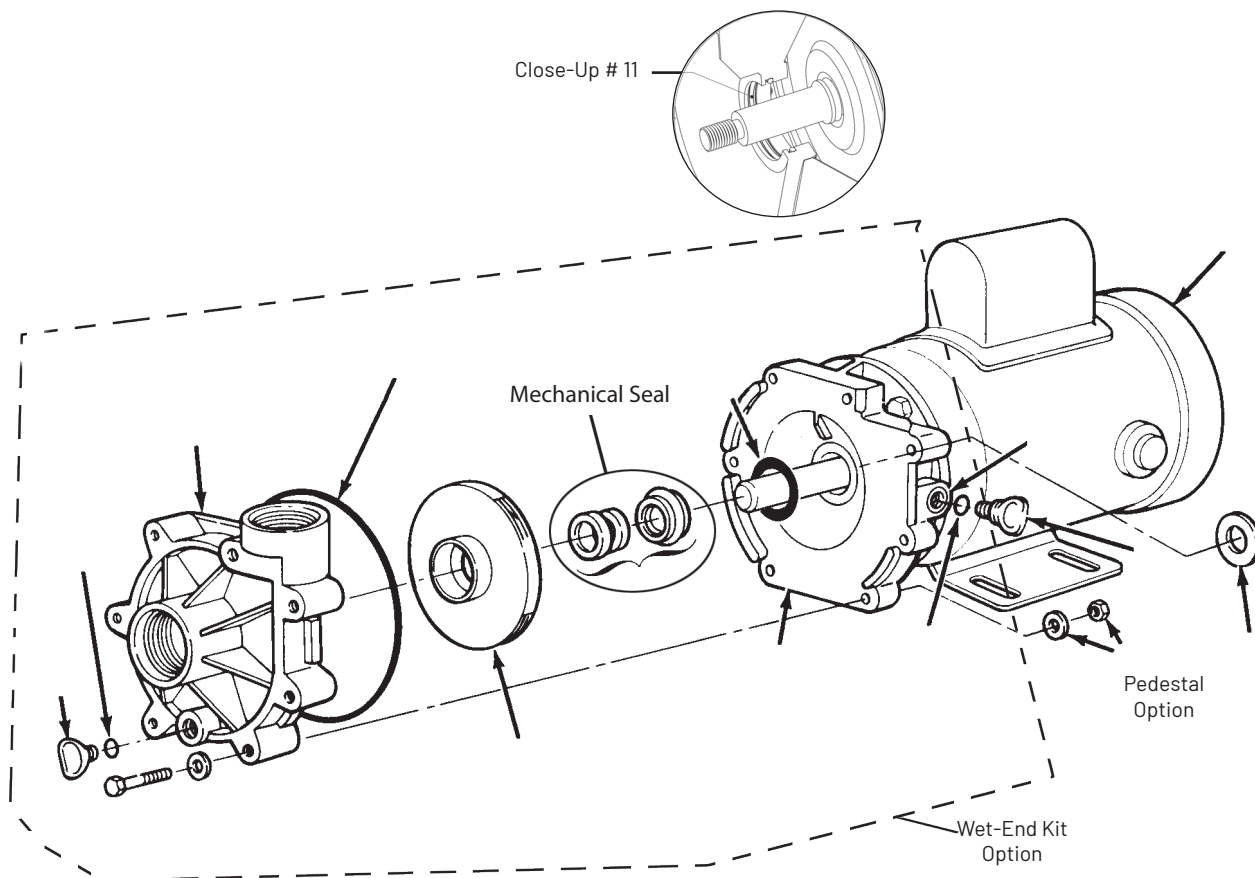
Noryl Units												
	CHMNA12T	CHMNA123T	CHMNA23T	CHMNA233T	CHMNA34T	CHMNA343T	CHMNA45T	CHMNA453T	CHMNA56T	CHMNA563T	CHMNA67T	CHMNA673T
C Dimension	9.25	9.25	10.38	9.75	10.38	10.25	-	11.06	-	11.85	-	13.03
Polypropylene Units												
	CHMPB11	CHMPB22	CHMPB223	CHMPB33	CHMPB333	CHMPB44	CHMPB443	CHMPB55	CHMPB553	CHMPB66	CHMPB663	
C Dimension	8.38	8.62	8.36	9.38	9.36	9.62	9.86	9.87	10.86	9.87	9.38	

# PARTS LIST

To order parts, contact a SHURflo distributor or order direct. Distributors can be found at [www.shurfloindustrial.com](http://www.shurfloindustrial.com).

Please provide the following information when ordering:

- ◆ Model #
- ◆ Serial # (if applicable)
- ◆ Part description and # as shown in Parts List



## Electric Motors Selection (Item 10)

HP	1 Phase ODP P/N	Motor Suffix	3 Phase ODP P/N	Motor Suffix	1 Phase TEFC P/N	Motor Suffix	3 Phase TEFC P/N	Motor Suffix
1/3	14010H	1	NA	13	NA	1T	NA	13T
1/2	14011H	2	24361H	23	24499H	2T	13431H	23T
3/4	14012H	3	14015H	33	13409H	3T	14017H	33T
1	14013H	4	12991H	43	24500H	4T	18741H	43T
1-1/2	14014H	5	14016H	53	13410H	5T	14018H	53T
2	12985H	6	13341H	63	13411H	6T	19495H	63T
3	24364H	7	24365H	73	24366H	7T	23424H	73T

NA = Not Available

NOTE: The standard pump and motor combinations are offered with ODP motors which have larger service factors than the same TEFC motor.

When mating a TEFC motor to a pump head or replacing an ODP motor with a TEFC motor, use one HP rating higher for 1/3, 1/2, 3/4, 1 and 1-1/2 HP motors.

Example: A TEFC motor on a standard model is a COMC11, which uses a 1/3 HP ODP motor.

# PARTS LIST

## Repair Parts List for Noryl Pumps

Ref. No.	Description	Part Number for Pump Head Model:						Qty
		CHMNA1	CHMNA2	CHMNA3	CHMNA4	CHMNA5	CHMNA6	
1	Body Adapter	18775	18775	18775	18775	18775	18775	1
2	Pump Housing	13257	13257	13257	13257	13257	13257	1
3	Drain Plug or Water Flush Plug	13261	13261	13261	13261	13261	13261	2
4	Impeller	24668	23438	23439	13255	13256	13343	1
5	Seal/Seat Assy. (Noryl/Viton/Carbon/Ceramic) † <sup>1</sup>	24455S	24455S	24455S	24455S	24455S	24455S	1
	Seal Assembly (Noryl/Viton/Silicon Carbide) *† <sup>1</sup>	24456S	24456S	24456S	24456S	24456S	24456S	1
	Seal Assembly (SS/Viton/Carbon/Ceramic) *† <sup>2</sup> 13263S	13263S	13263S	13263S	13263S	13263S	1	
	Seal Assembly (SS/Viton/Silicon Carbide) *† <sup>2</sup> 24466S	24466S	24466S	24466S	24466S	24466S	1	
	Seal Assembly (SS/Buna-N/Carbon/Ceramic) *† <sup>2</sup>	24443S	24443S	24443S	24443S	24443S	24443S	1
	Seal Assembly (SS/Neoprene/Carbon/Ni-Resist) * <sup>3</sup>	17567S	17567S	17567S	17567S	17567S	17567S	1
6	O-ring gasket (Viton)	13259	13259	13259	13259	13259	13259	1
	O-ring gasket (Buna-N)*	13264	13264	13264	13264	13264	13264	1
7	Plug O-ring (Viton)	13312	13312	13312	13312	13312	13312	2
	Plug O-ring (Buna-N)*	13313	13313	13313	13313	13313	13313	2
8	Fastener kit (18-8 Stainless Steel) (includes screws, washers & nuts)	13437	13437	13437	13437	13437	13437	1
9	Slinger	14990	14990	14990	14990	14990	14990	1
10	Motor (See motor chart-Item 10)	-	-	-	-	-	-	1
11	Seal O-ring (Viton)	18807	18807	18807	18807	18807	18807	1
	Seal O-ring (Buna-N)*	18818	18818	18818	18818	18818	18818	1

(\*) Optional

(†) Seals also contain 316 stainless steel components and have Viton bellows.

(‡) Seals also contain 316 stainless steel components and have Buna-N bellows.

(1) Seals are encased with Noryl. No metallic components are exposed to fluid.

(2) Seals are not encased. Stainless steel case and spring are exposed to fluid.

(3) Seals are encased with Polypropylene. No metallic components are exposed to fluid.

## Replacement Pump Heads-Noryl

Description	Pump Head No.
1/2 HP Noryl Pump Head	CHMNA1X
3/4 HP Noryl Pump Head	CHMNA2X
1 HP Noryl Pump Head	CHMNA3X
1-1/2 HP Noryl Pump Head	CHMNA4X
2 HP Noryl Pump Head	CHMNA5X
3 HP Noryl Pump Head	CHMNA6X

NOTES: All Replacement Pump Heads come with standard seal listed as Ref. No. 5 above.

An optional 56J Pedestal Base is also available as part number 24479.

See Figure 5 for pedestal dimensional data.

# PARTS LIST

## Repair Parts List for Polypropylene Pumps

Ref. No.	Description	Part Number for Pump Head Model:						Qty
		CHMPB1	CHMPB2	CHMPB3	CHMPB4	CHMPB5	CHMPB6	
1	Body Adapter	18739	18739	18739	18739	18739	18739	1
2	Pump Housing	13474	13474	13474	13474	13474	13474	1
3	Drain Plug or Water Flush Plug	18355	18355	18355	18355	18355	18355	2
4	Impeller	24669	19539	19540	18351	18352	18353	1
5	Seal/Seat Assy. (Buna-N/Carbon/Ceramic) † <sup>2</sup> 24443S	24443S	24443S	24443S	24443S	24443S	1	
	Seal Assembly (PP/Viton/Silicon Carbide) * † <sup>3</sup> 15047S	15047S	15047S	15047S	15047S	15047S	1	
	Seal Assembly (PP/Viton/Carbon/Ceramic) * † <sup>1</sup> 14528S	14528S	14528S	14528S	14528S	14528S	1	
	Seal Assembly (SS/Viton/Carbon/Ceramic) * † <sup>1</sup> 13263S	13263S	13263S	13263S	13263S	13263S	1	
	Seal Assembly (SS/Viton/Silicon Carbide) * † <sup>2</sup> 24466S	24466S	24466S	24466S	24466S	24466S	1	
	Seal Assembly (SS/Neoprene/Carbon/Ni-Resist) * <sup>3</sup>	17567S	17567S	17567S	17567S	17567S	17567S	1
6	O-ring gasket (Buna-N)	13264	13264	13264	13264	13264	13264	1
	O-ring gasket (Viton)*	13259	13259	13259	13259	13259	13259	1
7	Plug O-ring (Buna-N)	13313	13313	13313	13313	13313	13313	2
	Plug O-ring (Viton)*	13312	13312	13312	13312	13312	13312	2
8	Fastener kit (18-8 Stainless Steel) (includes screws, washers & nuts)	13437	13437	13437	13437	13437	13437	1
9	Slinger	14990	14990	14990	14990	14990	14990	1
10	Motor (See motor chart-Item 10)	-	-	-	-	-	-	1
11	Seal O-ring (Buna-N)	18818	18818	18818	18818	18818	18818	1
	Seal O-ring (Viton)*	18807	18807	18807	18807	18807	18807	1

(\*) Optional

(†) Seals also contain 316 stainless steel components and have Viton bellows.

(‡) Seals also contain 316 stainless steel components and have Buna-N bellows.

(1) Seals are encased with Noryl. No metallic components are exposed to fluid.

(2) Seals are not encased. Stainless steel case and spring are exposed to fluid.

(3) Seals are encased with Polypropylene. No metallic components are exposed to fluid.

# PARTS LIST

## Replacement Pump Heads-Polypropylene

Description	Pump Head No.
1/3 HP Polypropylene Pump Head	CHMPB1X
1/2 HP Polypropylene Pump Head	CHMPB2X
3/4 HP Polypropylene Pump Head	CHMPB3X
1 HP Polypropylene Pump Head	CHMPB4X
1-1/2 HP Polypropylene Pump Head	CHMPB5X
2 & 3 HP Polypropylene Pump Head	CHMPB6X

NOTES: All Replacement Pump Heads come with standard seal listed as Ref. No. 5 above.  
 An optional 56J Pedestal Base is also available as part number 24479.  
 See Figure 5 for pedestal dimensional data.

(Optional) Pedestal Pump Mount Part Number 24479  
 (Replaces 56J frame motor)  
 (When long coupling or pulley drive is required)

NOTE: Dimensions have a tolerance of  $\pm 1/8"$ .  
 ( $\emptyset$ ) Diameter.

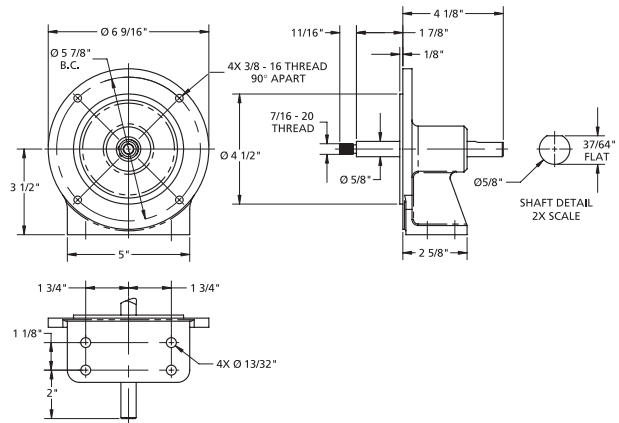
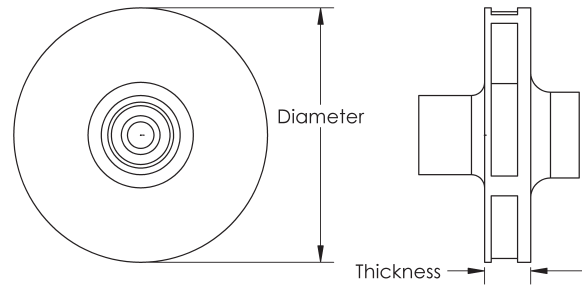


Figure 5

# PARTS LIST

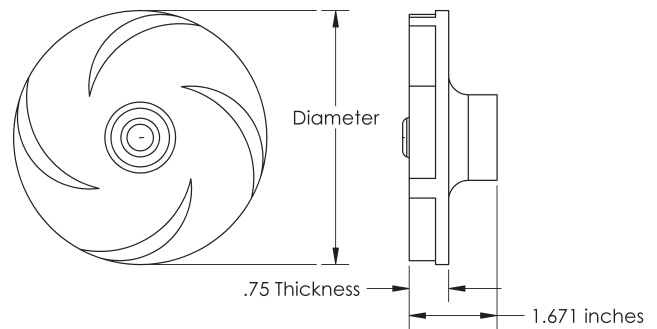
## Closed Impeller Identification Chart



Size (ODP HP)	Flow to: GPM@10ft	Max. Head (ft)	Noryl Part#	Polypropylene Part#	Thickness (inches)	Diameter (inches)
1(1/3)	33	68	24668	24669	0.43	4.44
2(1/2)	45	72	23438	19539	0.43	4.82
3(3/4)	65	79	23439	19540	0.53	4.82
4(1)	85	89	13255	18351	0.73	4.82
5(1-1/2)	96	91	13256	18352	0.61	4.82
6(2)	123	95	13343	18353	0.75	4.82

NOTES: All Noryl impellers are black in color. All Polypropylene impellers are white.

## Open Impeller Identification Chart (Optional)



Size (ODP HP)	Flow to: GPM@10ft	Max. Head (ft)	Noryl Part#	Polypropylene Part#	Thickness (inches)	Diameter (inches)
1(1/3)	-	-	N/A	N/A	0.75	N/A
2(1/2)	85	42	N/A	13476	0.75	3.58
3(3/4)	92	45	N/A	13477	0.75	3.62
4(1)	107	62	N/A	13478	0.75	4.16
5(1-1/2)	115	71	N/A	13799	0.75	4.44
6(2)	123	80	N/A	13800	0.75	4.83

NOTES: All Noryl impellers are black in color. All Polypropylene impellers are white.

## TROUBLESHOOTING

Symptom	Possible Cause(s)	Corrective Action
Pump will not prime or retain prime after operating	<ol style="list-style-type: none"> <li>1. Air Leak in suction line</li> <li>2. Clogged strainer</li> <li>3. Leaky foot valve</li> </ol>	<ol style="list-style-type: none"> <li>1. Repair or replace suction line</li> <li>2. Clean or replace strainer</li> <li>3. Clean, repair or replace foot valve</li> </ol>
Flow rate is low	<ol style="list-style-type: none"> <li>1. Incorrect speed</li> <li>2. Piping is fouled or damaged</li> <li>3. Clogged impeller or worn impeller</li> <li>4. Discharge line restricted or undersized</li> <li>5. High discharge pressure</li> </ol>	<ol style="list-style-type: none"> <li>1. Check drive</li> <li>2. Clean or replace</li> <li>3. Clean or replace</li> <li>4. Flush out piping or replace</li> <li>5. Check and reduce</li> </ol>
Pump runs but there is no fluid	<ol style="list-style-type: none"> <li>1. Faulty suction piping</li> <li>2. Pump is located too far from the fluid source</li> <li>3. Gate valve is closed</li> <li>4. Clogged strainer</li> <li>5. Fouled foot valve</li> <li>6. Discharge height is too great</li> <li>7. Suction lift is too great</li> <li>8. Reverse rotation</li> </ol>	<ol style="list-style-type: none"> <li>1. Replace</li> <li>2. Relocate</li> <li>3. Open</li> <li>4. Clean or replace</li> <li>5. Clean or replace</li> <li>6. Lower the height</li> <li>7. Lower the pump</li> <li>8. Reverse rotation</li> </ol>
Liquid drips from point where shaft enters the pump casing, when pump is full of liquid	<ol style="list-style-type: none"> <li>1. Damaged mechanical seal</li> <li>2. Liquid not compatible with seal</li> </ol>	<ol style="list-style-type: none"> <li>1. Replace mechanical seal</li> <li>2. Check compatibility; use components that are compatible</li> </ol>
The pump starts and stops pumping	<ol style="list-style-type: none"> <li>1. Fouled impeller</li> <li>2. Faulty mechanical seal</li> <li>3. Leak in the suction line</li> <li>4. Leak in the foot valve</li> <li>5. Impeller spun off and jammed against housing</li> </ol>	<ol style="list-style-type: none"> <li>1. Clean</li> <li>2. Replace</li> <li>3. Repair</li> <li>4. Repair or replace</li> <li>5. Check motor rotation; reverse if necessary</li> </ol>
Excessive noise while pump is in operation	<ol style="list-style-type: none"> <li>1. Pump not secured to firm foundation</li> <li>2. Piping not supported to relieve any strain on the pump assembly</li> <li>3. Restricted suction line</li> <li>4. Cavitation</li> </ol>	<ol style="list-style-type: none"> <li>1. Secure properly</li> <li>2. Make necessary adjustments</li> <li>3. Clean or correct</li> <li>4. <ol style="list-style-type: none"> <li>a. Reduce speed</li> <li>b. Increase inlet size</li> <li>c. Use thinner material</li> </ol> </li> </ol>
Pump runs but poor performance	<ol style="list-style-type: none"> <li>1. Check pump rotation to see if it is CCW as viewed from motor face. On three-phase motors, rotation must be checked prior to running pump under load.</li> </ol>	<ol style="list-style-type: none"> <li>1. On three-phase motors, switch any two motor wire leads to reverse rotation.</li> </ol>



---

This page intentionally left blank.

---

This page intentionally left blank.

# WARRANTY

## Limited Warranty

SHURflo warrants to the original purchaser of its products (the "Purchaser") that such products will be free from defects in material and workmanship under normal use for the period of one (1) year, and accessories will be free from defects in material and workmanship under normal use for the period of ninety (90) days. "Normal use" does not include use in excess of recommended maximum speeds, pressures, vacuums and temperatures, or use requiring handling of fluids not compatible with component materials. This warranty does not cover freight damage, freezing damage, normal wear and tear, or damage caused by misapplication, fault, negligence, alterations, or repair that affects the performance or reliability of the product.

**THIS WARRANTY IS EXCLUSIVE. SHURflo MAKES NO OTHER WARRANTY, EXPRESS OR IMPLIED, INCLUDING BUT NOT LIMITED TO ANY WARRANTY OF MERCHANTABILITY OR FITNESS FOR A PARTICULAR PURPOSE.**

SHURflo's obligation under this warranty is, at SHURflo's option, to either repair or replace the product upon return of the entire product to the SHURflo factory in accordance with the return procedures set forth below. **THIS IS THE EXCLUSIVE REMEDY FOR ANY BREACH OF WARRANTY.**

**IN NO EVENT SHALL SHURflo BE LIABLE FOR ANY INCIDENTAL OR CONSEQUENTIAL DAMAGES OF ANY KIND, WHETHER FOR BREACH OF ANY WARRANTY, FOR NEGLIGENCE, ON THE BASIS OF STRICT LIABILITY, OR OTHERWISE.**

**Only authorized distributors can return products for Warranty. Contact your distributor or visit [www.shurfloindustrial.com](http://www.shurfloindustrial.com) to find a distributor for product support.**

**Distributors can obtain an RMA # and contact person's name by contacting SHURflo's customer service at 800-854-3218 (Ext. 6788 or Ext. 6651).**

### Return Procedures for Distributors:

All pumps or products must be flushed of any chemical (ref. OSHA Section 0910.1200 (d)(e)(f)(g)(h) and hazardous chemicals must be labeled before being shipped\* to SHURflo for service or warranty consideration. SHURflo reserves the right to request a Material Safety Data sheet from the Purchaser for any pump or product SHURflo deems necessary. SHURflo reserves the right to "disposition as scrap" pumps or products returned which contain unknown substances, or to charge for any and all costs incurred for chemical testing and proper disposal of components containing unknown substances. SHURflo requests this in order to protect the environment and personnel from the hazards of handling unknown substances.

Be prepared to give SHURflo full details of the problem, including the following information:

1. Model number, purchase date and from whom you purchased your pump.
2. A brief description of the pump problem, including the following:
  - Liquid pumped. State the pH and any non-soluble
  - Temperature of the liquid and ambient environment.
  - Suction lift or vacuum (measured at the pump).
  - Discharge pressure.
  - Drive type (gas engine/electric motor; direct/belt drive; materials, and give the generic or trade name. tractor PTO) and rpm of pump.
  - Size, type, and mesh of the suction strainer.
  - Viscosity (of oil, or other than water weight liquid).
  - Elevation from the pump to the discharge point.
  - Size and material of suction and discharge line.

SHURflo may request additional information, and may require a sketch to illustrate the problem. Distributors should contact the factory to receive a return material authorization before sending the product. All pumps returned for warranty work should be sent shipping charges prepaid to:

[RMA# and Contact Person]  
SHURflo  
375 Fifth Avenue NW  
New Brighton, Minnesota 55112

\*Carriers, including U.S.P.S., airlines, UPS, ground freight, etc., require specific identification of any hazardous materials being shipped. Failure to do so may result in a substantial fine and/or prison term. Check with your shipping company for specific instructions.



5900 KATELLA AVE | CYPRESS, CA 90630 | PH: (800) 854-3218 | ORDERS FAX: (562) 795-7554 | [PENTAIR.COM/SHURFLO](https://www.pentair.com/shurflo)

For a detailed list of where Pentair trademarks are registered, please visit [www.pentair.com/en/registrations.html](https://www.pentair.com/en/registrations.html). Pentair trademarks and logos are owned by Pentair plc or its affiliates. Third party registered and unregistered trademarks and logos are the property of their respective owners. Because we are continuously improving our products and services, Pentair reserves the right to change specifications without prior notice. Pentair is an equal opportunity employer.

L-4072 (04-05-20) ©2020 Pentair. All Rights Reserved.