

Please read and save this Repair Parts Manual. Read this manual and the General Operating Instructions carefully before attempting to assemble, install, operate or maintain the product described. Protect yourself and others by observing all safety information. The Safety Instructions are contained in the General Operating Instructions. Failure to comply with the safety instructions accompanying this product could result in personal injury and/or property damage! Retain instructions for future reference.

SHURflo 316 Stainless Steel Rotary Close-Coupled External Gear Pumps

Refer to form L-4082 for General Operating and Safety Instructions and Applicable Warranty.

Description

SHURflo self-priming, positive displacement, external rotary gear pumps operate bi-directionally (reversible) and provide a nearly pulseless flow for a wide range of industrial, marine, agricultural, and commercial chemical-duty applications. Mounted directly to NEMA frame AC Totally-Enclosed Fan-Cooled (TEFC) motors using an easy-installation package, or as pump heads only for custom installations. Single-phase motors are thermally overload protected; 3-phase motors are not. Ryton PPS (Polyphenylene Sulfide) spur gears provide quiet operation and chemical compatibility with no metal-to-metal contact. Pumps can operate in a temperature range of 32° to 280° F.

Quality features include a keyed 316 stainless steel shaft supported by a ball bearing and carbon graphite bushings. Wet-end parts are constructed of 316 stainless steel, Ryton PPS, graphite, graphoil, carbon, ceramic, and Viton or Teflon®.

Uses: For use with non-particulate and non-abrasive fluids compatible with pump wet-end construction component materials.

- Capacities up to 24.8 GPM.
- Maximum pressure to 125 PSI and working casing pressure to 200 PSI.
- Max. RPM: 1725.
- Suction lift to 19.5 ft.
- Temperature ranges from 32° to 280° F.
- Large female NPT ports allow use with viscous fluids.
- Pumps are close-coupled with electric motors to handle up to 500 SSU at 1725 RPM or run at reduced speeds to handle a wide range of pump fluid viscosities and specific gravity up to 100,000 SSU. (Maximum torque loads are found in the performance chart.)
- Viton or Teflon® mechanical seals (standard) with carbon on ceramic faces with engineered flush chamber for internal or external flush to handle viscosities beyond 2000 SSU.
- Pumps can operate bi-directionally (reversible).

REPAIR SEALS AND OPTIONS – Standard seals are Viton or Teflon® (Buna-N is optional) with carbon on ceramic faces. Seals can be located in the repair parts list pages in the owner's manual. When switching between standard and optional mechanical seals, be sure to order the matching o-rings in the same material. These can be found in the repair parts list pages of this manual.

Optional Close-Coupled Gear Speed Reducers are available that mount directly between pump and motor to reduce pump speed for high viscosity or high specific gravity applications (See Appendix 2).

NOTE: This series of gear pumps is also available as pedestal models for custom applications.



WARNING: Do not use to pump flammable or explosive fluids such as gasoline, fuel oil, kerosene, etc. Do not use in flammable and/or explosive atmospheres. When pumping hazardous or dangerous materials, use only in a room or area designated for that purpose. For your protection, always wear proper clothing, eye protection, etc. in case of any malfunction. For proper handling techniques and cautions, contact your chemical supplier, insurance company and local agencies (fire dept., etc.). Failure to comply with this warning could result in personal injury and/or property damage.

SHURflo 316 Stainless Steel Rotary Close-Coupled External Gear Pumps

Model Ordering Codes and Options

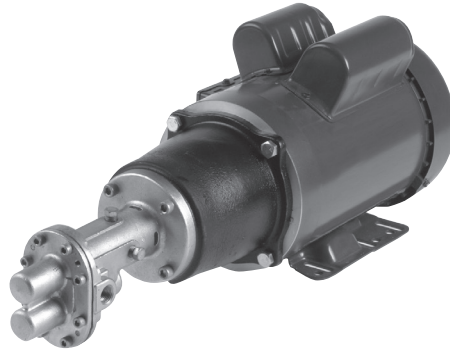

Example Model: GMSV4A (will require 1½ HP ODP motor with >1.15 Service Factor*)
(Model pictured above is pump head without motor.)

1st	2nd	3rd	4th	5th	6th	7th
Mounting	Material	Seal (Mech)	Gear** Size: Ports	Motor-Mounted Only		
				Brackets	HP	AC Type
GM: Gear Motor Mount	S: 316 Stainless Steel	V: Viton T: Teflon	2: 3/8" 4: 1/2" 6: 1"	A: 56C B: 143/145TC C: 182/184TC	1: 1/3 2: 1/2 3: 3/4 4: 1 5: 1½ 6: 2 7: 3	"Blank": no code single phase ODP motor 3: 3 phase ODP motor T: 1 phase TEFC 3T: 3 phase TEFC

NOTE: Not all order code combinations (configurations) are standard models available from the manufacturer. Custom model configurations may require ordering standard components and/or optional parts that will need to be assembled by the customer.

Manufacturer reserves the right to change model order codes, standard models, specifications, and performance without notification.

(*) ODP motors have > 1.15 service factors. Due to service factor, it is recommended TEFC motors are oversized by one HP increment.

(**) Gears are made of Ryton PPS (Polyphenylene Sulfide).

Maximum motor speed is 1725 RPM.

**Viton Models GMSV2A, GMSV4A, GMSV6C, GMSV2A3T, GMSV2A33T,
GMSV4A5T, GMSV4A53T, GMSV6C7T and GMSV6C73T
Teflon® Models GMST2A, GMST4A, GMST6C, GMST2A3T, GMST2A33T,
GMST4A5T, GMST4A53T, GMST6C7T and GMST6C73T**

Performance (with Oil)

Viton Pump Models	Teflon Pump Models	*Port Size	Max. Input Torque in.-lbs.	Pump RPM	Suction** Lift (ft)	GPM Pumping 10 Wt. Oil at 70° F (500 SSU)											
						Free Flow		25 PSI		50 PSI		75 PSI		100 PSI		125 PSI	
						GPM	HP	GPM	HP	GPM	HP	GPM	HP	GPM	HP	GPM	HP
GMSV2A	GMST2A	3/8"	45	900	1.5	2.5	1/4	2.5	1/4	2.4	1/4	2.3	1/4	2.1	1/4	1.8	1/3
GMSV2A	GMST2A	3/8"	45	1200	2.2	3.3	1/4	3.3	1/4	3.2	1/4	3.1	1/3	2.9	1/3	2.6	1/2
GMSV2A	GMST2A	3/8"	45	1725	3.5	4.8	1/4	4.8	1/3	4.7	1/2	4.6	1/2	4.4	3/4	4.1	3/4
GMSV2A3T	GMST2A3T	3/8"	45	1725	3.5	4.8	1/4	4.8	1/3	4.7	1/2	4.6	1/2	4.4	3/4	4.1	3/4
GMSV2A33T	GMST2A33T	3/8"	45	1725	3.5	4.8	1/4	4.8	1/3	4.7	1/2	4.6	1/2	4.4	3/4	4.1	3/4
GMSV4A	GMST4A	1/2"	90	900	5.1	5.6	1/3	5.5	1/3	5.4	1/2	5.3	3/4	5.0	1	4.5	1
GMSV4A	GMST4A	1/2"	90	1200	6.7	7.5	1/3	7.4	1/2	7.3	3/4	7.2	1	6.9	1	6.4	1 1/2
GMSV4A	GMST4A	1/2"	90	1725	12.3	10.8	1/2	10.7	3/4	10.6	3/4	10.5	1	10.2	1 1/2	9.7	1 1/2
GMSV4A5T	GMST4A5T	1/2"	90	1725	12.3	10.8	1/2	10.7	3/4	10.6	3/4	10.5	1	10.2	1 1/2	9.7	1 1/2
GMSV4A53T	GMST4A53T	1/2"	90	1725	12.3	10.8	1/2	10.7	3/4	10.6	3/4	10.5	1	10.2	1 1/2	9.7	1 1/2
GMSV6C	GMST6C	1"	160	900	8.1	12.6	1/2	12.5	3/4	12.3	1	12.1	1	11.7	1 1/2	11.1	1 1/2
GMSV6C	GMST6C	1"	160	1200	11.7	16.7	3/4	16.6	1	16.4	1 1/2	16.2	1 1/2	15.8	2	15.2	2
GMSV6C	GMST6C	1"	160	1725	19.5	24.8	3/4	24.7	1	24.5	1 1/2	24.3	2	23.9	3	23.3	3
GMSV6C7T	GMST6C7T	1"	160	1725	19.5	24.8	3/4	24.7	1	24.5	1 1/2	24.3	2	23.9	3	23.3	3
GMSV6C73T	GMST6C73T	1"	160	1725	19.5	24.8	3/4	24.7	1	24.5	1 1/2	24.3	2	23.9	3	23.3	3

Test data taken on SAE 10 wt. oil at 70° F. (500 SSU).
Performance in water will decrease by about 10%, and HP required will also be reduced by 10% (see the chart below).
Pump performance when pump is new. As pump wears, the performance will decrease.
(* Female NPT inlet and outlet (in inches).
(**) Suction lift requires wetted gears and primed seal chamber.

NOTES: Max. PSI = 125, Max. Viscosity = 500 SSU at 1725 RPM with standard spur gears, Max. RPM = 1725
Max. Specific Gravity = 1.1 at 125 PSI, up to 1.6 at lower PSI & viscosity. Max. Input Torque = See chart above.
Reverse Rotation = Pumps can be run in reverse rotation.
The pump relationship between volume (GPM), pressure (PSI), speed (RPM) and horsepower is shown on performance chart in Shurflo Motor Manual form L-4082. When pumping a more viscous liquid, a slower speed, a larger pipe size pump, and possibly a larger motor should be selected.
Manufacturer reserves the right to change performance without notification.

Performance (with Water)

Viton Pump Models	Teflon Pump Models	*Port Size	Max. Input Torque in.-lbs.	Pump RPM	Suction** Lift (ft)	GPM Pumping Water at 90° F (31 SSU)											
						Free Flow		25 PSI		50 PSI		75 PSI		100 PSI		125 PSI	
						GPM	HP	GPM	HP	GPM	HP	GPM	HP	GPM	HP	GPM	HP
GMSV2A	GMST2A	3/8"	45	900	1.2	2.4	1/4	2.3	1/4	2.1	1/4	1.8	1/4	1.5	1/3	1.1	1/3
GMSV2A	GMST2A	3/8"	45	1200	1.8	3.2	1/4	3.1	1/4	2.9	1/3	2.6	1/3	2.3	1/2	1.9	1/2
GMSV2A	GMST2A	3/8"	45	1725	3.0	4.6	1/3	4.5	1/2	4.2	1/2	4.0	1/2	3.7	3/4	3.3	3/4
GMSV2A3T	GMST2A3T	3/8"	45	1725	3.0	4.6	1/3	4.5	1/2	4.2	1/2	4.0	1/2	3.7	3/4	3.3	3/4
GMSV2A33T	GMST2A33T	3/8"	45	1725	3.0	4.6	1/3	4.5	1/2	4.2	1/2	4.0	1/2	3.7	3/4	3.3	3/4
GMSV4A	GMST4A	1/2"	90	900	4.5	5.5	1/4	5.1	1/4	4.5	1/3	4.1	1/3	3.7	1/2	3.1	1/2
GMSV4A	GMST4A	1/2"	90	1200	6.0	7.3	1/3	7.0	1/3	6.3	1/2	5.9	1/2	5.5	3/4	4.9	3/4
GMSV4A	GMST4A	1/2"	90	1725	11.0	10.5	1/2	10.2	1/2	9.5	3/4	9.1	3/4	8.7	1	8.1	1
GMSV4A5T	GMST4A5T	1/2"	90	1725	11.0	10.5	1/2	10.2	1/2	9.5	3/4	9.1	3/4	8.7	1	8.1	1
GMSV4A53T	GMST4A53T	1/2"	90	1725	11.0	10.5	1/2	10.2	1/2	9.5	3/4	9.1	3/4	8.7	1	8.1	1
GMSV6C	GMST6C	1"	160	900	7.0	12.6	1/2	12.0	3/4	10.9	3/4	10.1	1	9.1	1 1/2	8.1	2
GMSV6C	GMST6C	1"	160	1200	10.0	16.7	3/4	16.1	3/4	15.0	1	14.2	1 1/2	13.2	2	12.2	2
GMSV6C	GMST6C	1"	160	1725	17.0	24.0	1	23.4	1	22.3	1 1/2	21.5	2	20.5	3	19.5	3
GMSV6C7T	GMST6C7T	1"	160	1725	17.0	24.0	1	23.4	1	22.3	1 1/2	21.5	2	20.5	3	19.5	3
GMSV6C73T	GMST6C73T	1"	160	1725	17.0	24.0	1	23.4	1	22.3	1 1/2	21.5	2	20.5	3	19.5	3

Test data taken with water at 90° F. (31 SSU).
Pump performance when pump is new. As pump wears, the performance will decrease.
(* Female NPT inlet and outlet (in inches). (** Suction lift requires wetted gears and primed seal chamber).
NOTES: Max. PSI = 125, Max. Viscosity = 500 SSU at 1725 RPM with standard spur gears, Max. RPM = 1725
Max. Specific Gravity = 1.1 at 125 PSI, up to 1.6 at lower PSI & viscosity. Max. Input Torque = See chart above.
Reverse Rotation = Pumps can be run in reverse rotation.
The pump relationship between volume (GPM), pressure (PSI), speed (RPM) and horsepower is shown on performance chart in Shurflo Motor Manual form L-4082. When pumping a more viscous liquid, a slower speed, a larger pipe size pump, and possibly a larger motor should be selected.
Manufacturer reserves the right to change performance without notification.

SHURflo 316 Stainless Steel Rotary Close-Coupled External Gear Pumps

Specifications for Pump Heads Only (Motors not included)

Model	NEMA Motor Frame Required	Max. RPM	Pump Shaft Size	Required Motor Shaft	Motor Adapter	PUMP CONSTRUCTION (Wet End)						Shipping Weight (lbs.)
						Port*	Body & Cover Castings	Gear Material	Shaft, Keys & Clip	Gasket Material	O-Rings & Seals**	
Viton Models												
GMSV2A	56C	1725	1/2 Keyed	5/8 Keyed	CI	3/8	316 SS	Ryton PPS	316 SS	Graphoil	Viton	8.9
GMSV4A	56C	1725	5/8 Keyed	5/8 Keyed	CI	1/2	316 SS	Ryton PPS	316 SS	Graphoil	Viton	17.5
GMSV6C	182/184TC	1725	20mm Keyed	1 1/8 Keyed	CI	1	316 SS	Ryton PPS	316 SS	Graphoil	Viton	23.1
Teflon Models												
GMST2A	56C	1725	1/2 Keyed	5/8 Keyed	CI	3/8	316 SS	Ryton PPS	316 SS	Graphoil	Teflon®	8.9
GMST4A	56C	1725	5/8 Keyed	5/8 Keyed	CI	1/2	316 SS	Ryton PPS	316 SS	Graphoil	Teflon®	17.5
GMST6C	182/184TC	1725	20mm Keyed	1 1/8 Keyed	CI	1	316 SS	Ryton PPS	316 SS	Graphoil	Teflon®	23.1

SS = Stainless Steel CI = Cast Iron CG = Carbon Graphite Ryton = PPS (Polyphenylene Sulfide)

(*) Female NPT inlet and outlet (in inches).

(**) Standard Shaft Seals have carbon on ceramic faces and 316 SS components.

NOTE: Driver data is subject to change without notice; see label on driver for specifications and wiring information.
Manufacturer reserves the right to change specifications without notification.

**Viton Models GMSV2A, GMSV4A, GMSV6C, GMSV2A3T, GMSV2A33T,
GMSV4A5T, GMSV4A53T, GMSV6C7T and GMSV6C73T
Teflon® Models GMST2A, GMST4A, GMST6C, GMST2A3T, GMST2A33T,
GMST4A5T, GMST4A53T, GMST6C7T and GMST6C73T**

Specifications for Standard Motor-Mounted Models

Model	AC Motor		NEMA Frame	Motor Voltage*	Amps	PH**	Motor RPM	Pump Shaft Size	Motor Shaft	Motor Adapter	PUMP CONSTRUCTION (Wet End)					Ship Wt. (lbs.)	
	HP	Motor Type									Body & Cover Casting	Gear Material	Shaft, Keys & Clips	Gasket Material	O-Rings & Seals ****		
Viton Models																	
GMSV2A3T	3/4	TEFC	56C	115/230	11.2/5.6	1	1725	1/2 Keyed	5/8 Keyed	CI	3/8	316 SS	Ryton	316 SS	Graphoil	Viton	36.9
GMSV2A33T	3/4	TEFC	56C	230/460	2.6/1.3	3	1725	1/2 Keyed	5/8 Keyed	CI	3/8	316 SS	Ryton	316 SS	Graphoil	Viton	35.9
GMSV4A5T	1½	TEFC	56C	115/230	18.4/9.2	1	1725	5/8 Keyed	5/8 Keyed	CI	1/2	316 SS	Ryton	316 SS	Graphoil	Viton	60.5
GMSV4A53T	1½	TEFC	56C	230/460 190/380	4.8/2.4 5/2.5	3	1750 1450	5/8 Keyed	5/8 Keyed	CI	1/2	316 SS	Ryton	1144 Steel	Graphoil	Viton	53.5
GMSV6C7T	3	TEFC	182/184TC	230	14.7	1	1725	20mm Keyed	1½ Keyed	CI	1	316 SS	Ryton	316 SS	Graphoil	Viton	120.1
GMSV6C73T	3	TEFC	182/184TC	230/460	8.2/4.1	3	1725	20mm Keyed	1½ Keyed	CI	1	316 SS	Ryton	316 SS	Graphoil	Viton	88.1
Teflon Models																	
GMST2A3T	3/4	TEFC	56C	115/230	11.2/5.6	1	1725	1/2 Keyed	5/8 Keyed	CI	3/8	316 SS	Ryton	316 SS	Graphoil	Teflon	36.9
GMST2A33T	3/4	TEFC	56C	230/460	2.6/1.3	3	1725	1/2 Keyed	5/8 Keyed	CI	3/8	316 SS	Ryton	316 SS	Graphoil	Teflon	35.9
GMST4A5T	1½	TEFC	56C	115/230	18.4/9.2	1	1725	5/8 Keyed	5/8 Keyed	CI	1/2	316 SS	Ryton	316 SS	Graphoil	Teflon	60.5
GMST4A53T	1½	TEFC	56C	230/460 190/380	4.8/2.4 5/2.5	3	1750 1450	5/8 Keyed	5/8 Keyed	CI	1/2	316 SS	Ryton	1144 Steel	Graphoil	Teflon	53.5
GMST6C7T	3	TEFC	182/184TC	230	14.7	1	1725	20mm Keyed	1½ Keyed	CI	1	316 SS	Ryton	316 SS	Graphoil	Teflon	120.1
GMST6C73T	3	TEFC	182/184TC	230/460	8.2/4.1	3	1725	20mm Keyed	1½ Keyed	CI	1	316 SS	Ryton	316 SS	Graphoil	Teflon	88.1

SS = Stainless Steel CI = Cast Iron CG = Carbon Graphite Ryton = PPS (Polyphenylene Sulfide) TEFC = Totally-Enclosed Fan-Cooled Motor

(*) Motors are rated at 60 hertz only.

(**) Single-phase motors are thermally overload protected (reset may be automatic or manual); 3-phase motors are not thermally protected.

(***) Female NPT inlet and outlet (in inches).

(****) Standard Shaft Seals have carbon on ceramic faces and 316 SS components.

NOTE: Driver data is subject to change without notice; see label on driver for specifications and wiring information.
Manufacturer reserves the right to change specifications without notification.

SHURflo 316 Stainless Steel Rotary Close-Coupled External Gear Pumps

Dimensions

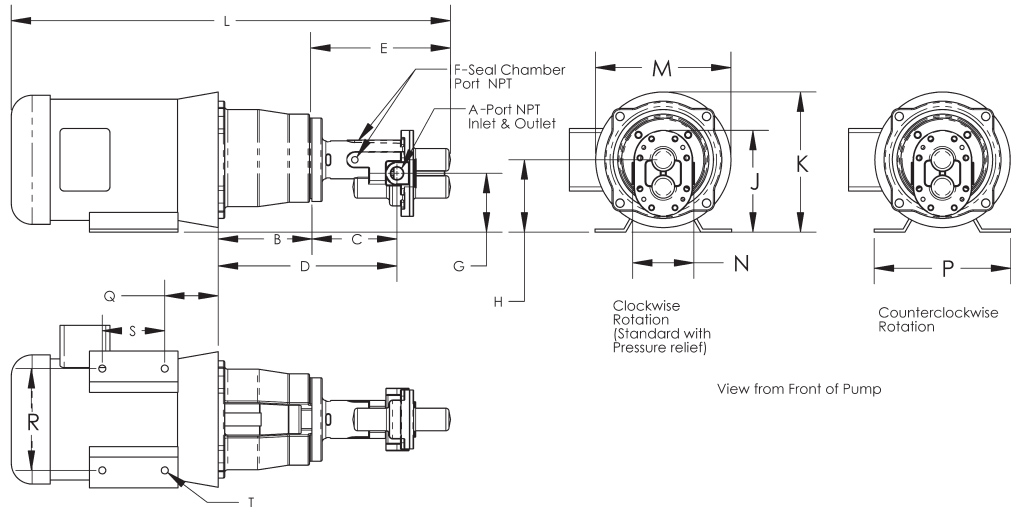

Figure 1

Model No.	Port			Dimensions (in inches)															
	A*	B	C	D	E	F*	G**	H**	J**	K**	L**	M**	N	P**	Q**	R**	S**	T**	
GMSV2A†, GMSV2A3T, GMSV2A33T	3/8	4.50	4.12	8.58	6.67	1/8	2.85	3.50	4.91	6.32	21.73	6.59	3.00	6.50	2.63	4.88	3.00	0.34	
GMST2A†, GMST2A3T, GMST2A33T																			
GMSV4A†, GMSV4A5T, GMSV4A53T	1/2	4.50	4.90	9.35	7.46	1/8	2.75	3.50	5.00	6.32	25.12	6.59	3.50	6.50	2.63	4.88	3.00	0.34	
GMST4A†, GMST4A5T, GMST4A53T																			
GMSV6C†, GMSV6C7T, GMSV6C73T	1	4.50	5.88	10.10	9.08	1/8	2.50	3.50	5.39	8.75	28.46	8.47	4.40	9.00	2.75	7.50	4.50	0.41	
GMST6C†, GMST6C7T, GMST6C73T																			

(†) Pump head only (motor not included).

(*) Standard NPT (female) pipe thread inlet and outlet (in inches).

(**) This dimension may vary due to motor manufacturer's specifications.

NOTE: All dimensions have a tolerance of (+ or -) 1/8".

Manufacturer reserves the right to change dimensions without notification.

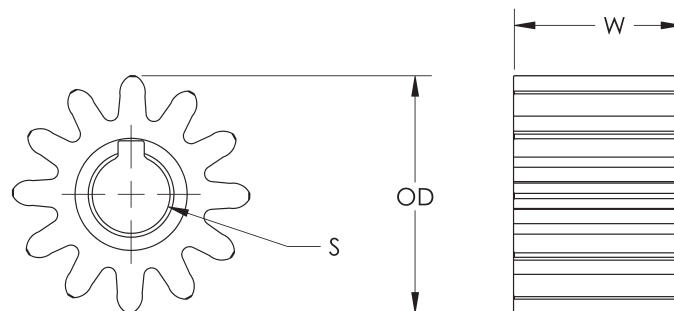

Gear Part Numbers and Dimensions (in inches)

Gear-Ryton (PPS) Black Spur	13879	12764	13883
Gear Outside Diameter (OD)	1.50	1.75	2.33
Gear Width (W)	0.75	1.25	1.50
Shaft Size (S)	0.50	0.63	0.79

PPS (Polyphenylene Sulfide)

NOTE: Manufacturer reserves the right to change dimensions without notification.

Figure 2 - Gear Identification and Dimension Chart

Viton Models GMSV2A, GMSV4A, GMSV6C, GMSV2A3T, GMSV2A33T, GMSV4A5T, GMSV4A53T, GMSV6C7T and GMSV6C73T Teflon® Models GMST2A, GMST4A, GMST6C, GMST2A3T, GMST2A33T, GMST4A5T, GMST4A53T, GMST6C7T and GMST6C73T

⚠ WARNING Check motor. It may be equipped with an automatic

resetting thermal protector and may restart unexpectedly (see specifications chart). Protector tripping is an indication of motor overloading as a result of operating the pump at too high a pressure (over 125 PSI), too high of viscosity, too high of specific gravity, excessively high or low voltage, inadequate wiring, incorrect motor connections, too small a motor (sized incorrectly, not enough HP), or a defective motor or pump.

Do not handle pump with wet hands or when standing in water. Failure to follow the General Safety Information and all warnings could result in fatal electrical shock!

Assembly (If pump and motor are pre-assembled, skip assembly.)

If a pump head needs to be coupled to an electric motor, then the following procedure should be followed. (See Figures 3 and 4.) First, install one of the two coupling halves and key on the pump shaft and tighten the set screw. The shaft end should be even or slightly recessed from the coupling half (approximately 1/8"). The other coupling half must be installed on the motor shaft. To do this, it should be placed on the shaft with the key, with the shaft recessed approximately 1/2". The set screw is not yet tight-

ened. It is necessary to establish a gap between the coupling halves of approximately .02" to .05" (See Figure 4). A thin piece of cardboard or a piece of paper folded up will work fine to set this gap. The pump is placed into position on the motor and the position of the motor coupling half is established using the piece of thin cardboard or other gauge material. The motor coupling half is tightened. The pump is removed, the coupling spider (rubber piece) is placed into position, and the pump bolted to the motor using the four bolts.

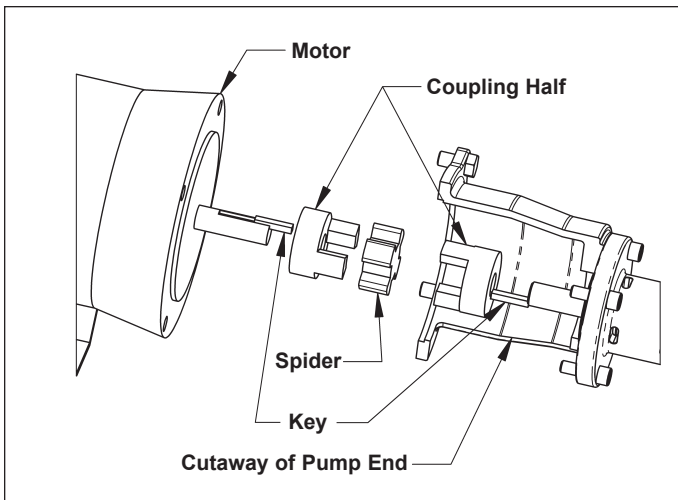

Figure 3 - Pump Motor Assembly

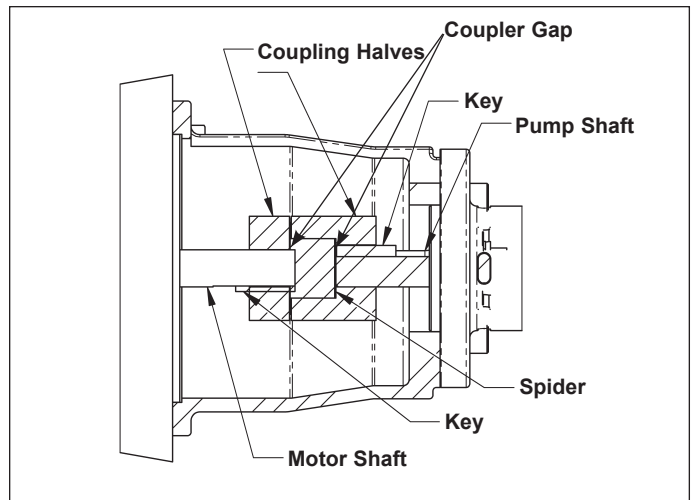

Figure 4 - Assembly Coupler

SHURflo 316 Stainless Steel Rotary Close-Coupled External Gear Pumps

Installation

IMPORTANT: In any installations where property damage and/or personal injury can occur when the pump is not operating due to power outages, discharge line freezing, or any other reason, a back-up system(s) and/or warning system(s) should be used.

In order to safely use this product, familiarize yourself with this pump and also with the liquid (chemical, etc.) that is going to be pumped through the unit. This pump is not suitable for many liquids.

1. Locate the pump as close to the liquid source as possible, making the suction line as short and direct as possible.

PIPING

SUCTION

2. Avoid excessive lengths or number of fittings and bends in the suction line.
3. Attach suction line to suction inlet (See Figure 1 for proper rotation).
4. It is recommended that same size pipe as pump ports be used or, in cases requiring lengthy piping, the next larger size pipe be used.
5. If suction lift is greater than what is indicated in the performance chart, attach a foot valve below liquid level at end of suction line to ensure positive priming. Also note: If fluid specific gravity is greater than 1.4 or viscosity greater than 500 SSU, a foot valve is also recommended.

NOTE: If a foot valve (or check valve) is not used in the suction line, it may be necessary to refill the pump every time the unit is stopped and you wish to restart the pump. This depends on the length of time between starts and whether or not the gears are wet enough to close cavities

to affect a prime.

6. If solid contaminants are suspected in a liquid, place a filter in the suction line.
7. Be certain all suction piping connections are airtight.

NOTE: Assure airtight pipe connections with the use of a pipe joint sealant.

DISCHARGE

8. Attach discharge piping to the discharge outlet.

▲ WARNING *Support pump and piping during assembly and after installation.*

Failure to do so may cause piping to break, pump to fail, motor bearing failures, etc., all of which can result in property damage and/or personal injury.

NOTE: Should the pump need to be self-draining, the pump head should be mounted in the vertical position with the suction port facing down. When pumping high viscosity fluids, the vertical position can be used with the suction port facing up and the pump mounted under the source. Increasing the suction pipe size and eliminating bends and elbows also assists in pumping high viscosity fluids. Max. viscosity is 500 SSU at 1725 RPM.

9. If a shut-off valve or handgun is required in discharge line, provide a pressure relief valve for pump protection.

▲ WARNING *Shutting off discharge without providing pressure relief can cause extreme overpressure which can result in pump and/or motor failure. Do not exceed 125 PSI pump or system pressure.*

10. Operation under shut-off discharge conditions will overheat and damage pump.

NOTE: Globe valve or other restrictive valves should not be used as shut-off mechanism as they are restrictive in

nature and will seriously affect pump performance.

11. After all piping and controls (not supplied with unit) have been installed, unit is ready for operation.

Operation

▲ CAUTION *Do not run pump dry, as permanent damage to the pump*

gears, seal, and bearings will result. Suction pressure should never be greater than the discharge pressure.

1. All pumps must be primed before start-up and the seal chamber needs

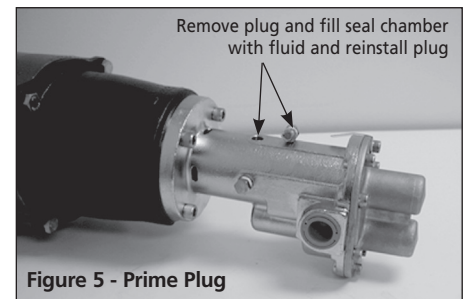

Figure 5 - Prime Plug

to be filled (See Figure 5). Never operate a pump unless it is secured to a solid foundation and all safety shields are installed.

Upon start-up, maintain a minimum of 15 PSI (1 BAR) operating pressure on the pump. This will allow any remaining air to be driven from the seal chamber and will ensure liquid circulation to the mechanical seal.

2. Gear pumps are built to very close tolerances and this tolerance must not be altered. The liquids must, therefore, be free of all abrasives. Sand, silt, wettable powders, etc. must be avoided.
3. When pumping a more viscous (beyond 500 SSU) liquid; a slower speed, a larger pipe size pump, and possibly a larger motor should be selected.

**Viton Models GMSV2A, GMSV4A, GMSV6C, GMSV2A3T, GMSV2A33T, GMSV4A5T, GMSV4A53T, GMSV6C7T and GMSV6C73T
Teflon® Models GMST2A, GMST4A, GMST6C, GMST2A3T, GMST2A33T, GMST4A5T, GMST4A53T, GMST6C7T and GMST6C73T**

NOTE: See performance chart for Max. Torque.

4. Recheck motor and pump rotation. Pump rotation is by-directional (See Figure 1).

PRESSURE RELIEF VALVE

5. Standard models do not include a pressure relief valve. If discharge is going to be shut off, an external pressure relief valve should be installed.

GEAR PUMP GASKET ADJUSTMENT FOR TEMPERATURE (See Appendix 1)

6. For operation in fluid temperatures above 120° F, stainless steel pump models must have the gasket thickness adjusted. Use Appendix 1 to identify pump, temperature and gasket recommendations for adjusting the cover clearance prior to operation in elevated temperatures or viscosities above 500 SSU.

CAUTION Failure to adjust pump cover clearances for operating temperatures above 120° F. will result in severe pump and/or motor damage.

NOTE: When pumping fluids of high viscosity (>500 ssu), the required torque and HP can be reduced by adding a

gasket for increased gear clearance.

MECHANICAL SEAL FLUSH INSTALLATION OPTIONS

7. These stainless steel pumps are equipped with mechanical seals and have been designed with flush ports because mechanical seals require cooling lubrication for long life.

a. For fluids with viscosities less than 2000 SSU, a flush is not necessary, but the seal cavity must be pre-filled with either the operating fluid or a neutral fluid. This is to ensure seal cooling and lubrication during start-up (See Figure 5).

CAUTION Failure to provide initial seal prime can result in the mechanical seal overheating with resulting repair costs.

b. For high viscosity fluids, a flush will be necessary. The seal must be cooled and lubricated by a fluid. In the case of high viscosity fluids, due to the precision clearances between the gear teeth and the stainless steel body, highly viscous fluids will not be able to adequately relieve the air in the

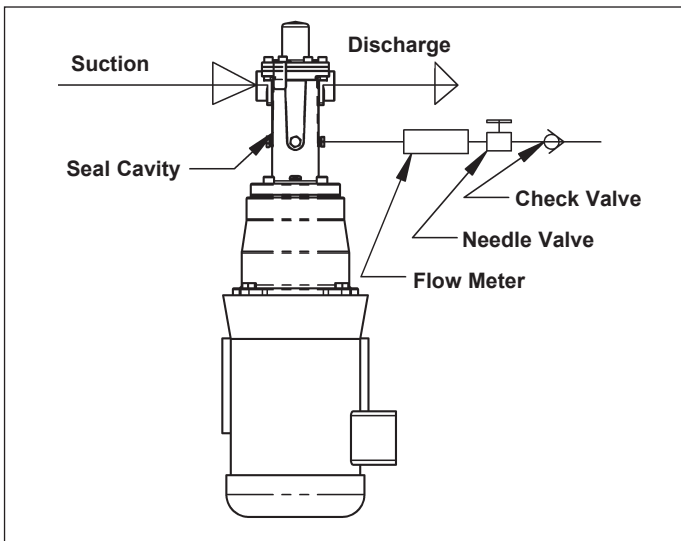

Figure 6 - External Flush

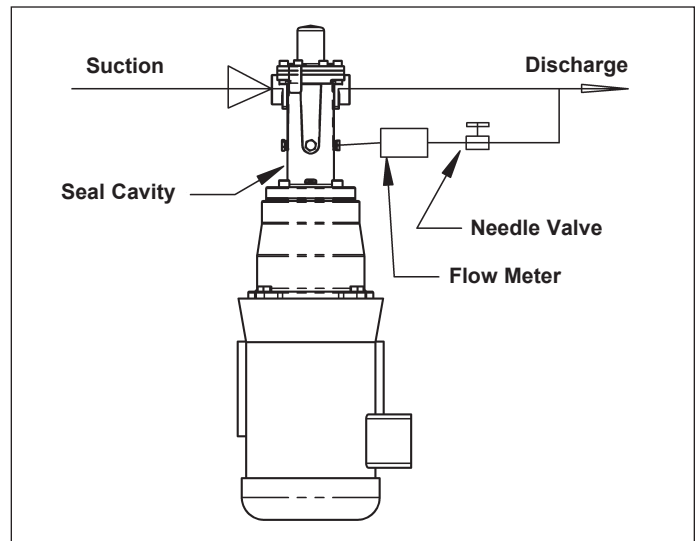

Figure 7 - Internal Flush

SHURflo 316 Stainless Steel Rotary Close-Coupled External Gear Pumps

seal cavity on start-up. The dry

running of a mechanical seal will cause rapid failure. A flush must be provided for fluids with a viscosity of greater than 2000 SSU.

CAUTION Pumping fluids with viscosities greater than 2000 SSU requires

flushing the seal chamber during operation, otherwise seal damage will occur.

EXTERNAL FLUSH

An external flush system is typically recommended for applications where crystallization build-up on the seal is possible. Some dilution of the working material must be acceptable to use an external flush system.

The external flush system (See Figure 6 for typical installation) is commonly used with liquids where city water can be used as the neutral flush fluid. City water is taken from an external source such as a tap, hose, or special plumbing fixture and is regulated into the seal cavity by means of a needle valve and flow meter. Use of an anti-siphon check valve is required.

Operation (Continued)

WARNING It is essential that an anti-siphon check valve be installed

between the pump and the city water supply to prevent any back flow from possibly contaminating the city water supply. Failure to do so could result in contamination of the water supply with consequential damages. Manufacturer assumes no responsibility for failure of user in not providing safeguards to city water systems.

Step 1: Locate appropriate city water supply and install anti-siphon check valve.

Step 2: Use appropriate pipe nipple to reduce piping to 1/8".

Step 3: Install appropriate needle valve and flow meter.

Step 4: Connect piping to one of three available seal flush ports on pump.

Step 5: Adjust needle valve to achieve desired flow to seal cavity (recommended 1 to 3 GPH).

INTERNAL FLUSH

Similar to above but internal supply (See Figure 7 for typical installation). Typically recommended for high viscosity applications ensuring lubrication to the mechanical seal.

In an internal flush system, the fluid is taken from the discharge and regulated from 1 to 3 GPH (Gallons Per Hour) to the seal cavity by means of a flow meter and needle valve.

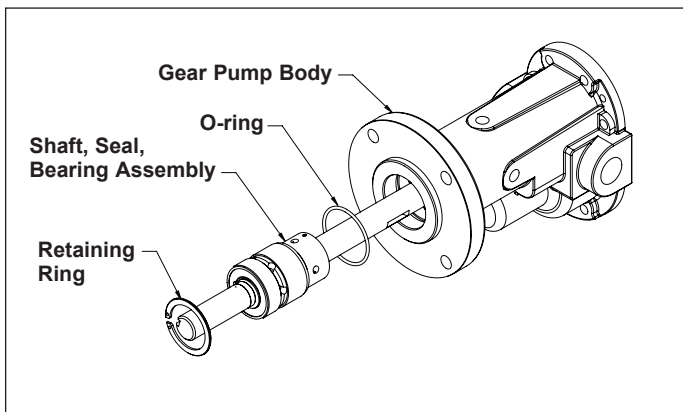

Figure 8 - Shaft, Seal and Bearing Assembly

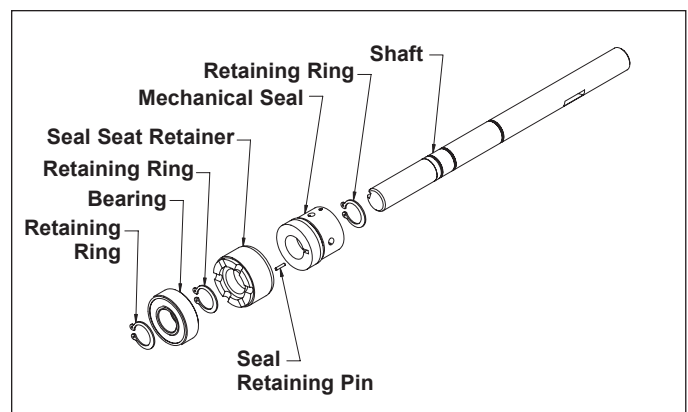

Figure 9 - Shaft, Seal and Bearing Assembly (detailed view)

Viton Models GMSV2A, GMSV4A, GMSV6C, GMSV2A3T, GMSV2A33T, GMSV4A5T, GMSV4A53T, GMSV6C7T and GMSV6C73T Teflon® Models GMST2A, GMST4A, GMST6C, GMST2A3T, GMST2A33T, GMST4A5T, GMST4A53T, GMST6C7T and GMST6C73T

Step 1: Select a T pipe coupling that is consistent with discharge pipe size and material. Couple to discharge piping.

Step 2: From this coupling, attach a needle valve with appropriate nipple, reducing to 1/8" pipe or tube. Install appropriate flow meter.

Step 3: Connect 1/8" pipe or tube to one of three available seal cavity flush ports.

Step 4: Adjust needle valve to desired flow into seal cavity (recommended 1 to 3 GPH).

CAUTION For alternate flush systems for hazardous fluid applications, hot liquid transfer, and those not addressed in this booklet, consult a qualified fluid handling specialist for assistance in specifying and installing flush systems according to local, state and federal environmental laws.

GEAR SPEED REDUCER OPTIONS

A gear reducer can be directly mounted between a standard pump and motor combination. Gear speed reducers are available for applications with high specific gravity, or when viscosities are greater than 500 SSU, using a standard 1725 RPM motor (See Appendix 2). The pump relationship between volume (GPM), pressure (PSI), speed (RPM), viscosity, specific gravity and horsepower is shown on performance chart in

Shurflo Motor Manual form L-4082.

8. Unit is ready for operation.

Maintenance

WARNING Make certain that the power source is disconnected before

attempting to service or disassemble any components!

If the power disconnect is out of sight, lock it in the open position and tag to prevent application of power.

CLEANING

Clean the suction line filter at regular intervals.

ELECTRIC MOTOR

Properly selected and installed, electric motors are capable of operating for years with minimal maintenance. Periodically clean dirt accumulations from open-type motors, especially in and around vent openings, preferably by vacuuming (avoid imbedding dirt in windings). Oil and maintain as recommended by motor manufacturer.

GENERAL

Check the pump to motor shaft coupler alignment at regular intervals.

Periodically check that electrical connections are tight. Pump should be drained if placed in an area that is subject to freezing temperatures and should not be operated until temperature permits.

To store the pump, place a small quan-

tity of light oil or some other storage preservative compatible with your application in the pump and rotate the shaft very slowly to work the oil throughout the gears and the body.

PUMP REPAIR

DISASSEMBLY

(Refer to Figure 13 for Reference Numbers and Figures 3, 8, 9, 10, 11 & 12 for detailed seal and shaft assemblies.)

1. Remove pump from motor.

a. Remove the coupler half from the pump (See Figure 3). The motor coupler half does not need to be removed unless motor is being replaced.

2. Gear Removal

a. Remove cover plate (Ref. No. 2) (held by eight screws) and gasket (Ref. No. 3) if needed. Gently tap cover plate with rubber mallet to free it from dowel pins. Once cover is removed, the idler shaft and gear assembly can be pulled out of pump body (Ref. No. 12).

b. Remove the idler gear (Ref. No. 6) from the shaft (Ref. No. 7) by removing retaining rings (Ref. No. 5), then slide gears off the shaft end.

c. The drive gear (Ref. No. 6) can be pulled out. Before drive shaft (Ref. No. 9) can be removed from body (Ref. No. 12), remove

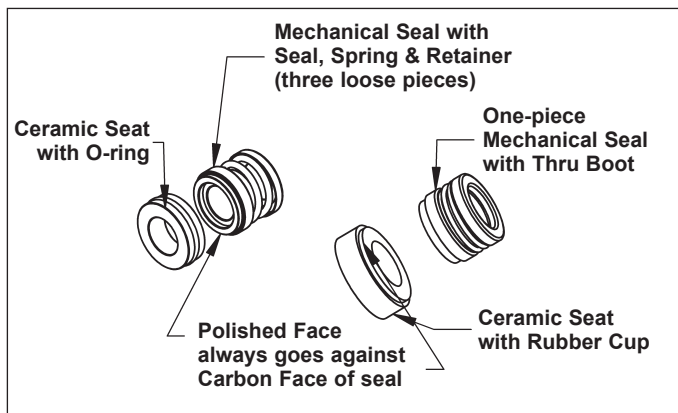

Figure 10 - Seal Types and Parts Identification

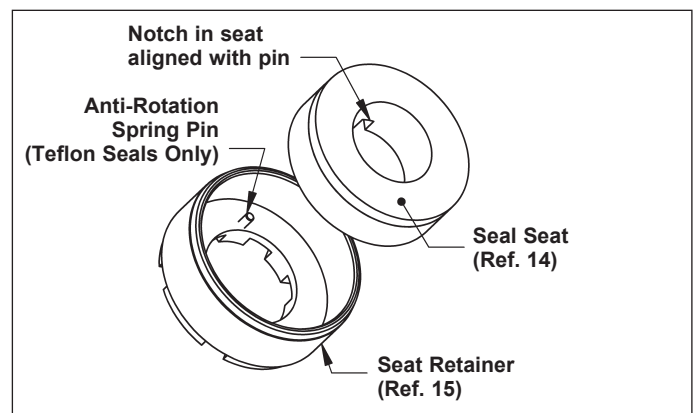
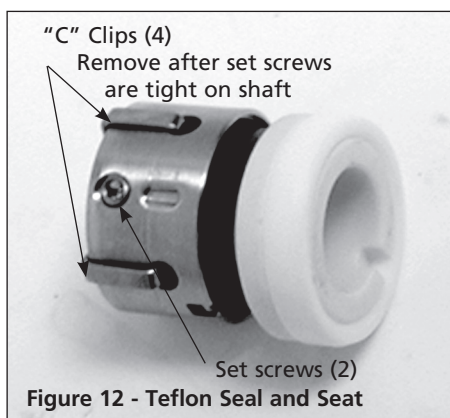

Figure 11 - Seal Seat and Retainer Assembly

SHURflo 316 Stainless Steel Rotary Close-Coupled External Gear Pumps

woodruff key (Ref. No. 8) by gently tapping key with drift pin. (Do not damage key or keyway upon removal.)

3. From the drive shaft end of the gear pump, remove the internal snap ring (Ref. No. 13) from the body (Ref. No. 12). The drive assembly, which consists of the drive shaft (Ref. No. 9), seal assembly (Ref. Nos. 18 & 19), seat retainer (Ref. No. 16), bearing (Ref. No. 15) and retaining rings (Ref. No. 14), can now be removed from the unit (See Figure 8). Also remove the internal o-ring



(Ref. No. 20) from the body.

REASSEMBLY

(Refer to Figure 13 for Reference Numbers and Figures 3, 8, 9, 10, 11 & 12 for detailed seal and shaft assemblies.)

1. Shaft/Seal Assembly

- a. Install inside o-ring (Ref. No. 20) into body (Ref. No. 11). Lubricate with water.
- b. There are two possible standard types of seals. One style, the seal is one piece while the other style

has a seal boot, spring and spring retainer. The seal seats can also be of two styles; one has a rubber boot and the other has an o-ring. Identify which type you have (See Figure 10). (For the Teflon® seal, see the following note and Figure 12.)

- c. Refer to assembling components on drive shaft (See Figure 9). When installing the seal on the shaft, wet with water and be cautious when sliding it into position. The spring retaining washer and spring are behind the seal with the carbon ceramic facing towards the keyed end of drive shaft (See Figure 9).
- d. Press seal seat into the seal retainer (See Figure 11) using water as a lubricant. The white shiny ceramic face should be visible after pressing the seal into the seal retainer. It is recommended to use a cardboard washer or wood dowel when pushing the seal seat into the seal seat retainer. Any scratches, dirt, or fingerprints on the carbon ceramic faces will cause the seal to leak. The seal seat is stationary in the pump, while the seal on the shaft rotates, providing for the sealing surface.

NOTE: When installing the seat for the Teflon seal, an anti-rotation pin must be installed into the seat retainer. The anti-rotation pin (Ref. No. 25) is a small spring pin which must be installed into the seat retainer in the small hole. About 1/8" to 3/16" of the pin should be exposed inside of the seat retainer (Figure 11). The seal seat is then installed into the seat retainer.

To order parts, contact a SHURflo Distributor or Order Direct.
Distributors can be found at www.shurfloindustrial.com.

Please provide following information:

- Model number
- Serial number (if any)
- Part description and number as shown in parts list

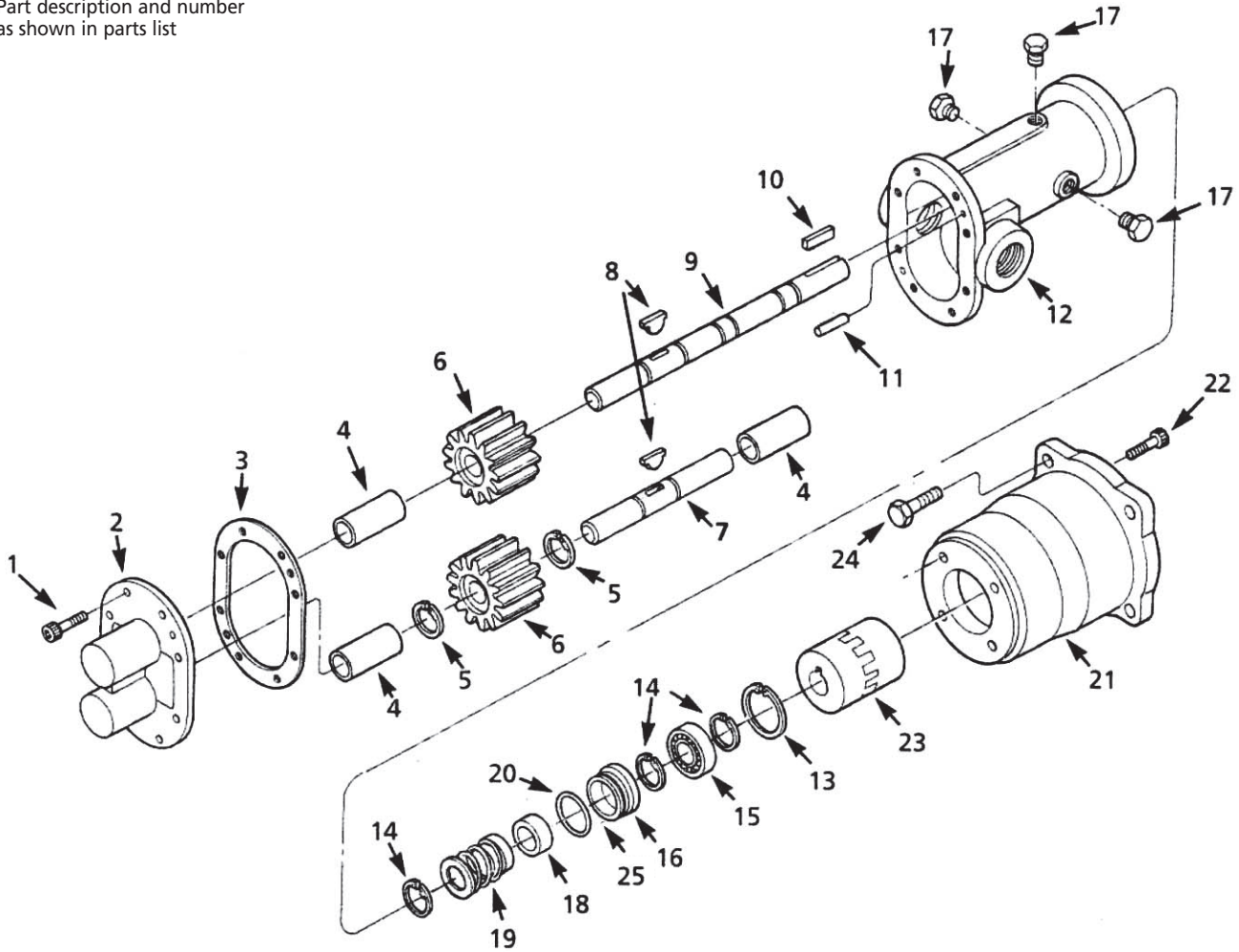

Figure 13 – Repair Parts Illustration

SHURflo 316 Stainless Steel Rotary Close-Coupled External Gear Pumps

Repair Parts List

Ref. No.	Included In Kit	Description	Part No. for Viton Pump Models			Part No. for Teflon Pump Models			Qty.
			GMSV2A† GMSV2A3T GMSV2A33T	GMSV4A† GMSV4A5T GMSV4A53T	GMSV6C† GMSV6C7T GMSV6C73T	GMST2A† GMST2A3T GMST2A33T	GMST4A† GMST4A5T GMST4A53T	GMST6C† GMST6C7T GMST6C73T	
1		Soc. Hd. Screw	19888	19888	19888	19888	19888	19888	8
2		Cover - 316 SS***	218705	218715	218725	218705	218715	218725	1
3	1	Gasket - Graphoil	22115	22116	19931	22115	22116	19931	1
Optional		High Temperature Gasket Kit	24436	23956	23982	24436	23956	23982	
4		Bushing - Carbon Graphite	21222	21223	21179	21222	21223	21179	3
5	1, 2	Ext. Ret. Ring	21094	12840	21063	21094	12840	21063	2
6	1, 2, 3, 4	Gear - Ryton PPS	13879	12764	13883	13879	12764	13883	2
7	2	Idle Shaft - 316 SS	21876	21877	21878	21876	21877	21878	1
8	1, 2, 3,4	Woodruff Key - 316 SS	21301	12841	12841	21301	12841	12841	2
9	3, 4	Drive Shaft - 316 SS	21873	21874	21875	21873	21874	21875	1
10	3, 4	Square Key - 316 SS	21436	21437	22428	21436	21437	22428	1
11		Dowel Pin - 316 SS	21056	21056	21056	21056	21056	21056	2
12		Body - 316 SS***	218675	218685	218695	218675	218685	218695	1
13	3, 4	Int. Ret. Ring	04303	04259	19942	04303	04259	19942	1
14	3, 4	Ext. Ret. Ring	21093	12582	15952	21093	12582	15952	3
15	3, 4	Ball Bearing	04306	04257	19988	04306	04257	19988	1
16	3, 4	Retainer - 316 SS	21969	21968	22144	21969	21968	22144	1
17		Pipe Plug - 316 SS	24441	24441	24441	24441	24441	24441	3
*18/19	3, 4	Mech. Seal/Seal Seat (Std.)	247665	247675	247685	246125	246135	246145	1
Optional		Mech. Seal/Seal Seat (Viton)	Std.	Std.	Std.	247665	247675	247685	
**Optional		Mech. Seal/Seal Seat (Teflon®)	246125	246135	246145	Std.	Std.	Std.	
Optional		Mech. Seal/Seal Seat (Buna)	246045	246055	246065	246045	246055	246065	
20	3, 4	O-Ring (Std.)	22173	22174	22343	22191	22192	22193	1
Optional		O-Ring (Viton)	Std.	Std.	Std.	22173	22174	22343	
Optional		O-Ring (Teflon®)	22191	22192	22193	Std.	Std.	Std.	
Optional		O-Ring (Buna)	21303	21913	23447	21303	21913	23447	
21		Adapter - Cast Iron	21866	21866	21979	21866	21866	21979	1
22		Soc. Hd. Bolt	22362	22362	22362	22362	22362	22362	4
23		Coupling	21885	21886	22184	21885	21886	22184	1
24		Cap Screw	13309	13309	13309	13309	13309	13309	4
**25		Anti-Rotation Pin	NA	NA	NA	22537	22537	22537	1
26		Motor (3/4 HP, 1 PH TEFC) (For Pump Model GMSV2A3T)	215945	Optional	Optional	215945	Optional	Optional	1
27		Motor (3/4 HP, 3 PH TEFC) (For Pump Model GMSV2A33T)	221465	Optional	Optional	221465	Optional	Optional	1
28		Motor (1-1/2 HP, 1 PH TEFC) (For Pump Model GMSV4A5T)	Optional	215965	Optional	Optional	215965	Optional	1
29		Motor (1-1/2 HP, 3 PH TEFC) (For Pump Model GMSV4A53T)	Optional	221485	Optional	Optional	221485	Optional	1
30		Motor (3 HP, 1 PH TEFC) (For Pump Model GMSV6C7T)	Optional	Optional	246465	Optional	Optional	246465	1
31		Motor (3 HP, 3 PH TEFC) (For Pump Model GMSV6C73T)	Optional	Optional	221505	Optional	Optional	221505	1
3, 5, 6, 8		Kit 1 - Gear Repair Kit	22278	22279	22280	22278	22279	22280	
5, 6, 7, 8		Kit 2 - Idler Shaft/Gear Assy. Kit	22437	22438	22439	22437	22438	22439	
6, 8, 9, 10, 13, 14, 15, 16, 18/19, 20		Kit 3 - Dr. Shaft/Gear Assy. Kit (Viton or Teflon®)	22303V	22304V	22305V	22303T	22304T	22305T	
6, 8, 9, 10, 13, 14, 15, 16, 18/19, 20		Kit 4 - Dr. Shaft/Gear Assy. Kit (Buna)	22303B	22304B	22305B	22303B	22304B	22305B	

NOTE: For operating temperatures greater than 120° F. or high viscosities, gasket thickness must be adjusted.
 (†) Pump head only (no motor).
 (*) Mech. seal and seat sold as set only (Ref. Nos. 18 & 19). Teflon® and Viton seals consist of carbon ceramic faces with 316 SS components.
 (**) When ordering the Teflon® seal, Teflon® Seal Anti-Rotation Pin is required (Ref. No. 25).
 (***) Body and cover supplied with carbon graphite bushings installed.
 When converting to a different seal/seat material, remember to order the o-ring (Ref. No. 20) of the same material.
 SS = Stainless Steel
 Ryton = PPS (Polyphenylene Sulfide)
 TEFC = Totally-Enclosed Fan-Cooled Motor
 Kits 2 - 4 do not ship with gaskets.

**Viton Models GMSV2A, GMSV4A, GMSV6C, GMSV2A3T, GMSV2A33T, GMSV4A5T, GMSV4A53T, GMSV6C7T and GMSV6C73T
Teflon® Models GMST2A, GMST4A, GMST6C, GMST2A3T, GMST2A33T, GMST4A5T, GMST4A53T, GMST6C7T and GMST6C73T**

Appendix 1 - Gear Pump Gasket Adjustment for Temperature

Gear pump is factory assembled to operate within a temperature range of 70° – 120° F (20° – 50° C). For temperatures outside this range, please see the table below for your series and port size pump.

NOTE: Always refer to the original owner’s manual repair and maintenance sections on pump disassembly and assembly for more detailed instructions.

NOTE: When pumping fluids of high viscosity (>500 SSU), the required torque and HP can be reduced by adding a gasket for increased gear clearance.

Gasket Installation Instructions (refer to assembly diagram below):

1. Turn off power to pump, turn off inlet and outlet valves, and relieve pressure in lines.
2. Allow pump to cool.
3. Remove cover screws (1), cover (2) and gasket (3). Be sure to mark

proper orientation of cover and pump body.

4. Replace gaskets (3) per instructions listed in table.
5. Replace cover (2) and cover screws (1) according to orientation marked in step 3.
6. Tighten cover screws (1) in sequence listed on diagram. Use torque specifications listed in table.

Kit PN	NPT Port Size	Temp Range	Instructions	Bolt Torque	
Stainless Steel Gear Pump Series	24436	Pumps with 3/8" ports	Up to 120° F (50° C)	Use standard graphoil gasket as shipped (0.010" thick)*	75 in.-lbs. (8.5 N-m)
			120° F – 280° F (50° C – 138° C)	Use optional thicker (0.015") graphoil gasket	
	23956	Pumps with 1/2" ports	Up to 120° F (50° C)	Use standard graphoil gasket as shipped (0.010" thick)*	75 in.-lbs. (8.5 N-m)
				120° F – 280° F (50° C – 138° C)	
	23982	Pumps with 1" ports	Up to 70° F (20° C)	Use optional thinner (0.010") graphoil gasket	75 in.-lbs. (8.5 N-m)
			70° F – 120° F (20° C – 50° C)	Use standard graphoil gasket as shipped (0.015" thick)*	
120° F – 280° F (50° C – 138° C)			Use 2X optional thinner (for a total of 0.020") graphoil gasket		

***Standard Set-up**

Gear Pump Gasket Install Assembly

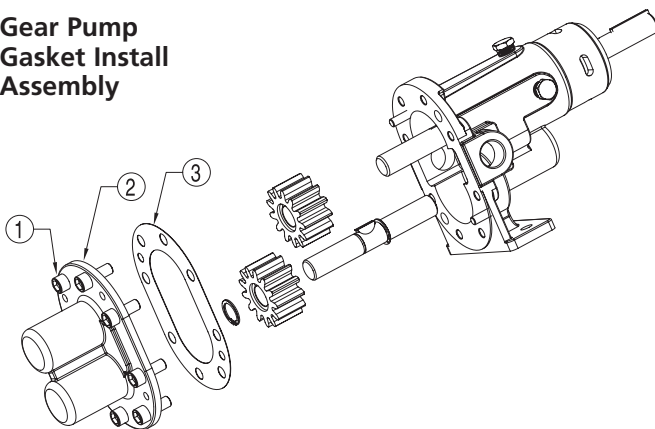

Bolt Tightening Sequence

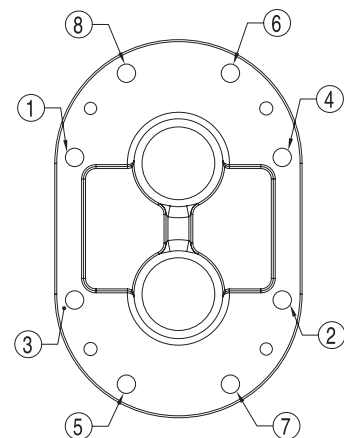

SHURflo 316 Stainless Steel Rotary Close-Coupled External Gear Pumps

Appendix 2 - Optional C-Flanged Pump Speed Gear Reducers

GEAR SPEED REDUCER OPTIONS

A gear reducer can be directly mounted between a standard pump and motor combination. Gear speed reducers are available for applications with high

specific gravity, or when viscosities are greater than 500 SSU, using a standard 1725 RPM motor. The pump relationship between volume (GPM), pressure (PSI), speed (RPM), viscosity, specific

gravity and horsepower is shown on performance chart in Shurflo Motor Manual form L-4082.

Model Number	Description	L*	M*	RPM Out**	Ship Weight (lbs.)
AGR56C600	Gear Reducer, 56C to 56C, 3.0 ratio	5.177	1.675	583	21
AGR56C900	Gear Reducer, 56C to 56C, 2.0 ratio	5.177	1.675	875	21
AGR56C1200	Gear Reducer, 56C to 56C, 1.5 ratio	5.177	1.675	1167	21
AGR145TC600	Gear Reducer, 145TC to 145TC, 3.0 ratio	5.625	2.875	583	29
AGR145TC900	Gear Reducer, 145TC to 145TC, 2.0 ratio	5.625	2.875	875	29
AGR145TC1200	Gear Reducer, 145TC to 145TC, 1.5 ratio	5.625	2.875	1167	29
AGR184TC600	Gear Reducer, 184TC to 184TC, 3.0 ratio	7.43	2.875	583	56
AGR184TC900	Gear Reducer, 184TC to 184TC, 2.0 ratio	7.43	2.875	875	56
AGR184TC1200	Gear Reducer, 184TC to 184TC, 1.5 ratio	7.43	2.875	1167	56

(*) L dimension (in inches) is length of the gear reducer. M dimension (in inches) is the offset of the reducer output centerline from the motor centerline. All reducers may be rotated in 90° increments, changing the orientation of the offset from top to side to bottom.

(**) Based on 1750 RPM motor speed.

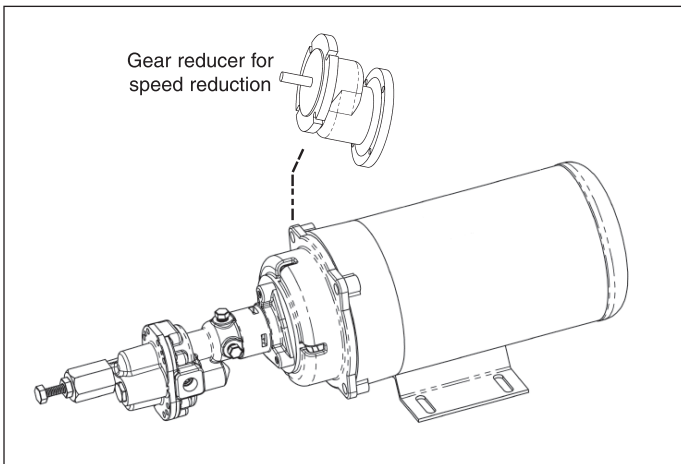

Disassemble Pump From Motor and
Insert Gear Reducer

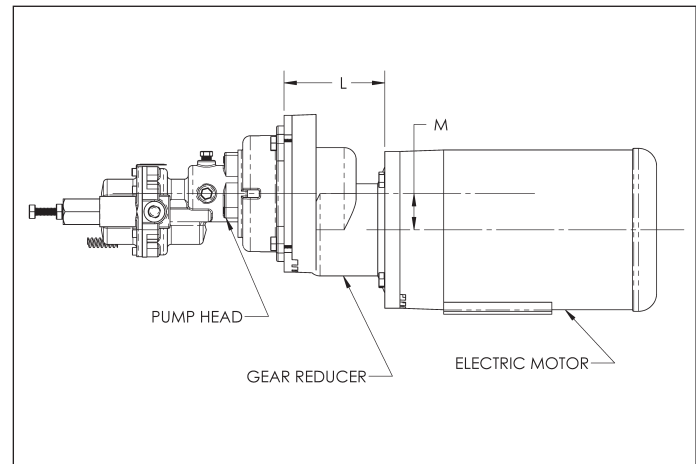

Gear Reducer Installed between Pump and Motor
(References L and M are dimensions in chart above.)

