



STRUCTURAL CH5821

DISTRIBUTOR ASSEMBLY INSTRUCTIONS
USED ON DST 5696, 5697, 5698, 5699

BOTTOM MOUNT HUB AND LATERAL SYSTEM 6" - 8" STRAIGHT THREAD

FRP TANKS

(21", 24", 30", 36") DIAMETER TANKS

STEP 1

Exploded view of Hub Assembly.

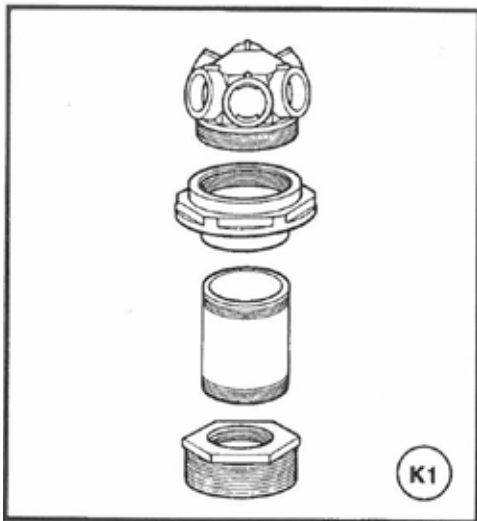

STEP 2

Parts shown in Step 1 are assembled (outside of tank) and inserted into tank opening.

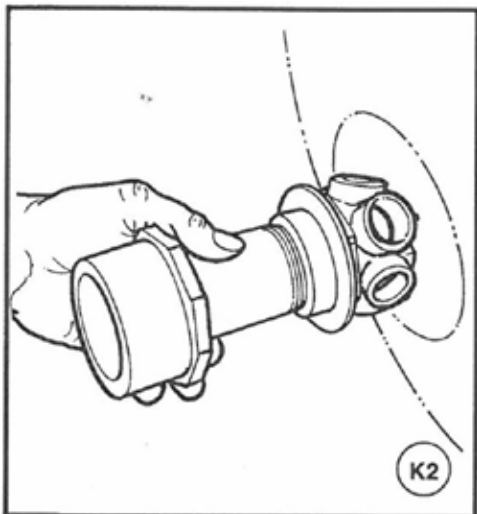

STEP 3

After assembly is inside the tank, rotate the assembly 90°. Hold Hub assembly with one hand, as shown, and assemble laterals by inserting and twisting clockwise.

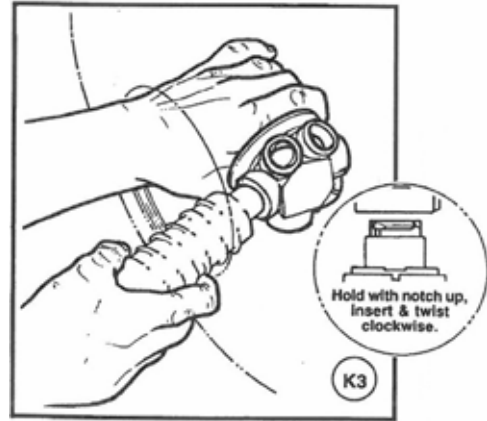

STEP 4

After all laterals are assembled, hold the assembly, as shown, and thread on the adaptor. Note: Be sure o-ring is attached and seated properly to adaptor. Fasten to tank with spanner wrench.

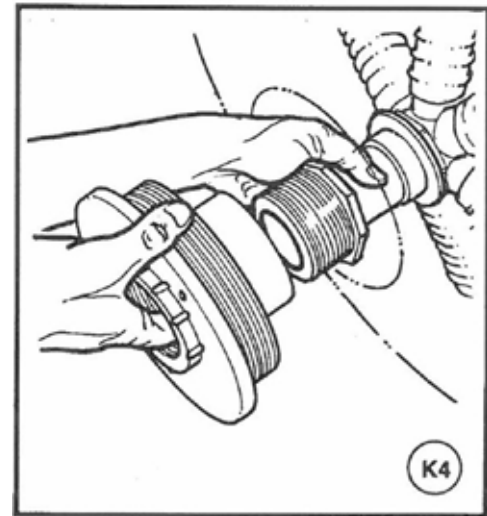

CALIFORNIA PROPOSITION 65 WARNING

⚠ WARNING: This product contains chemicals known to the State of California to cause cancer or birth defects or other reproductive harm.

For Structural Product Warranties visit:
Structural para las garantías de los productos visite: } waterpurification.pentair.com
Pour Structural garanties produit visitez le site :



WATER QUALITY SYSTEMS

5730 NORTH GLEN PARK ROAD, MILWAUKEE, WI 53209

P: 262.238.4400 | WATERPURIFICATION.PENTAIR.COM | CUSTOMER CARE: 800.279.9404 | tech-support@pentair.com

All Pentair trademarks and logos are owned by Pentair, Inc. or its affiliates. All other registered and unregistered trademarks and logos are the property of their respective owners. Because we are continuously improving our products and services, Pentair reserves the right to change specifications without prior notice. Pentair is an equal opportunity employer.

CH5821 REV B FE16 © 2016 Pentair Residential Filtration, LLC All Rights Reserved.