



STRUCTURAL CH5818

DISTRIBUTOR ASSEMBLY INSTRUCTIONS

USED ON DST 5672, 5673, 5674, 5675, 12201, 13492

TOP MOUNT HUB AND LATERAL SYSTEM

FLANGED COMPOSITE TANKS

(24", 30", 36", 42", 48", 63") DIAMETER TANKS

FRP TANKS

(30", 36") DIAMETER TANKS

STEP 1

Use length of 3" PVC pipe (longer than tank length), slip on 3" PVC female adaptor and bond with universal primer and cement.

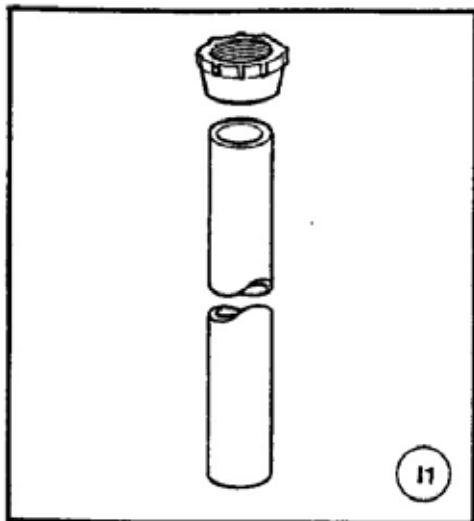

STEP 2

Exploded view of Hub assembly.

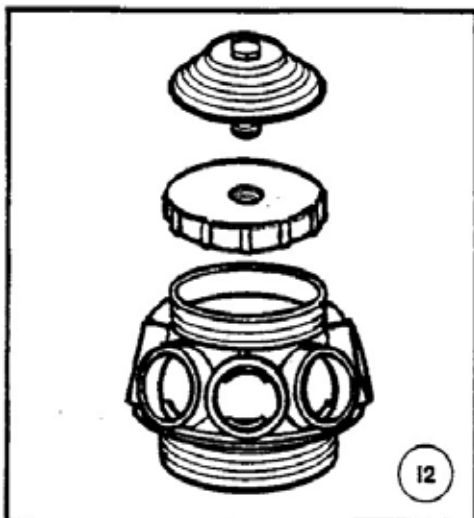

STEP 3

The Top Mount Hub Assembly is threaded on to the female adaptor of the assembly fixture and inserted into top opening. Allow to rest on side wall of tank. (As shown)

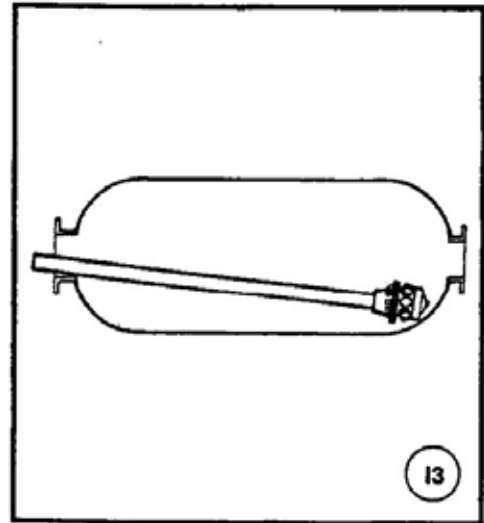

STEP 4

Insert laterals one at a time through bottom opening. Insert laterals into Hub and lock into place by turning clockwise. Install riser by screwing adaptor on to hub. Riser tube can now be cut to proper length to accommodate top mounted valve.

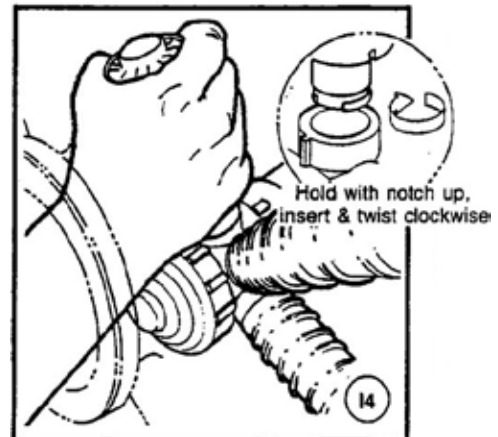

CALIFORNIA PROPOSITION 65 WARNING

▲ WARNING: This product contains chemicals known to the State of California to cause cancer or birth defects or other reproductive harm.

For Structural Product Warranties visit: }
Structural para las garantías de los productos visite: } waterpurification.pentair.com
Pour Structural garanties produit visitez le site : }



WATER QUALITY SYSTEMS

5730 NORTH GLEN PARK ROAD, MILWAUKEE, WI 53209

P: 262.238.4400 | WATERPURIFICATION.PENTAIR.COM | CUSTOMER CARE: 800.279.9404 | tech-support@pentair.com

All Pentair trademarks and logos are owned by Pentair, Inc. or its affiliates. All other registered and unregistered trademarks and logos are the property of their respective owners. Because we are continuously improving our products and services, Pentair reserves the right to change specifications without prior notice. Pentair is an equal opportunity employer.

CH5818 REV B FE16 © 2016 Pentair Residential Filtration, LLC All Rights Reserved.