



STRUCTURAL CH12161

DISTRIBUTOR ASSEMBLY INSTRUCTIONS
USED ON DST 10877

**TOP MOUNT
STACK DIFFUSER SYSTEM**
FOR 63" COMPOSITE TANK
WITH 16" MANWAY FLANGE

STEP 1

Install the o-ring into the 16" Manway Cover. Thread the top stack diffuser system to the Manway.

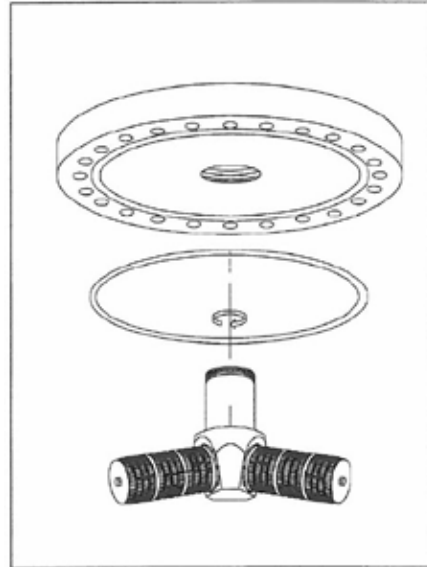

STEP 2

Install the adapter in the Manway and tighten the bolts in the manner shown above. **NOTE:** This can be assembled after filling.

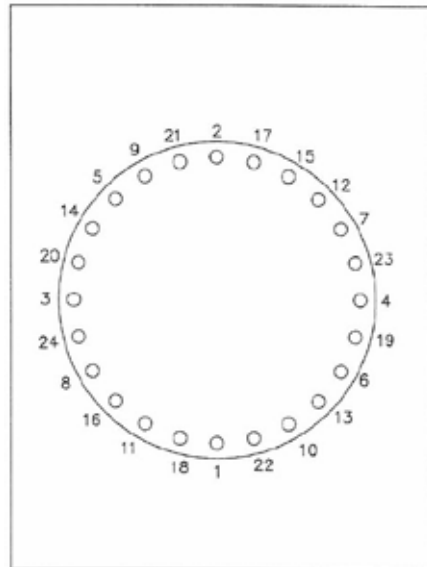

CALIFORNIA PROPOSITION 65 WARNING

▲ WARNING: This product contains chemicals known to the State of California to cause cancer or birth defects or other reproductive harm.

For Structural Product Warranties visit:
Structural para las garantías de los productos visite: } waterpurification.pentair.com
Pour Structural garanties produit visitez le site :



WATER QUALITY SYSTEMS

5730 NORTH GLEN PARK ROAD, MILWAUKEE, WI 53209

P: 262.238.4400 | WATERPURIFICATION.PENTAIR.COM | CUSTOMER CARE: 800.279.9404 | tech-support@pentair.com

All Pentair trademarks and logos are owned by Pentair, Inc. or its affiliates. All other registered and unregistered trademarks and logos are the property of their respective owners. Because we are continuously improving our products and services, Pentair reserves the right to change specifications without prior notice. Pentair is an equal opportunity employer.

CH12161 REV B FE16 © 2016 Pentair Residential Filtration, LLC All Rights Reserved.