



STRUCTURAL CH5856

DISTRIBUTOR ASSEMBLY INSTRUCTIONS
USED ON DST 5676, 5677, 15528, 15529

TOP AND SIDE MOUNT HUB AND LATERAL SYSTEM

HIGH FLOW FLANGED COMPOSITE TANKS
(30", 36", 42", 48") DIAMETER TANKS

STEP 1

Exploded view of Hub Components.

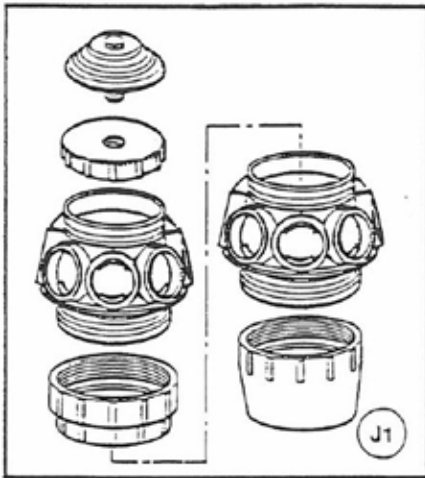

STEP 2

Assemble Hub, as shown, and insert assembly into flange opening.

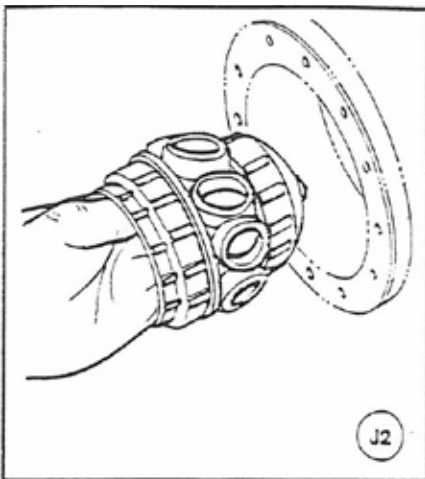

CALIFORNIA PROPOSITION 65 WARNING

⚠ WARNING: This product contains chemicals known to the State of California to cause cancer or birth defects or other reproductive harm.

STEP 3

After assembly is inside the tank, rotate the assembly 90°. Hold the Hub assembly with one hand, as shown, and assemble laterals by inserting and twisting clockwise.

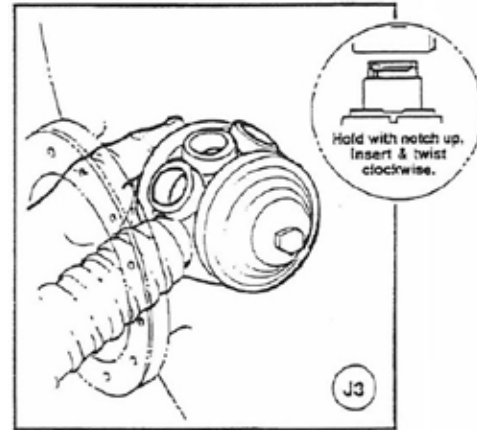

STEP 4

While holding Hub and lateral assembly No. 1, attach Hub assembly No. 2 with adaptor attached and go to (step 5).

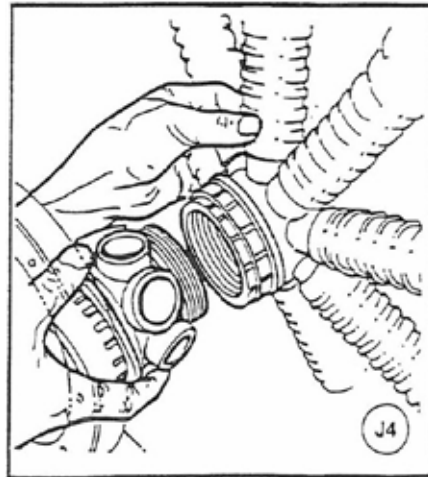

STEP 5

Hold Hub assembly with one hand and attach laterals as described in (step 3). After all laterals are assembled, bond pipe to adaptor using universal primer and cement.

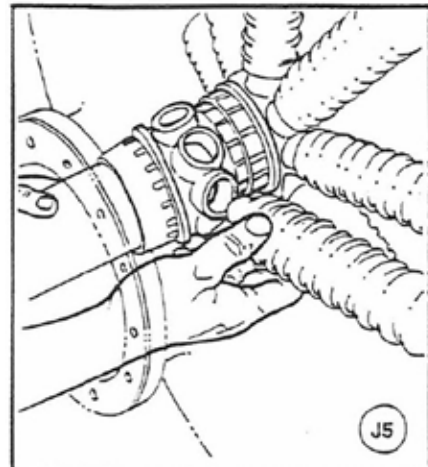

For Structural Product Warranties visit: }
Structural para las garantías de los productos visite: } waterpurification.pentair.com
Pour Structural garanties produit visitez le site : }



WATER QUALITY SYSTEMS

5730 NORTH GLEN PARK ROAD, MILWAUKEE, WI 53209

P: 262.238.4400 | WATERPURIFICATION.PENTAIR.COM | CUSTOMER CARE: 800.279.9404 | tech-support@pentair.com

All Pentair trademarks and logos are owned by Pentair, Inc. or its affiliates. All other registered and unregistered trademarks and logos are the property of their respective owners. Because we are continuously improving our products and services, Pentair reserves the right to change specifications without prior notice. Pentair is an equal opportunity employer.

CH5856 REV B FE16 © 2016 Pentair Residential Filtration, LLC All Rights Reserved.