



## STRUCTURAL CH12188

### DISTRIBUTOR ASSEMBLY INSTRUCTIONS

USED ON DST 5680-1, 5680-2

### TOP STACK DIFFUSER SYSTEM

FOR 21", 26", 30", 36", 42", 48", 63"

### COMPOSITE TANK WITH 6" SNA FLANGE

#### STEP 1

Install the pipe into the hub. Insert the hub through the 6" opening in the tank. Thread diffusers into the hub. Install the o-ring into the 6" SNA flange. Thread the top stack diffuser system into the 6" SNA flange.

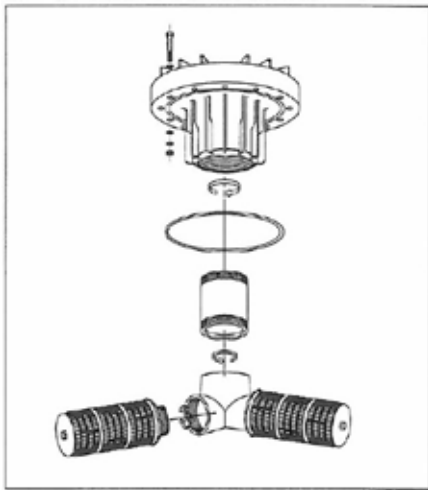

#### STEP 2

Assemble as shown.

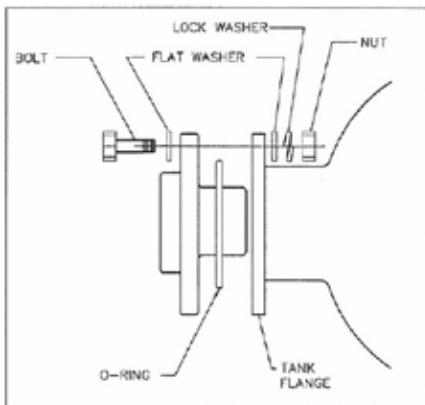

#### STEP 3

Using 1/2" wrenches, tighten 5/16" x 2-1/2 long bolts alternately, as shown, until the flanges are flush with each other and seal is obtained.

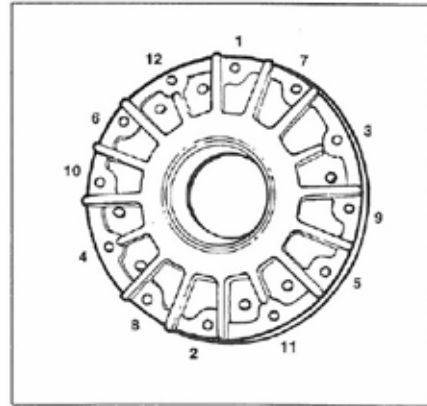

### **CALIFORNIA PROPOSITION 65 WARNING**

**▲ WARNING:** This product contains chemicals known to the State of California to cause cancer or birth defects or other reproductive harm.

For Structural Product Warranties visit: }  
Structural para las garantías de los productos visite: } [waterpurification.pentair.com](http://waterpurification.pentair.com)  
Pour Structural garanties produit visitez le site : }



**WATER QUALITY SYSTEMS**

5730 NORTH GLEN PARK ROAD, MILWAUKEE, WI 53209

P: 262.238.4400 | WATERPURIFICATION.PENTAIR.COM | CUSTOMER CARE: 800.279.9404 | tech-support@pentair.com

All Pentair trademarks and logos are owned by Pentair, Inc. or its affiliates. All other registered and unregistered trademarks and logos are the property of their respective owners. Because we are continuously improving our products and services, Pentair reserves the right to change specifications without prior notice. Pentair is an equal opportunity employer.

CH12188 REV B FE16 © 2016 Pentair Residential Filtration, LLC All Rights Reserved.