



STRUCTURAL CH5816

DISTRIBUTOR ASSEMBLY INSTRUCTIONS
USED ON DST 5679

TOP STACK DIFFUSER SYSTEM

FLANGED COMPOSITE TANKS

(18, 21", 24", 30", 36", 42", 48")

DIAMETER TANKS

STEP 1

Assemble diffuser to closure and thread together clockwise.

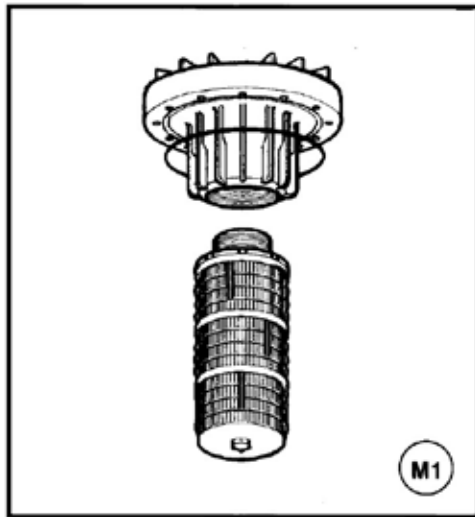

STEP 2

Be sure o-ring is assembled and seated properly to flange, then assemble to tank and tighten as specified in Figure M3.

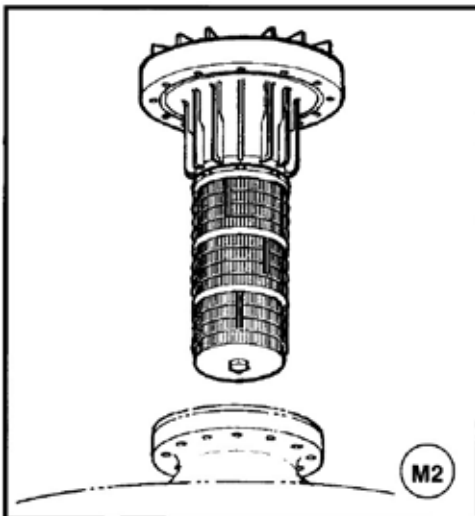

STEP 3

Using 1/2" wrenches, tighten 5/16" x 2-1/2" long bolts alternately, as shown, until the flange faces are flush with each other and seal is attained.

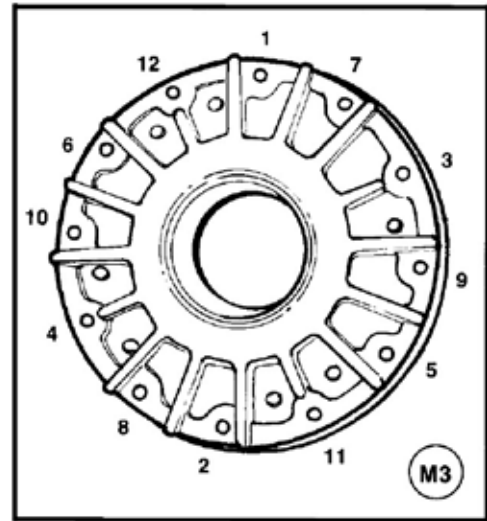

STEP 4

Assemble as shown.

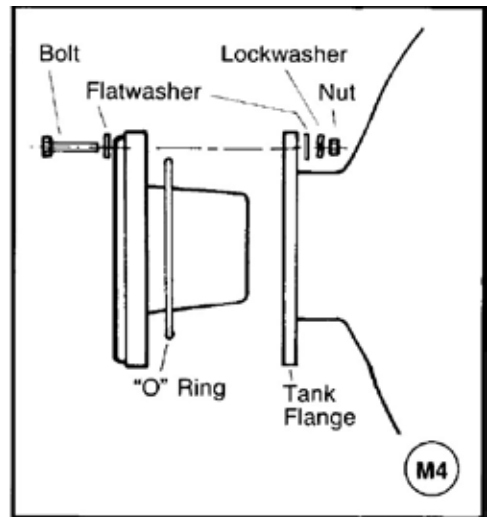

CALIFORNIA PROPOSITION 65 WARNING

⚠ WARNING: This product contains chemicals known to the State of California to cause cancer or birth defects or other reproductive harm.

For Structural Product Warranties visit: }
Structural para las garantías de los productos visite: } waterpurification.pentair.com
Pour Structural garanties produit visitez le site : }



WATER QUALITY SYSTEMS

5730 NORTH GLEN PARK ROAD, MILWAUKEE, WI 53209

P: 262.238.4400 | WATERPURIFICATION.PENTAIR.COM | CUSTOMER CARE: 800.279.9404 | tech-support@pentair.com

All Pentair trademarks and logos are owned by Pentair, Inc. or its affiliates. All other registered and unregistered trademarks and logos are the property of their respective owners. Because we are continuously improving our products and services, Pentair reserves the right to change specifications without prior notice. Pentair is an equal opportunity employer.

CH5816 REV B FE16 © 2016 Pentair Residential Filtration, LLC All Rights Reserved.