



FAIRBANKS NIJHUIS™

**VTSH®-SCR VERTICAL TURBINE
SOLIDS HANDLING SCREW PUMPS
INSTALLATION, OPERATION AND MAINTENANCE MANUAL**

NOTE! To the installer: Please make sure you provide this manual to the owner of the equipment or to the responsible party who maintains the system prior to installation.

PUMP IDENTIFICATION :

Carefully record all of the following data for your pump. This data will aid in obtaining the correct replacement parts for your pump. In addition to the nameplate, the pump serial number is also stamped on the discharge flange.

Pump:

Serial Number: _____

Model Number : _____

Size: _____

GPM: _____

Head (feet): _____

Motor:

Manufacturer: _____

Horsepower: _____

Serial Number: _____

Motor Frame: _____

Full Load Speed: _____

Full Load Amps: _____

ph / Hz / V: _____ / _____ / _____

Date Pump Arrived _____

Date Placed in Service _____

VTSH®-SCR INSTALLATION, OPERATION AND MAINTENANCE

TABLE OF CONTENTS:

INTRODUCTION	2	Operating at Reduced Capacity	20
SAFETY INFORMATION	2	Initial Start-up	20
STORAGE OF PUMPS	3	Normal Operation	21
DESCRIPTIONS AND DEFINITIONS	4	Shutdown	21
INSTALLATION	5	Emergency Procedures	21
General	5	Seasonal Operating Instructions	21
Lifting	5	TROUBLESHOOTING	22
Location and Handling	6	MAINTENANCE	24
Pump Weight Chart	6	Preventive Maintenance	24
Foundation	6	Seal Box	24
Wet Well Inspection	6	Packing Replacement	24
Leveling, Grouting and Piping	7	Corrective Maintenance	25
Hydrocone	7	Time Requirements	25
Pump Assembly	7	Qualifications Required	25
Bowl Assembly Installation	7	Pump Disassembly	25
Shaft Coupling Assembly	8	Column, Shaft and Head	25
Enclosing Tube Assembly	9	Bowl Disassembly	26
Column Assembly	9	Inspection for Replacement	27
Discharge Head (Motor Pedestal) Installation.....	9	Pump Bowl Assembly	27
Mechanical Seal	10	Liners	28
Pump Installation	11	Liner Removal	28
Preparation for Installation	11	Installing New Liners	28
Water Lubrication System	11	REPAIR PARTS	29
DRIVER INSTALLATION	15	Ordering Parts	29
Hollow Shaft Drivers/Right Angle Gears, General	15	Recommended Spare Parts	29
Installation, Hollow Shaft Drivers/Right Angle Gears,		Predicted Life	29
General.....	15	Returning Parts	30
Rotation	15	SERVICE	30
Solid Shaft Drivers, General	16	Warranty Service	30
Installation, Solid Shaft Drivers	16	Service after Warranty	30
OPERATION	19	ASSEMBLY DRAWINGS	31
General	19		

INTRODUCTION:

CONGRATULATIONS! You are the owner of the finest pump commercially available. If you give the proper care as outlined and recommended by this manual, it will provide you with reliable service and long life.

CALIFORNIA PROPOSITION 65 WARNING:**WARNING:**

This product and related accessories contain chemicals known to the State of California to cause cancer, birth defects or other reproductive harm.

IMPORTANT:

Read this complete manual and manuals for all component equipment before assembly or installation is started. It is designed to supply adequate instructions for the installation, operation and maintenance of your pump. Failure or neglect to properly install, operate, or maintain your pump may result in personal injury, property damage, unnecessary damage to the pump, or may void your warranty.

This manual applies to the pump installation, operation and maintenance. Variations exist in both the equipment used with these pumps and in the particular installation of the pump and driver. Therefore, specific operating instructions are not within the scope of this manual. If your operating conditions ever change, always refer to the factory for reapplication. Refer to the manuals provided by manufacturers of the accessory equipment for their separate instructions.

If there are questions regarding the pump or its application that are not covered in this manual, please contact the factory as follows:

Field Service Department
Fairbanks Nijhuis
3501 Fairbanks Avenue
Kansas City, KS 66106
Tel: (913) 371-5000

IMPORTANT SAFETY NOTICE:

Safety should be of the utmost importance when working on or near pumping equipment. Before attempting to operate this equipment, read this manual in its entirety, taking special notice of all CAUTIONS, WARNINGS and/or DANGER notifications. These warnings apply to pumps supplied by Fairbanks Nijhuis. Refer to the manuals supplied by the driver control manufacturer for additional warnings before operating this equipment.

The words DANGER, WARNING and CAUTION have different connotations and are generally defined as follows:

DANGER:

DANGER indicates an imminently hazardous situation which, if not avoided, will result in death or serious injury.

WARNING:

WARNING indicates a potentially hazardous situation which, if not avoided, will result in serious injury.

CAUTION:

CAUTION indicates a potentially hazardous situation which, if not avoided, may result in minor or moderate injury or may indicate that improper practices will result in equipment malfunction or failure. It may also be used to alert against unsafe practices.

IMPORTANT:

Another notation will appear throughout this manual. IMPORTANT indicates the highlight or accent of specific information. The installation, use and operation of this type of equipment is affected by various federal, state and local laws. The

regulations concerning OSHA Compliance with such laws relating to the proper installation and safe operation of this type of equipment is the responsibility of the equipment owner. All necessary steps should be taken by the owner to assure compliance with such laws before operating or maintaining the equipment.

SAFETY NOTES:

These warnings apply to pumps supplied by Fairbanks Nijhuis. Refer to the manuals supplied by the driver or control manufacturers for additional warnings before operating this equipment.

Before attempting to install and operate this pump:

IMPORTANT:

Familiarize yourself with this manual.

DANGER:

Disconnect or lock out the power source to ensure the pump will not start. Check with appropriate electrical test equipment.

DANGER:

Do not attempt to service the pump until the electrical power has been disconnected and it has been verified that the pump cannot start.

WARNING:

Certain procedures in disassembly and assembly require parts be heated to high temperatures. Heat resistant gloves must be worn when handling heated parts. Heated parts can cause severe personal injury.

CAUTION:

After the pump has been installed, make certain that the pump and all piping connections are tight and are properly supported prior to start-up and operation.

DANGER:

Do not operate the pump without the protective guards in place over the rotating parts. Exposed rotating parts can catch clothing, fingers or tools, causing severe injury. Any operation of this machine without a protective guard can result in severe bodily injury. The responsibility for the installation of protective guards is that of the equipment owner.

CAUTION:

This pump is designed for the exclusive use of pumping water. It should not be used for pumping other media unless a specific Purchase/Buyer agreement is negotiated.

WARNING:

Do not attempt to try to clean the pump with bare hands. The pumped material may contain items that may present health hazards such as needles and other sharp objects. Always wear heavy puncture resistant gloves.

WARNING:

Because many installations use automatic starting equipment, the pump unit may start at any time without warning.

STORAGE OF PUMPS:

CAUTION:

If the equipment is not to be immediately installed and operated, THE FOLLOWING INSTRUCTIONS SHOULD BE ADHERED TO AS A MINIMUM.

Consider a unit in storage when:

1. It has been delivered to the job site and is awaiting installation.
2. It has been installed but operation is delayed pending completion of plant construction.
3. There are long (30 days or more) periods between operation cycles.
4. The plant (or facility) is shut down.

NOTE: Improper storage could cause product failure resulting in repairs not covered by warranty.

WARNING:

Refer to driver manufacturer's manual for storage instructions for the motor.

UNASSEMBLED PUMPS:

- A. Store the unassembled components in a clean, dry and well-ventilated place free from vibrations, moisture and temperature variation.
- B. Wipe all exposed machined surfaces clean and coat with a heavy layer of grease or other equivalent rust preventive material.
- C. Cover the suction and discharge of the pump with cardboard or wood to prevent entry of any foreign material. This also applies to column sections.
- D. The enclosing tube, bearings, shaft and couplings should be stored as components, i.e., shaft with couplings installed on lower ends inserted into enclosing tubes with bearings installed in upper ends. The ends should then be wrapped with heavy plastic or protective material and secured tightly to prevent entry of any foreign material.

ASSEMBLED PUMPS:

1. Remove the gland halves and packing from the stuffing box, if the pump is so equipped, and coat inside of packing box with grease. If the pump is equipped with an inside mechanical seal, remove the pipe plug in the stuffing box cover and coat the seal with light oil. This may be done by using an oil can, squirting the seal through the tapped opening while rotating the pump shaft. If equipped with an outside seal, oil and cover for protection.
2. When pumps are stored assembled in horizontal position, it is necessary to rotate the entire pump and column assembly 90 degrees once per month. This practice will help prevent the weight of the shafts from deforming the bearings and shafting.
3. Pumps stored fully assembled and installed are to have the shaft rotated once per week to prevent brinelling of motor thrust bearings. Packing or mechanical seals are to be serviced as noted above.

DESCRIPTIONS AND DEFINITIONS:**GENERAL:**

The VTSH®-SCR pump consists of six major components. These components are the pump bowl assembly, column pipe, enclosing tube, line shafting, discharge head, and the driver.

WATER LUBRICATION SYSTEM:

In a water flush system, the pump bearings and line shaft bearings are isolated from the pumped media. The entire length of the line shaft is encased in an enclosing tube. The lower section of enclosing tube is attached to the diffuser bowl, and the upper section terminates in the surface elbow/pedestal at the tension box. Clean or filtered water is injected at the tension box at a pressure greater than that developed by the pump. The clean water then flows through the enclosing tube to the diffuser bowl bearings, providing lubrication for the entire pump bearing system. Refer to drawings 24LYA1934-147 and 24LYA1934-148 pages 13 and 14 for the seal water flushing set up and requirements.

BOWL ASSEMBLY:

The VTSH® -SCR pump bowl assembly consists of the suction bell, diffuser bowl, bronze backed rubber type bearings, liner, screw type impeller, and pump shaft. The bowl assembly is available only as a single stage unit with water lubrication.

The suction bell and liner serves as the intake for the pump bowl assembly. Liquid is moved by the impeller through the diffuser bowl where it is directed into the pump column pipe.

The diffuser bowl contains two bearings installed in the top and bottom of the bowl hub. Bowl bearings are fluted rubber bonded to a bronze shell and receive lubrication through the enclosing tube.

The impeller is secured to the pump shaft with a socket head capscrew and key.

COLUMN PIPE:

Column pipe for the VTSH®-SCR pump is flanged with bolted connections and registered fits for accurate column alignment. A splitter vane integral within the column prevents fibrous and stringy material from entanglement around

the enclosing tube. Column pipe is available in standard 5' or 10' lengths with a variable length section of column supplied as required to make up the specified overall length.

ENCLOSING TUBE:

The enclosing tube surrounds the shafting and protects both the line shaft and the bearings from the pumped liquid. It provides a channel for lubricating the shaft bearings. The connector bearings for the shafting are threaded on the outside diameter and connect the enclosing tube sections. The bottom section of enclosing tube threads to the diffuser bowl adapter or upper bowl bearing. The enclosing tube assembly is tensioned by a seal box assembly.

LINE SHAFTING:

The line shaft transmits torque from the pump driver to the pump bowl assembly and operates inside the enclosing tube. Both ends are precision machined and threaded. They are secured together with threaded couplings. Line shafting is available in standard 5' or 10' lengths with a variable length section of column supplied as required to make up specified overall length. The shafting is supported by bearings. Bronze connector bearings with longitudinal grooves allow water to flow to the pump bearings. A shaft sleeve is fixed to the top shaft at the packing box location. Clean water for lubrication must be supplied from an external source connected to the packing box.

DISCHARGE HEAD:

Discharge heads perform multiple functions: direct the pump flow from the pump column to the discharge piping system, provide a method for sealing the line shaft, provide a base from which the pump is suspended and provide a mounting surface for the driver.

Surface discharge heads incorporate both the discharge elbow and driver pedestal in one piece. A flanged or plain end discharge connection can be supplied. The bottom surface of the discharge head is machined for a sole plate.

UNDERGROUND ELBOW:

An underground discharge elbow can be provided in which case a separate driver pedestal is included. A flanged or plain end discharge connection can be supplied.

DRIVERS:

A variety of driver sizes and types can be supplied based on the specific job requirements. Drivers may be either vertical hollow or vertical solid shaft motors, or right angle gears coupled to horizontal shaft drivers.

Normally a vertical hollow shaft driver is used. In this configuration, the line shaft passes through the driver, positioned with an adjusting nut to accommodate impeller adjustment and is connected to the top of the driver by a keyed drive hub or coupling.

Solid shaft drivers require special adjustable couplings in order to attach to the pump shaft and to accommodate impeller adjustment. Refer to your submittal package for your specific pump driver configuration.

INSTALLATION:

GENERAL:

Prior to assembly and/or installation, the pump and loose parts are to be inspected for completeness, correctness and cleanliness. During this inspection, all parts are to be thoroughly cleaned and any burrs removed by filing. The pump bowl assembly, including the line shaft coupling, is normally shipped completely assembled. Both the suction and discharge openings should be inspected for damage and foreign materials.

LIFTING:

The use of a crane or hoist of adequate capacity is required throughout the installation process.

DANGER:

The pump, the pump components, and driver are to be lifted using adequate crane and sling capacity. All applicable safe hoisting practices should be employed.

WARNING:

Extreme caution is to be exercised when hoisting components with open lifting lugs. Precautions should be taken to prevent hoisting slings from coming out of the lugs.

Never attempt to mount the driver on the discharge head prior to installation of the pump.

Never attempt to hoist the entire pump by the driver lifting lugs or eyes. These lifting points are designed only to hoist the weight of the driver, not other attached components.

The assembled unit, less the driver, may be lifted with suitable slings through the discharge head (pedestal) windows or by eyebolts. If the head is provided with lifting lugs, these should be used. Refer to Table 1 to calculate total weight.

The driver may be lifted using the proper eyebolts provided by the manufacturer. The pump is to be hoisted by the discharge head (pedestal). Pumps thirty feet or more in overall length should also be supported at the column midpoint to avoid column/shaft distortion and possible pump damage.

LOCATION AND HANDLING:

The discharge piping should be direct and with as few elbows and fittings as possible.

The pump discharge head (pedestal) and driver should be located in an area that will permit periodic inspection and maintenance. Adequate head and access room should be provided.

IMPORTANT:

All shafting has been prestraightened to a tolerance of 0.005" in 10' prior to leaving the factory. Care in handling must be taken to ensure that the shafting is not bent prior to and during installation.

IMPORTANT:

If pump is received as a completely assembled pump and uses a mechanical seal, the mechanical seal is shipped separately for field installation. Refer to the Mechanical Seal section on page 10 for installation instructions.

Table 1: Pump Weight

Pump Size	8"	10"	12"
Bowl Assembly Wt., (lbs.)	510	815	1575
Surface Discharge			
Column Assembly Wt./10 Ft., (lbs.)	320	490	620
Surface Head Assembly Wt., (lbs.)	680	720	750
Complete Pump with 10 ft. column (Surface Discharge)	1510	2025	2945
Below Ground Discharge			
Column and Elbow Assembly	380	550	695
Below Ground Pedestal	560	605	715
Complete Pump with 10 ft. column (below ground discharge)	1450	1970	2985

FOUNDATION:

A foundation must be supplied consisting of any material that will provide a permanent, rigid support. This support is to be of sufficient size and thickness to fully carry the weight of the driver and pump (full of water) and rigid enough to prevent vibration.

Anchor bolts are to be supplied and set in place by the installing contractor. Anchor bolts of appropriate size, length and configuration are required to adequately secure the sole plate to the foundation.

WET WELL INSPECTION:

Prior to installation and start-up, the well must be cleaned of all loose material and debris.

CAUTION:

Reduced performance and possible equipment damage may result from pumping debris.

LEVELING, GROUTING AND PIPING:

If your pump was shipped completely assembled, it is now ready to install.

The pump is furnished with a sole plate which must be leveled in all directions to within 0.005" per foot and grouted before proceeding with the pump installation.

The sole plate (18) is to be lowered onto the anchor bolts and leveled. This can be done by using a good quality machinists spirit level on the machined surface.

IMPORTANT:

Care should be taken to avoid damaging the anchor bolts.

After leveling, the sole plate is to be grouted in place with a good quality nonshrinking grout. After the grout is fully cured, secure the sole plate in place using nuts and washers at each anchor bolt.

IMPORTANT:

Damaging vibration may result if the sole plate is not solidly in contact with the grout bed. Even the highest quality grout may shrink slightly while curing. All leveling wedges, nuts or jackscrews are to be removed or backed off prior to final tightening of the sole plate fasteners. Failure to do so will result in the pump sole plate resting on the leveling devices rather than the grout bed and will void the factory warranty.

HYDROCONE:

Anchor the hydrocone to the wet well floor directly below the center line of the sole plate opening.

PUMP ASSEMBLY:

*If pump is shipped assembled, proceed to the Pump Installation section on page 11.

If the pump has been shipped disassembled, it can be assembled in either a vertical or horizontal position. These instructions describe the pump assembly in the horizontal position, which is standard factory method.

- A. Prior to assembly, all components are to be identified and laid out in the order of assembly. Standard length (5' or 10') intermediate column, enclosing tube and shaft, are interchangeable and can be assembled in any order.

If the pump has a below ground discharge, locate the section of column containing the elbow and determine its position. Refer to the setting plan to determine the distance from the baseplate to the discharge center line. Determine which sections of column tube and shaft are to be assembled above and below the elbow.

NOTE: Connection between bowl assembly and enclosing tube is threaded.

Shorter nonstandard column, enclosing tube and shaft sections, are provided to accomplish the required overall pump length and are normally installed at the top of the pump directly under the discharge head (pedestal). The top enclosing tube has longer threads to engage the top tube packing box (63) and connector bearing (63B).

NOTE: Shaft and enclosing tube assemblies must be of equal length with the exception of the top section.

- B. Refer to Shaft Coupling Installation and assemble a shaft coupling onto each section of shaft. The top drive shaft is the variable length piece and should be arranged so the sleeve is at the top (driver) end.

NOTE: Shafts and column sections must be the same length with the exception of the top section.

Bowl Assembly Installation:

NOTE: Before proceeding, measure and record the pump bowl assembly end play. This information will be needed later.

- A. Position the bowl assembly horizontally. Block the assembly from rolling. Flanged connections should be thoroughly cleaned to remove any rust or debris. Apply a consistent bead of 518 Loctite® or equivalent to the male flange prior to assembly. Care should be taken when assembling the components.

CAUTION:

Careless handling may damage the bowl assembly.

- B. Refer to Shaft Coupling Installation for coupling installation and install a coupling on the pump shaft if a coupling was not shipped installed.

Installation:

- A. With a shaft coupling (31) attached to the pump shaft at the bowl assembly, lift the first shaft section (23) into position to be attached to the pump shaft.
- B. Support the shaft in position at all times.

IMPORTANT:

Support tube, shaft and column at all times to prevent bending of the component parts.

- C. Thread the shaft into the coupling and tighten. See Shaft Coupling Assembly instructions.
- D. Slide the lower enclosing tube (51B) over the shaft and thread onto the adapter (51C) for 8" and 12" pumps. For 10" pumps, thread onto the upper bowl bearing (168).
- E. Install connector bearing (50) into exposed end of lower enclosing tube (51B). See Enclosing Tube Assembly instructions.
- F. On most VTSH®-SCR pumps, the enclosing tube lengths are one-half the length of the shafting. In this case, install a second section of enclosing tube (51) onto the connector bearing from the first section.
- G. Position the first section of column over the enclosing tube and shafting. Align the splitter vane with a vane in the diffuser bowl.

IMPORTANT:

Column must be installed so that the splitter vane is aligned with a vane in the diffuser bowl and splitter vane in adjacent sections of column.

- H. Align the bolt holes and install capscrews and nuts. Tighten properly.
- I. Thread a coupling onto the exposed end of the shafting and attach the next piece of shafting.
- J. Repeat steps above to complete installation of line shaft, enclosing tube and column.

Shaft Coupling Assembly:

Shaft couplings should be installed according to the following procedure:

NOTE: All shaft and coupling threads are left-hand.

- A. Examine and clean all shaft (23) and coupling (31) threads carefully.
- B. Apply a thin coat of anti-seize lubricant to the threads. Wipe off excess lubricant after making up shaft joints
- C. Thread a coupling (31) onto the shaft by hand.
 1. If force is required, look for damaged or dirty threads. Damaged threads may cause misalignment of the coupled shaft.
 2. Butt the ends of the shaft solidly together. The ends of the shaft should be centered in the coupling.
 3. Remove any burrs left on shaft or coupling after tightening shaft joint.

IMPORTANT:

Do not allow metal filings to drop into pump, tube or bearings.

Enclosing Tube Assembly:

IMPORTANT:

All joints must be properly cleaned, deburred and firmly seated. Any misalignment of these joints may cause vibration and/or excessive bearing wear.

- A. Examine and clean all enclosing tube (51, 51A, 51B), connector bearing (50), and adapter (51C) threads carefully.
- B. Coat the enclosing tube threads with Permatex® #2 or equivalent.
- C. Thread a connector bearing (50) into all the tubes, except the top section (51A, with the extra long threads). Half of the bearing should be exposed.
- D. Connect the tubes by threading one section of tube onto the exposed threads of the connector bearing.
- E. If force is required, look for damaged or dirty threads.

Column Assembly:

- A. Examine and clean all column flanges. Remove any coating on the flange faces.
- B. VTSH®-SCR column flanges have register fits. When assembling column, take care to properly seat the male/female fits. Apply a consistent bead of Loctite® 518 prior to assembly.
- C. Align bolt holes and be sure splitter vane in both sections of column are also aligned.
- D. Install capscrews and nuts. Tighten to proper torque for bolt size according to Table 2.
- E. If column is coated, clean bolting and apply proper coating to hardware.

Discharge Head (Motor Pedestal) Installation:

CAUTION:

Do not install seal box prior to assembling the discharge head (motor pedestal) to the column. Damage will occur.

- A. Lightly coat the top column flange face and register with grease and install the column gasket (28A) if furnished.

Surface Discharge:

- B. Position the head (7) so that it is in a horizontal position.

Below Ground Discharge:

- C. Position the pedestal (62) so that it is in a horizontal position and in correct orientation with the discharge elbow.
- D. Move the head (pedestal) to within 1/4" of the flange, taking care not to bump the shaft or tube. Align the splitter in the head with the splitter in the column. Slowly move the head (pedestal) into position against the column flange, being sure the flange register is located inside the head (pedestal). Install and tighten all the flange bolts.

CAUTION:

Do not follow seal box installation instructions while pump is horizontal. Seal box is to be installed only when the pump is in the vertical position.

Shaft Seal Box Installation:

- E. Thoroughly clean all mating and threaded surfaces of the seal box assembly (63). Coat the sealing face of the seal box with Permatex® #2 or equivalent.
- F. Position the copper gasket (63A) on this surface and coat the exposed surface of the gasket with Permatex #2 or equivalent. Next, evenly coat the threaded portion of the seal box bearing (63B) with Permatex #2 or

Table 2 - Coarse Thread (UNC) Torque Values (lb-ft)
PH-1000-51





	Material:	STEEL SAE J429 GR 2	STEEL SAE J429 GR 5	SS 316 F593 COND. CW	SS 304, A193 CL2 GR B8
Thread Size	Bolt Head Identification:				
	FM Code:	0001	0002	0015	0038
	1/4"-20	4	8	5	8
	1/2"-13	30	60	35	58
	5/8"-11	60	120	65	115
	3/4"-10	100	200	120	192

Table 3: Tube Tension Torque Values

Enclosing Tube Size	Installation and Removal Tool	Required Torque Foot-Pounds
1-1/2"	MS1380A	400 ft. lbs.
2"	MS1380A	400 ft. lbs.
2-1/2"	MS1380A	400 ft. lbs.

equivalent.

- G. Slide the seal box assembly over the top shaft (19A) and thread into the top enclosing tube. If equipped with mechanical seal, refer to Mechanical Seal section.

NOTE: The threads are left-hand.

- H. Continue threading the seal box assembly into the top tube until the gasketed flange rests on the head. Use the special tool, supplied, on the seal box and snug down the box until the enclosing tube is in tension. Properly torque to values given in Table 3.
- I. Install packing or mechanical seal according to the following instructions:

Packed Pumps:

- A. Insert washer in the bottom of the box, then insert one ring of packing (15) at a time, making sure each ring is properly seated. Position each ring so that the end joint is rotated 180° from the preceding ring.
- B. Assemble the gland halves (8) and insert into the seal box. Position the gland bolts (8A) and lock washers into the arms of the seal box and into the ears of the gland assembly. Thread on the gland bolt nuts, slightly compressing the packing. Loosen the gland nuts until they can be turned by hand.

NOTE: Packing is designed to be water lubricated by the flush lubrication system.

This lubrication will keep the packing cool and prevent excessive shaft sleeve wear. A steady stream of water, about 1/8" diameter, is required from the seal box.

- C. Slide the water slinger (126) over the shaft and move it down to be just above the packing box gland.

Mechanical Seal:

CAUTION:

Mechanical seal should not be installed until pump is mounted on sole plate.

NOTE: See page 39 for illustration.

These instructions are for an inside single mechanical seal. Since seals supplied by different vendors may vary slightly, these instructions are general in nature. Refer to any specific seal installation instructions that may be supplied with your pump or contact the factory.

- A. Prior to installation inspect the seal, seal housing and sleeve to make sure they are clean and free from burrs, nicks or dirt.
- B. Remove any burrs or nicks and apply a light coat of liquid soap or liquid detergent to the shaft sleeve (13).

IMPORTANT:

Seal faces are lapped and polished to a mirror finish. It is imperative that sealing faces be handled with care and kept perfectly clean. DO NOT touch the sealing faces.

- C. Install the rotating element (456) and retainer (456B) over the sleeve.
- D. Install the stationary seat (456A) into the gland (431).

NOTE: Use a nonpetroleum lubricant on the O-rings and carefully press the seat into the gland.

- E. Install the gland over the sleeve.
- F. Do not bolt the gland to the seal box until impeller adjustment has been accomplished.
- G. Refer to Tables 4 and 5 on page 16 and adjust the impellers.
- H. Raise the gland (431) and locate the retainer (456B) so that it is flush with the top of the seal box face. Tighten the setscrews securely.
- I. Make sure the seal rotating assembly is in position on the retaining ring.
- J. Slowly and squarely lower the gland (431) into position on the seal box and fasten with capscrews.

Seal Removal:

- J. Loosen the gland bolts.
- K. Raise the gland and loosen the setscrews securing the retaining ring to the sleeve.
- L. Use the adjusting nut and lower the impeller until it rests on the bowl seat.
- M. If equipped with a vertical hollow shaft driver, loosen the shaft coupling (31) and remove the driver shaft (19).
- N. If equipped with a vertical solid shaft driver, remove the coupling spacer (if so equipped), the adjusting nut and pump shaft coupling hub.
- O. Remove the seal gland (431).
- P. Remove the seal rotating seat (456) and retainer (456B).
- Q. Inspect all parts of the seal. If any parts show signs of wear, the complete seal should be replaced.

PUMP INSTALLATION:

Preparation for Installation:

Flush the pump liberally with clean water just before installing. All corrosion retardants, dirt and grease should then be removed from flanges, shafts and machined surfaces. All threaded and flanged surfaces should be given special cleaning attention.

- A. Inspect the sole plate mounting surface and bottom surface of discharge head (pedestal) to assure surfaces are clean and level.
- B. With proper lifting device attached and pump properly supported, lift pump into vertical position over opening in sole plate.

Warning:

Do not rotate pump into vertical position resting on the suction bell. This will result in damage to the pump.

- C. Lower into position noting correct discharge position. As unit is lowered, align mounting holes in pump discharge head (pedestal) with threaded holes in sole plate.
- D. Insert capscrews to hold discharge head (pedestal) to sole plate. Torque to proper tightness as show in Table 2 on page 9.
- E. Discharge piping may now be connected to the pump discharge flange. All piping connections must be made with the pipe in a free supported state and without the need to apply vertical or side pressure to obtain alignment of the piping with the pump discharge.
- F. Discharge Pipe Connections:
 - 1. Flange-to-flange connection: The flange-to-flange pipe connection requires a gasket between the flanges. With piping properly supported and attached to pump discharge flange, tighten bolts, taking care not to impose any pipe strain on pump.
 - 2. Dresser Coupling: See manufacturer's recommendations.
 - 3. Victaulic Coupling: See manufacturer's recommendations.
- G. In the event an expansion joint is installed in the piping between the pump and the nearest point of anchor in the piping, a force equal to the area of the expansion joint times the pressure in the pipe will be transmitted to the pump. Pipe couplings that do not provide an axially rigid connection have the same effect. It is recommended that a pipe anchor be installed between the expansion joint and the pump.

Water Lubrication System Installation:

Water lubrication system connections:

An outside source of clean, pressurized water is required. This water is used to lubricate and flush the bearings. An NPT pipe tap is located on the side of the seal box assembly for connection to the water supply. Refer to Water Lubrication System chart 24LYA1934-147 on page 13 for proper flow and pressure requirements.

CAUTION:

Pump requires adequate flush water at all times during operation. It is recommended flush water be on at all times; however, if pump is used infrequently it is mandatory the flush water be started a minimum of 5 minutes prior to starting the pump and 15 minutes following pump shutdown.

- A. Packed Pump: The water lubrication system in addition to providing water to the pump bearings also provides water to the packing for lubrication and cooling.
- B. Mechanical Seals: For standard mechanical seals, the water flush enters the seal housing and provides cooling flush water for both the mechanical seal and the pump bearings. Refer to the Mechanical Seal section on page 10 for proper procedure to install and set the mechanical seal.

NOTE: Some special mechanical seals may require a separate water flush line.

- C. Flow alert module.
 - 1. Refer to the installation instructions packaged with the flow alert module and assembler to the flow meter.
 - 2. Wire the Electronic Module according to the instructions provided.
 - 3. Contact the factory if the installation instructions are missing.

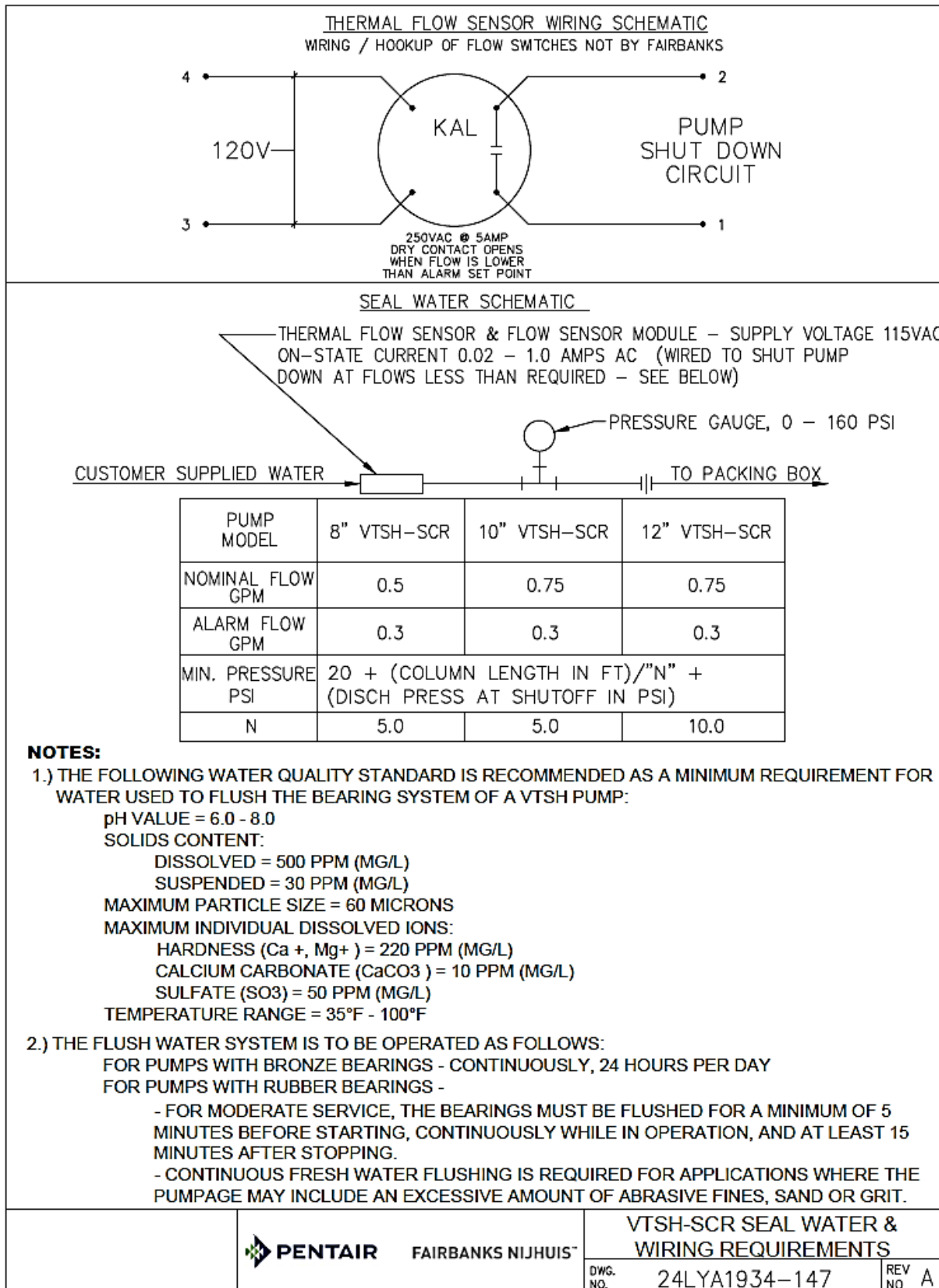

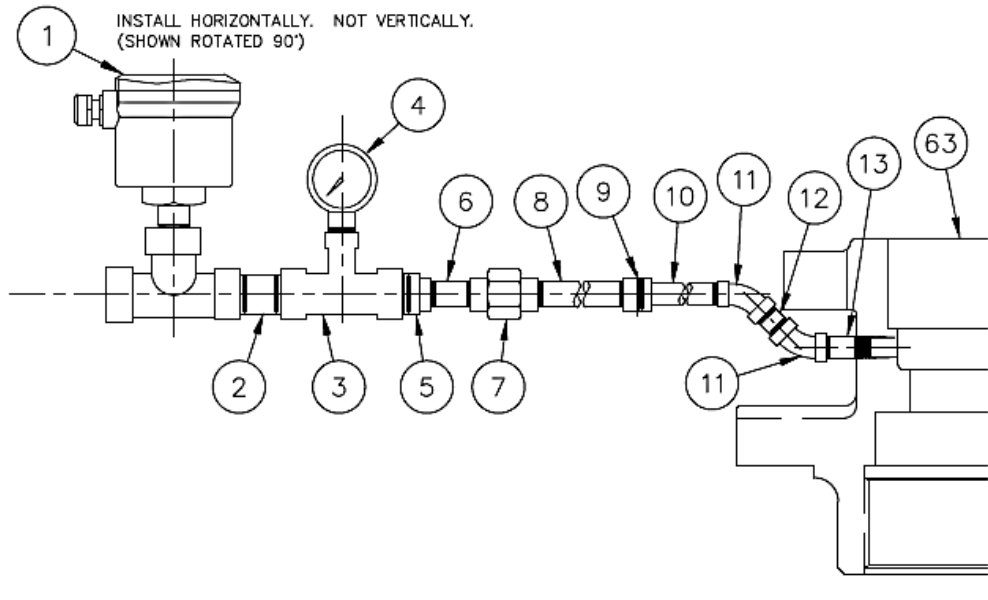

63	1	H7x7037xx-0220-F	VTSH PACKING BOX
13	1	20FM6A0002-7380-F	1/8" PIPE NIPPLE X 1"LG
12	1	20FM6A0006-7380-F	1/8" PIPE NIPPLE X 2"LG
11	2	20FM3B0001-0008-F	1/8" X 45° ELBOW
10	1	20FM6A0012-7380-F	1/8" PIPE NIPPLE X 3-1/2"LG
9	1	20FM2A0001-7380-F	BUSHING 1/4" X 1/8"
8	1	20FM6A0056-7380-F	1/4" PIPE NIPPLE X 3"LG
7	1	20FM8B0001-0008-F	1/4" UNION
6	1	20FM6A0052-7380-F	1/4" PIPE NIPPLE X 2"LG
5	1	20FM2A0005-0008-F	BUSHING 1/2" X 1/4"
4	1	HYD13S-9906-F	160# PSI PRESSURE GAUGE
3	1	20FM9A0014-0008-F	TEE 1/2" X 1/2" X 1/4"
2	1	20FM6A0141-7380-F	1/2" PIPE NIPPLE X 2"LG
1	1	HYD13Vx-9906-F	* FLOWMETER
ITEM	QTY	P/N or MATERIAL CODE	DESCRIPTION

* KOBOLD MODEL KAL-K (KAL-4000 SERIES)
KAL-4215-P03R WITH TEE

REFERENCE SCHEMATIC & REQUIREMENT DWG:
24LYA1934-147

		REV NO	A
		8", 10", & 12" VTSH-SCR SEAL WATER ASSEMBLY	
DWG. NO.		24LYA1934-148	

DRIVER INSTALLATION:

IMPORTANT:

Read and understand the driver manufacturer's manual before proceeding. Determine if the driver to be installed is a vertical hollow shaft electric motor, a solid shaft motor, or a right angle gear. Refer to the appropriate instructions.

CAUTION:

Grease lubricated drivers are typically shipped prelubricated. Oil lubricated drivers and right angle gears are typically shipped dry and require an initial fill of the manufacturer's recommended lubricant prior to start-up. See driver manufacturer's manual for lube specifications. Initial start-up lubricants are not supplied by the manufacturer.

Hollow Shaft Drivers/Right Angle Gears, General:

Hollow shaft drivers provide a hollow tube through the rotor. The pump shaft passes through the tube and attaches at the top of the driver. The VTSH®-SCR pump design uses a shaft coupling above the seal box assembly. This allows the motor to be set in place and the top section of shaft installed later, through the top of the driver.

Register fits on the bottom of the driver base and on the top of the discharge head (pedestal) facilitate driver positioning. The driver is held in position by the mounting bolts. Doweling or pinning of the driver is not required, but may be implemented at the owner's option.

If hollow shaft driver is equipped with optional steady bushing (required for pumps installed with a mechanical seal), see manufacturer's installation procedure.

Installation, Hollow Shaft Drivers/Right Angle Gears, General:

DANGER:

Electrical motors must be installed and operated only by qualified, trained electrical technicians. Consult the motor manufacturer or the motor manual to assure that all installation and operation safety procedures are fully understood and implemented. Always lock out all controls and/or power supplies and verify driver cannot be started before installing or servicing electrical apparatus.

- A. Before installation, remove the driver top cover. Remove the driver clutch coupling (or nonreverse ratchet if so equipped). This will facilitate top shaft installation and rotation check.
- B. Thoroughly clean motor mounting flanges of all rust and debris.
- C. Lift the driver over the mounting surface and carefully lower into position. Lower and position the driver base over the register fit of the mounting surface while maintaining bolt hole alignment and conduit box orientation.
- D. Bolt the driver down, following standard precision alignment procedures to ensure alignment. If an electric motor is used, connect it to the electrical source. If a right angle gear is used, proceed to step E.

Rotation:

Remove or disable the nonreverse ratchets (if so equipped) and "bump" the motor to check rotation. This is generally accomplished on three-phase motors by engaging and immediately disengaging the power switch. It is seldom necessary to engage the power source for more than one second to determine motor rotation.

Note the direction of motor rotation. If the motor rotates counterclockwise as viewed from the top, the rotation is correct and installation may proceed. If the motor rotates clockwise as viewed from the top, reverse any two of the three power leads and motor rotation will be reversed.

CAUTION:

Line shaft threads are left-hand.

Operation of the pump in a clockwise (as viewed from the top) direction will cause the line shaft couplings to unthread, causing serious damage to the pump.

Assure that no burrs or foreign matter exists on the shaft threads.

- E. Install the driver shaft through the top of the driver and tighten into the line shaft coupling. Make sure that the top shaft is centered in the tube.
- F. Install the driver coupling and/or nonreverse ratchet. Install the gib key (5A) (supplied with the driver) into the driver/shaft keyway. The key should be a close slip fit in the keyways. It may be necessary to deburr or file the key to achieve the proper fit. Never drive or wedge the key into an overly tight keyway.
- G. Install the top shaft adjusting nut (5). The adjusting nut is used to lift the shaft/impeller assembly to achieve proper impeller clearance. Adjusting nut threads are right-hand.

NOTE: Before installation of the nut, the weight of the shaft/impeller assembly rests on the suction bell liner seat. This condition makes the shaft almost impossible to rotate until the nut is installed and the shaft/impeller is raised off the bell seat. In running position, the shaft, impeller and hydraulic down thrust are supported by the driver thrust bearing.

- H. Tighten the nut on the shaft until the impeller is raised slightly off the bowl seat. This will be evident when resistance to shaft rotation disappears as the impeller is lifted off the seat.
- I. With the impeller slightly off the seat, add the additional nut turns required to achieve the specified clearance. Determine the correct impeller setting from Table 4. The liner should be replaced when further adjustment fails to restore design capacity.

Table 4: Impeller Pull Up

Size	Clearance
8	0.060
10	0.060
12	0.060

Table 5: Impeller Adjustment

Thread Size	Threads Per Inch	Number of Turns									
		1	2	3	4	5	6	7	8	9	10
1"	14	0.07	0.14	0.21	0.28	0.36	0.43	0.50	0.57	0.63	0.70
1-1/4"	10	0.10	0.20	0.30	0.40	0.50	0.60	0.70	0.80	0.90	1.00
1-11/16"	10	0.10	0.20	0.30	0.40	0.50	0.60	0.70	0.80	0.90	1.00

- J. After impeller adjustment, place the adjusting nut lock screw (5B) through the nut and thread into the driver clutch coupling and secure. If the nut must be rotated to align with the clutch coupling hole, always move to the next higher adjustment position.
- K. Replace the driver cover.
- L. Refer to the driver manual to assure that all lubrication instructions have been followed completely.
- M. Consult the driver manufacturer's manual to assure that all safety procedures are completely understood and implemented prior to operation.
- N. If pump has mechanical seal, it may be secured in operating position at this time.
- O. Install protective guards.
- P. Energize winding heaters if applicable.

Solid Shaft Drivers, General:

Solid shaft drivers have a shaft projecting from the bottom of the driver base. The shaft projection has a vertical keyway to transmit torque and an annular groove to suspend the pump shaft impeller assembly. Solid shaft drivers require the use of rigid adjustable couplings to facilitate pump impeller adjustment.

Register fits on the bottom of the driver base and on the top of the discharge head (pedestal) facilitate approximate driver positioning. These fits accommodate the additional movement required for precision alignment. After precision alignment is achieved, the driver is held in position by the mounting bolts. Doweling or pinning of the driver is not required, but may be implemented at the owner's option.

Installation, Solid Shaft Drivers:

CAUTION:

Before installing the driver, read and understand the driver manufacturer's instruction manual.

Electric motors must be installed and operated only by qualified, trained electrical technicians. Consult the motor manufacturer or the motor manual to assure that all installation and operation safety procedures are fully understood and implemented. Always lock out all controls and/or power supplies before installing or servicing.

- A. Check both driver and pump shafts for burrs or dirt, cleaning as necessary. Also check the coupling parts for burrs and dirt, cleaning as required. If force is required to position the couplings on the shafts, nonmetallic hammers should be used to prevent damage to the machined surfaces.
- B. Install the coupling hubs on the driver shaft and top shaft prior to installing the driver according to the following procedure:

NOTE: It is generally most convenient to install the driver coupling hub on the driver shaft before hoisting the driver into position.

- C. Insert the square key into the driver shaft keyway and slide the driver coupling hub onto the driver shaft until the circular key seat is exposed. Install the thrust rings. When a spacer is used, pilot the spacer into the driver hub and secure with the short bolts (see drawing 7000A091 on page 18).
- D. Install a dowel pin into the hole provided in the pump coupling hub. Drive the pin through the coupling hub until it protrudes slightly into the coupling keyway. The purpose of this pin is to prevent the key from falling out of the hub until the setscrew has been secured. Slide pump coupling half hub over top shaft threads.
- E. Align the keyway in the shaft with the keyway in the coupling hub and insert the key.
- F. Thread the coupling adjusting nut onto the top line shaft.

DANGER:

Make sure the main power source is locked off before any electrical connections are made and verify driver cannot be started. After the start has been performed, again lock off the main power source to guard against accidental starting and electrical shock.

- G. Thoroughly clean motor mounting flanges of all rust and debris.
- H. Using an appropriate hoisting system, lift the driver over the mounting surface and carefully lower into position. Engage the driver base over the register fit of the mounting surface. Temporarily bolt the driver down. Follow standard precision alignment procedures to properly align the motor to the pump.
- I. If an electric motor is used, connect it to the electric source per manufacturer's instructions and correct rotation (see rotation section). If a right angle gear is used, proceed to step I.

DANGER:

Make sure all loose coupling parts are off the motor half coupling, and that no part of one coupling half will contact the other half during the bump start, otherwise personal injury or damage to the equipment could occur.

Make sure the protective guard is in place on the discharge head before the bump start is done. Do not operate this machine, even to check rotation, without protective guards in place.

CAUTION:

Oil lubricated drivers are typically shipped dry and require an initial fill of the manufacturer's recommended lubricant prior to bump start.

- J. With nonreverse ratchets (if so equipped) removed or disabled, bump the motor for rotation. Bump start is generally accomplished on three-phase motors by engaging and immediately disengaging the power switch. It is seldom necessary to engage the power source for more than one second to determine motor rotation.

WARNING:

When bumping motors to check for rotation, use extreme care as exposed rotating parts can catch clothing, fingers or tools, causing severe injury or death.

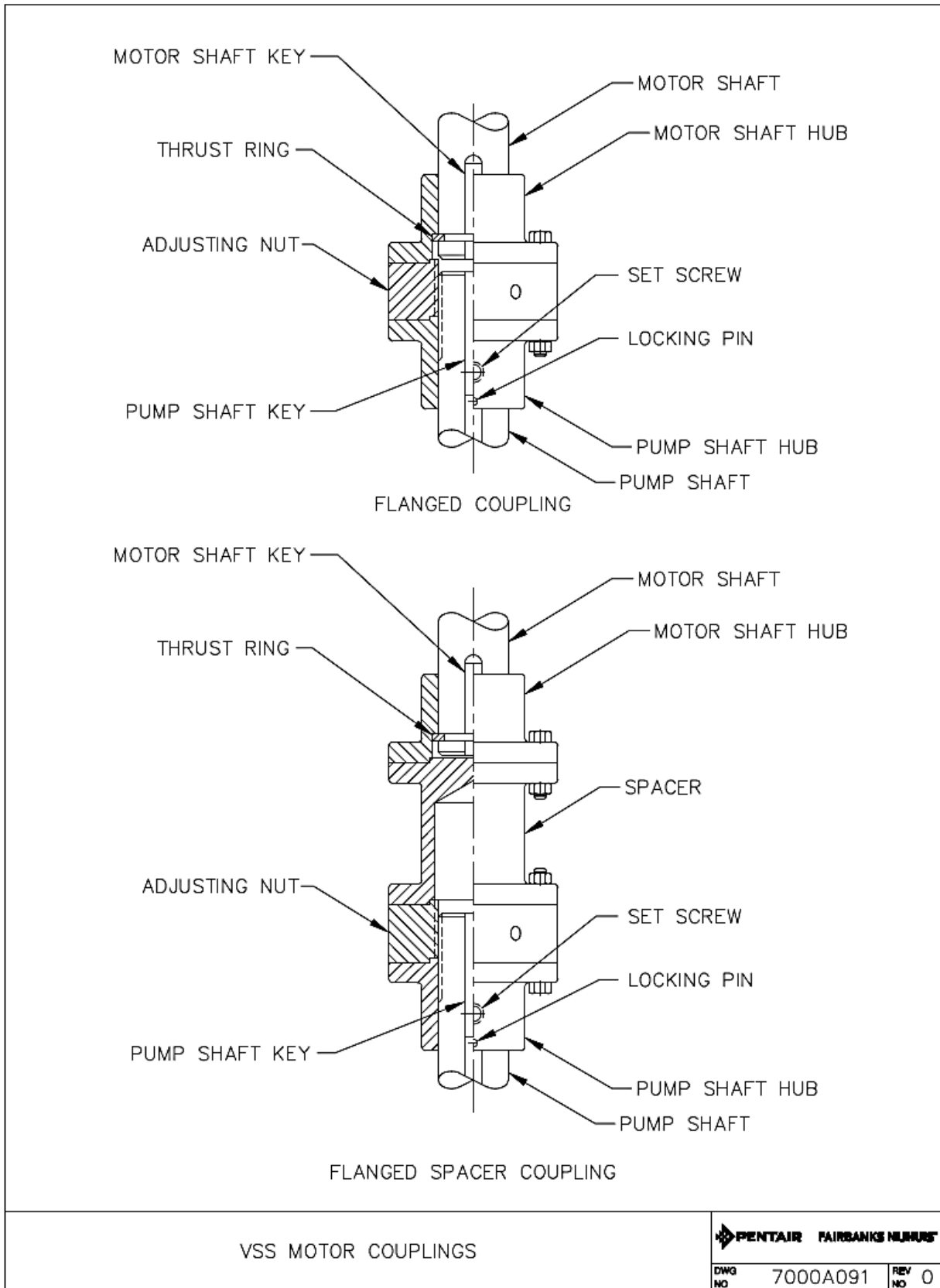

Note the direction of motor rotation. If the motor rotates counterclockwise as viewed from the top, the rotation is correct and installation may proceed. If the motor rotates clockwise as viewed from the top, reverse any two of the three power leads and motor rotation will be reversed.

CAUTION:

Operation of the pump in a clockwise (as viewed from the top) direction will cause the line shaft couplings to unthread, causing serious damage to the pump.

- K. Impeller adjustment is required to achieve the preferred running position of the impeller within the pump bowl and to prevent the impeller from rubbing.
- L. Determine the correct impeller position from Table 4 on page 16.
- M. Thread the adjusting nut upward toward the driver half coupling until the correct amount of gap is reached.
- N. Adjust to the position that bolt holes line up and insert coupling bolts. Torque to the values as shown in Table 6. Install the setscrew in the pump coupling hub and secure.
- O. If pump has mechanical seal, it may be secured in operating position at this time.
- P. Install protective guards.

Table 6: Coupling Bolt Torque

Coupling Size	Torque (Ft. Lbs.)
1125	13
1625	26
2125	115

WARNING:

Make sure the protective guard is in place on the discharge head (pedestal) before operating the pump.

Refer to the driver manual to assure that all lubrication instructions have been followed completely.

Consult the driver manufacturer's manual to assure that all safety procedures are completely understood and implemented prior to operation.

CAUTION:

Grease lubricated drivers are shipped prelubricated. Oil lubricated drivers and right angle gears are typically shipped dry and require an initial fill of the manufacturer's recommended lubricant prior to start-up. See driver manufacturer's manual for lube specifications. Initial start-up lubricants are not supplied by the manufacturer.

OPERATION:

General:

The pump is used to move liquid from one elevation to another. This is accomplished by centrifugal force. Energy supplied to the motor turns the pump impeller at a specified speed. As the impeller rotates, it imparts energy to the fluid as it is discharged from all points around the impeller circumference. The bowl encases the impeller and directs the flow while it converts the liquid velocity from the impeller to the pressure energy, which moves the liquid to the required level.

Because variations may exist in both the equipment used with these pumps, and in the particular installation of the pump and driver, specific operating instructions are not within the scope of this manual. However, there are general rules and practices that apply to all pump installations and operation.

CAUTION:

Before starting or operating the pump, read this entire manual, especially the following instructions:

Before starting the pump:

- ✓ Rotate the shaft by hand to assure all moving parts are free.
- ✓ Install packing.
- ✓ Install water lubrication line to seal box and turn on water. Check pressure and flow.
- ✓ If pump has a seal box with packing, adjust the packing gland finger-tight. Refer to Packing Adjustment in the Maintenance section to properly adjust packing.
- ✓ Install protective guards around all exposed rotating parts.
- ✓ Observe all DANGER, WARNING and CAUTION tags attached to this equipment.
- ✓ Ensure water in sump is at the specified level for adequate submergence.

If excessive vibration or noise occurs during operation, shut the pump down and review the Troubleshooting section on page 22. If the problem cannot be corrected, consult a Fairbanks Nijhuis representative.

Operating at Reduced Capacity:

In a typical application covering a wide range of flow rates, a variable speed driver is often used to adjust pump capacity, and this is taken into consideration by Fairbanks Nijhuis when selecting the pump and impeller trim. Although these pumps are applicable over a wide range of operating conditions, care should be exercised when doing so, especially when the actual conditions differ from the sold conditions. You should always contact your nearest Fairbanks Nijhuis distributor or factory before operating the pumps at any condition other than that for which they were sold.

Table 7: Pump Capacities

Pump Size	Capacity
8"	50%
10"	40%
12"	40%

Generally, these pumps can be operated continuously at a capacity shown in Table 7 of the full pump capacity at the and at higher capacities. At capacities less than shown in Table 7 of the full capacity, the pumps may show accelerated wear and exhibit higher vibration levels. Pumps should not be run at lower capacities than shown in Table 7. Pump CANNOT be run at shutoff.

Initial Start-up:

Inspect the complete installation to ensure that the installation instructions of this manual, and the manuals of all the related equipment, have been followed and that the installation is complete. Use the Prestart-up and Start-up Check List found at the end of this document.

Ensure that the driver is properly serviced and that the proper pump rotation is obtained. Rotate the pump shaft by hand. It should rotate freely on all motor driven installations.

Start the pump according to the following procedure:

- A. Install protective guards around all exposed rotating parts.
- B. Start water lubrication system. Refer to drawing 24LYA1934-148 on page 14 for assembling the system. Refer to drawing 24LYA1934-147 on page 13 for flush water requirements.
- C. Start the driver according to the driver manufacturer's instructions.
- D. Immediately after the pump has been started, check water lubrication system, seal box lubrication and operation, and pump noise level. Continue to monitor these for the first several hours of operation.
- E. Check the driver and other necessary equipment for satisfactory operation following their manuals.
- F. Check the foundation for integrity.
- G. After the first shutdown, repeat the impeller adjustment. Running may have tightened up some of the shaft joints, changing the original setting.

IMPORTANT:

If pump is equipped with mechanical seal, seal gland should be loosened before impeller adjustment is made and then reset seal. Refer to Seal Installation on page 10.

Normal Operation:

Monitor the following during running cycles:

- A. Unit vibration or noise.
- B. Driver lubrication levels and flow.
- C. Seal box leakage.
- D. Water lubrication system.

Check the following before normal start-up:

- A. Driver lubrication levels and flow.
- B. General condition of all equipment.
- C. Water lubrication system.

Shutdown:

Pump stations are usually designed to have the pumps started and stopped automatically. Since this is a function of station design, the operators should be familiar with the system operating parameters. The general procedure to shut down the pump is as follows:

- A. Slowly close discharge valve.
- B. Disconnect the electrical power source.

Emergency Procedures:

Many installations are equipped with emergency shutoff switches near the pump location. These locations should be plainly marked and readily accessible at all times.

The control panel (if used) may be equipped with an emergency start/stop button or switch.

IMPORTANT:

The operator, or persons working around the equipment, should be familiar with locations of emergency start-up and shutoff points.

Shutdown: Shut off the power at the nearest switch.

Seasonal Operating Instructions:

If the pump is located in an area that is subject to freezing temperatures and will not be operated enough to prevent freezing, it should be drained to prevent damage to the casing caused by freezing. Steps should be taken to prevent seal water lubrication system from freezing. Storage instructions must be adhered to.

TROUBLESHOOTING:

If you have followed the installation and start-up procedures outlined in this manual, your pump will provide reliable service and long life. However, if operating problems occur, significant time and expense can be saved if you use the following checklist to eliminate the most common causes of those problems.

Insufficient Pressure or Flow

Cause	Remedy
1. Wrong direction of rotation.	Reverse any two motor lead connections. Check driver O & M.
2. System head too high, resulting in low flow.	Change system. Raise wet well level. Check speed.
3. Impeller running clearance too great.	Reset impeller clearance per O & M manual.
4. Insufficient suction bell submergence.	Raise wet well level.
5. Speed too low.	Check driver speed and voltage.
6. Bowl passage partially plugged.	Clean bowl passages.
7. Impeller passage partially blocked.	Clean impeller passages.
8. Clogged suction bell or sump.	Clean suction bell or sump.
9. Low water level.	Raise wet well level.
10. Air in liquid.	Deaerate liquid. Increase submergence to prevent vortexing.
11. Improper sump design.	Change sump design. Increase submergence to prevent vortexing.
12. Impeller damaged.	Check and repair or replace impeller.

Loss of Suction Operation

Cause	Remedy
1. Low water level.	Raise wet well level.
2. Insufficient suction bell submergence.	Raise wet well level.
3. Wrong direction of rotation.	Reverse any two motor lead connections. Check driver O & M.
4. Air or gases in liquid.	Deaerate liquid. Increase submergence to prevent vortexing.
5. Air lock.	Install air release valve.

Excessive Power Consumption

Cause	Remedy
1. Improper impeller adjustment causing rubbing.	Readjust impeller clearance setting as outlined in this manual.
2. System head lower than rating, pumps operating over capacity.	Change system. Reduce pump speed. Readjust impeller clearance setting as outline in this manual.
3. Speed too high.	Check driver speed and voltage.
4. Improper voltage to driver.	Check driver speed and voltage. Change power source or driver.
5. Misalignment.	Realign driver and pump.
6. Packing box gland too tight.	Readjust packing gland.
7. Shaft bent.	Replace shaft.
8. Specific gravity or viscosity of liquid pumped is too high.	Reduce pump capacity.
9. Pump running below rated capacity.	Check driver speed and voltage.

Vibration or Noise

Cause	Remedy
1. Foundation bolts loose or defect in grouting.	Tighten foundation bolts and/or regrout.
2. Worn pump bearings.	Replace pump bearings.
3. Pipe strain – improperly supported or aligned.	Improperly supported or aligned. Check pipe supports and adjust or realign.
4. System head lower than rating, pumps too much liquid.	Increase system head. Reduce pump speed. Readjust impeller clearance settings as outlined in this manual.
5. Misalignment between driver and pump.	Realign driver and pump.
6. Shaft bent.	Replace shaft.
7. Pump running at shut-off condition.	Open discharge valve. Check for obstructions.
8. Insufficient suction bell submergence.	Increase submergence.
9. Low water level.	Increase wet well level.
10. Air in liquid	Increase submergence to prevent vortexing.
11. Impeller passages plugged.	Clean impeller passages.
12. Foreign object in pump.	Remove foreign object. Check for damage.
13. Bad driver bearing.	Replace driver bearing.
14. Improper sump design.	Change sump design. Increase submergence to prevent vortexing.
15. Solid Build-up.	Clean sump.

Pumped Liquid in Enclosing Tube

Cause	Remedy
1. Insufficient pressure and flow from water lubrication system.	Check water lubrication system and setting and readjust water flow to correct pressure and flow.
2. Worn pump bearings.	Replace bearings.
3. Defective enclosing tube or connector bearing thread	Replace enclosing tube and/or connector bearing thread.

Excessive Packing Box Leakage

Cause	Remedy
1. Gland not properly tightened.	Adjust packing gland.
2. Worn packing or sleeve.	Replace packing and/or sleeve.
3. Ends of packing not staggered.	Repack to stagger packing ends.
4. Water lubrication system pressure too high.	Adjust flush water to correct flow and pressure.

Over-Heating

Cause	Remedy
1. Packing gland too tight.	Adjust packing gland.
2. Water lubrication system line plugged.	Clean water lubrication system line.
3. Shaft bent.	Replace shaft.

MAINTENANCE:**Preventive Maintenance:****WARNING:**

Pumping media may contain hazardous material. Prior to performing maintenance, clean and disinfect pump thoroughly and wear protective clothing, gloves, eye protection and respirator as needed.

To assure satisfactory operation of the pump, scheduled inspection and periodic maintenance are required. We highly recommend an inspection and maintenance log be kept and the inspector immediately report any problems.

This Fairbanks Nijhuis model VTSH®-SCR pump is supplied with water lubricated line shaft and bowl bearings.

A guide for preventive maintenance for normal applications is given below. Unusual applications with abnormal heat, moisture, dust etc. may require more frequent inspection and service.

Table 8: Action Codes

Item	Action Required
Seal box	a
Pump alignment	b
Vibration	b
Lube System	c
Driver Bearings	d
Mechanical Seal	e

Action Code:

- a) Check for proper operation and excess leakage every 150 hours of operation. Adjust packing gland or replace packing as required.
- b) Check for changes on an annual basis.
- c) Check water lubrication system for proper operation on a daily basis.
- d) Follow driver manufacturer's instructions for driver bearing lubrication.
- e) Check for proper operation every 150 hours of operation.

Seal Box:

All packing is subject to wear and should be regularly inspected. Packed box pumps should be checked approximately every 150 hours of operation and the glands should be readjusted if necessary.

CAUTION:

Excessive tightening of the glands may cause shaft sleeve damage.

Packing Replacement:

For general service application with pump temperature 32° F – 200° F (0° C – 93° C), use a good grade of soft, square, long fiber packing thoroughly lubricated and graphited.

For best results, use only Fairbanks Nijhuis replacement packing. Estimated time to replace packing is 1 – 2 man-hours. The replacement procedure should be as follows:

- A. Stop the pump.

DANGER:

Lock out electrical power to prevent accidental starting, which may result in personal injury.

- B. Turn off water lubrication system.
- C. Unbolt and remove the gland.
- D. Use a flexible packing tool* with a hook attachment for removal of the packing.

*The packing tool can be purchased from the factory or local contractor supply house.

- E. Clean the seal box and shaft sleeve.
- F. Inspect the shaft sleeve for wear or rough finish and install a Fairbanks Nijhuis replacement sleeve if needed.
- G. Install the new packing.

Table 9: Packing Box Dimensions	VTSH-SCR Pump Size		
	8"	10"	12"
Stuffing Box O.D. Sleeve	1-3/16	1-3/8	1-7/8
I.D. Box, inches	1-15/16	2-1/8	2-11/16
Box Depth, inches	1.62	1.62	1.62
Packing Size, inches	3/8	3/8	3/8
Rings of Packing per Box	3	3	3

IMPORTANT:

Stagger the packing end joints 180° and firmly seat each ring of packing as you install it. Refer to Table 9 on page 24 for seal box and packing dimensions.

- H. Reinstall the gland and tighten the gland nuts finger-tight. Start water lubrication system. After the pump has been started, adjust the glands so that there is a steady stream, approximately 1/8" diameter, from the seal box. Refer to drawing 24LYA1934-147 on page 13 for water lubrication requirements.

Corrective Maintenance:

WARNING:

Read this entire disassembly procedure and refer to the sectional drawings in this manual before starting.

Major maintenance beyond lubrication and replacement or adjustment of the packing will require disassembly of the pump.

Time Requirements:

Estimated time to disassemble or reassemble the complete pump is approximately 6 – 8 man-hours. Pumps with an overall length greater than 25' require an additional 1 – 2 man-hours per additional 10' section of column and shaft.

Qualifications Required:

The pump described by this manual is designed to be maintained by a mechanic experienced with similar equipment, using normal mechanics tools.

Pump Disassembly:

The following are step-by-step instructions:

The use of a crane or hoist of adequate capacity is required throughout the disassembly process.

DANGER:

The pump assembly, driver and base are to be lifted separately using adequate crane and sling capacity. All applicable safe hoisting practices should be employed.

Column, Shaft and Head:

- A. Stop the pump and lock out the power to the driver. Shut water lubrication system off. Close the discharge valve and water lubrication valve. Disconnect the electrical cables from the driver. Disconnect and remove gauges and all other auxiliary piping.

DANGER:

Check with proper electrical testing equipment to be certain all electrical power to the driver and accessories associated with the pump is disconnected.

- B. **For Vertical Hollow Shaft Motors:** Remove the driver cover, adjusting nut lock screw, and gib key and lower the shaft until the impellers rest on the liner seat. Remove the adjusting nut and driver coupling.
For Vertical Solid Shaft Motors: Remove the bolts holding the coupling halves together slowly so that the impeller does not drop.
- C. Disconnect the shaft coupling under the driver (if used) and remove the top shaft. Remove the capscrews holding driver to discharge head (pedestal).
- D. Lift the driver from the head and set aside.
- E. Remove and disassemble the pump head, the column, shaft seal box, enclosing tube and shafting according to the following procedure, which is essentially the reverse of the installation procedure.
 - 1. Loosen and remove all discharge piping flange bolts. If equipped with Dresser or Victaulic type connections, disconnect and remove per manufacturer's instructions.
 - 2. Loosen and remove bolting from pump head to sole plate.

3. Properly attach lifting device to pump discharge head (if surface discharge) or to driver pedestal (if underground discharge).
4. Lift unit off sole plate and remove from sump. Lower unit to a horizontal position properly supported, with adequate work area to disassemble the pump.

WARNING:

Do not rotate pump into vertical position resting on the suction bell. This will result in damage to the pump.

NOTE: When removing component parts from the pump assembly, clean and inspect the parts to determine if repair or replacement is required. Identify and mark all parts for easier reassembly.

5. Using the tool provided, loosen and remove the shaft seal box by turning clockwise. The shaft seal box bearing (63B) is threaded into the seal box and secured with Loctite®. It may require heating the bearing to 350° F – 400°F to break the Loctite® bond.

WARNING:

To prevent serious personal injury always wear heat-resistant gloves when handling heated parts.

6. Remove the bolts holding the column to the discharge head. Remove the discharge head (pedestal) and set aside.

NOTE: Support the tube and shaft assembly during the disassembly process to avoid bending the shaft.

7. Loosen and remove the bolts holding the top section of column. Remove the top section of column.
8. Remove the shaft and enclosing tube sections according to the following procedure. Store removed sections in a place where they will be protected from damage.
 - a. Loosen the tube connection at the first joint and remove. Note: threads are left-hand.
 - b. Loosen the next section of enclosing tube and remove.
 - c. Loosen the shaft coupling and remove the shaft. Shaft coupling may require cutting for removal.
9. Repeat steps 7 and 8 until all sections of column enclosing tube and shaft have been removed.
10. Remove couplings from shafts and inspect for wear or damage.
11. Remove connector bearings (50) from enclosing tubes and inspect for wear or damage.
12. Inspect the shafting for wear and straightness. Repair or replace as necessary.
13. Inspect the shaft sleeve at the seal box area. If worn or damaged it is to be replaced. It is held in place by Loctite. It may require heating to 350° F – 400° F to break the Loctite bond.

NOTE: Measure and record the position of the shaft sleeve on the top shaft. If removed they are to be reinstalled in the same location.

14. Refer to Bowl Disassembly for procedure to disassemble and inspect the bowl assembly.

Bowl Disassembly:

For disassembly of the bowl, proceed in accordance with steps listed below. Select a clean area for work. Refer to assembly drawing and parts list for part identification.

- A. Place the bowl assembly in a horizontal position, blocked to prevent rolling.
- B. Measure and record the axial end play of the shaft (4).
- C. Place the bowl assembly in an upright position, resting on the suction bell (33) and restrained from falling over.
- D. Remove the shaft coupling (31).
- E. Remove the suction bell flange capscrews.
- F. Lift the diffuser bowl, leaving the pump shaft (4) and impeller (1) at rest on liner seat. Place the diffuser bowl in a horizontal position, blocked to prevent rolling.
- G. Remove the shaft and impeller subassembly from the suction bell.

- H. Remove the impeller capscrew (9). It will be necessary to heat the capscrew to 350° F – 400° F
- I. Remove the pump shaft (4) and key (102) from the impeller (1), being careful not to bend the shaft and not to damage the threads at the coupling end.

NOTE: The impeller hub bore has a taper fit with the shaft. Use a hub puller and apply heat to the impeller hub to expand the bore for easier removal. Use heat-resistant gloves to handle heated parts.

CAUTION:

Care should be taken not to damage the impeller when using a puller or similar device.

WARNING:

Care should be used in removing the impeller. Because of the taper fit, the impeller can come loose suddenly and will be completely loose.

- J. Remove the snap ring (27) from the lower end of the bowl. Then remove the free floating restrictor bushing (163B). Inspect shaft, restrictor bushing I.D and O.D, and bearing I.D. Calculate clearances and check with Table 10 for condition. If the bearings must be removed, use a long shank grinder bit to split the bearings along their full length.
- K. Remove the connector bearing (51C) only if it is to be replaced (Not applicable on the 10" VTSH®-SCR).

Table 10: Nominal Diametrical Bowl Bearing/Restrictor Clearance, Inches

Pump Size	Rubber Bearings	Restrictor
8	0.010	0.005
10	0.010	0.005
12	0.010	0.005

Inspection for Replacement:

After the components are disassembled, each part should be thoroughly cleaned and inspected for wear and physical damage. During cleaning, do not allow any petroleum-based solvents on the rubber bearings.

It is not necessary to remove bearings unless inspection indicates replacement is necessary. If it is necessary to remove bearings, they should be pressed from their seats and discarded.

IMPORTANT:

Use care not to damage bores or hubs during bearing removal.

Any parts showing signs of excessive wear or damage should be replaced with genuine Fairbanks Nijhuis parts.

- A. Inspect the shafting (23) at each bearing location for damage or excessive wear and replace shaft if not salvageable.
- B. Inspect all line shaft bearings (50) and packing box bushing (63B) bores for damage and wear. If the diametric bearing clearance exceeds the limits shown, the bearings must be replaced.
- C. Inspect all bowl bearings (163, 168) for wear and excessive clearance. If the diametric bearing clearance exceeds the limits shown, the bearings must be replaced.
- D. Inspect the bowl liner (98) for excessive wear. The liner should be replaced with a Fairbanks Nijhuis replacement part, available from the parts supplier shown in the repair section of this manual or directly from the factory.
- E. Inspect the top shaft sleeve for wear. Replace as necessary. If the sleeve (13) shows wear or damage, remove the sleeve by heating it to 350° F – 400° F to break the Loctite® bond.
- F. Inspect the mechanical seal (if supplied) for wear and damage.

NOTE: If it is found that any of the bearings or sleeves have excessive wear, it is recommended that all bearings and sleeves be replaced (including bowl bearings).

NOTE: Measure and record the position of the sleeve (13) on the shaft (19A) before removal.

Pump Bowl Assembly:

Clean all components before starting the assembly. Do not apply any petroleum-based compounds to the rubber bearings. The use of a crane or hoist of adequate capacity is required throughout the assembly process.

DANGER:

The pump, the pump components, and driver are to be lifted using adequate crane and sling capacity. All applicable hoisting practices should be employed.

- A. If the suction bell liner is being replaced, refer to the Liner section on this page for complete instructions on removal and replacement of liners.
- B. Place the bowl (30) in horizontal position and block from rolling. Clean the bowl bearing bores, bearings, and bowl mating flanges of all rust and debris.
- C. Apply Loctite® 609 to the outside of the lower bearing (163) and install. Install the restrictor (163B) and snap ring (27).
- D. Apply Loctite® 609 to the outside of the upper bearing (168) and install. Install the connector bearing (51C) or the upper bowl bearing (168) (10 VTSH®-SCR only).
- E. Clean the threads on the impeller fastener (9) and the mating threads in the shaft (4) of all contaminants and oil.
- F. Install the pump shaft (4) with its key (102) into the impeller hub. Apply six drops of Loctite® 609 on the capscrew threads and torque to the required value: See Table 6 on page 19 for the correct torque value.
- G. Place the suction bell (33) and liner (98) assembly in an upright position. Clean the suction bell surface of all rust and debris.
- H. Place the impeller and shaft assembly into the suction bell (33) with the impeller (1) resting inside the suction bell liner (98).
- I. Apply a consistent bead of Loctite® 518 on the suction bell flange. Carefully guide the diffuser bowl down over the pump shaft (4) until it registers on the suction bell flange.
- J. Install the suction bell flange capscrews and tighten them securely.
- K. Apply an anti-seize lubricant to the shaft and coupling threads. Thread the shaft coupling (31) onto the pump shaft (4) until half of the coupling is engaged.
- L. Measure the axial play of the shaft. If it differs unexpectedly from the amount measured prior to disassembly, make sure that all parts are correctly installed and positively seated in their respective positions.
- M. When completely assembled, leave the bowl assembly in an upright position, resting on the suction bell, restrained from falling over, until it is to be reinstalled.
- Q. Apply Loctite® 609 to the top shaft sleeve (13) and top shaft (19A), and install the sleeve in its original location.
- R. Refer to Pump Assembly in the Installation section of this manual and complete pump installation.

Liners:

The pump is equipped with an suction bell liner. If a replacement is required, refer to Liner Removal below.

Liner Removal:

- A. Place the suction bell (33) and liner (98) assembly vertically on a solid surface.
- B. Loosen the connection by pulling liner up from bottom of lower seat in the suction bell.
- C. Finish removing the liner by lifting from the bottom face of the top seat edge.
- D. Remove the anti-rotation pin from the suction bell, only if replacement is necessary.

IMPORTANT:

Care should be used to avoid damage to the liner seat on the diffuser bowl and suction bell.

Installing New Liners:**IMPORTANT:**

To ensure a proper fit, thoroughly clean all mating parts with solvent to remove all grease, oil, dirt, etc.

If the liner is to be replaced, it should be replaced with Fairbanks Nijhuis liner. Install the liner as follows:

- A. Place suction bell (33) in an upright position on a flat surface.

- B. Press the anti-rotation pin into the suction bell.
- C. Lower the suction bell liner (98) into its machined seat aligning the anti-rotation pin hole on both parts.
- D. Lower the diffuser bowl (30) onto the liner and suction bell to finish assembly.

CAUTION:

To avoid distortion, ensure proper installation of the liner. The liner should be firmly butted between the suction bell and diffuser bowl.

REPAIR PARTS:

Ordering parts:

When ordering parts, give pump serial number, size and model number and a complete description and item number of each part. Refer to the drawing and parts list in the back of this manual.

You may order parts from your local Fairbanks Nijhuis distributor. Consult your local telephone yellow pages under the heading - *Pumps*, for the office nearest you or visit FairbanksNijhuis.com to locate a distributor.

You may also order parts directly from the factory at the following address:

Fairbanks Nijhuis
 3501 Fairbanks Avenue
 Kansas City, KS 66106-0906
 (913) 371-5000
FairbanksNijhuis.com

Recommended Spare Parts:

Refer to Table 11 for a list of recommended spare parts. This list is for normal duty. Where severe conditions exist or minimum downtime is critical, additional quantities and those items indicated should be considered.

Predicted Life:

The predicted life of parts subject to wear, shown in Table 12, is based on pumping liquid without abrasives, the pump operating at sold conditions and that proper maintenance is performed.

The actual life encountered for the specific parts may vary significantly as a result of the content of liquid pumped, maintenance performed, actual operating conditions and other factors.

These predicted life figures are best engineering judgments and are not to be construed as an extension of warranty.

Table 11: Recommended Spare Parts

Ref. No.	Description	Quantity
13	Top Shaft Sleeve	1
15	Packing, Set	1
41	Bowl Throttle Ring	1
50	Bearing, Connector, Set	1
98	Bell Liner	1
163	Lower Bearing	1
168	Upper Bearing	1
28A	Head Gasket	1
63A	Seal Box Gasket	1

Table 12: Predicted Part Life

Ref. No.	Description	Predicted Life
1	Impeller	10 Years
4	Pump Shaft	10 Years
7	Discharge Head	20 Years
13	Top Shaft Sleeve	5 Years
15	Packing	1 Year
19	Top Line Shaft	10 Years
23	Line Shaft	10 Years
28	Column	20 Years
30	Diffuser Bowl	20 Years
31	Shaft Coupling	10 Years
33	Suction Bell	20 Years
50	Connector Bearing	10 Years
51	Enclosing Tube	20 Years
63	Packing Box	20 Years
63B	Packing Box Bushing	10 Years
98	Bell Liner	5 Years
163	Lower Bearing	10 Years
168	Upper Bearing	10 Years

Returning Parts:

All materials or parts returned to the factory MUST have prior approval and a "Returned Goods Tag", listing the material to be returned and the reasons for the return. All material to be returned should be carefully packed to avoid damage in route from rough handling or exposure to weather. Contact the factory for shipping instructions. All material is to be returned freight prepaid. Fairbanks Nijhuis makes improvements on its products from time to time and reserves the right to furnish improved parts for repairs. A part that is received and is not identical in appearance, or has a different symbol from the original part, may be interchangeable. Examine the part carefully before contacting your Fairbanks Nijhuis representative. The parts should never be returned to the factory without first obtaining proper authorization from your Fairbanks Nijhuis representative.

SERVICE:**Warranty Service:**

For warranty service contact the factory at:

Fairbanks Nijhuis
3501 Fairbanks Ave.
Kansas City, KS 66106-0906
(913) 371-5000

Service after Warranty:

For service after warranty on this pump or any other pumping equipment contact:

Pump Services Group
(800) 648-PUMP

or write:

Pump Services Group
Fairbanks Nijhuis
3501 Fairbanks Ave.
Kansas City, KS 66106-0906
(913) 371-5000

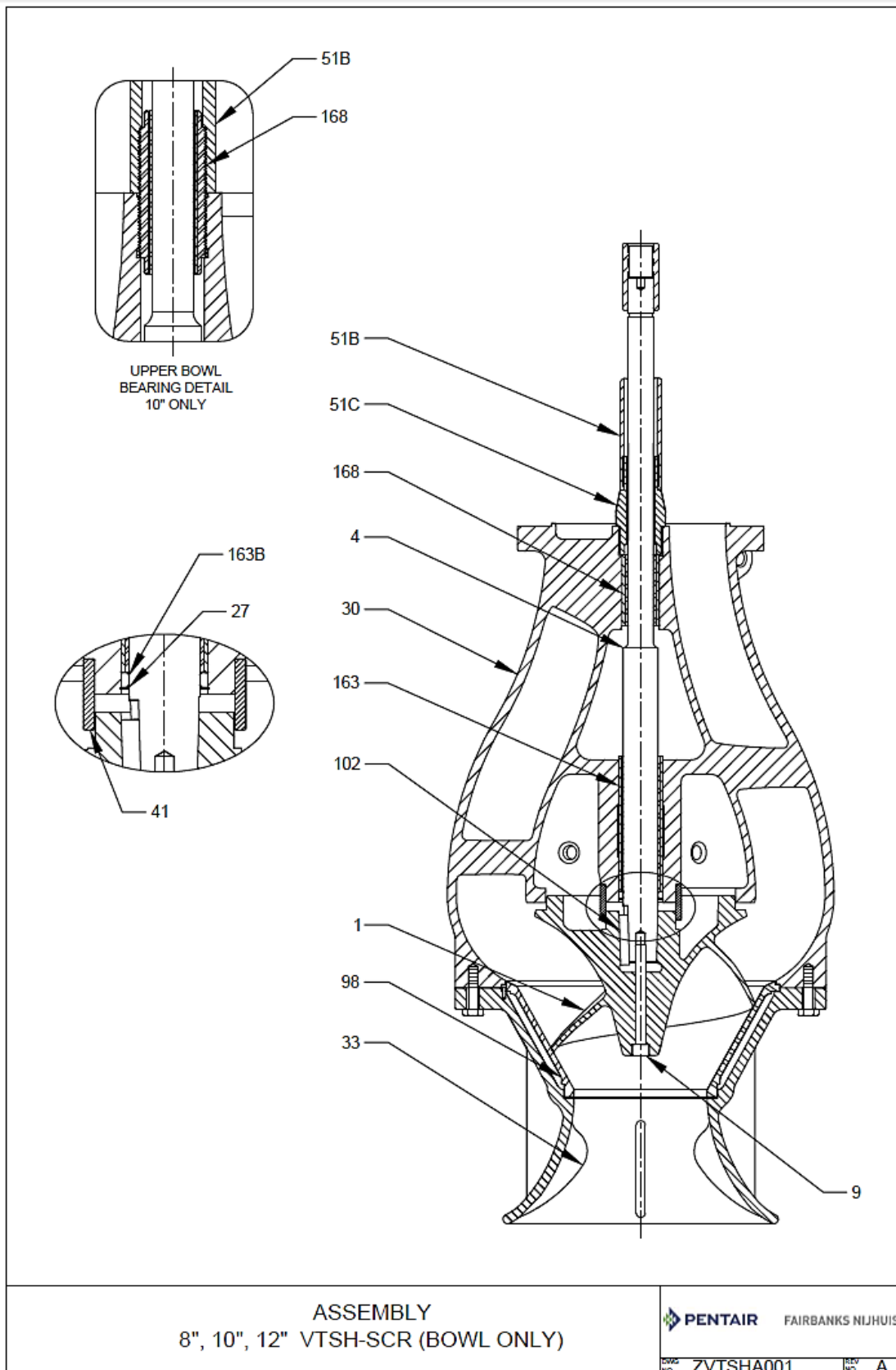

Assembly
8", 10", 12" VTSH-SCR (Bowl Only)

ITEM	DESCRIPTION	MATERIAL	SPECIFICATION
1	Impeller	Stainless Steel	A743 GR CF-8
4	Pump Shaft	Stainless Steel	A582 S41600 (Hard Chrome Plate)
9	Impeller Fastener	Steel	SAE J429 GR8
9A	Impeller Washer	Steel	A108 12L14
27	Ring, Retainer	Stainless Steel	AISI 302
30	Diffuser Bowl	Ductile Iron	A536
31	Coupling, Shaft	Stainless Steel	A582 S41600
33	Suction Bell	Ductile Iron	A536
41	Throttle Ring, Bowl	Stainless Steel	A743 GR CA-40 (300-350 Bhn)
50	Bearing, Connector	Stainless Steel	A743 GR CA-40 (300-350 Bhn)
51B	Enclosing Tube, Bottom	Stainless Steel	A743 GR CA-40 (300-350 Bhn)
51C (1)	Adapter, Enclosing Tube	Stainless Steel	A743 GR CA-40 (300-350 Bhn)
98	Liner, Suction Bell	25% Chrome Iron	A532 CLIII TYP A (550-600 Bhn)
102	Key, Impeller	Steel	A108 C10180
163	Bearing, Lower Bowl	Bronze Backed Rubber	Commercial
163B	Restrictor	PEEK	30% Glass Filled PEEK
168	Bearing, Upper Bowl	Bronze Backed Rubber	Commercial

(1) Not required on 10" VTSH-SCR

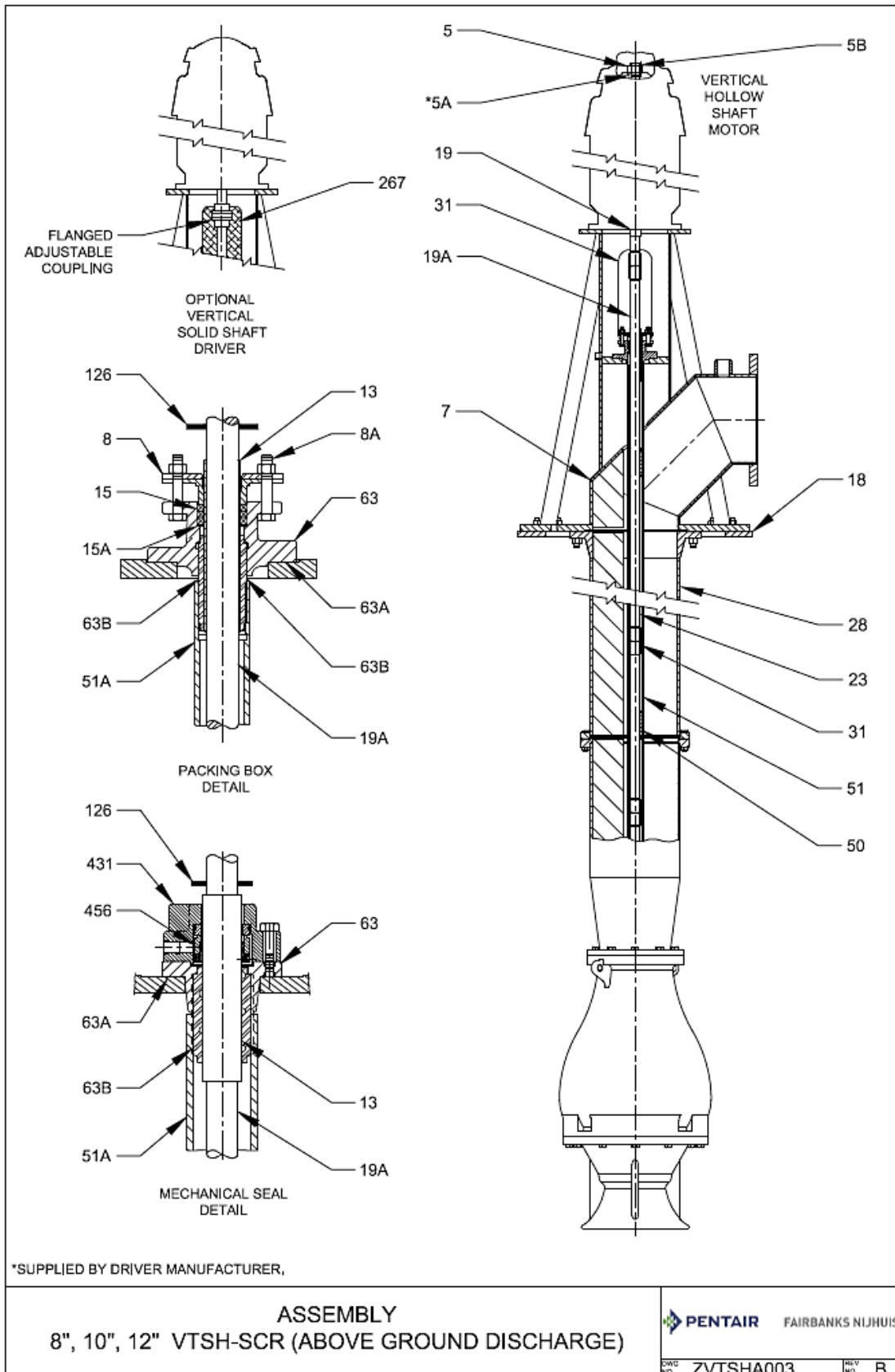

Assembly
8", 10", 12" VTSH-SCR
ABOVE GROUND DISCHARGE

ITEM	DESCRIPTION	MATERIAL	SPECIFICATION
5	Adjusting Nut	Steel	A108 GR 12L14
5A	Gib Key (by motor mfg.)	Steel	Commercial
5B	Locking Device	Hardware steel – zinc plated	Commercial
7	Discharge Head	Steel	A283 GR D / A36 AND A120
8	Gland, Packing Box	Cast Iron	A48-CL30
8A	Bolt & Nut, gland	Stainless steel	18-8
13	Sleeve, Top Shaft	Stainless steel	AISI 304
15	Packing	Synthetic, graphite impregnated	Commercial
15A	Washer, packing box	Stainless steel	18-8
18	Soleplate	Steel	A283 GR D
19	Driveshaft	Steel	AISI 1045
19A	Top Shaft	Stainless steel	A582 S41600
23	Lineshaft	Stainless steel	A582 S41600
28	Column Pipe, flanged	Steel	A120 AND A283 GR D
28A	Gasket, Head	Tag Board	D1190 GRAD 3111
31	Coupling, shaft	Stainless steel	A582 S41600
50	Bearing, connector	Bronze	B505 C93200
51	Enclosing Tube	Steel	A120
51A	Enclosing Tube, top	Steel	A120
51B	Enclosing Tube, bottom	Steel	A120
51C (1)	Adapter, Enclosing tube	Bronze	B505 C93200
63	Packing box	Cast Iron	A48-CL30
63A	Gasket, packing box	Copper	B152 C11000 025
63B	Bearing, packing box connector	Bronze	B505 C93200
126	Water slinger	Rubber	Neoprene
267	Guard, shaft	Steel	Commercial
OPTIONS			
456	Mechanical Seal	---	Commercial

(1) Not required on 10" VTSH-SCR

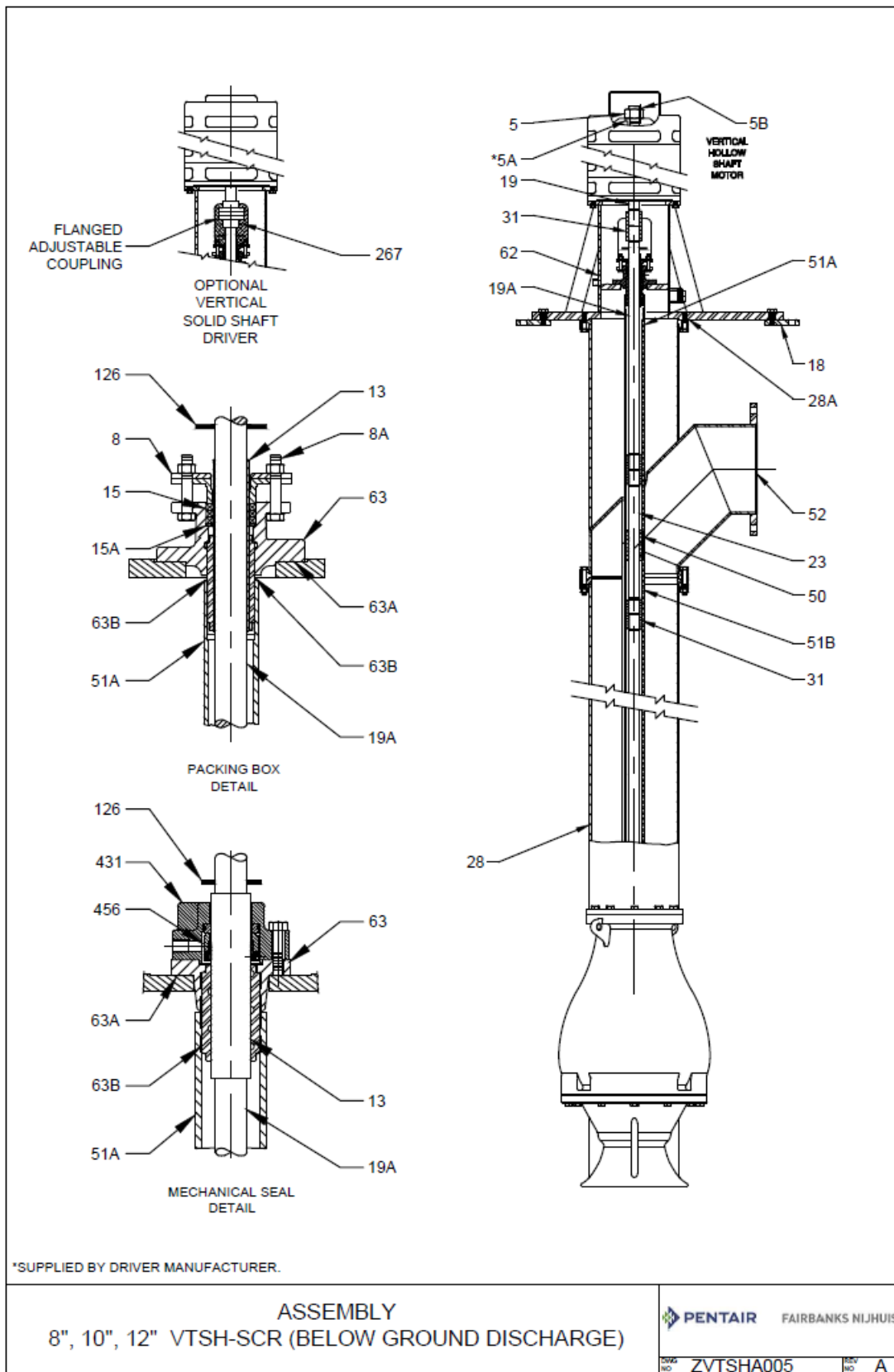

Assembly
8", 10", 12" VTSH-SCR
BELOW GROUND DISCHARGE

ITEM	DESCRIPTION	MATERIAL	SPECIFICATION
5	Adjusting Nut	Steel	A108 GR 12L14
5A	Gib Key (by motor mfg.)	Steel	Commercial
5B	Locking Device	Hardware Steel – Zinc Plated	Commercial
8	Gland, Packing Box	Cast Iron	A48-CL30
8A	Bolt & Nut, Gland	Stainless Steel	18-8
13	Sleeve, Top Shaft	Stainless Steel	AISI 304
15	Packing	Synthetic, Graphite Impregnated	Commercial
15A	Washer, Packing Box	Stainless Steel	18-8
18	Soleplate	Steel	A283 GR D
19	Driveshaft	Steel	AISI 1045
19A	Top Shaft	Stainless Steel	A582 S41600
23	Lineshaft	Stainless Steel	A582 S41600
28	Column Pipe, Flanged	Steel	A120 AND A283 GR D
28A	Gasket, Head	Tag Board	D1190 GRAD 3111
31	Coupling, Shaft	Stainless Steel	A582 S41600
50	Bearing, Connector	Bronze	B505 C93200
51	Enclosing Tube	Steel	A120
51A	Enclosing Tube, Top	Steel	A120
51B	Enclosing Tube, Bottom	Steel	A120
51C (1)	Adapter, Enclosing Tube	Bronze	B505 C93200
62	Pedestal	Steel	A283 GR D / A36 AND A120
63	Packing Box	Cast Iron	A48-CL30
63A	Gasket, Packing Box	Copper	B152 C11000 025
63B	Bearing, Packing Box Connector	Bronze	B505 C93200
126	Water Slinger	Rubber	Neoprene
267	Guard, Shaft	Steel	Commercial
OPTIONS			
456	Mechanical Seal	----	Commercial

(1) Not required on 10" VTSH-SCR

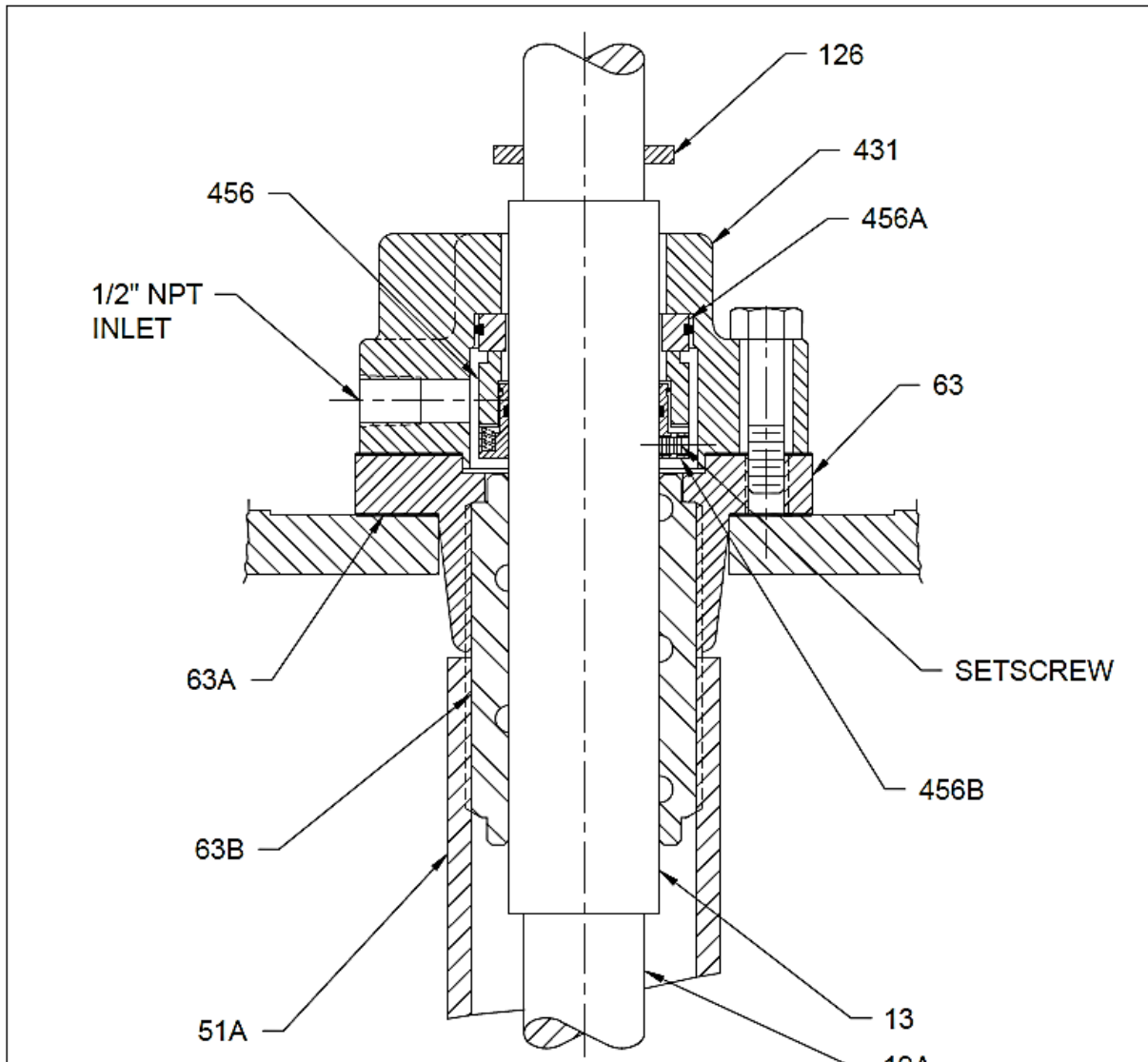

MATERIAL SPECIFICATION IS ASTM UNLESS OTHERWISE NOTED
 **REFER TO COMPLETE MATERIAL LIST FOR MATERIAL & SPECIFICATION

ITEM	DESCRIPTION	MATERIAL	SPECIFICATION
13	SLEEVE	**	**
19A	TOP SHAFT	**	**
51A	TOP ENCLOSING TUBE	STEEL	A120 SCH 80
63	SEAL BOX	CAST IRON	A48 CL 35
63A	GASKET	COPPER	B152 ALLOY 110
63B	CONNECTOR BEARING	BRONZE	B505 AL 932
126	DEFLECTOR	RUBBER	COMMERCIAL
431	SEAL GLAND	CAST IRON	A48 CL 35
456	ROTATING SEAT	CARBON	COMMERCIAL
456A	STATIONARY SEAT	CERAMIC	COMMERCIAL
456B	RETAINER	STAINLESS STEEL	316

**MECHANICAL SEAL ILLUSTRATION
 WATER-FLUSH LINESHAFT**



DWG NO WF-SEAL REV NO 1

THIS PAGE INTENTIONALLY LEFT BLANK

WARRANTY TO BE PLACED HERE