

# Hydraulic Coverage Chart – 2800 Horizontal Split Case Pumps

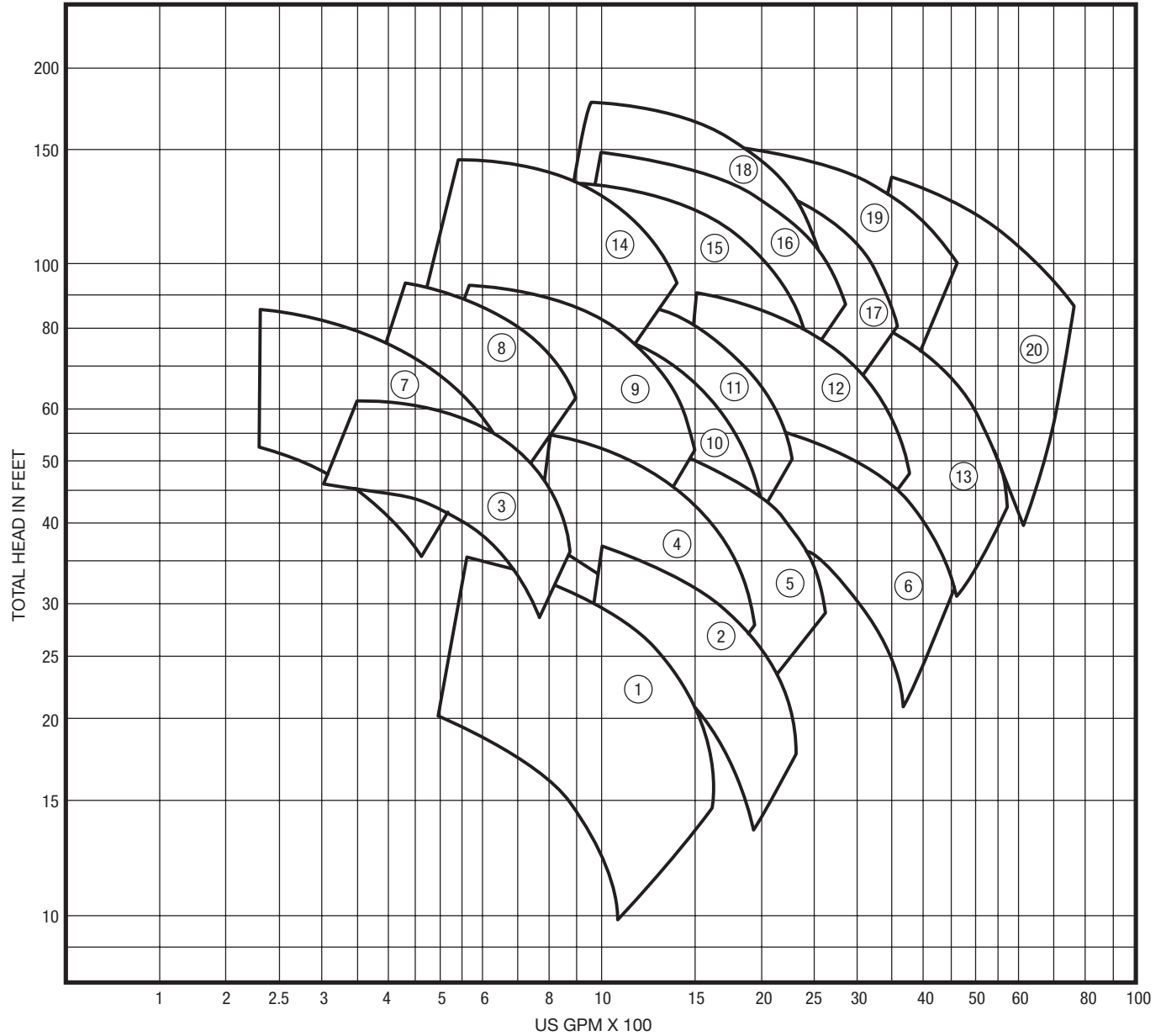

No.	Pump	RPM
1	6" 2821A	1170
2	8" 2821A	1175
3	6" 2822X	1180
4	6" 2822A	1175
5	8" 2822A	1180
6	10" 2822A	1185
7	3" 2823A	1175
8	4" 2823C	1175
9	5" 2823A	1180
10	6" 2823C	1180

No.	Pump	RPM
11	6" 2823A	1185
12	8" 2823A	1185
13	10" 2823A	1185
14	5" 2824A	1185
15	6" 2824C	1185
16	6" 2824A	1185
17	8" 2824A	1185
18	6" 2825A	1185
19	10" 2825C	1185
20	10" 2824A	1185

# Performance Curve - 2" 2873A

RPM: **3550** SOLIDS: **.38"**

IMPELLER: **J2B1B1** SUCTION: **4"** INLET: **8.64 in<sup>2</sup>**

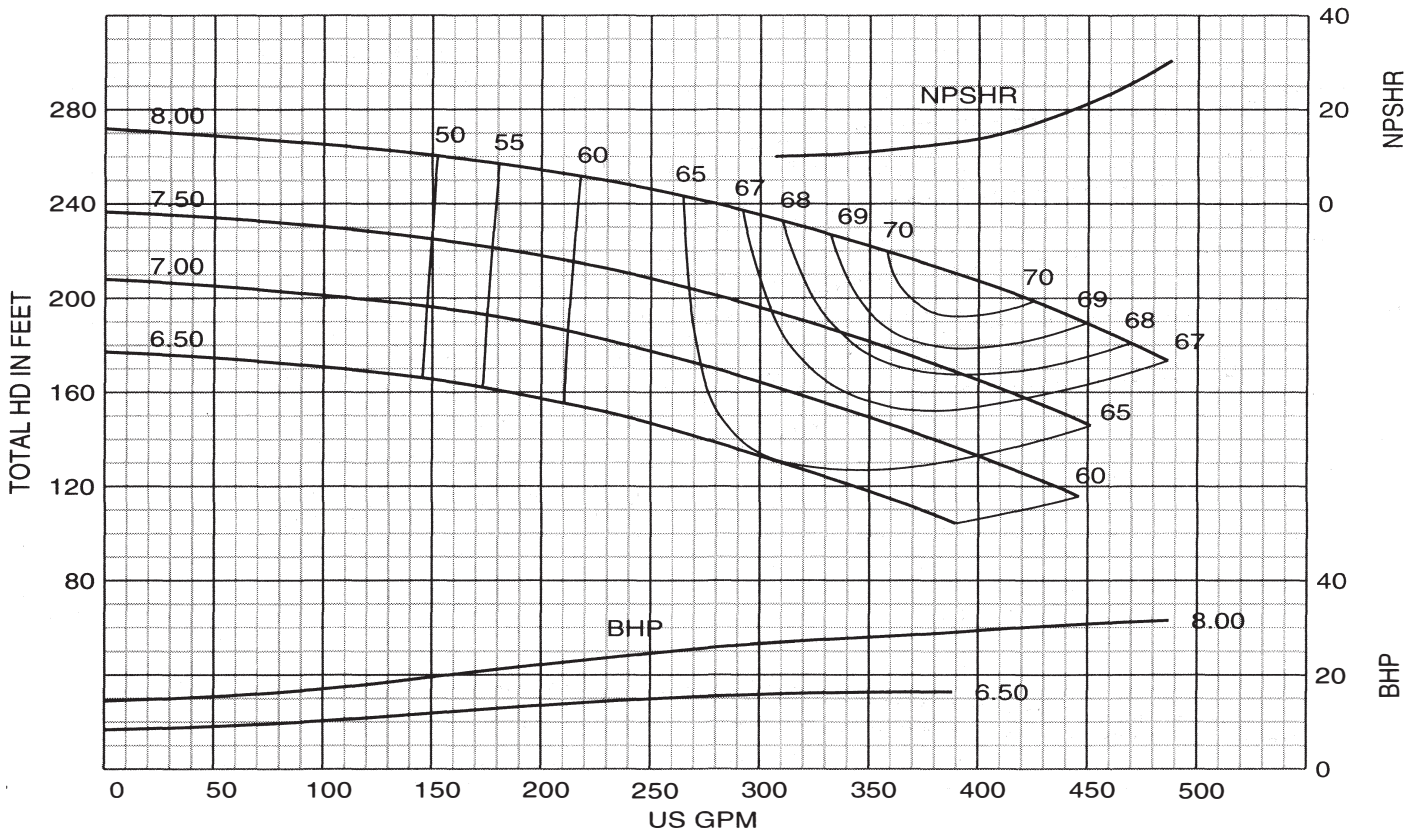

# Performance Curve - 4" 2873A

RPM: **3550** SOLIDS: **.50"**

IMPELLER: **J4B1A1** SUCTION: **6"** INLET: **15.90 in<sup>2</sup>**

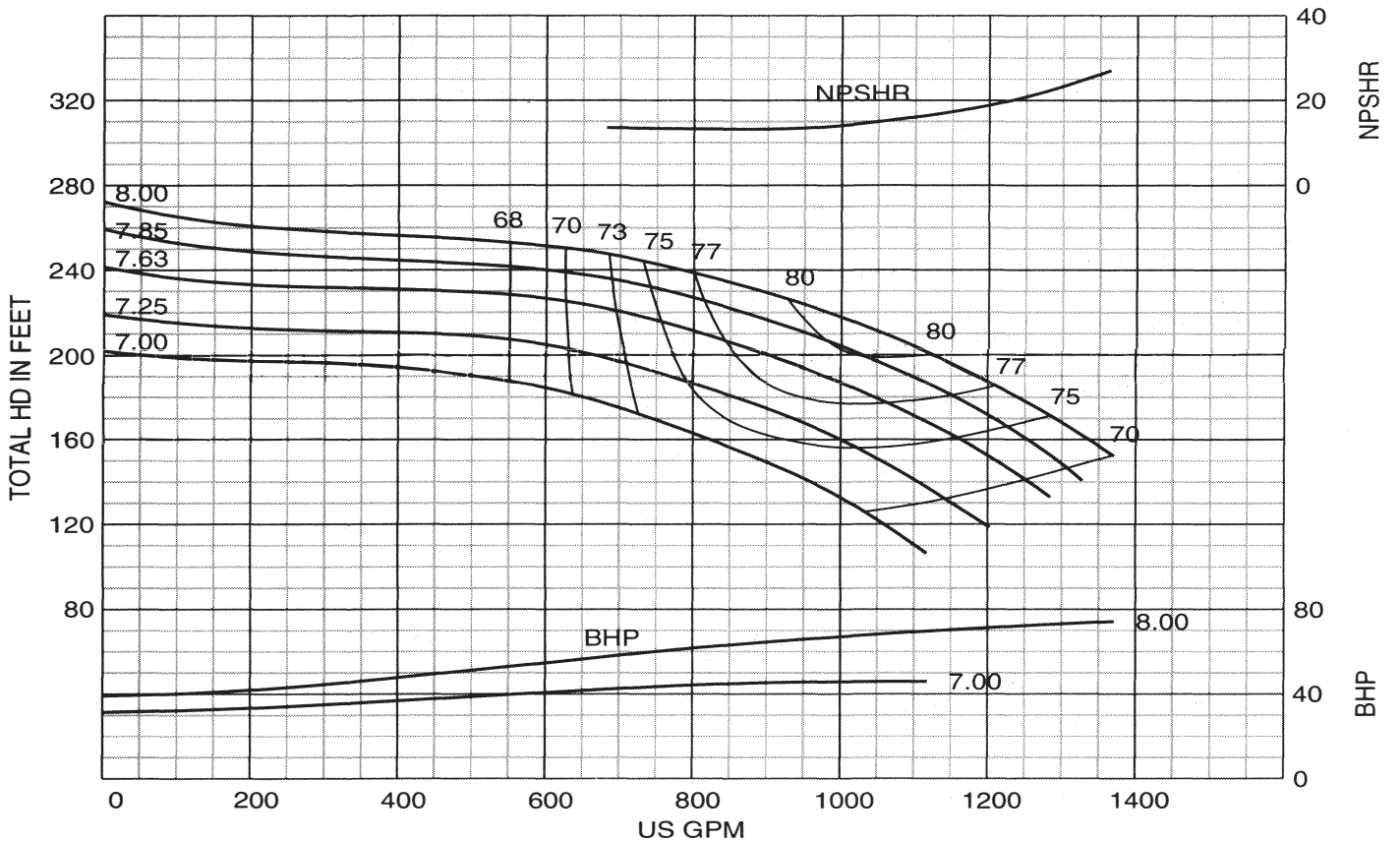

# Performance Curve - 3" 2874A

IMPELLER: J3C1A1 SUCTION: 5" INLET: 17.00 in<sup>2</sup>

RPM: 3570 SOLIDS: .63"

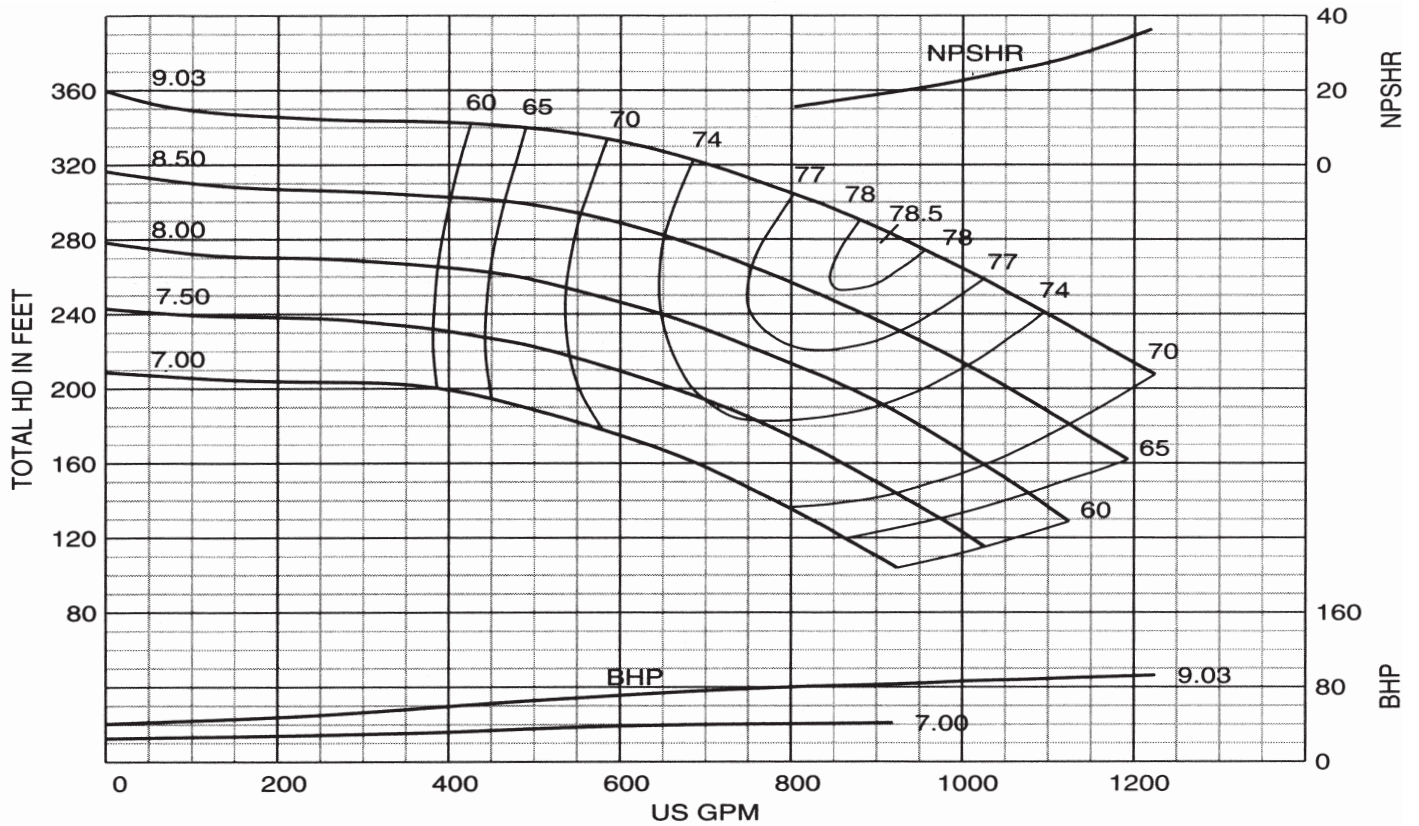

# Performance Curve - 3" 2874C

IMPELLER: J3C1C1 SUCTION: 5" INLET: 16.16 in<sup>2</sup>

RPM: 3570 SOLIDS: .50"

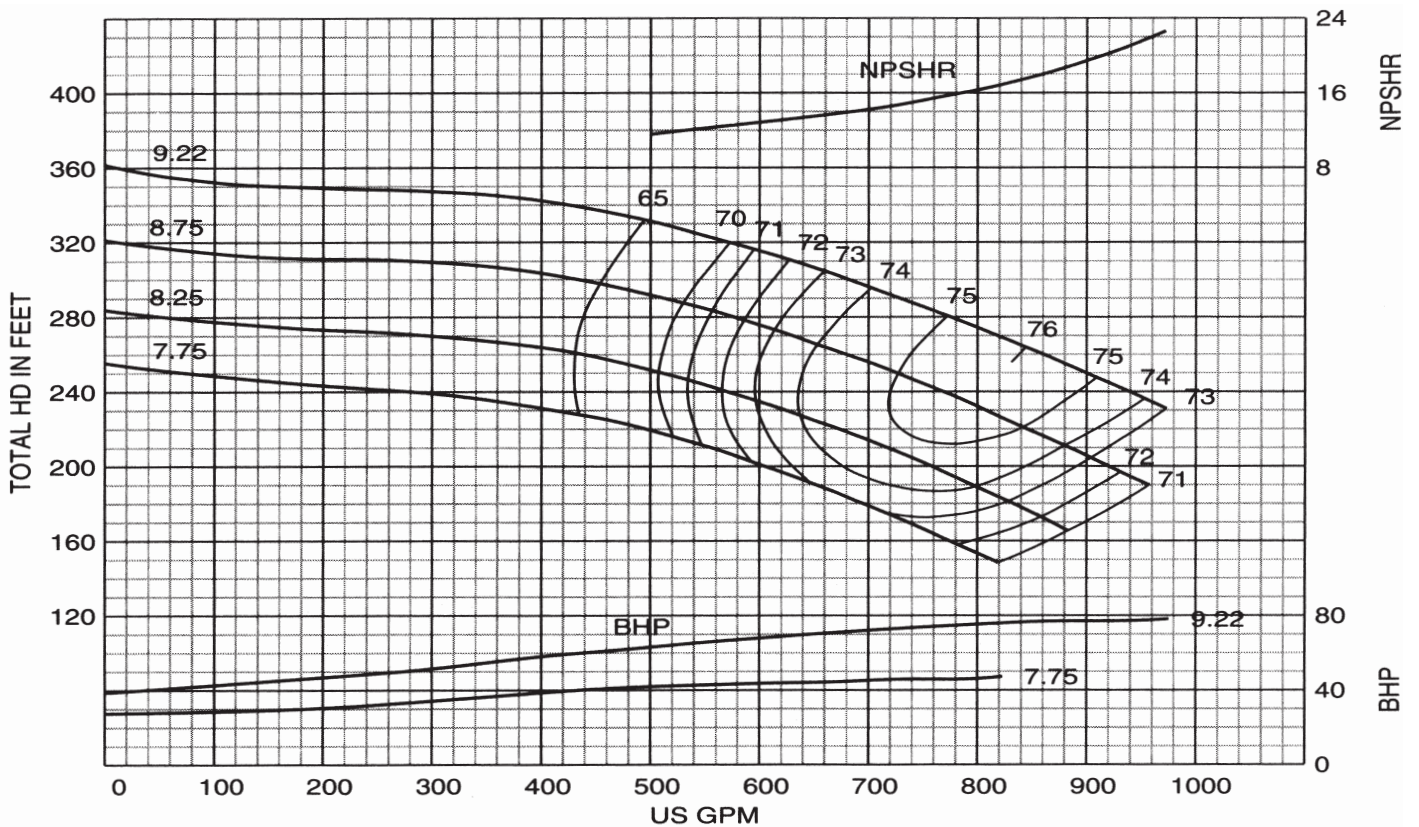

# Performance Curve - 4" 2874C

RPM: **3570** SOLIDS: **.50"**

IMPELLER: **J4C1C1** SUCTION: **6"** INLET: **25.08 in<sup>2</sup>**

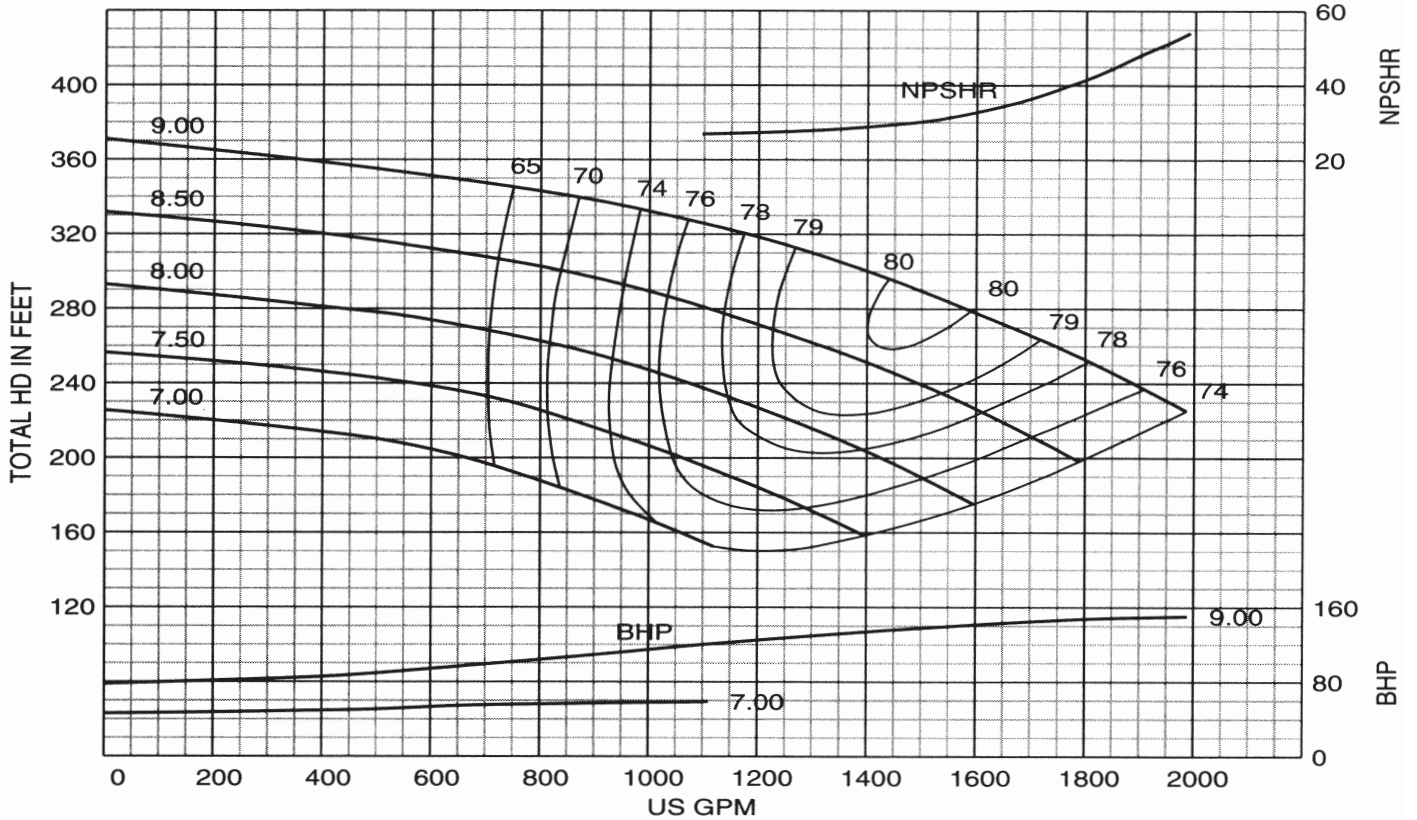

# Performance Curve - 5" 2874A

RPM: **3570** SOLIDS: **.86"**

IMPELLER: **J5C1A1** SUCTION: **8"** INLET: **34.24 in<sup>2</sup>**

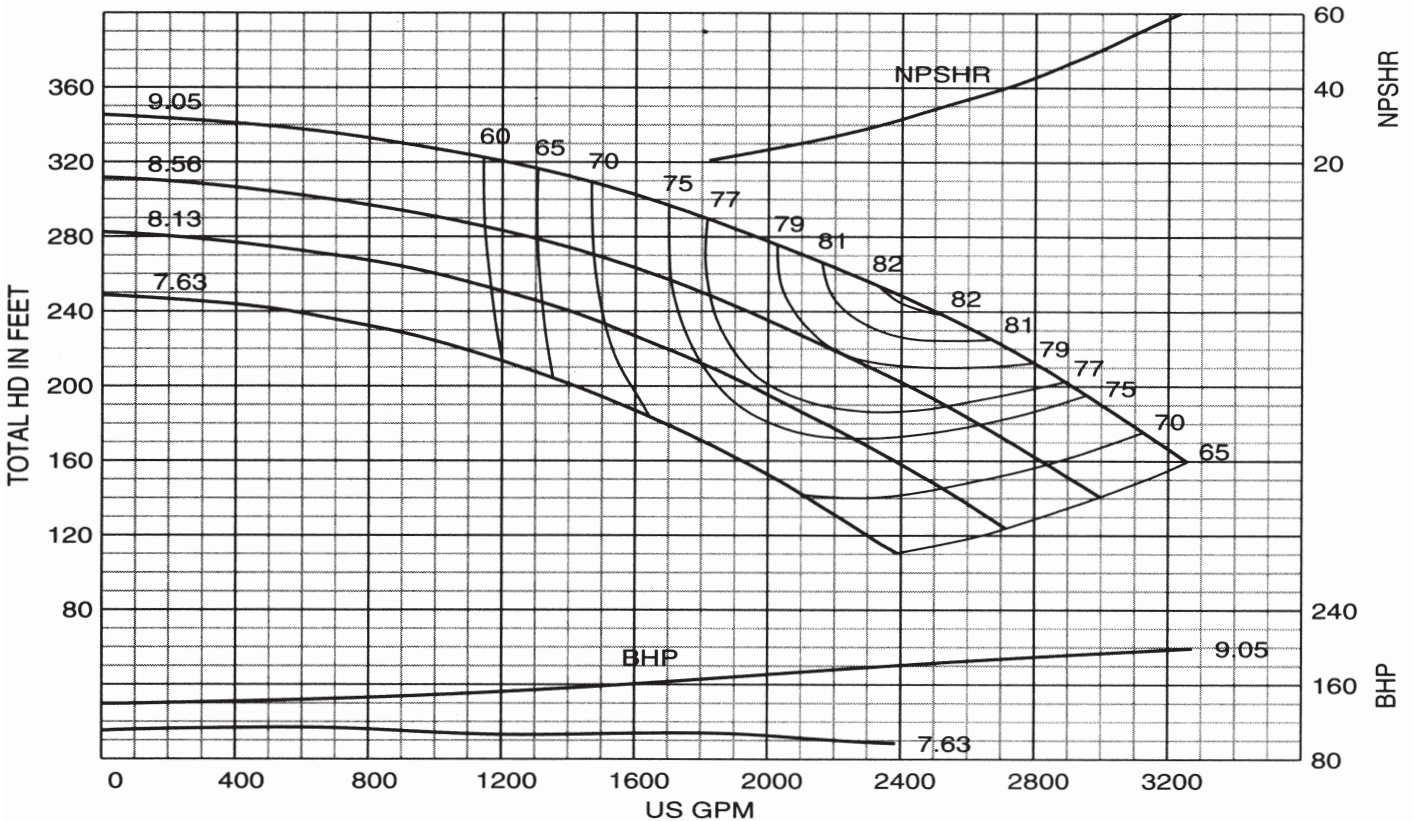

# Performance Curve - 4" 2876A

IMPELLER: J4E1A1 SUCTION: 6" INLET: 25.02 in<sup>2</sup>

RPM: 3565 SOLIDS: .50"

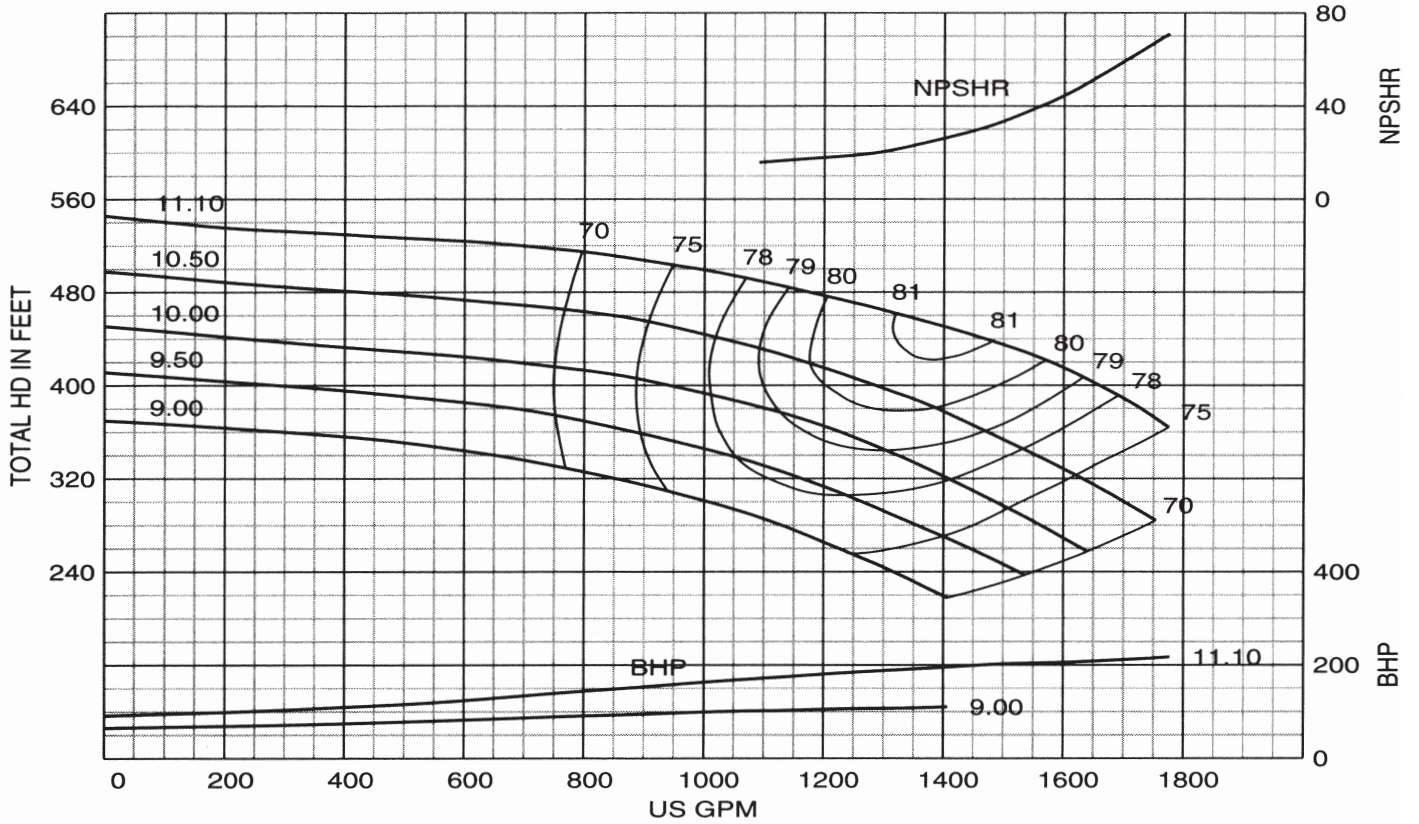

# Performance Curve - 4" 2876C

IMPELLER: J4E1C1 SUCTION: 6" INLET: 25.02 in<sup>2</sup>

RPM: 3565 SOLIDS: .60"

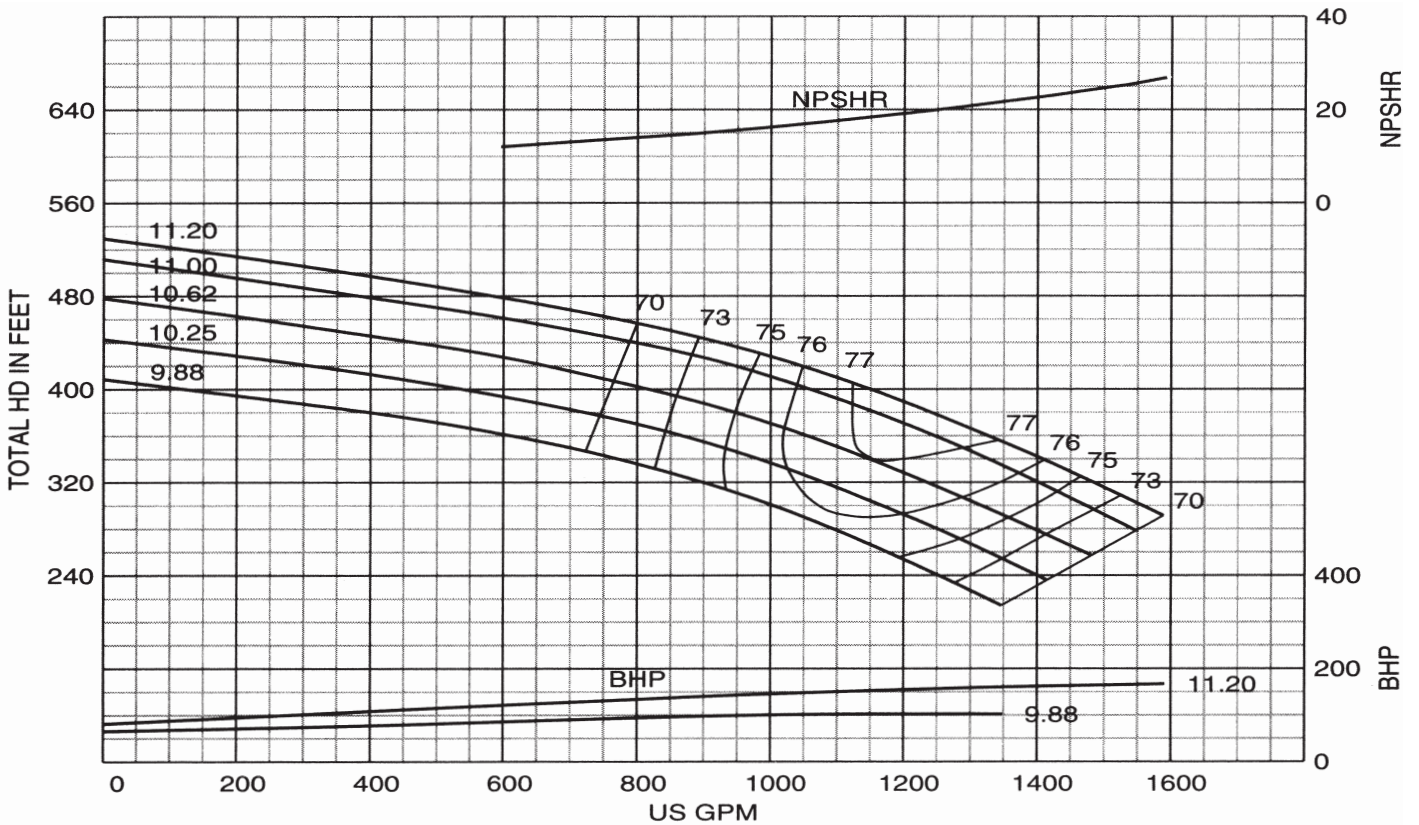

# Performance Curve - 5" 2876A

IMPELLER: J5E1A1 SUCTION: 8" INLET: 42.12 in<sup>2</sup>

RPM: 3565 SOLIDS: .75"

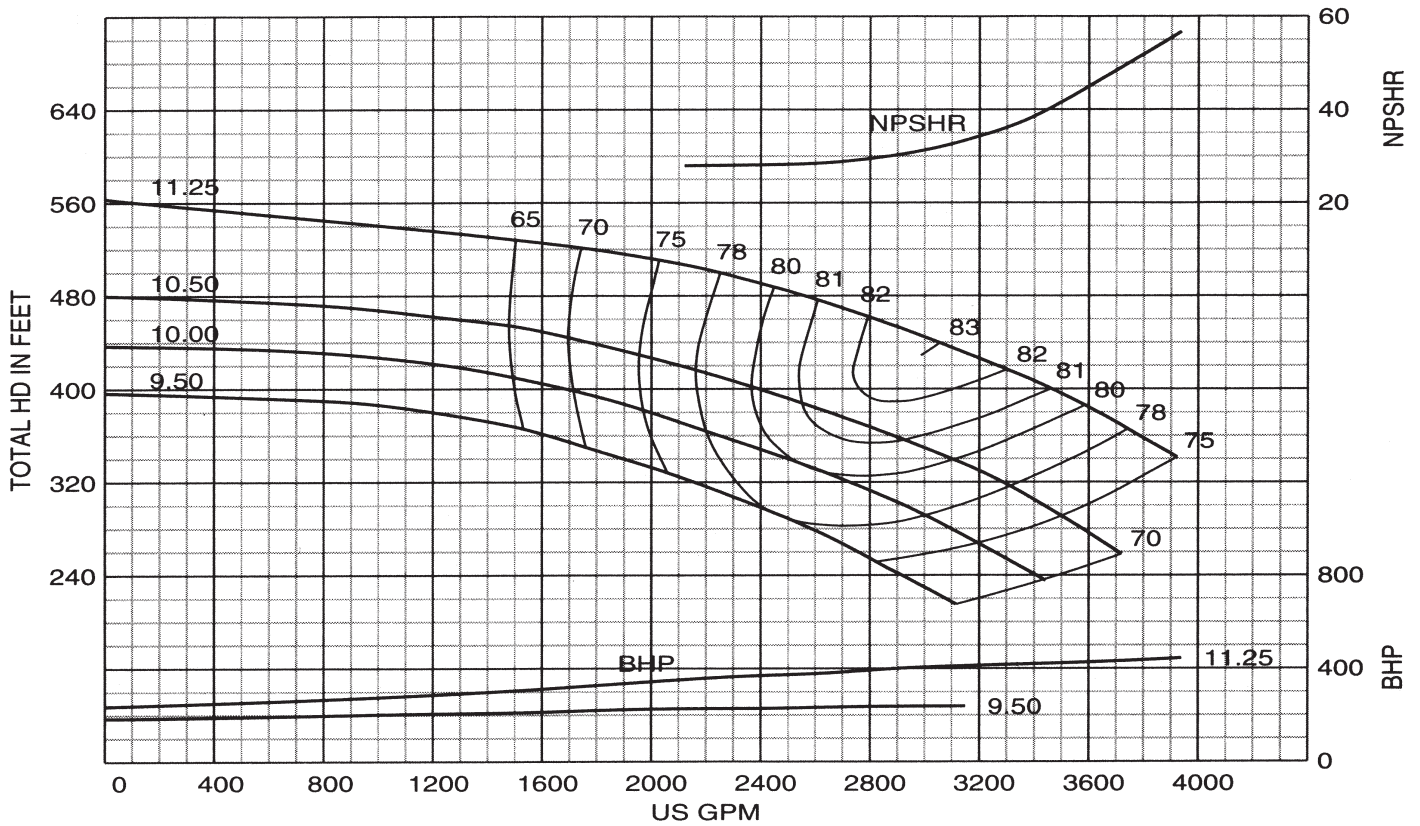

# Performance Curve - 6" 2821A

IMPELLER: J6C1A1 SUCTION: 8" INLET: 44.4 in<sup>2</sup>

RPM: 1775 SOLIDS: .88"

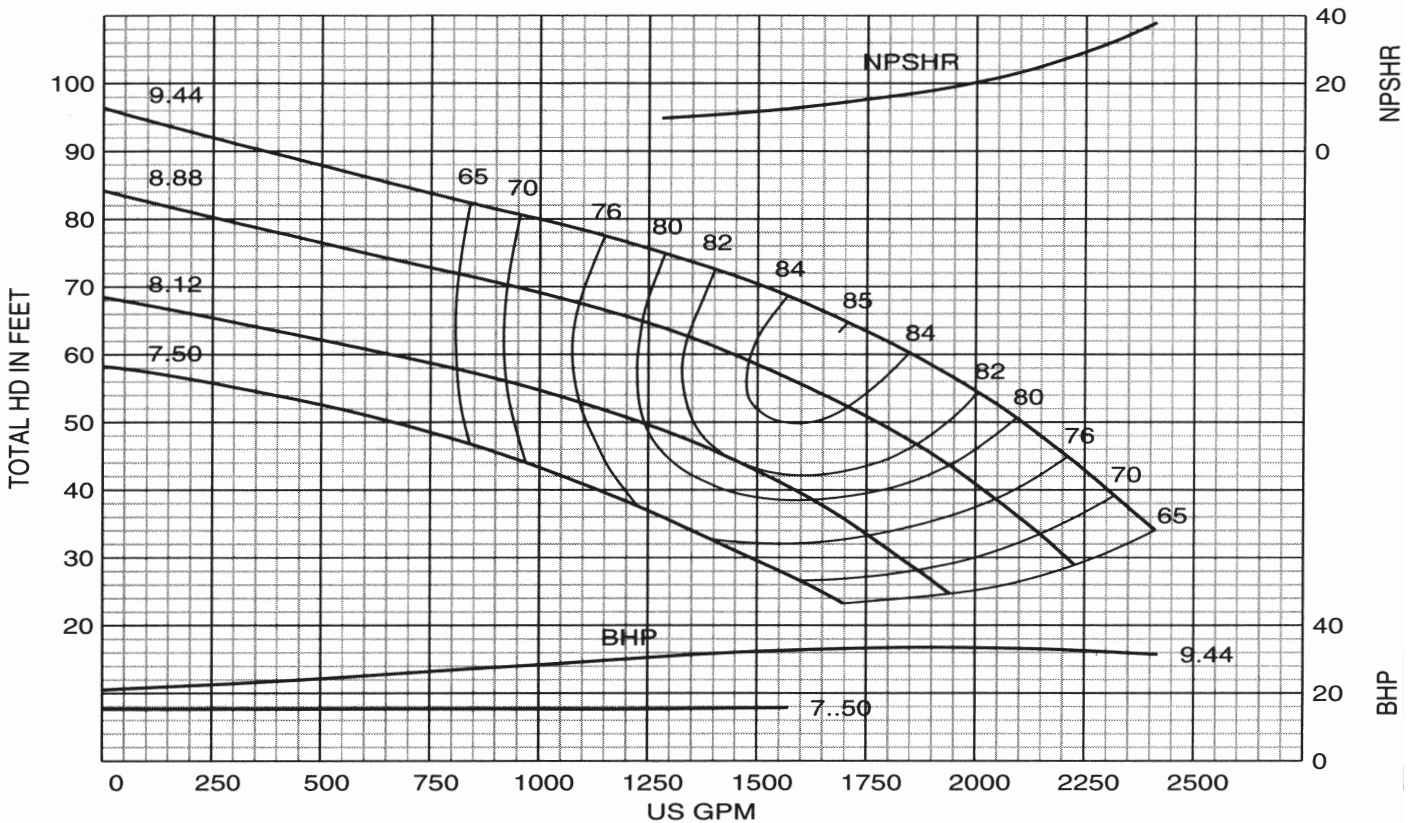

# Performance Curve – 8" 2821A

IMPELLER: J8C1A3 SUCTION: 10" INLET: 64.55 in<sup>2</sup>

RPM: 1775 SOLIDS: .88"

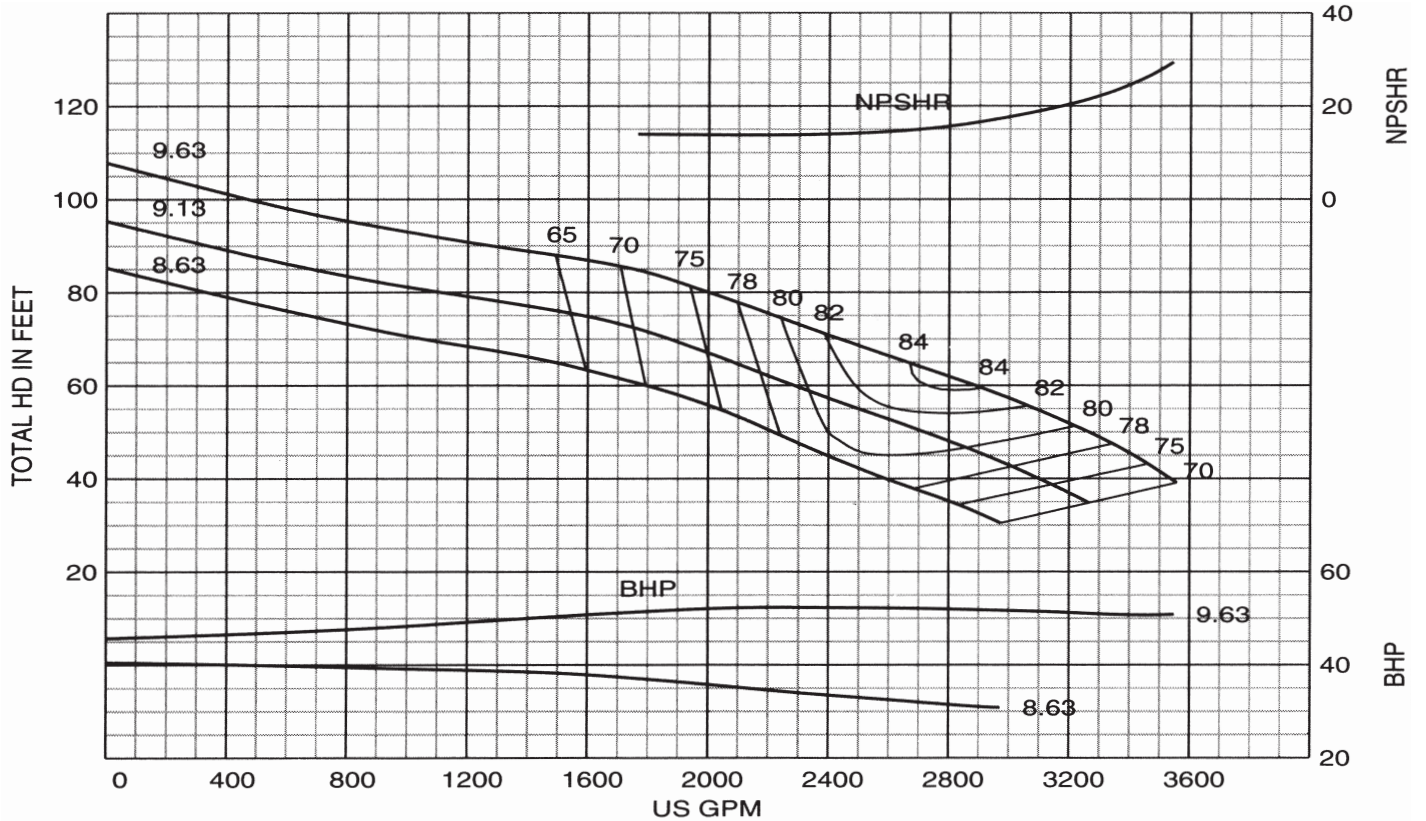

# Performance Curve – 6" 2822A

IMPELLER: J6E1A1 SUCTION: 10" INLET: 48.06 in<sup>2</sup>

RPM: 1780 SOLIDS: 1.06"

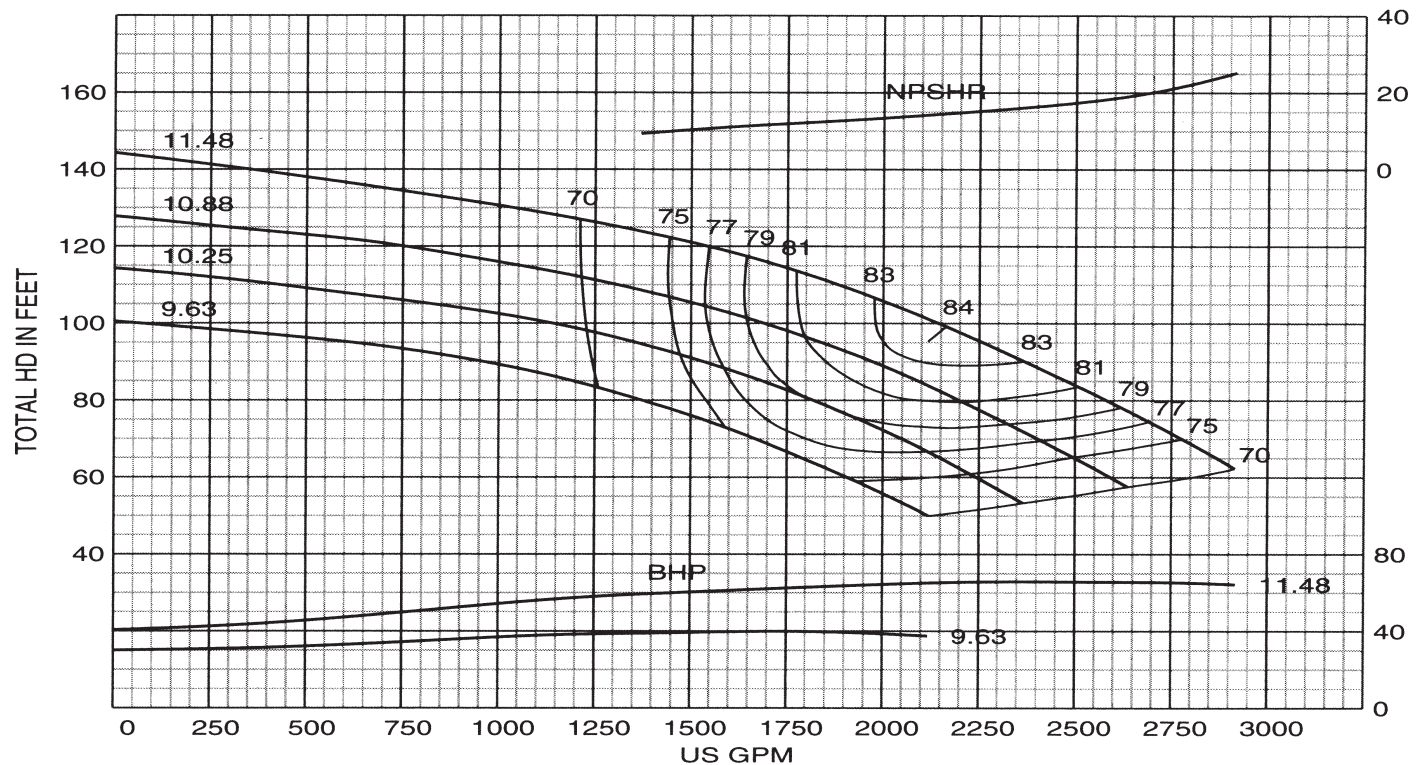

# Performance Curve - 6" 2822X

IMPELLER: J6E1F SUCTION: 6" INLET: 25.52 in<sup>2</sup>

RPM: 1775 SOLIDS: .437"

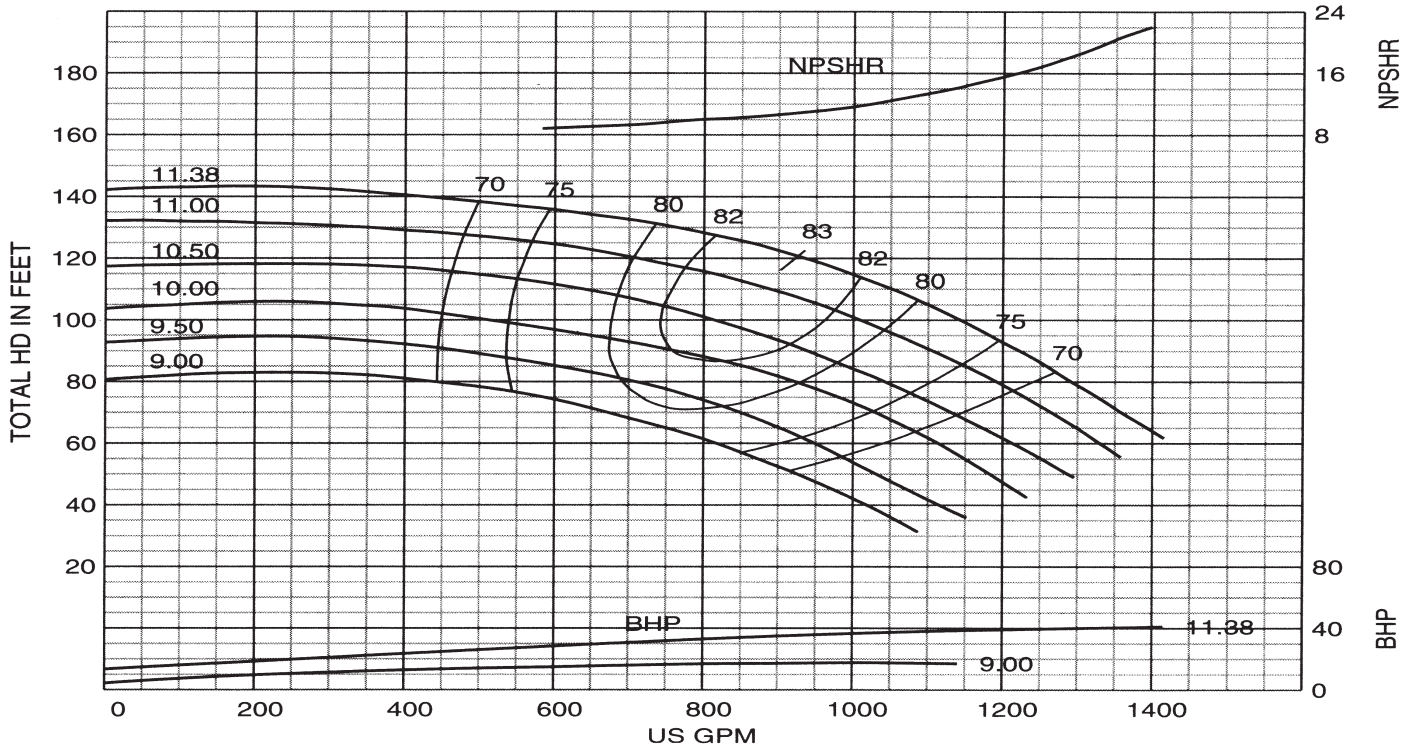

# Performance Curve - 8" 2822A

IMPELLER: J8E1A1 SUCTION: 8" INLET: 57.5 in<sup>2</sup>

RPM: 1780 SOLIDS: 1.25"

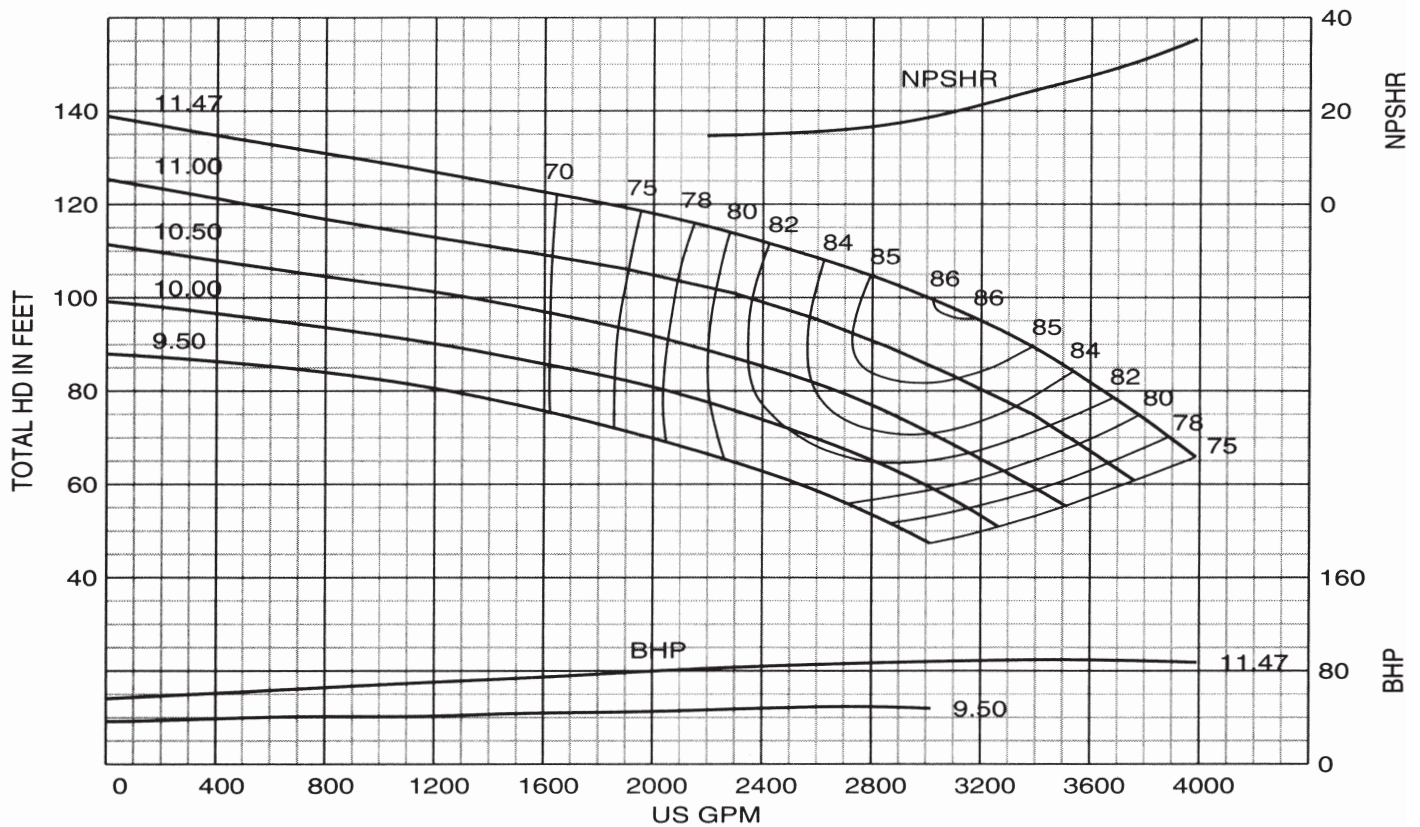



# Performance Curve – 10" 2822A

RPM: 1785 SOLIDS: 1.00"

IMPELLER: J10E1A3 SUCTION: 14" INLET: 103.40 in<sup>2</sup>

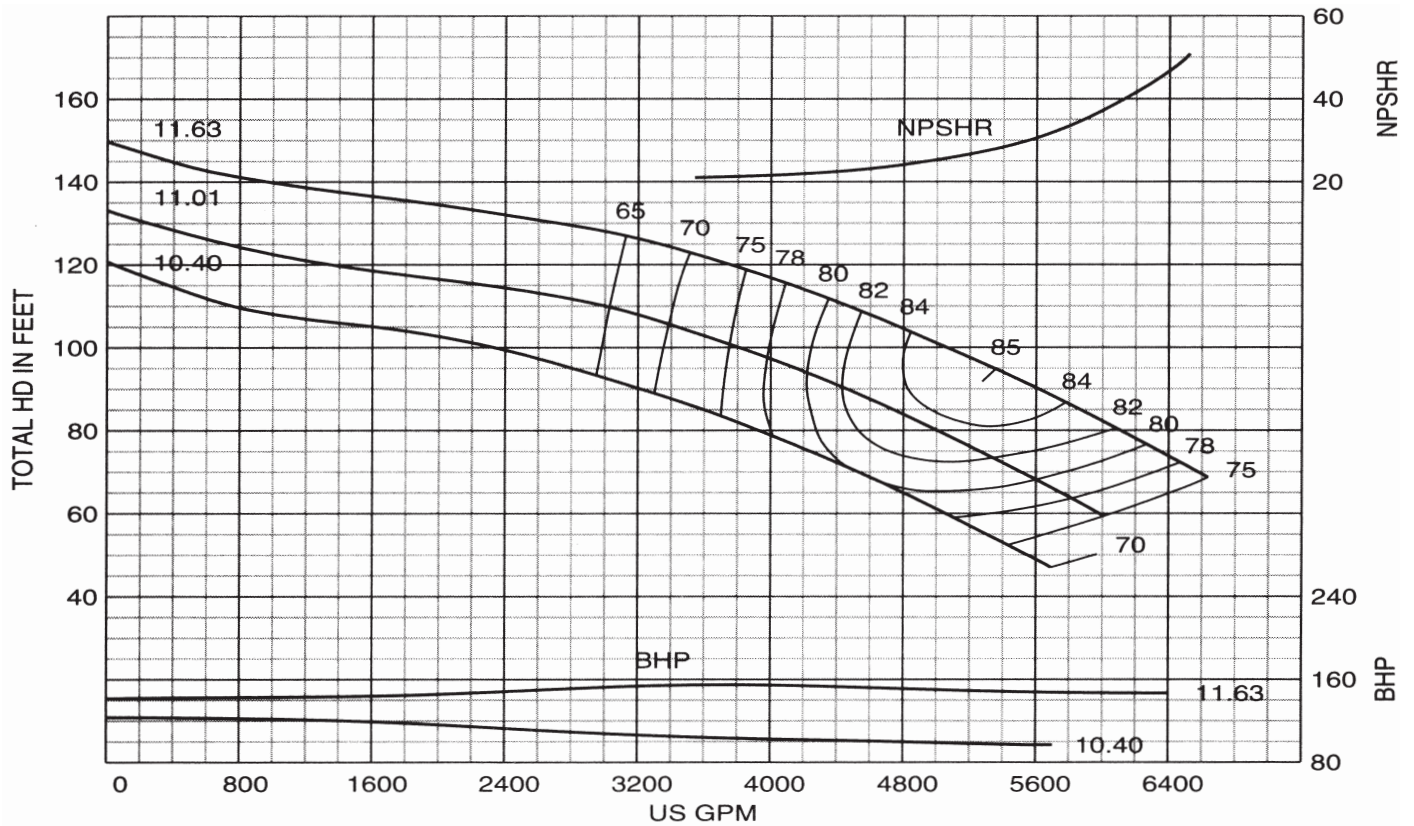

# Performance Curve – 3" 2823A

RPM: 1775 SOLIDS: .54"

IMPELLER: J3H1A1 SUCTION: 5" INLET: 16.40 in<sup>2</sup>

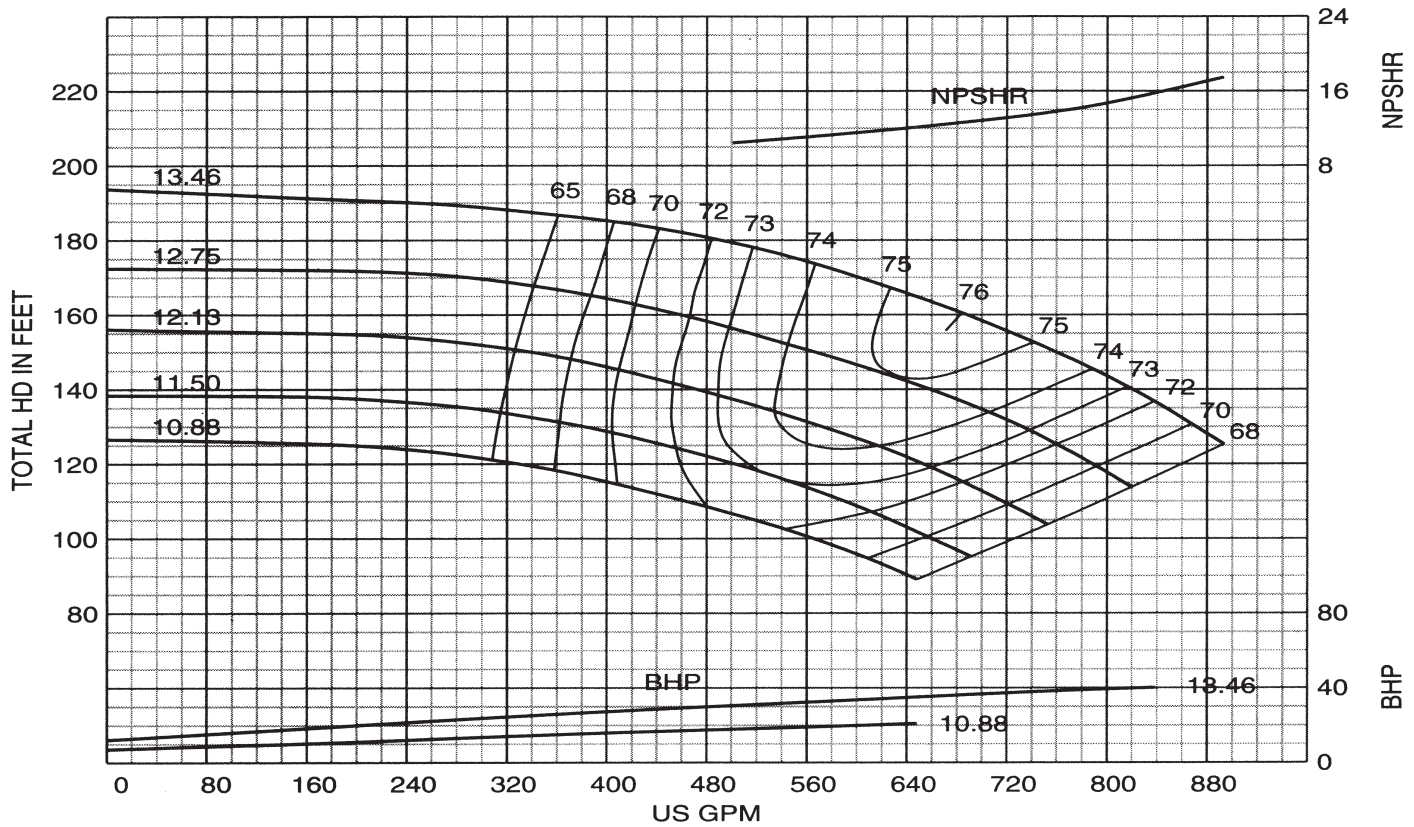

# Performance Curve - 4" 2823C

RPM: 1780 SOLIDS: .63"

IMPELLER: J4H1C1 SUCTION: 6" INLET: 24.72 in<sup>2</sup>

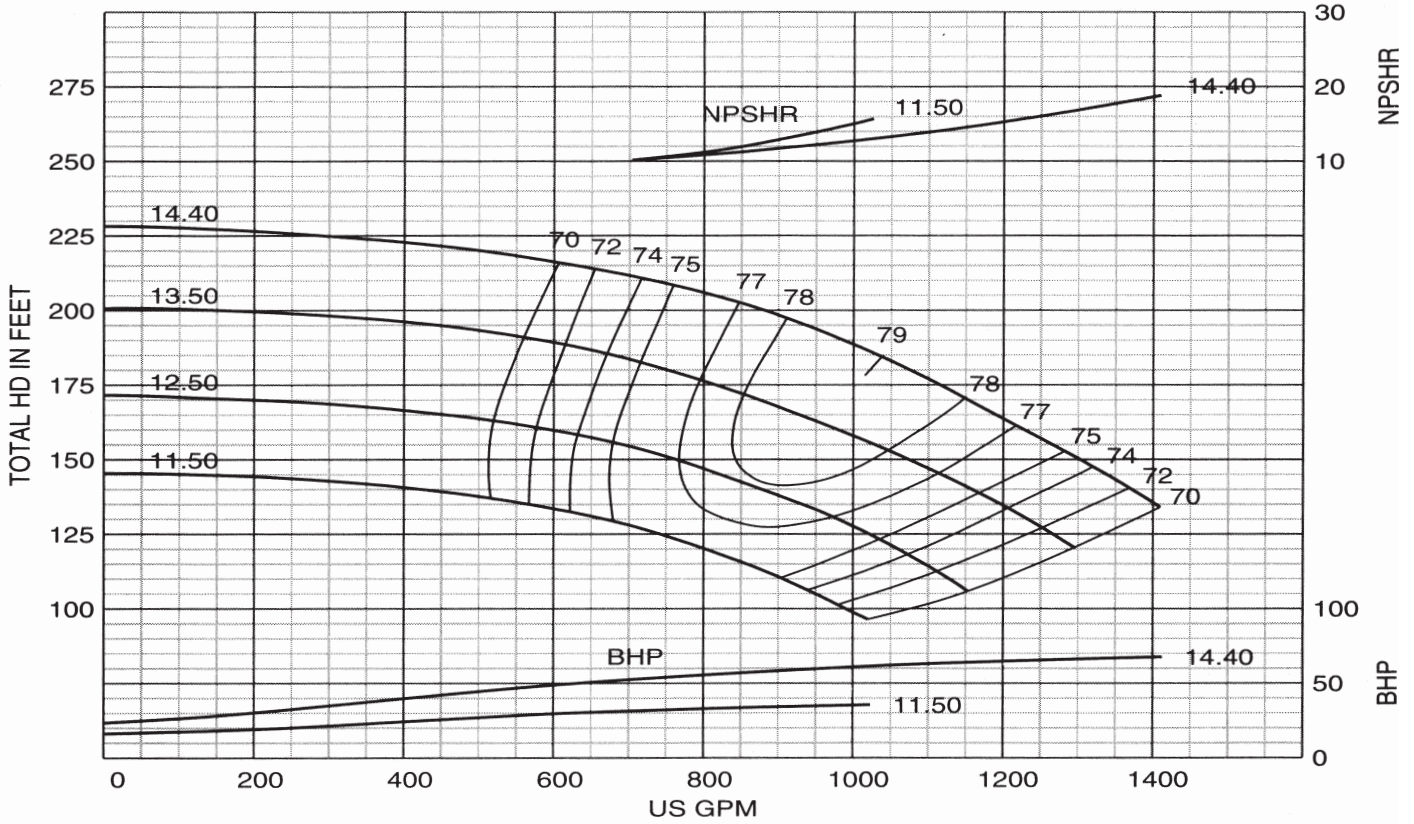

# Performance Curve - 5" 2823A

RPM: 1780 SOLIDS: .95"

IMPELLER: J5H1A1 SUCTION: 8" INLET: 35.80 in<sup>2</sup>

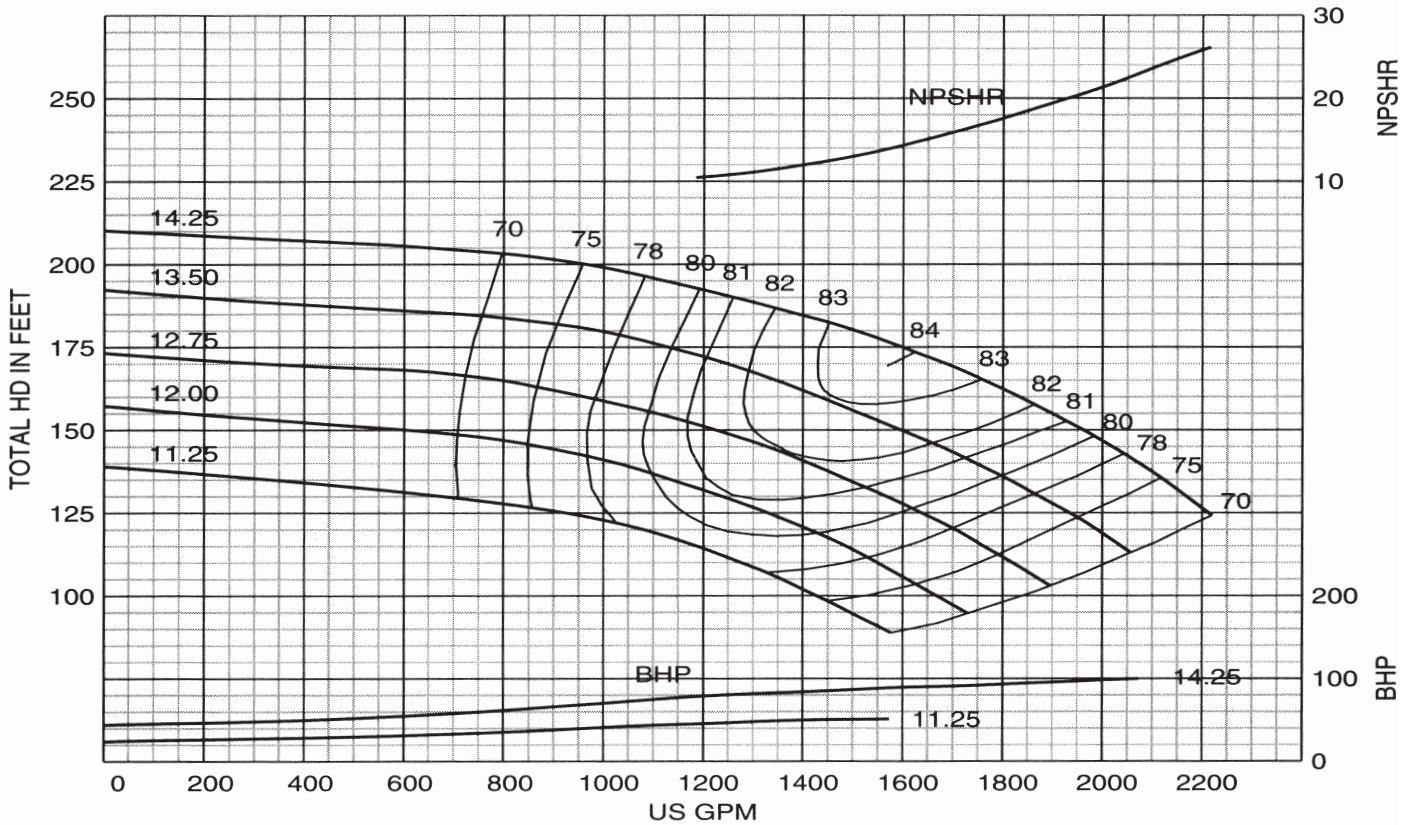

# Performance Curve – 6" 2823A

IMPELLER: J6H1A1 SUCTION: 10" INLET: 55.50 in<sup>2</sup>

RPM: 1785 SOLIDS: 1.00"

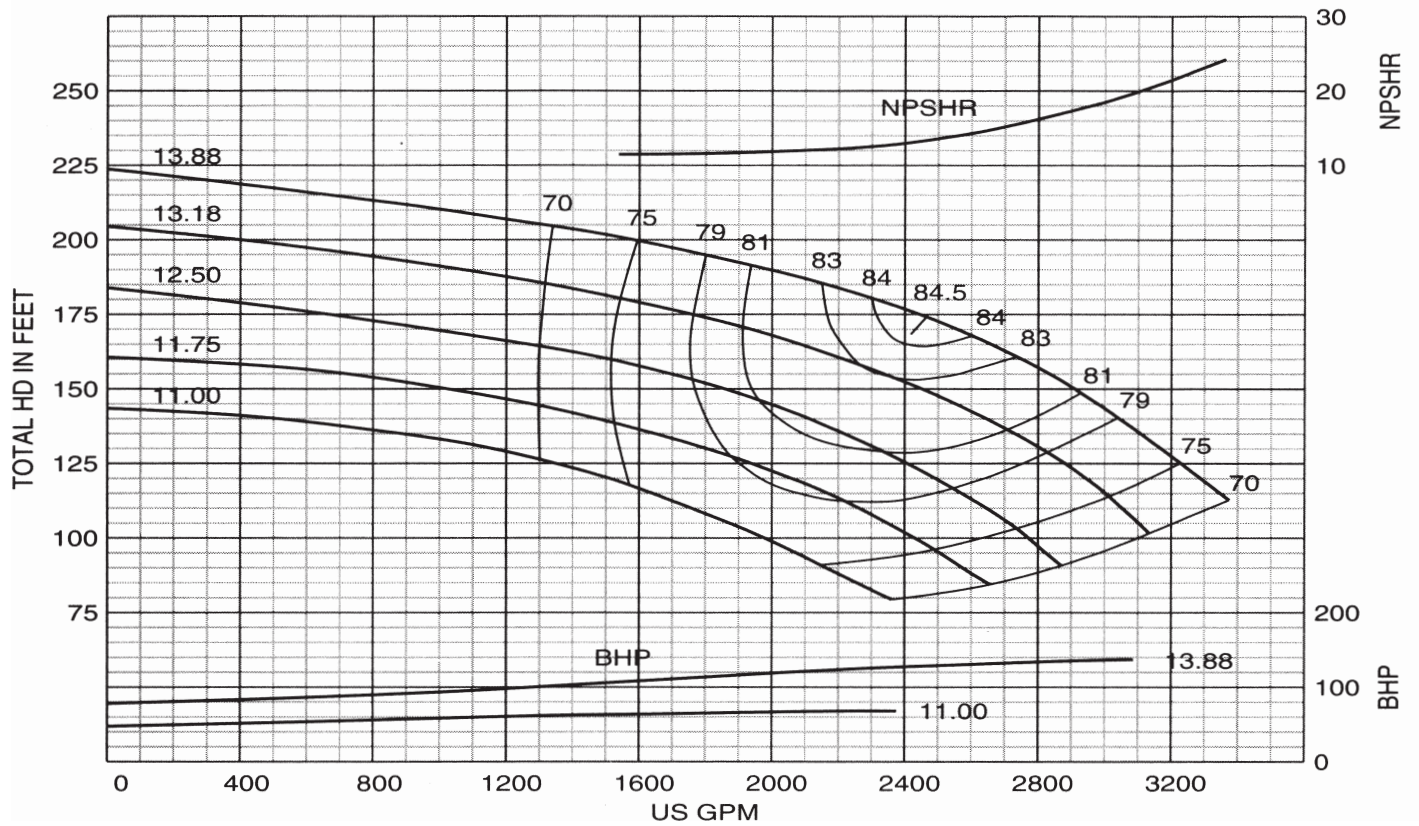

# Performance Curve – 6" 2823C

IMPELLER: J6H1C1 SUCTION: 10" INLET: 53.46 in<sup>2</sup>

RPM: 1780 SOLIDS: 1.00"

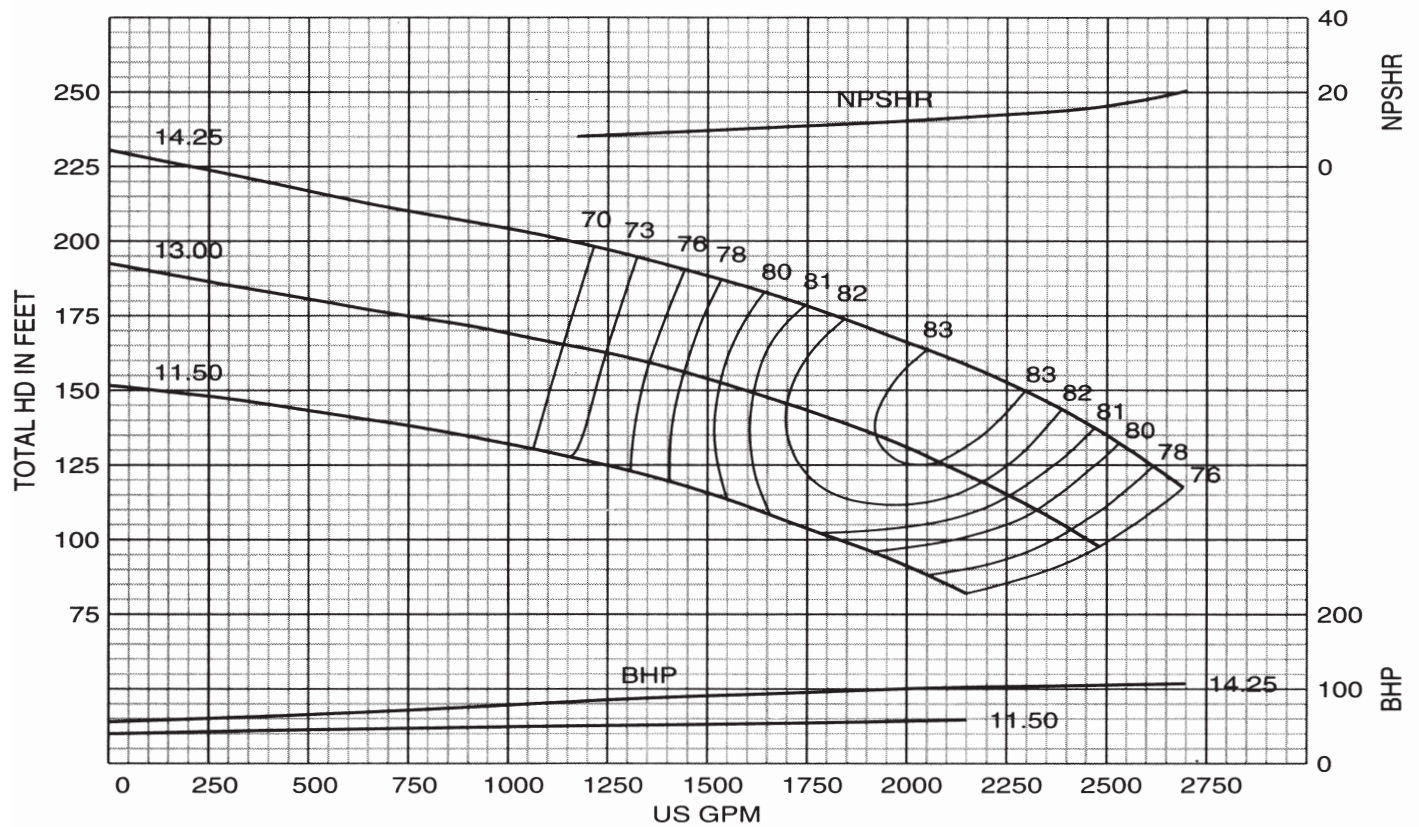

# Performance Curve - 8" 2823A

RPM: 1785 SOLIDS: 1.12"

IMPELLER: J8H1A3 SUCTION: 12" INLET: 80.20 in<sup>2</sup>

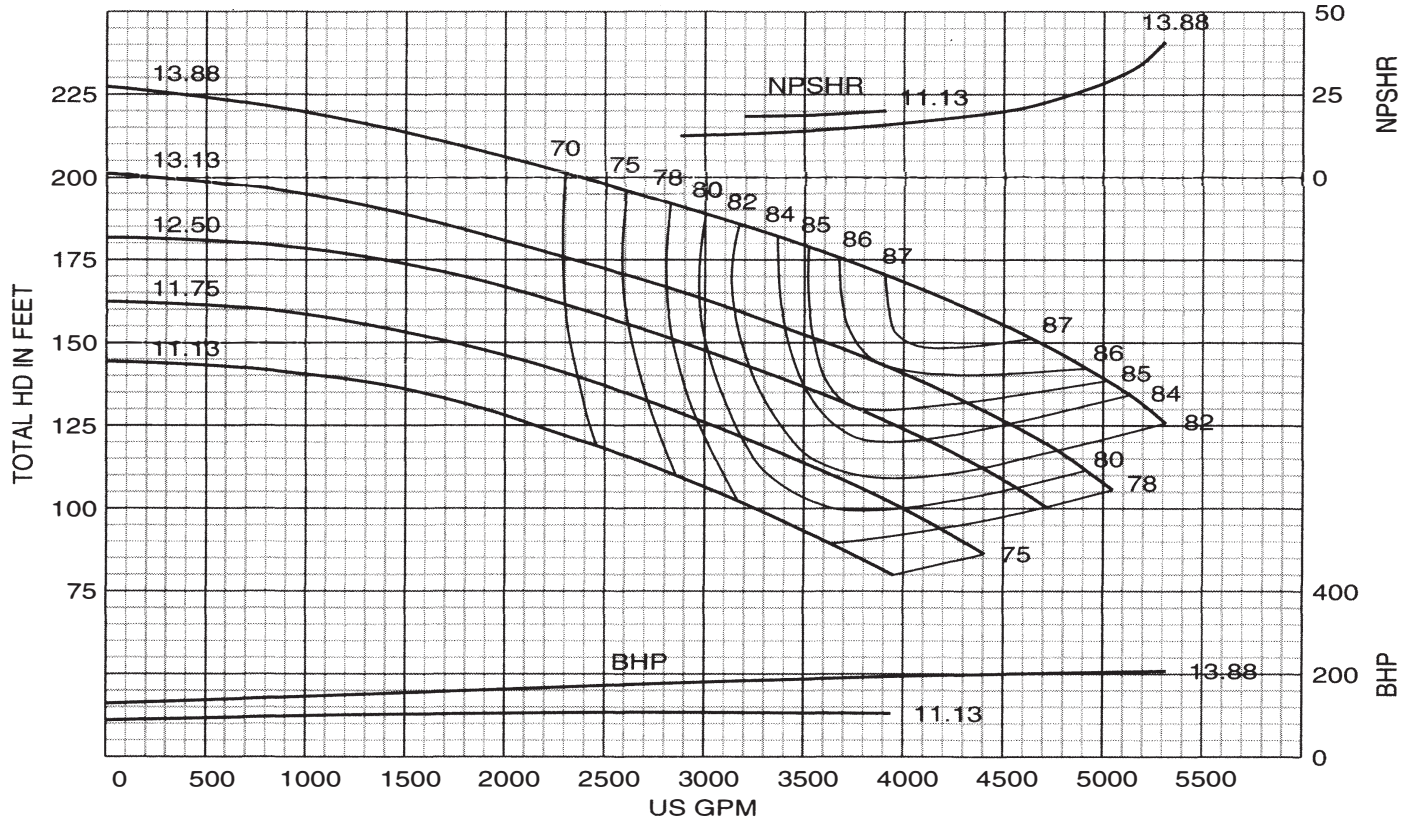

# Performance Curve - 10" 2823A

RPM: 1785 SOLIDS: 1.22"

IMPELLER: J10H1A3 SUCTION: 14" INLET: 108.56 in<sup>2</sup>

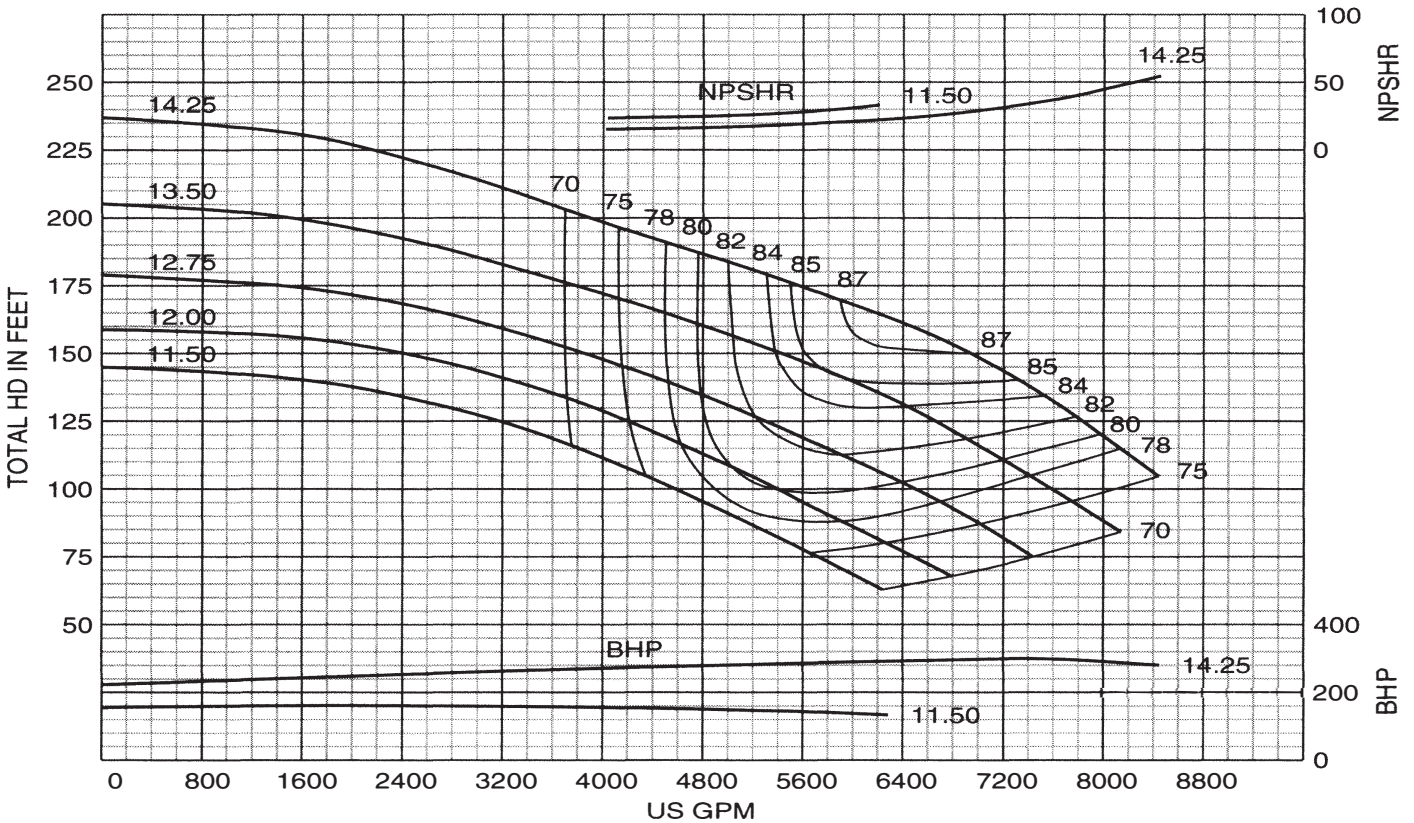

# Performance Curve - 5" 2824A

IMPELLER: J5L1A1 SUCTION: 8" INLET: 33.38 in<sup>2</sup>

RPM: 1785 SOLIDS: .63"

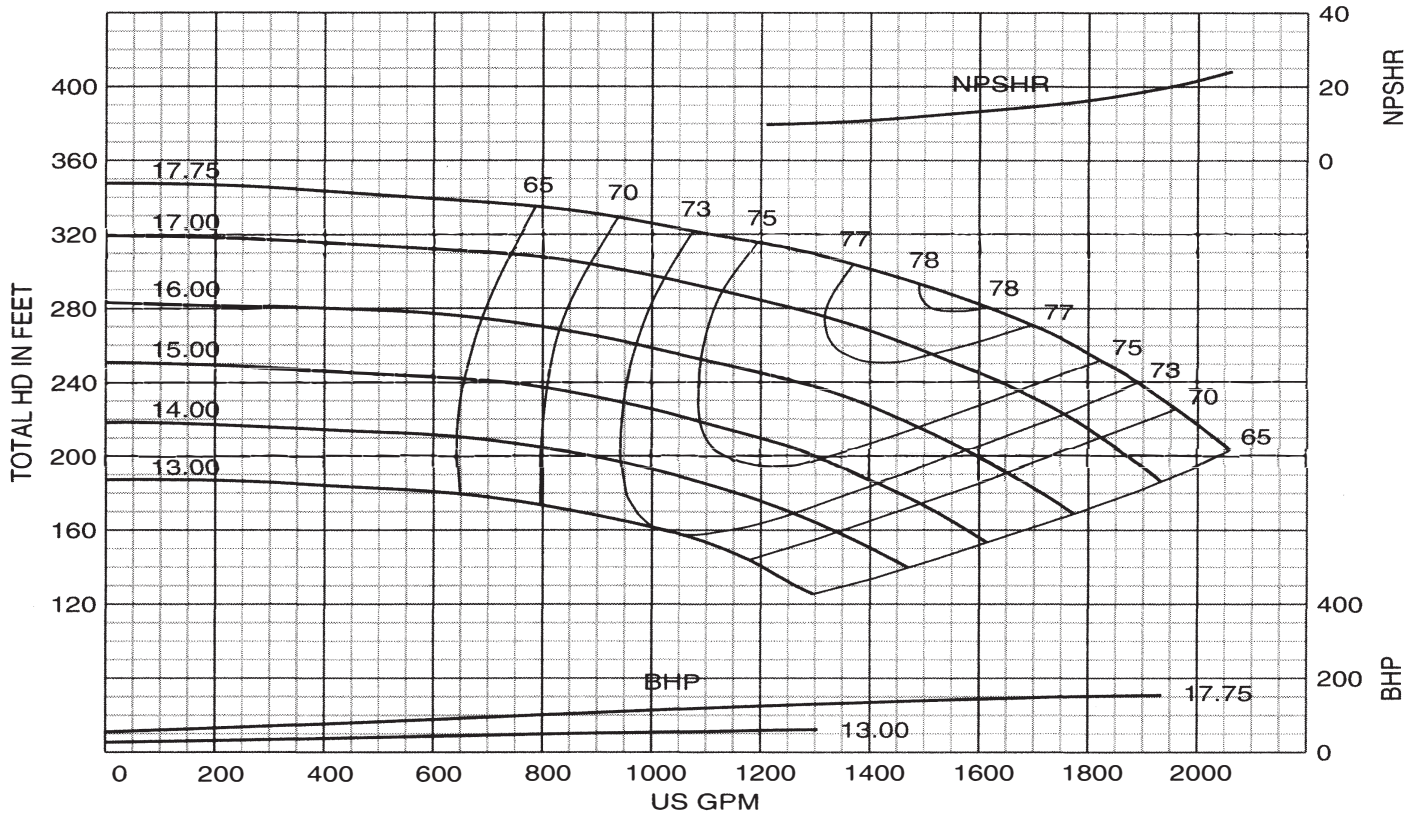

# Performance Curve - 6" 2824A

IMPELLER: J6L1A1 SUCTION: 10" INLET: 60.30 in<sup>2</sup>

RPM: 1785 SOLIDS: 1.13"

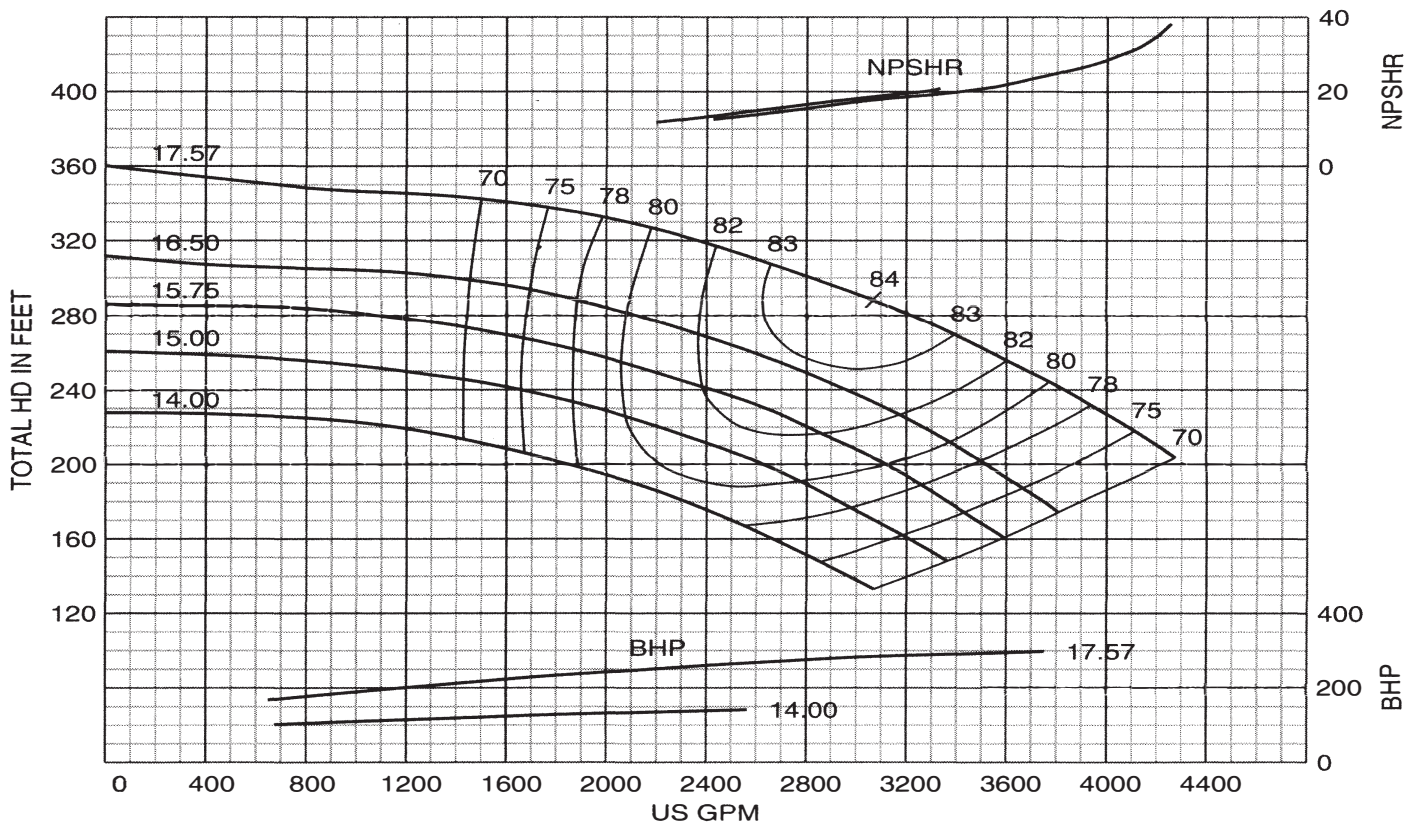

# Performance Curve - 6" 2824C

RPM: 1785 SOLIDS: .88"

IMPELLER: J6L1C1 SUCTION: 10" INLET: 58.50 in<sup>2</sup>

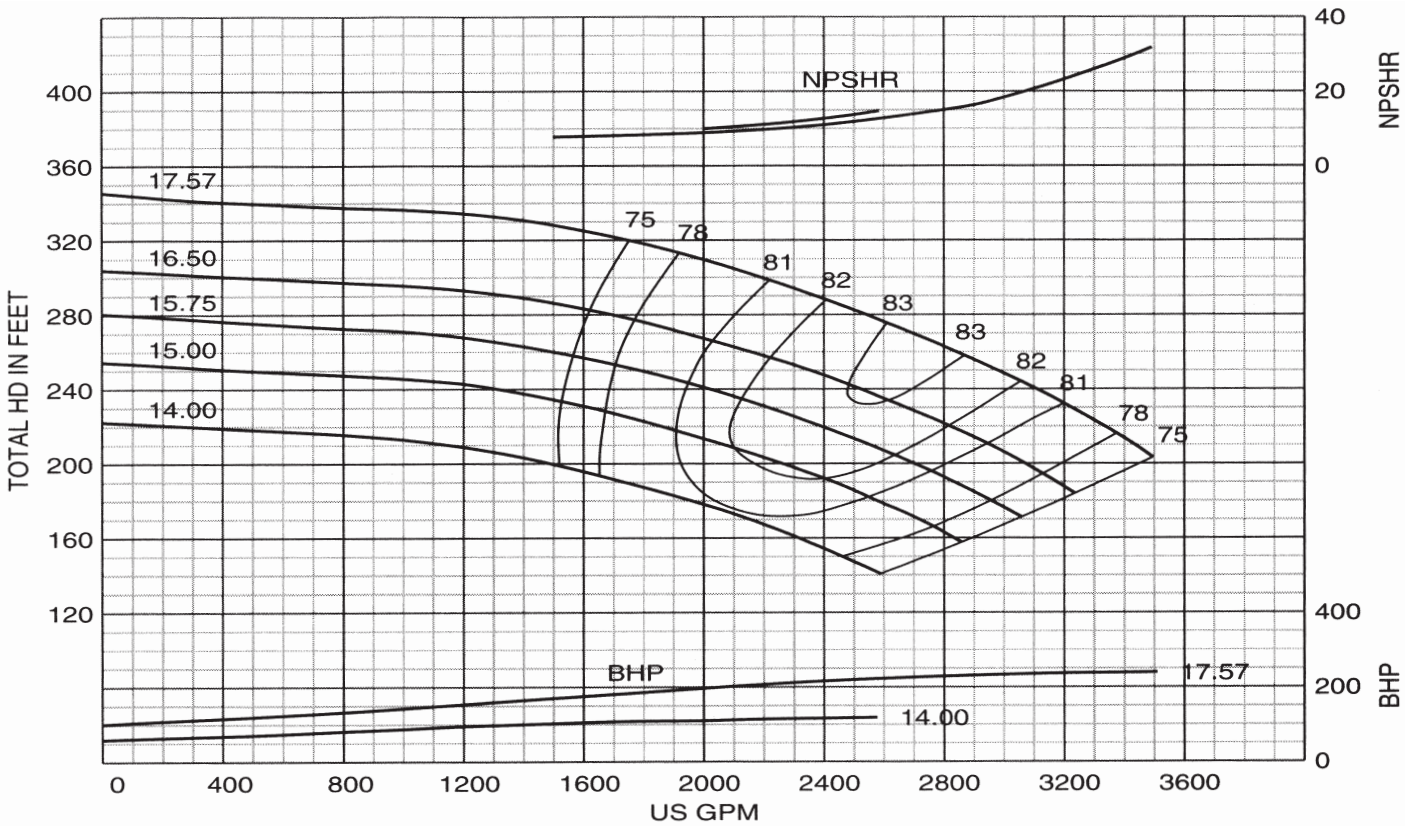

# Performance Curve - 8" 2824A

RPM: 1785 SOLIDS: 1.12"

IMPELLER: J8L1A1 SUCTION: 12" INLET: 81.28 in<sup>2</sup>

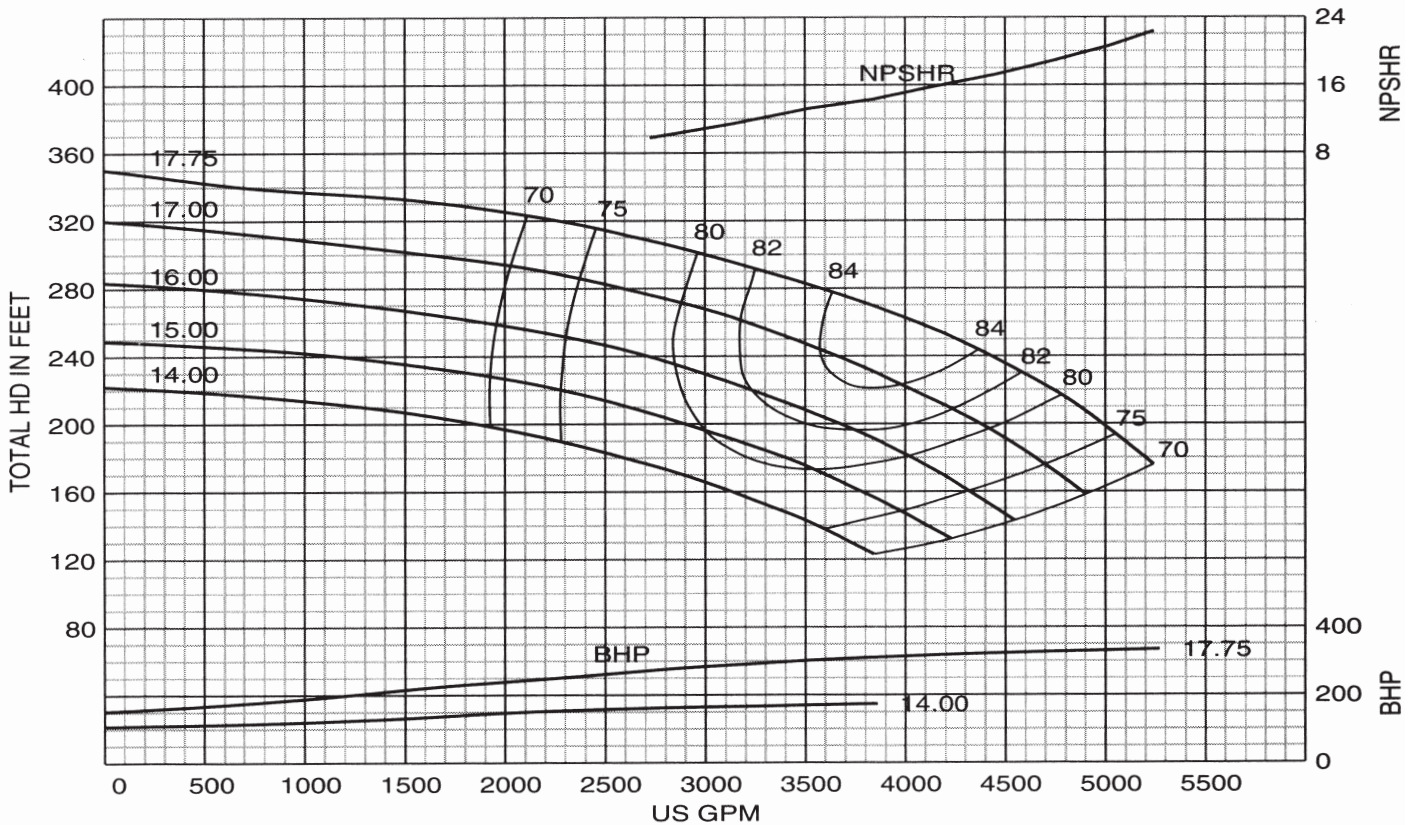

# Performance Curve - 10" 2824A

IMPELLER: J10L1A1 SUCTION: 14" INLET: 128.4 in<sup>2</sup>

RPM: 1785 SOLIDS: 1.41"

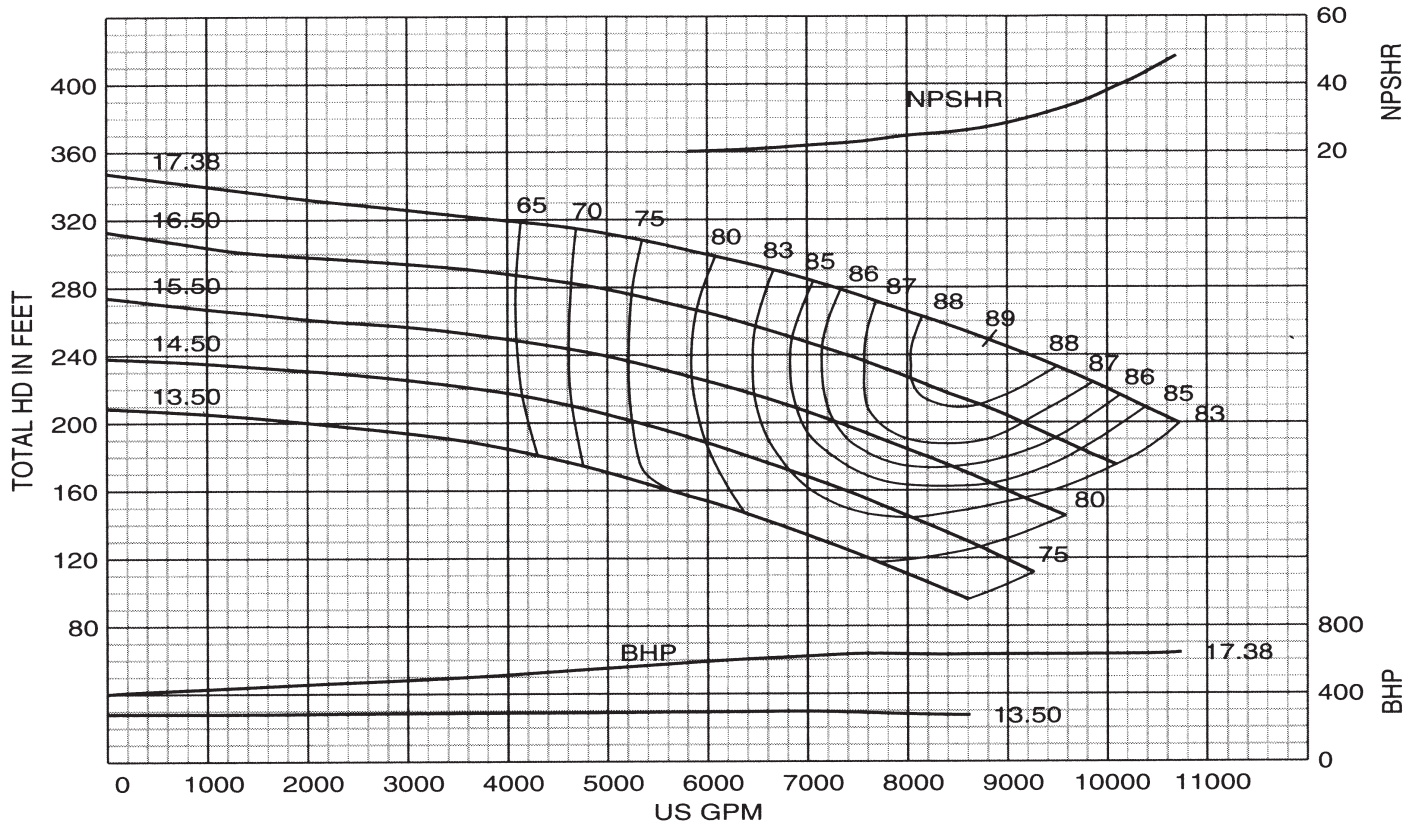

# Performance Curve - 6" 2825A

IMPELLER: J6M1A1 SUCTION: 10" INLET: 62.64 in<sup>2</sup>

RPM: 1785 SOLIDS: .88"

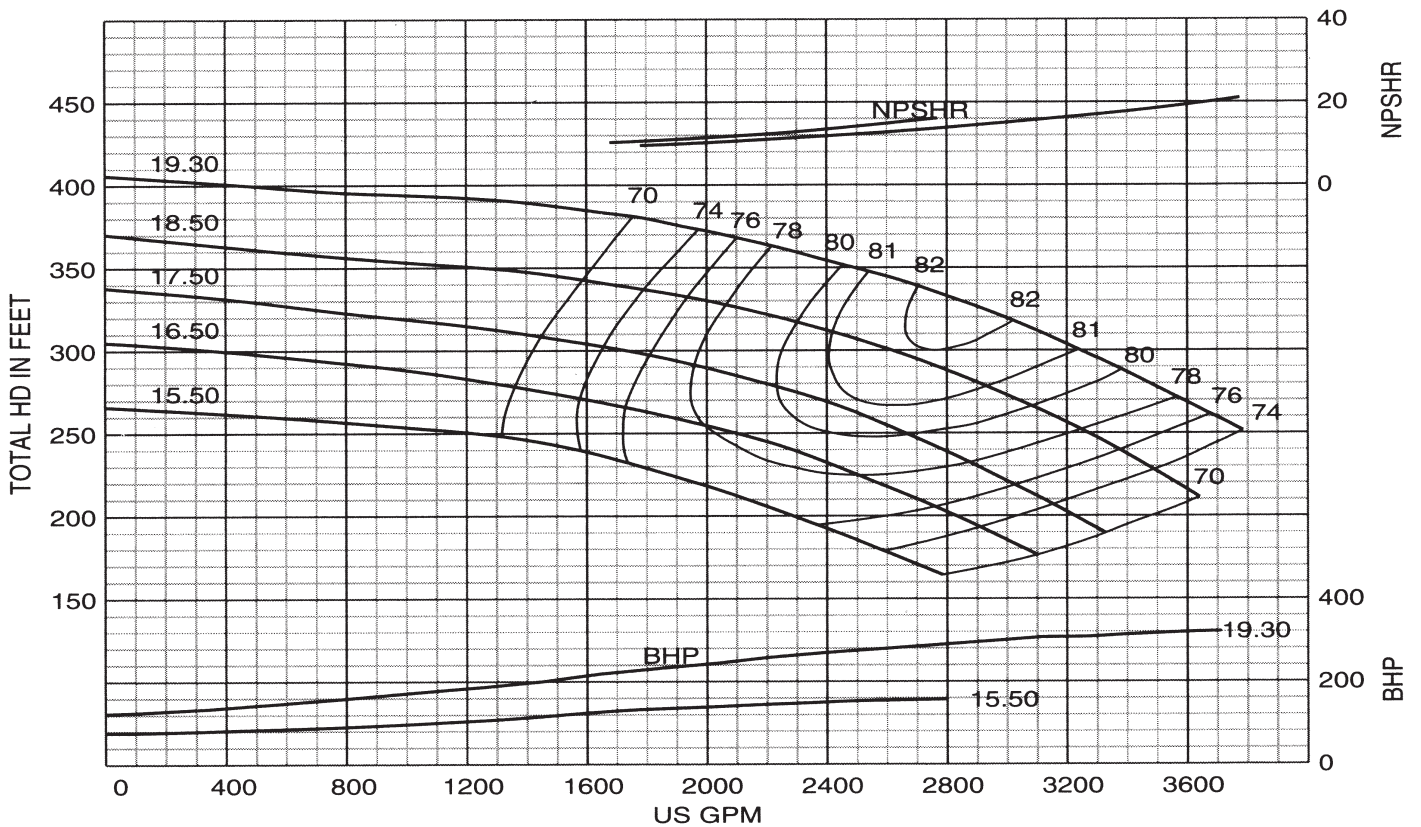

# Performance Curve - 10" 2825A

RPM: 1785 SOLIDS: 2.0"

IMPELLER: J10M1C1 SUCTION: 16" INLET: 160 in<sup>2</sup>

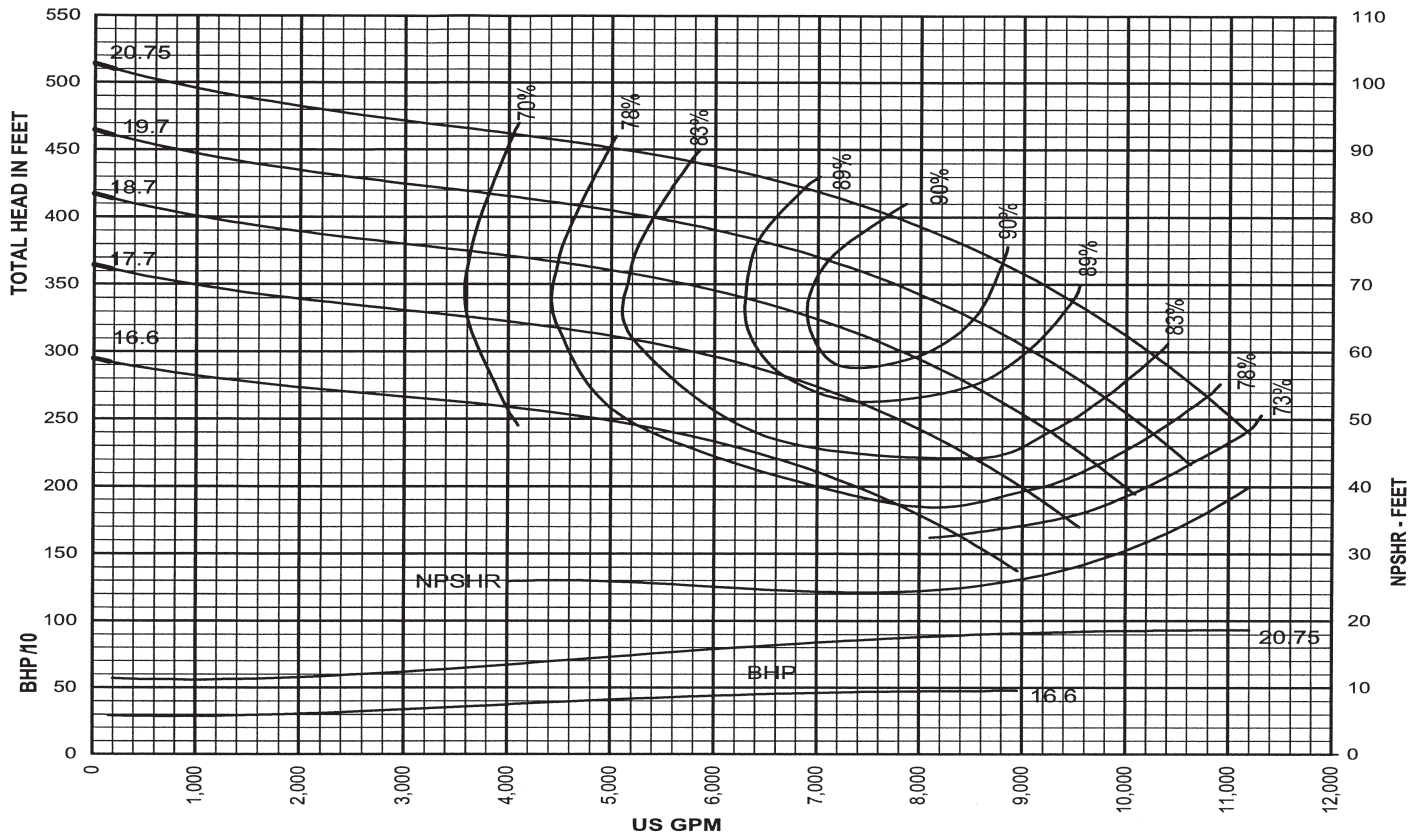

# Performance Curve - 10" 2825C

RPM: 1785 SOLIDS: 1.12"

IMPELLER: J10M1A1 SUCTION: 12" INLET: 97.62 in<sup>2</sup>

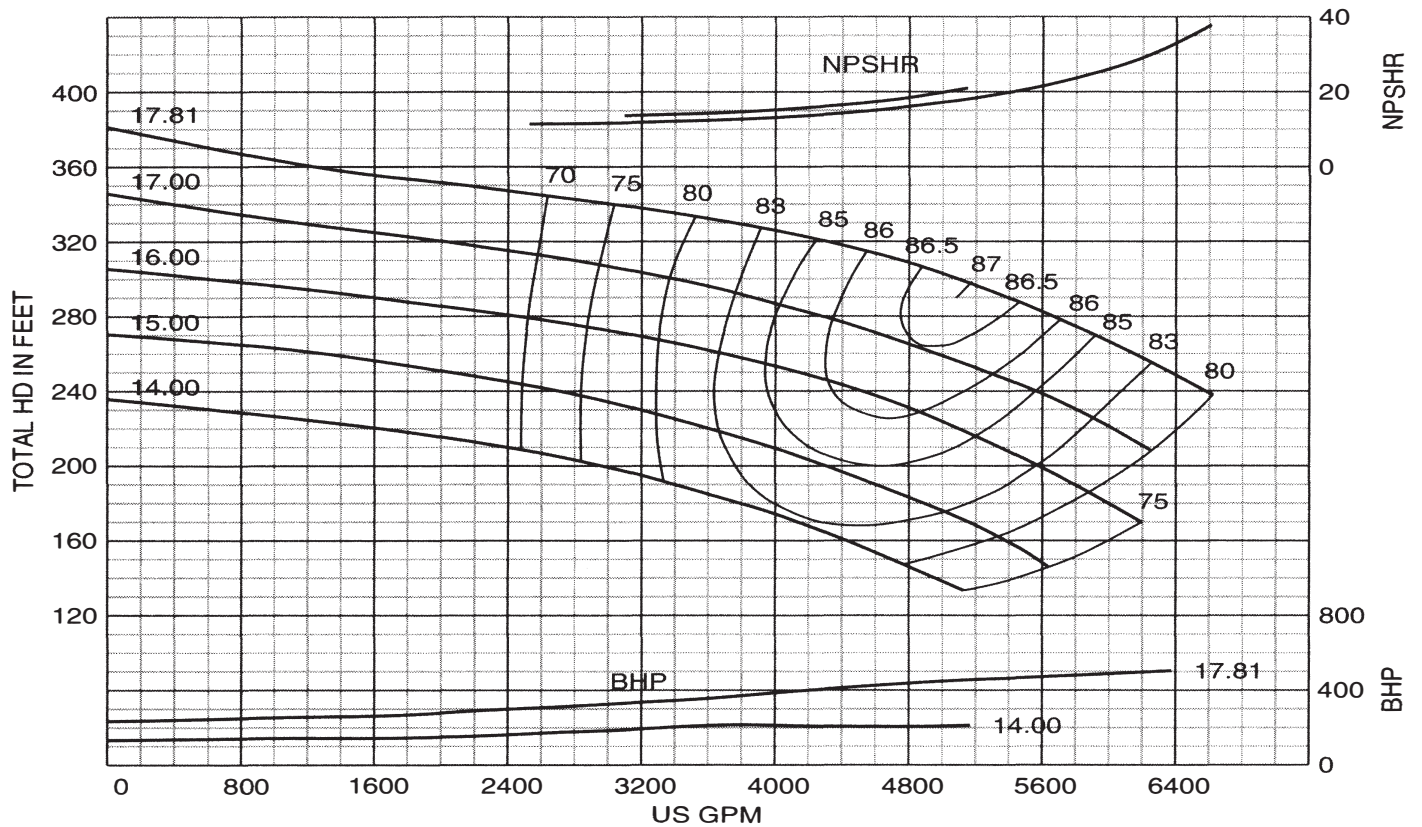



# Performance Curve - 2" 2873A

IMPELLER: J2B1B1 SUCTION: 4" INLET: 8.64 in<sup>2</sup>

RPM: 1750 SOLIDS: .38"

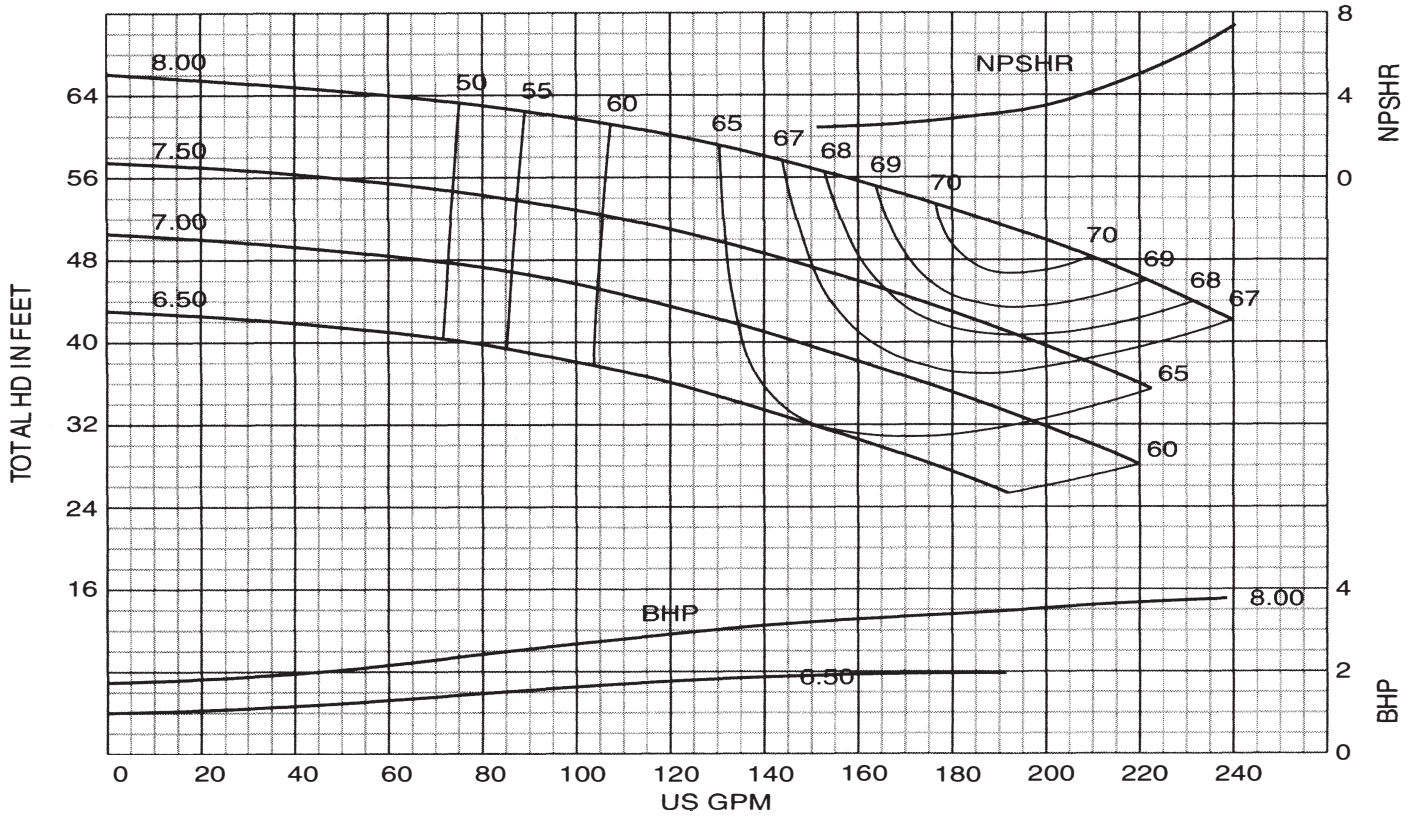

# Performance Curve - 4" 2873A

IMPELLER: J4B1A1 SUCTION: 6" INLET: 15.90 in<sup>2</sup>

RPM: 1760 SOLIDS: .50"

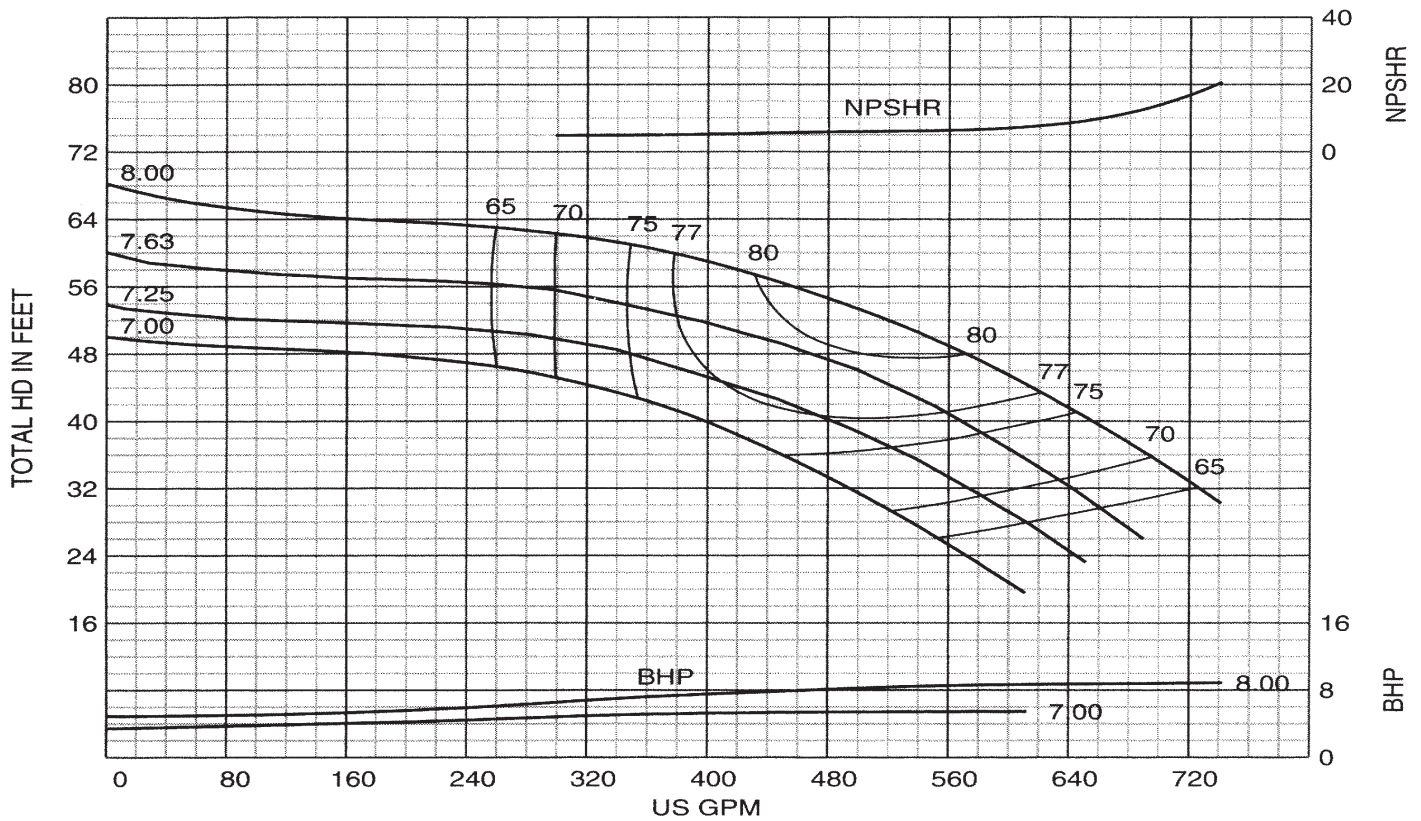

# Performance Curve - 3" 2874A

RPM: 1760 SOLIDS: .62"

IMPELLER: J3C1A1 SUCTION: 5" INLET: 17.00 in<sup>2</sup>

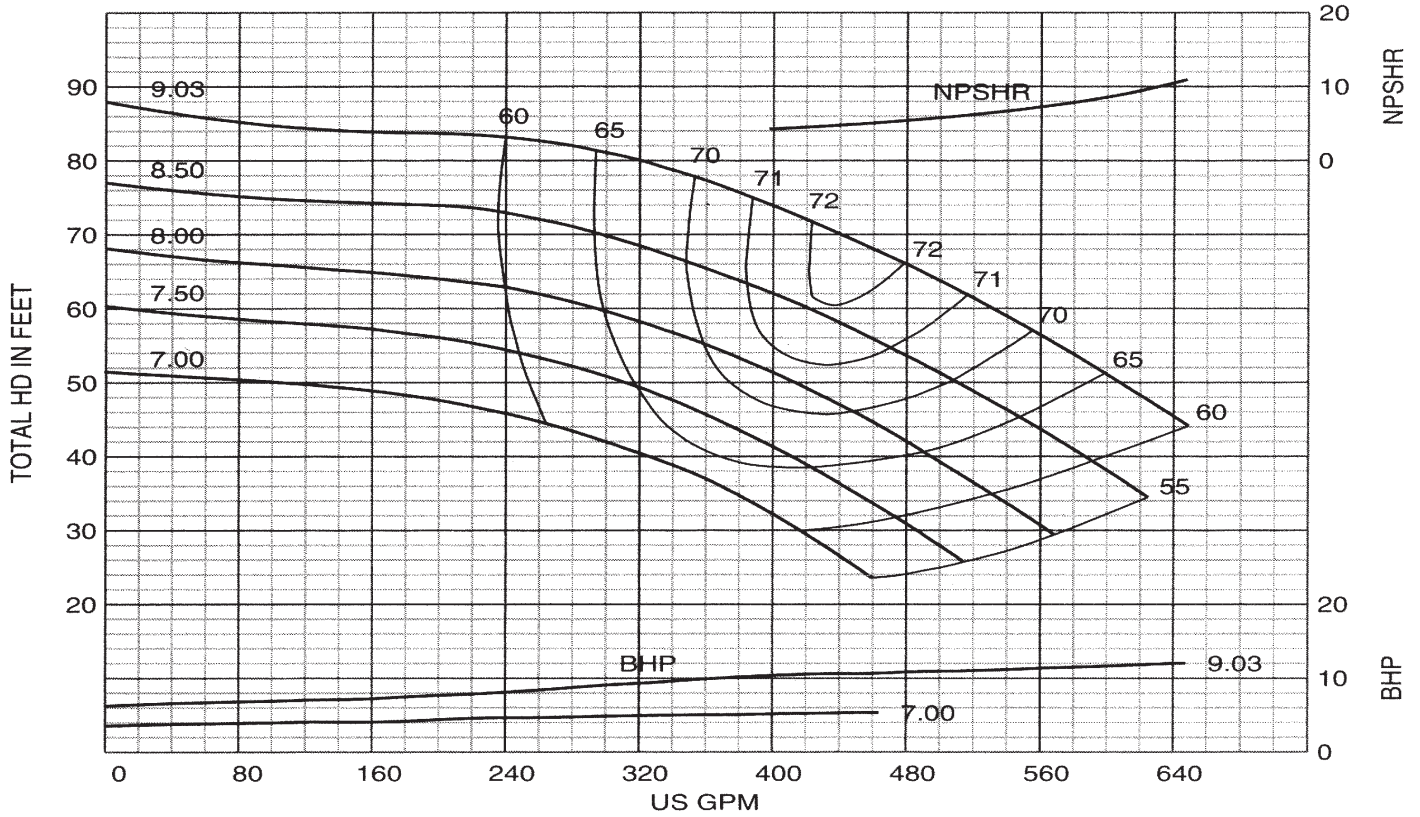

# Performance Curve - 3" 2874C

RPM: 1760 SOLIDS: .50"

IMPELLER: J3C1C1 SUCTION: 5" INLET: 16.16 in<sup>2</sup>

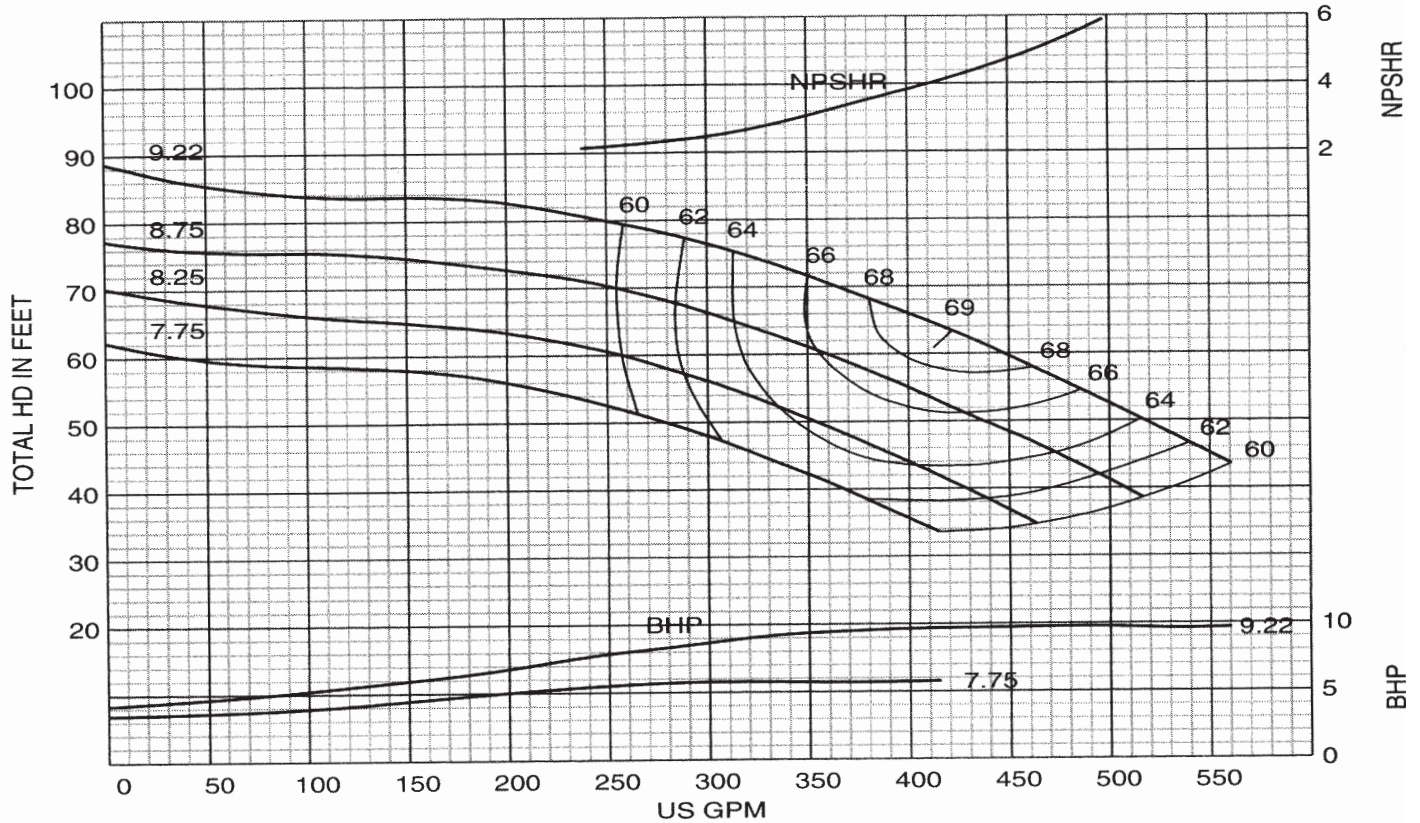

# Performance Curve - 4" 2874C

IMPELLER: J4C1C1 SUCTION: 6" INLET: 25.08in<sup>2</sup>

RPM: 1765 SOLIDS: .50"

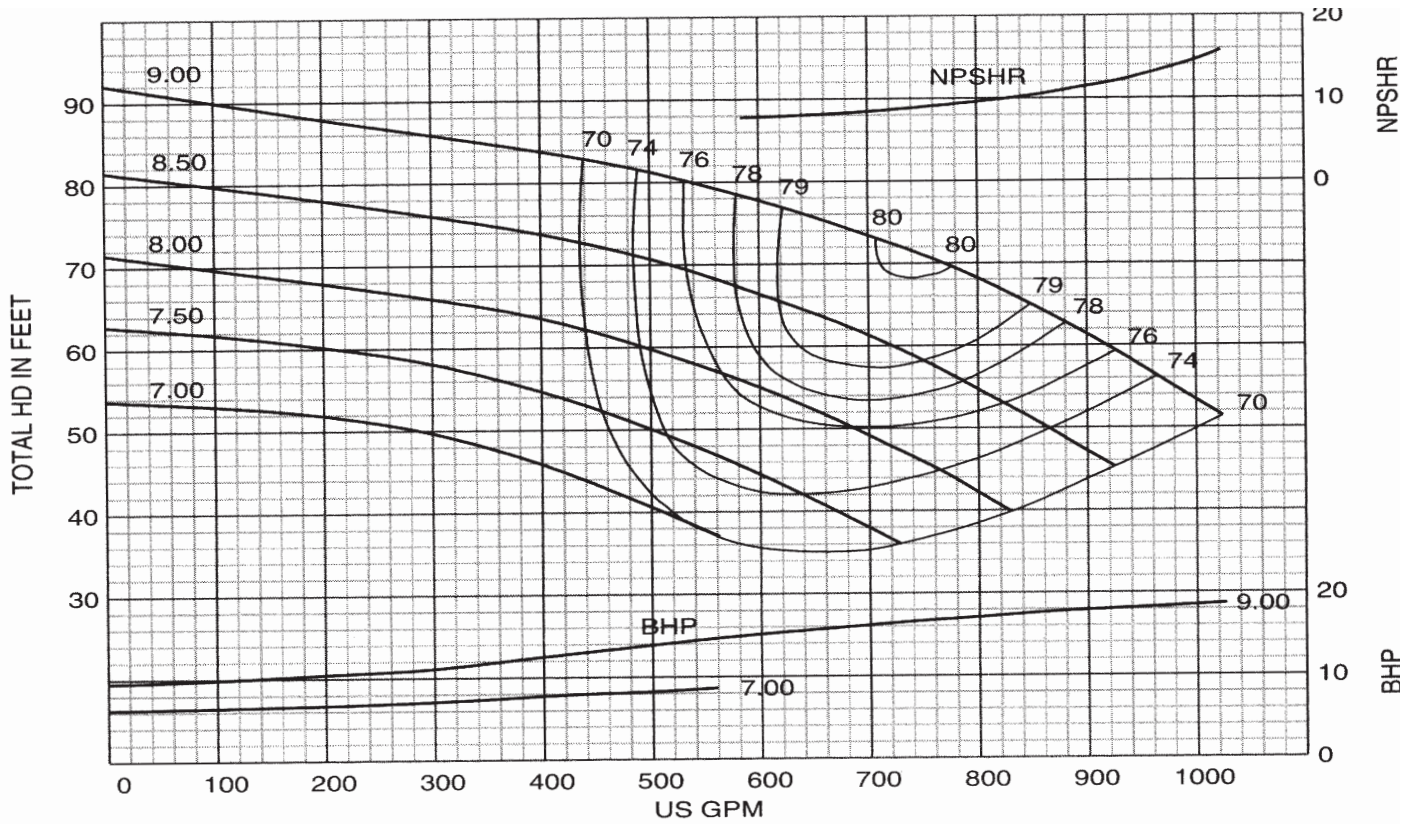

# Performance Curve - 5" 2874A

IMPELLER: J5C1A1 SUCTION: 8" INLET: 34.24 in<sup>2</sup>

RPM: 1770 SOLIDS: .86"

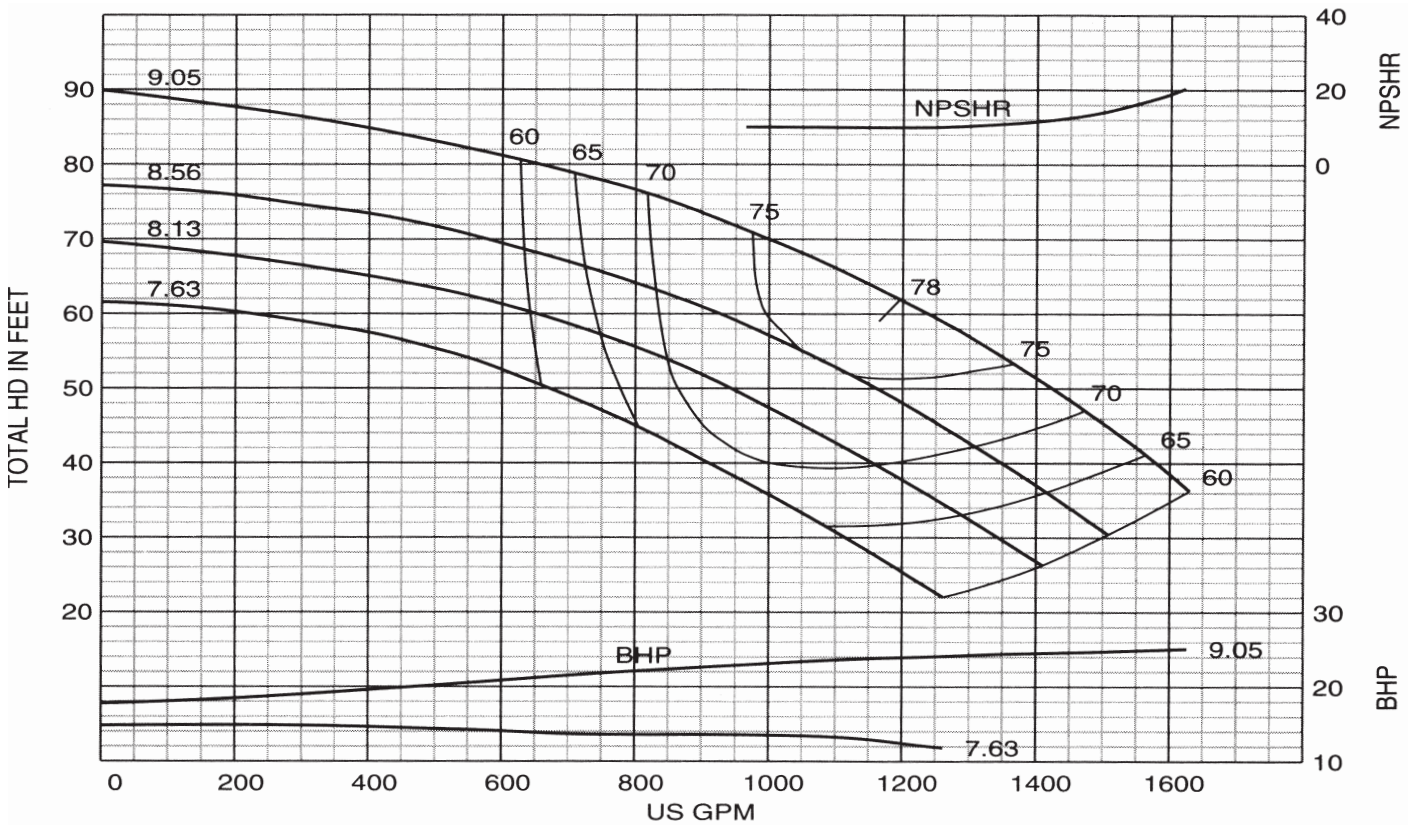

# Performance Curve - 4" 2876A

IMPELLER: J4E1A1 SUCTION: 6" INLET: 25.02 in<sup>2</sup>

RPM: 1770 SOLIDS: .50"

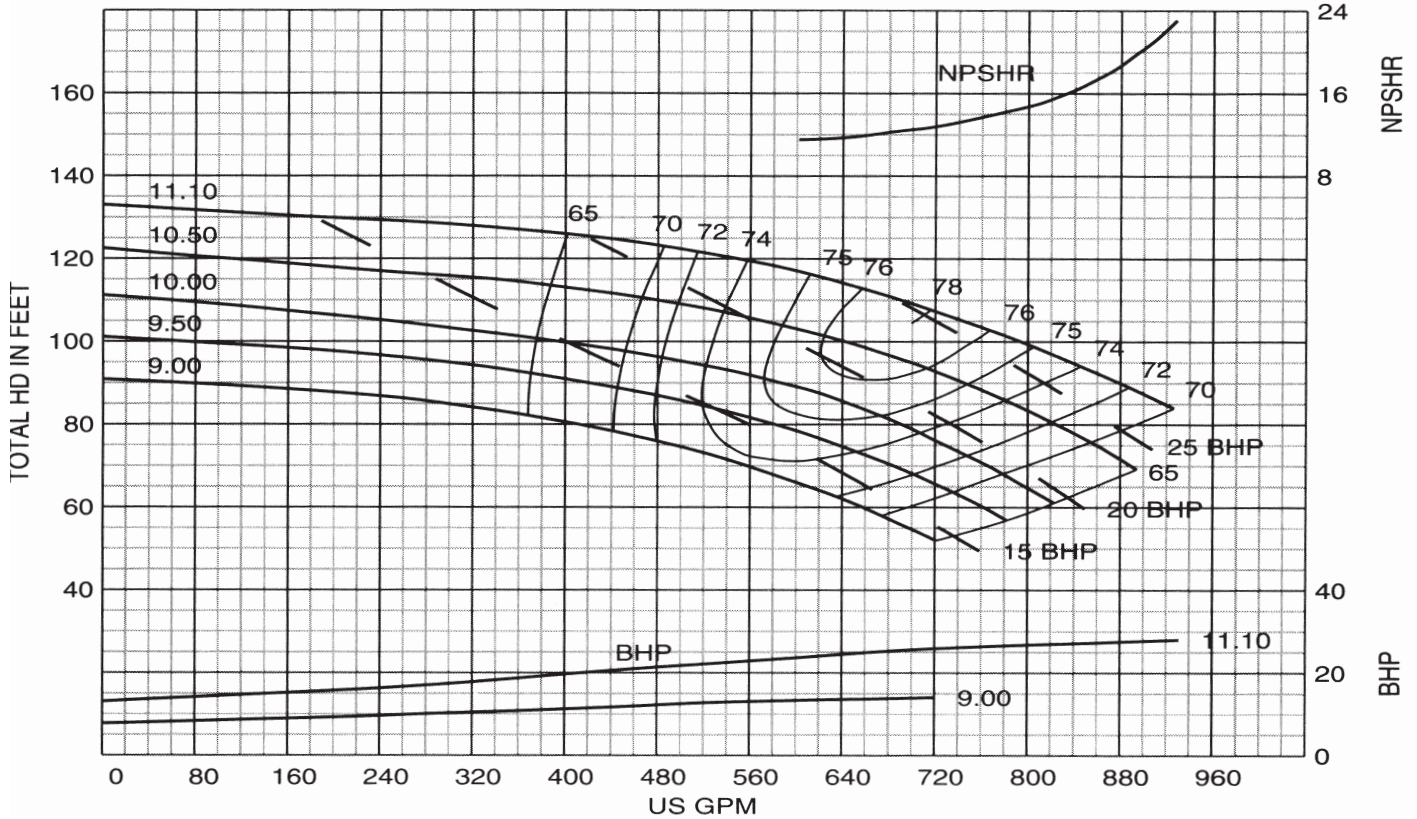

# Performance Curve - 4" 2876C

IMPELLER: J4E1C1 SUCTION: 6" INLET: 25.02 in<sup>2</sup>

RPM: 1765 SOLIDS: .60"

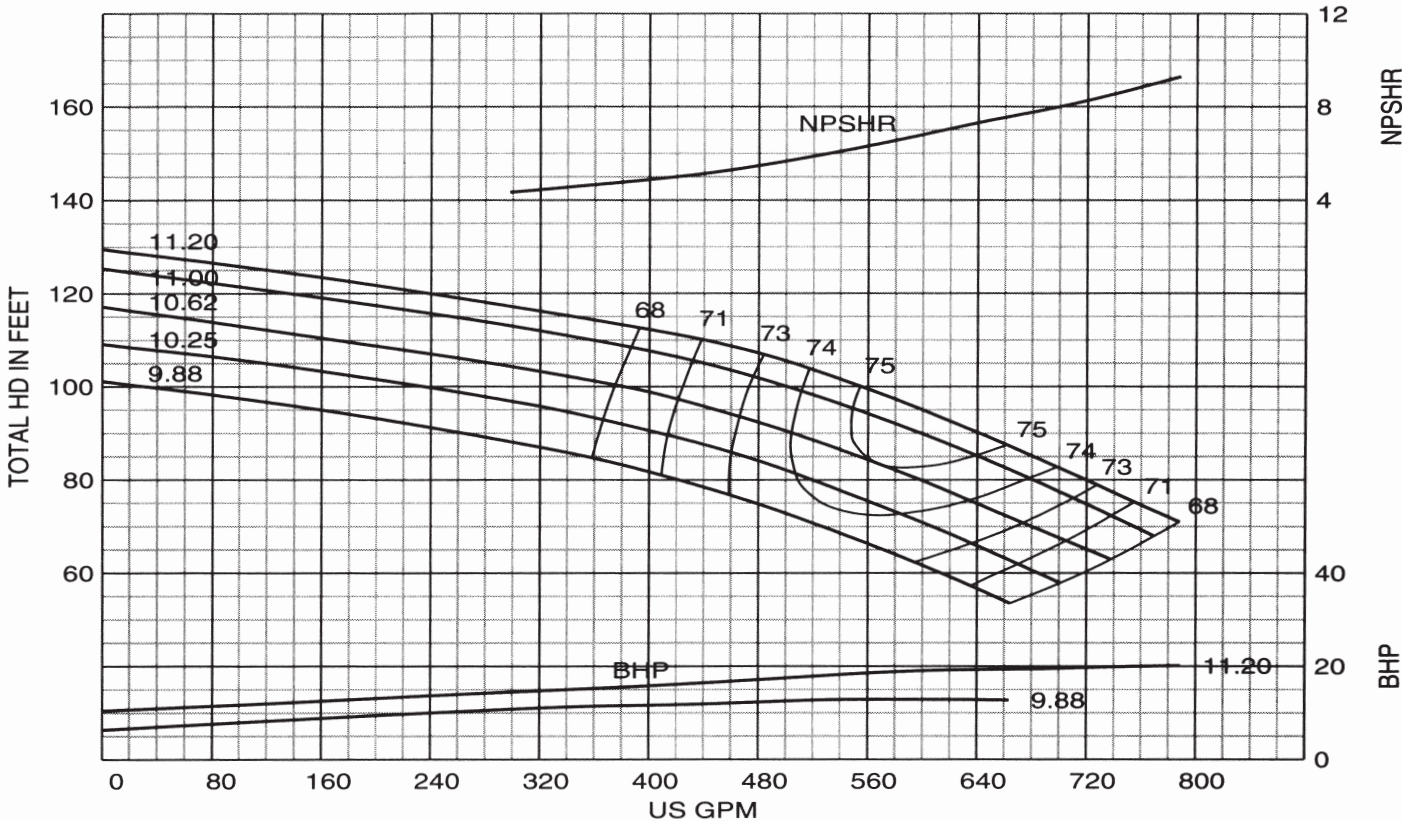

# Performance Curve - 5" 2876A

IMPELLER: J5E1A1 SUCTION: 8" INLET: 42.12 in<sup>2</sup>

RPM: 1780 SOLIDS: .75"

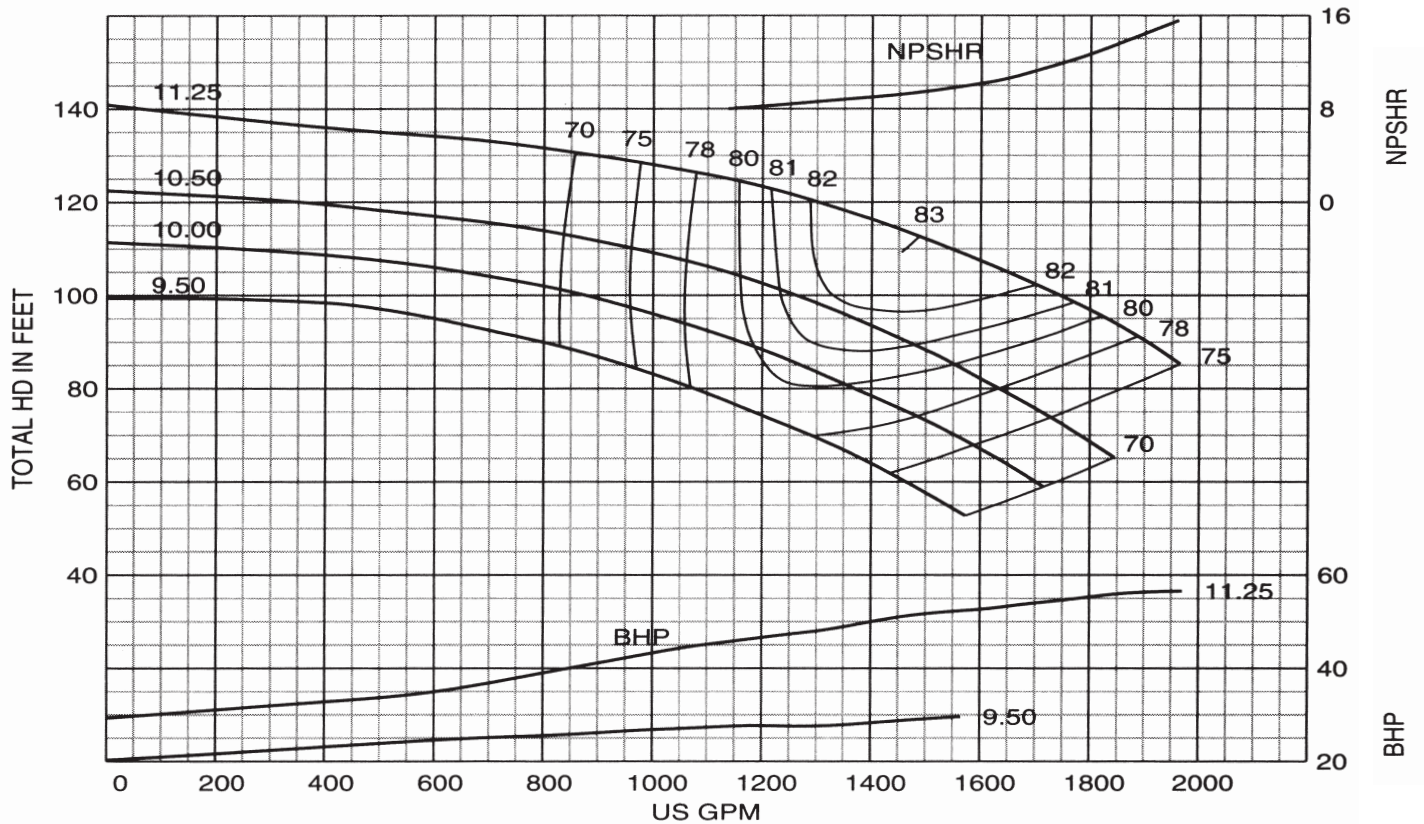

# Performance Curve - 6" 2821A

IMPELLER: J6C1A1 SUCTION: 8" INLET: 44.4 in<sup>2</sup>

RPM: 1170 SOLIDS: .88"

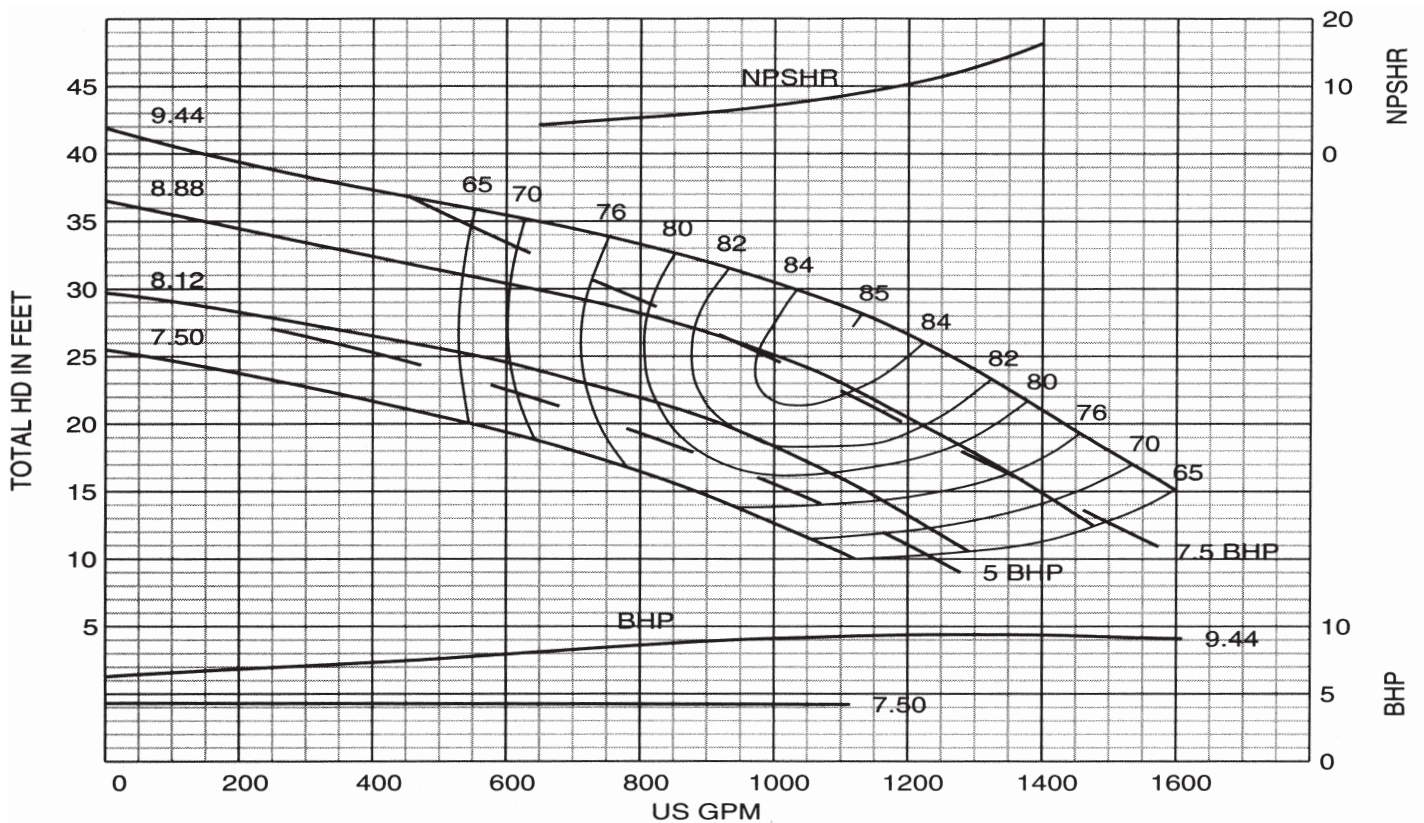

# Performance Curve - 8" 2821A

RPM: 1175 SOLIDS: .88"

IMPELLER: J8C1A3 SUCTION: 10" INLET: 64.54 in<sup>2</sup>

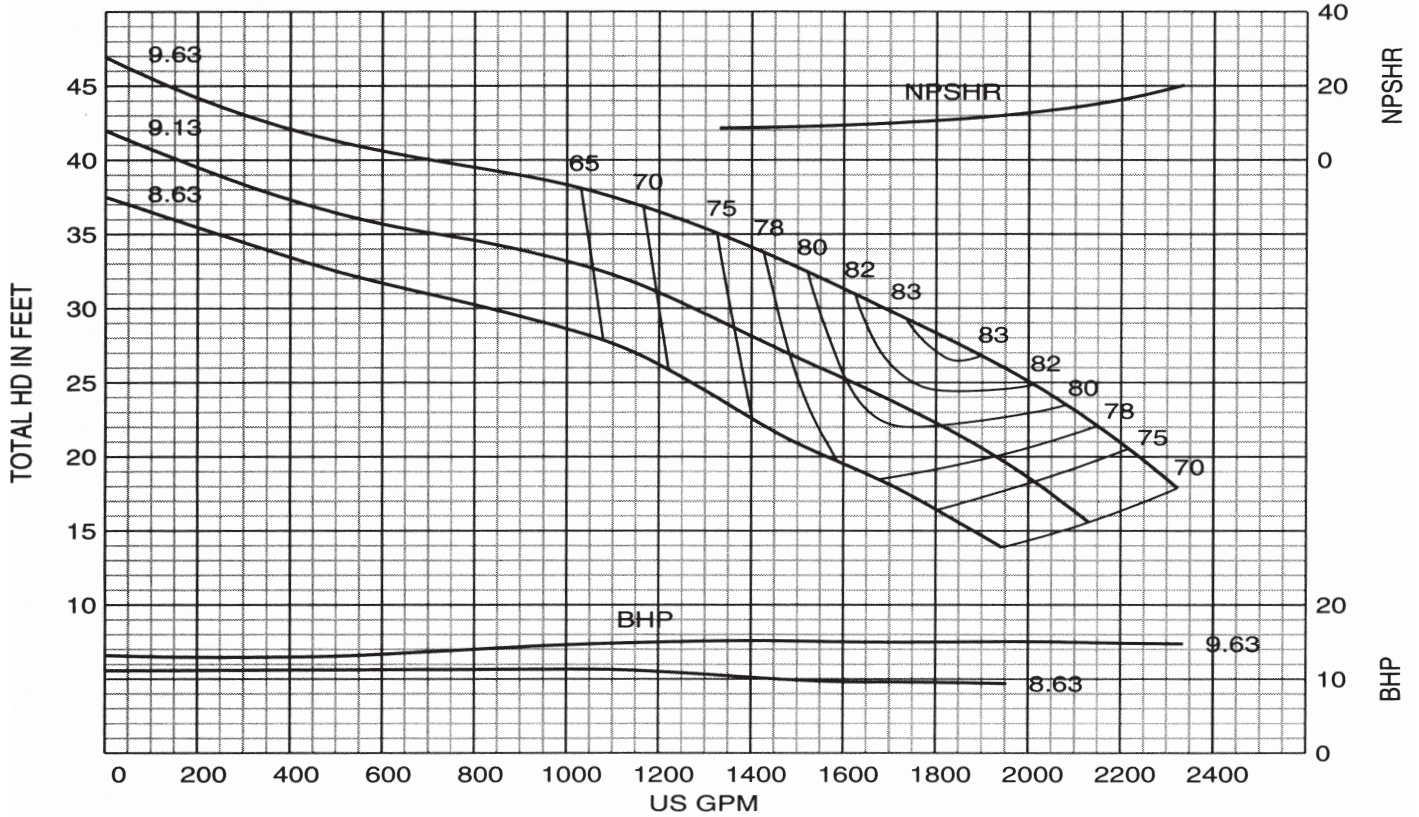

# Performance Curve - 6" 2822A

RPM: 1175 SOLIDS: 1.06"

IMPELLER: J6E1A1 SUCTION: 10" INLET: 48.06 in<sup>2</sup>

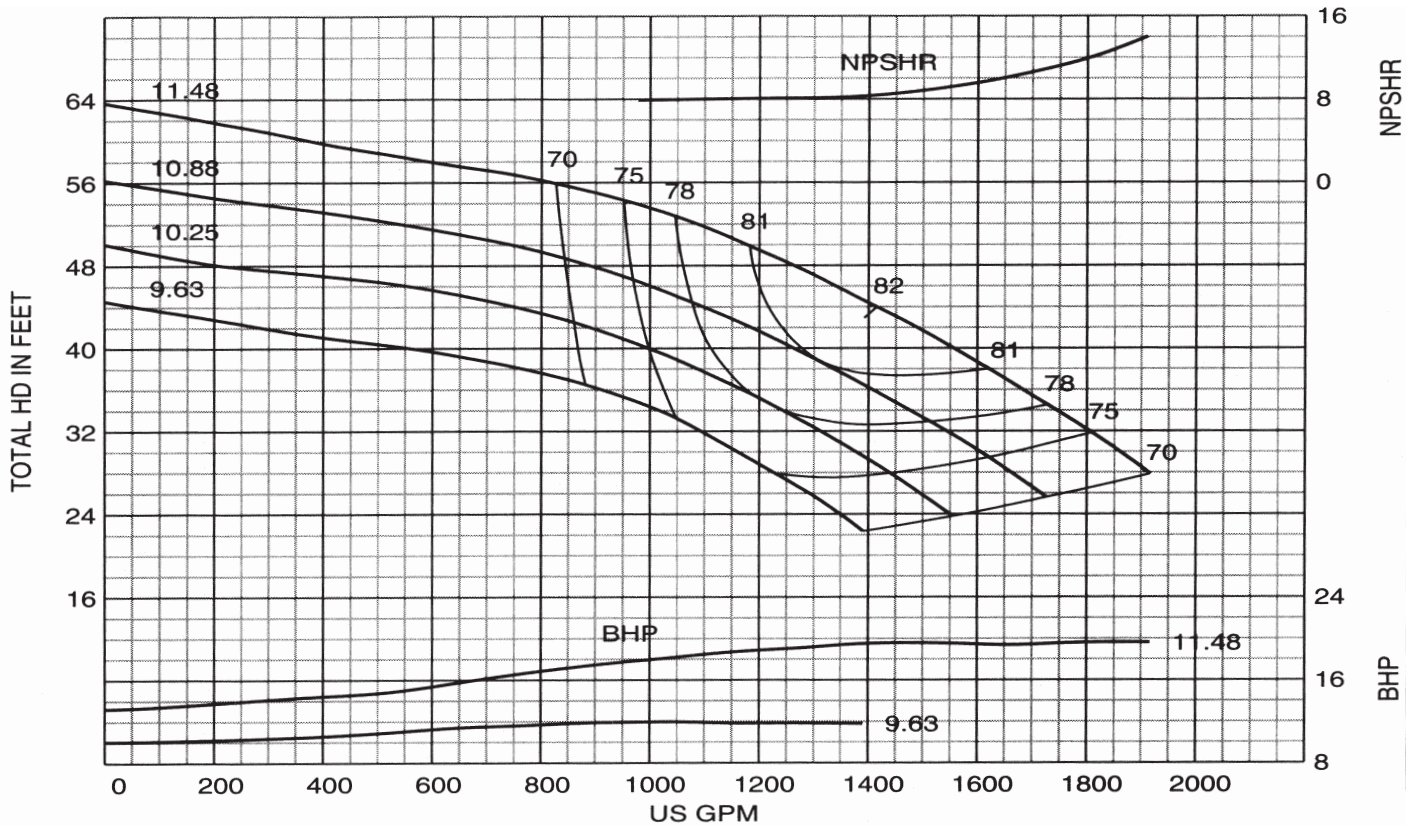

# Performance Curve – 6" 2822X

IMPELLER: J6E1F SUCTION: 6" INLET: 25.52 in<sup>2</sup>

RPM: 1180 SOLIDS: .437"

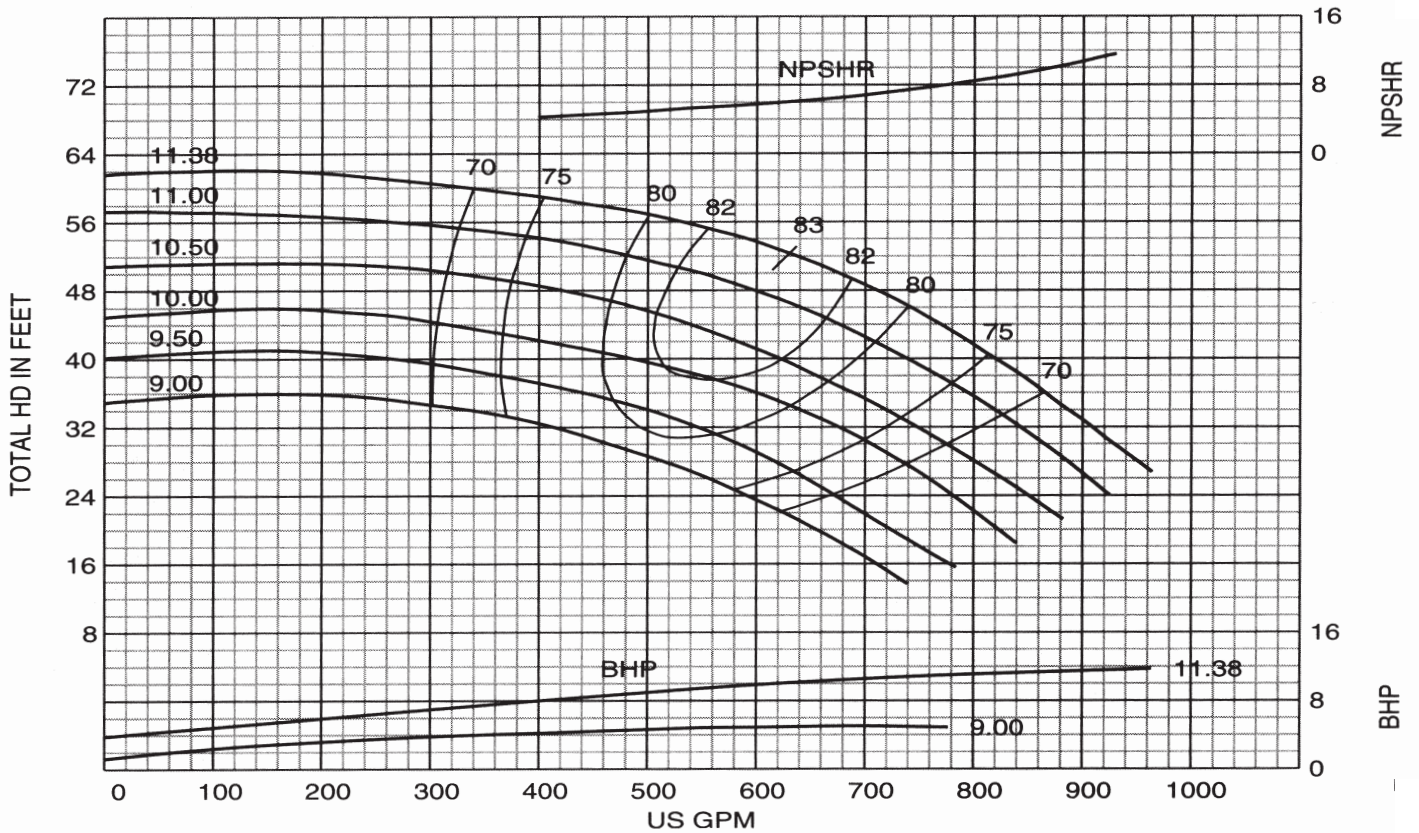

# Performance Curve – 8" 2822A

IMPELLER: J8E1A1 SUCTION: 10" INLET: 57.5 in<sup>2</sup>

RPM: 1180 SOLIDS: 1.25"

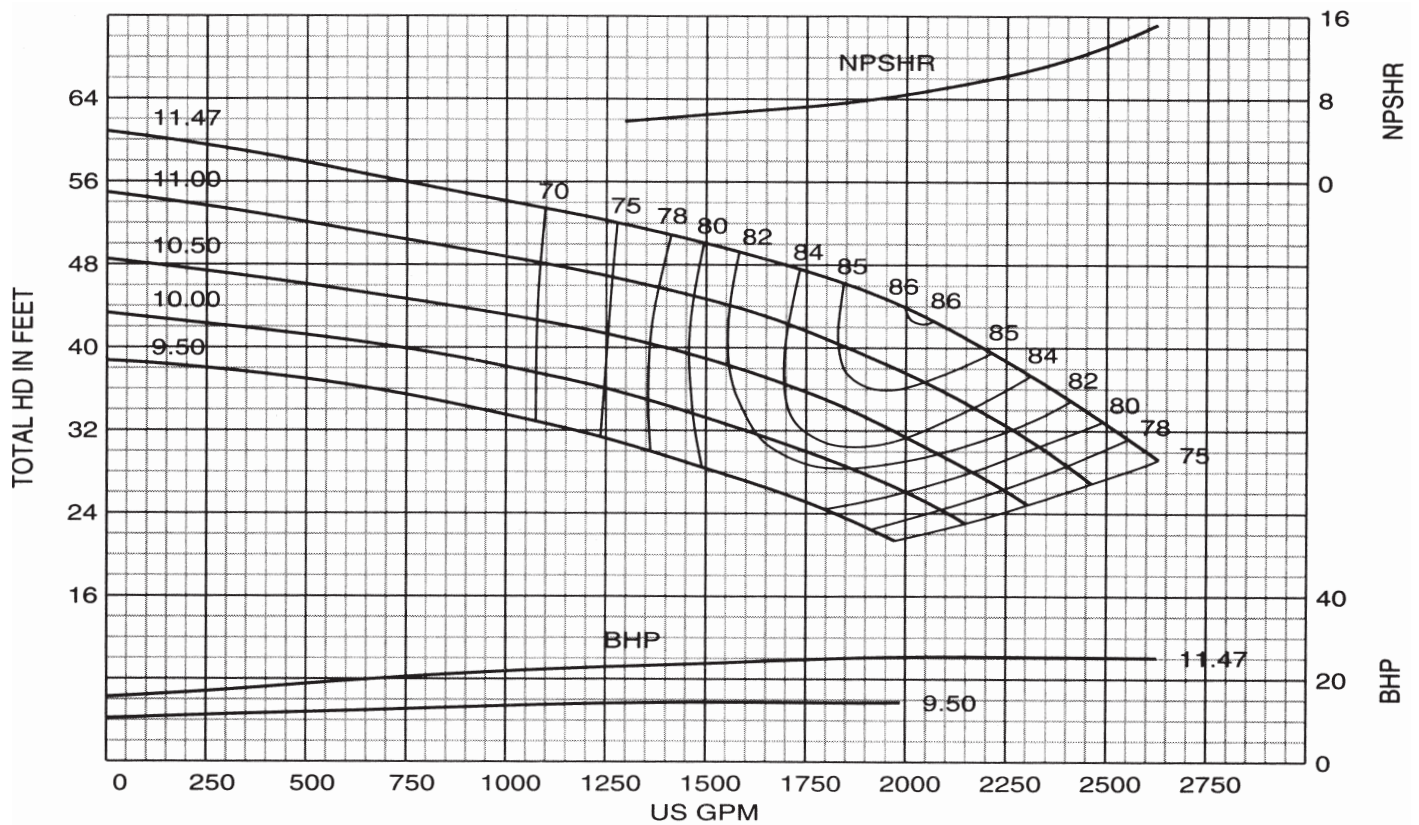

# Performance Curve - 10" 2822A

RPM: 1185 SOLIDS: 1.00"

IMPELLER: J10E1A3 SUCTION: 14" INLET: 103.40 in<sup>2</sup>

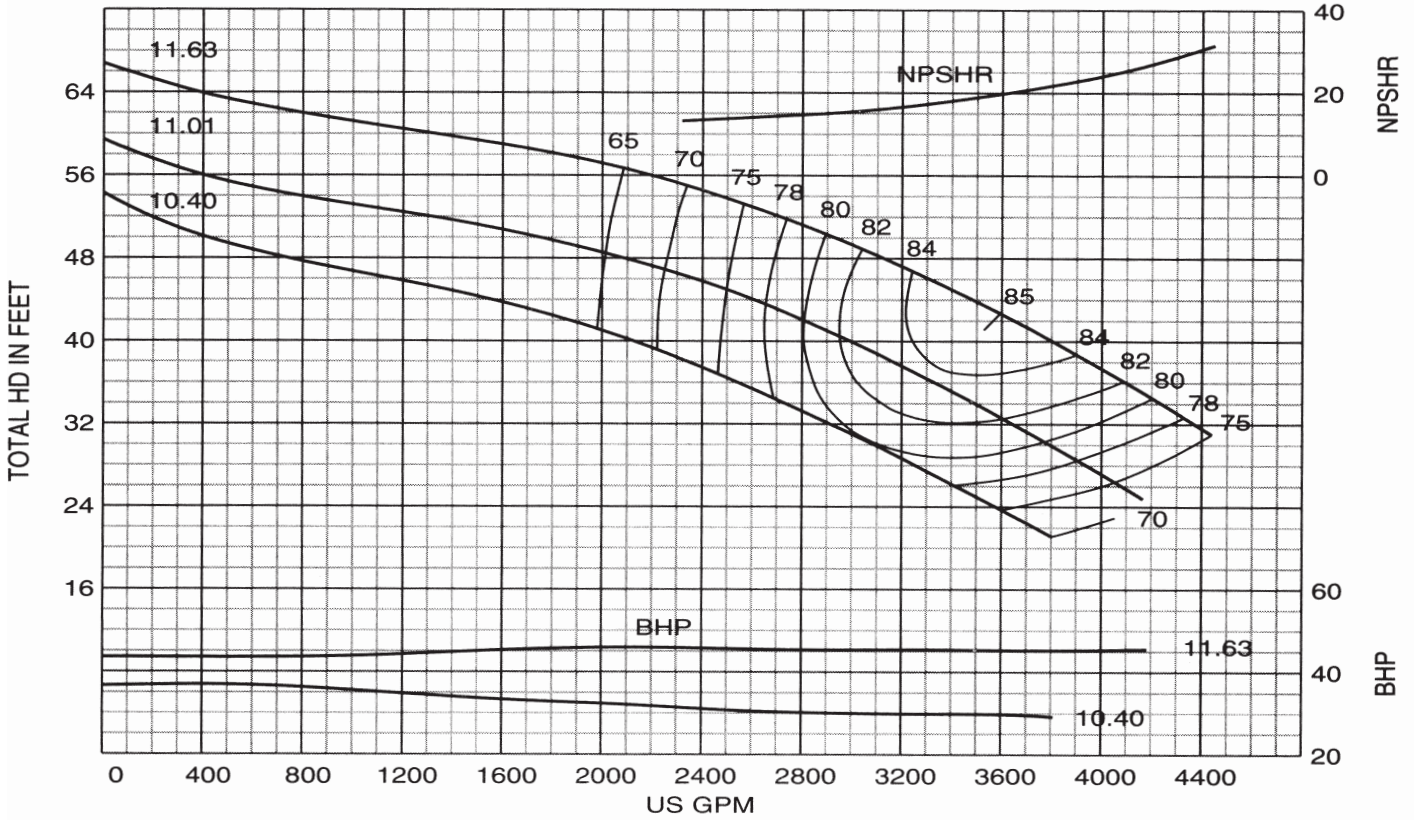

# Performance Curve - 3" 2823A

RPM: 1775 SOLIDS: .54"

IMPELLER: J3H1A1 SUCTION: 5" INLET: 16.4 in<sup>2</sup>

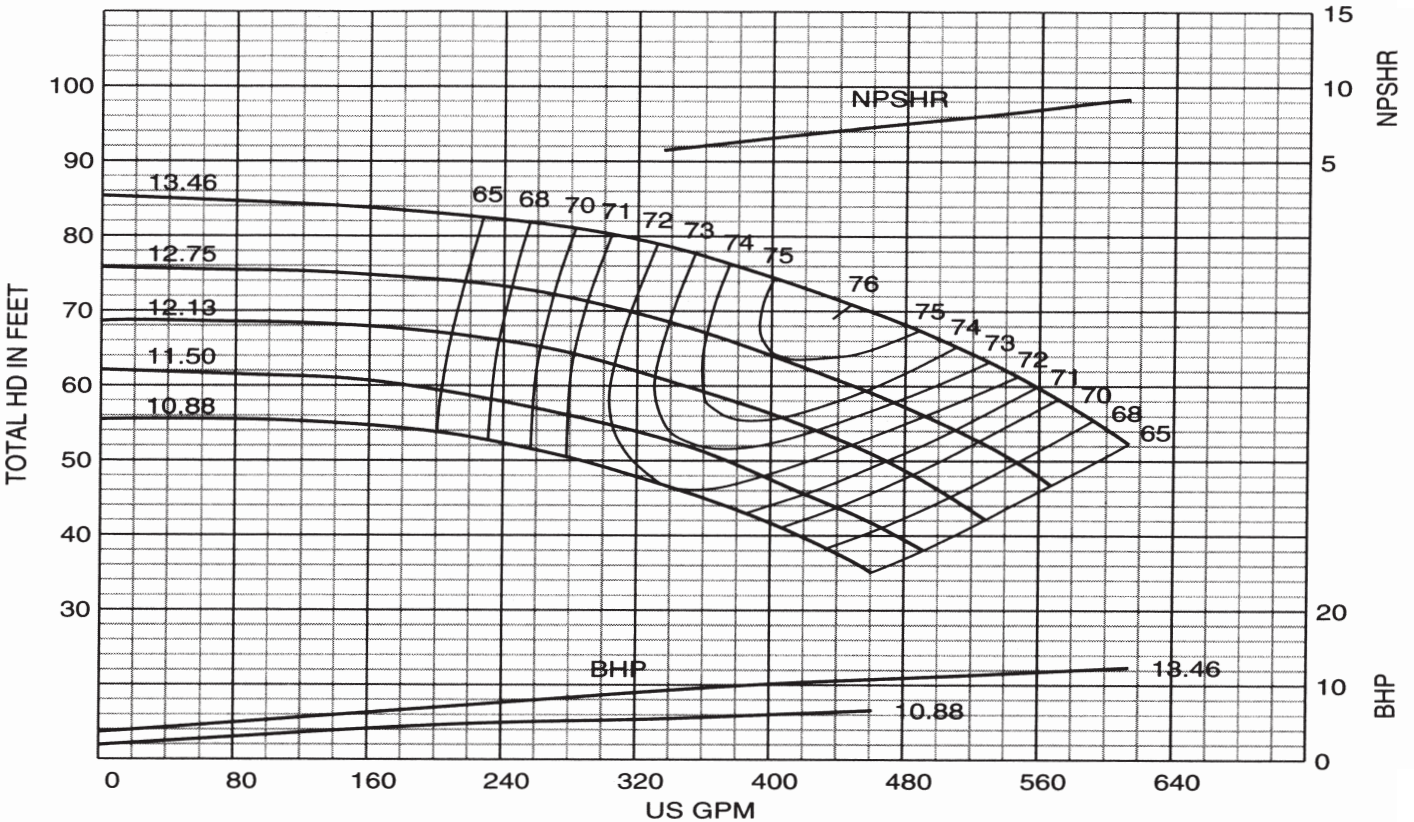



# Performance Curve - 4" 2823C

IMPELLER: J4H1C1 SUCTION: 6" INLET: 24.72 in<sup>2</sup>

RPM: 1175 SOLIDS: .63"

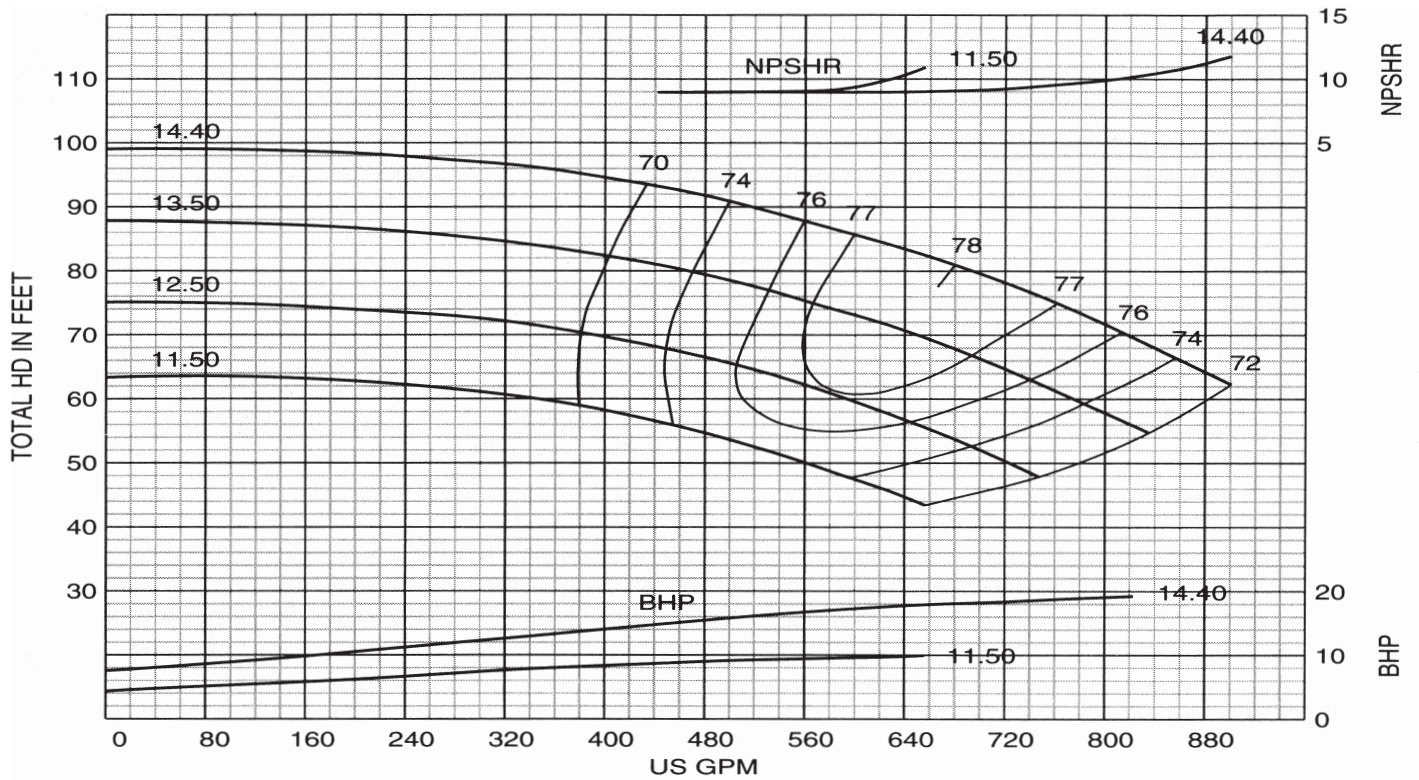

# Performance Curve - 5" 2823A

IMPELLER: J5H1A1 SUCTION: 8" INLET: 35.80 in<sup>2</sup>

RPM: 1180 SOLIDS: .95"

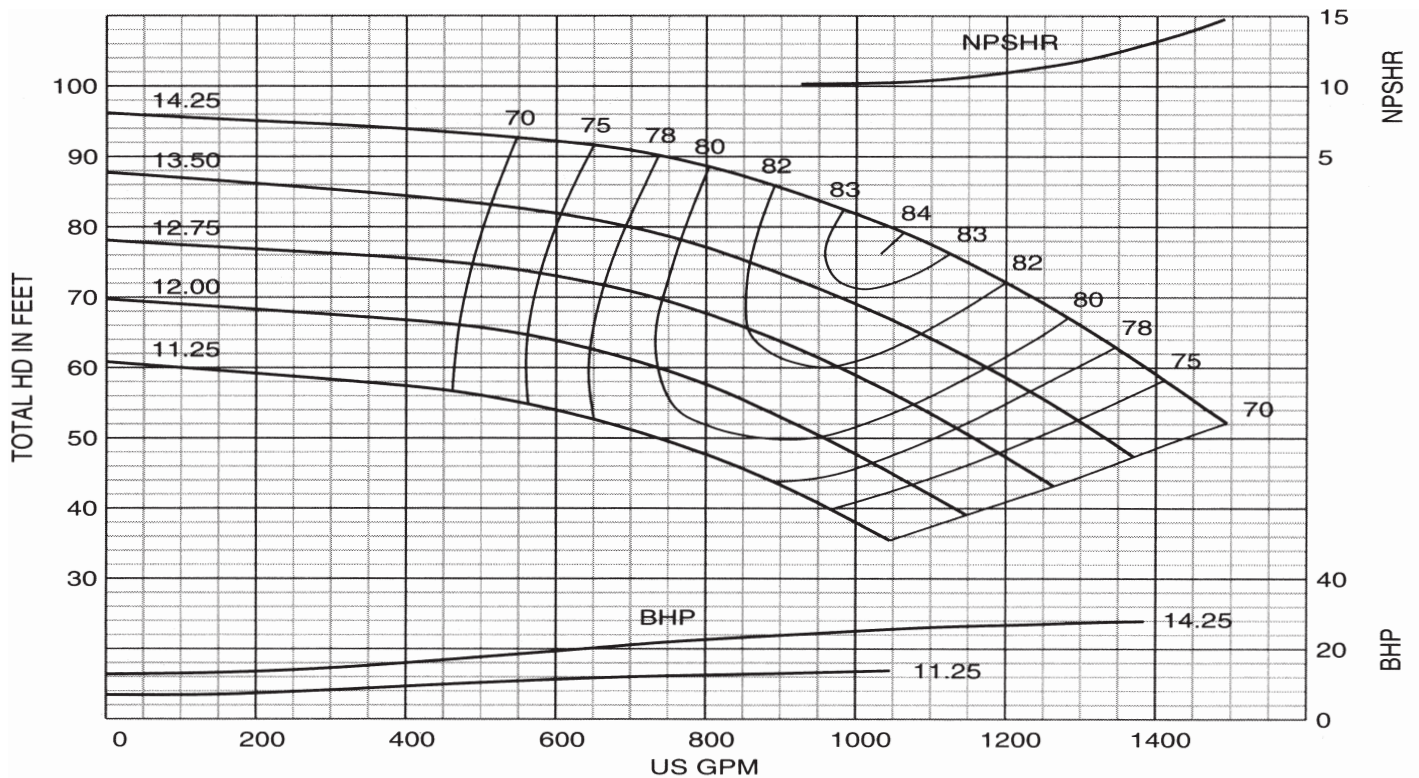

# Performance Curve - 6" 2823A

RPM: 1185 SOLIDS: 1.00"

IMPELLER: J6H1A1 SUCTION: 10" INLET: 55.50 in<sup>2</sup>

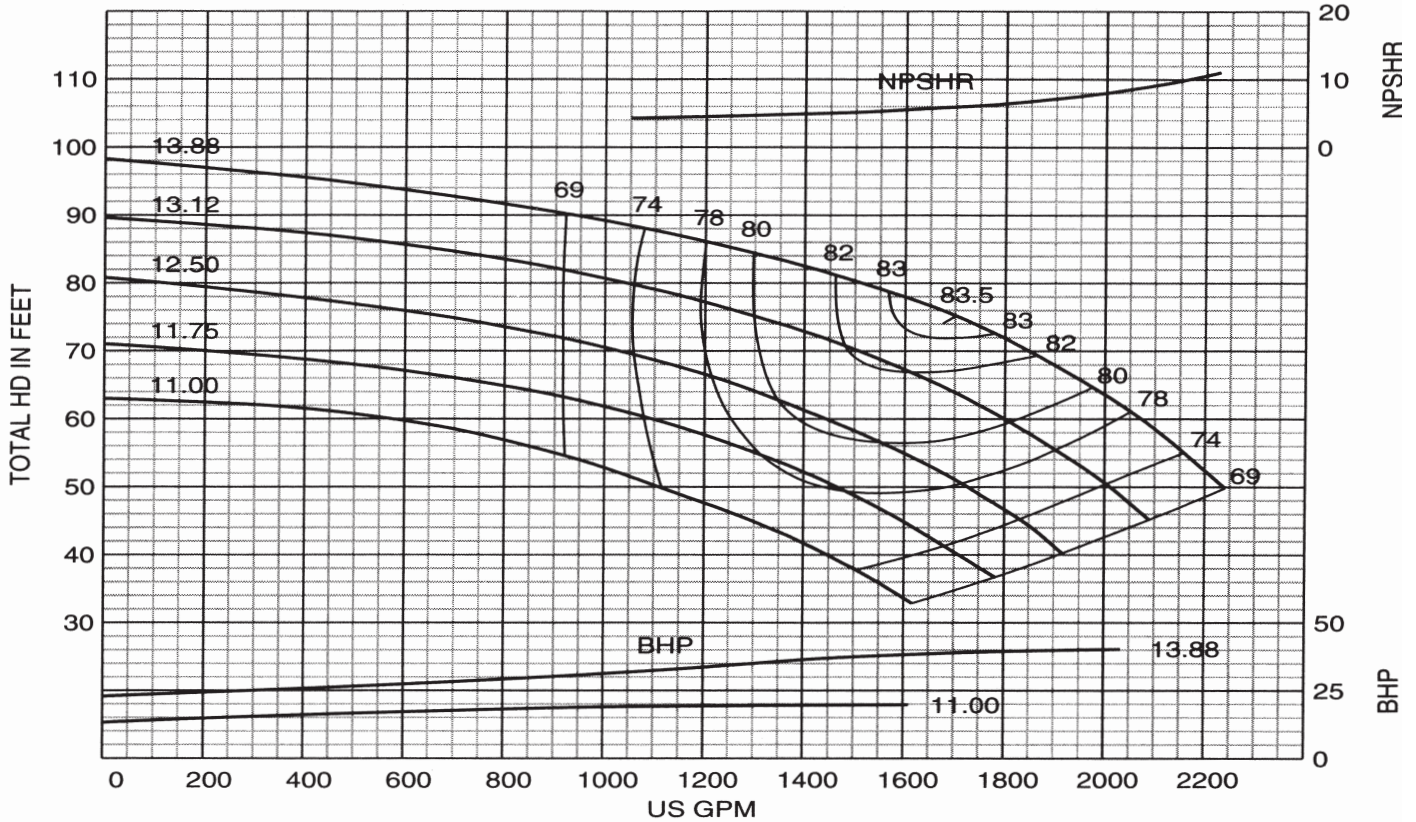

# Performance Curve - 6" 2823C

RPM: 1180 SOLIDS: 1.00"

IMPELLER: J6H1C1 SUCTION: 10" INLET: 53.46 in<sup>2</sup>

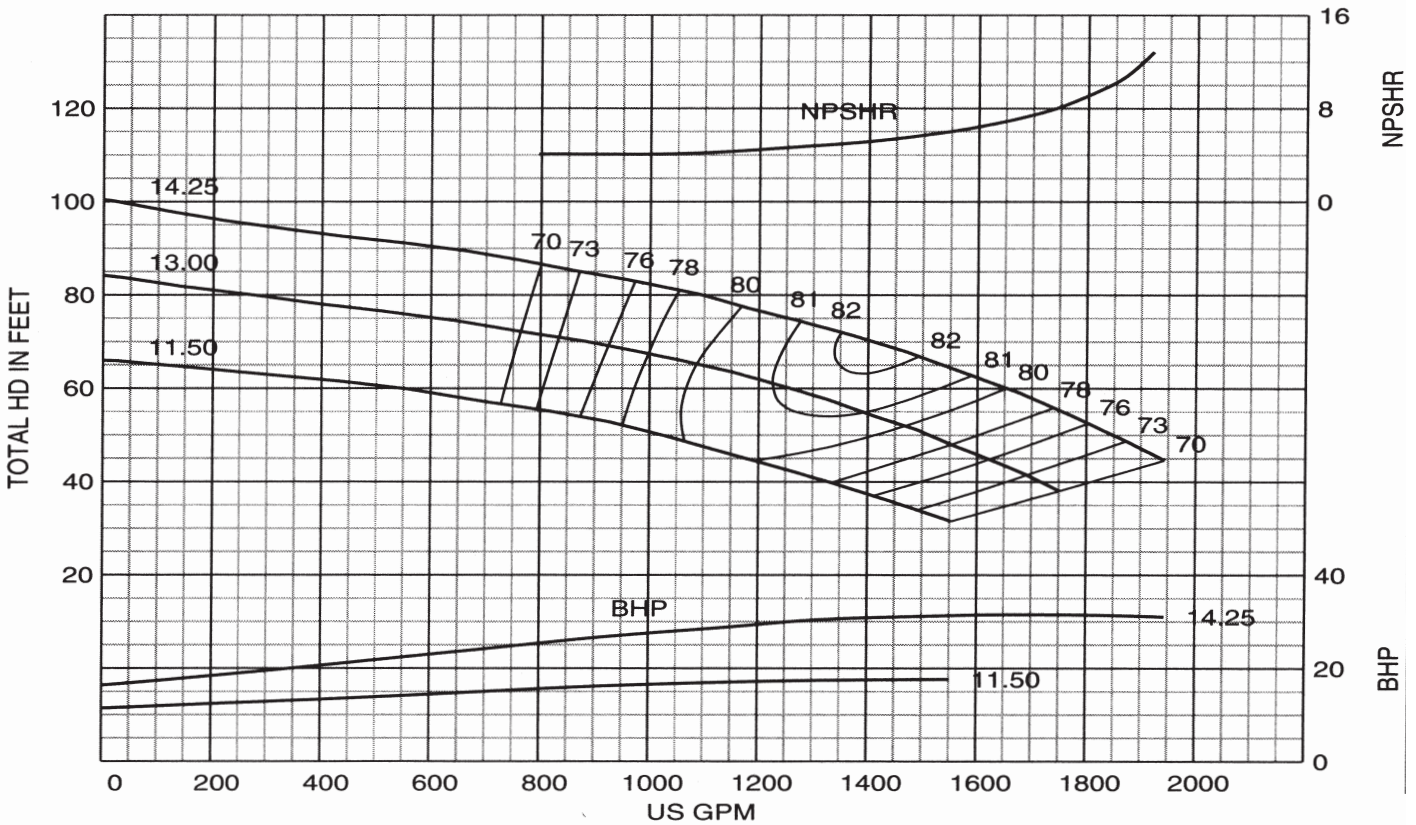

# Performance Curve – 8" 2823A

IMPELLER: J8H1A3 SUCTION: 12" INLET: 80.20 in<sup>2</sup>

RPM: 1185 SOLIDS: 1.12"

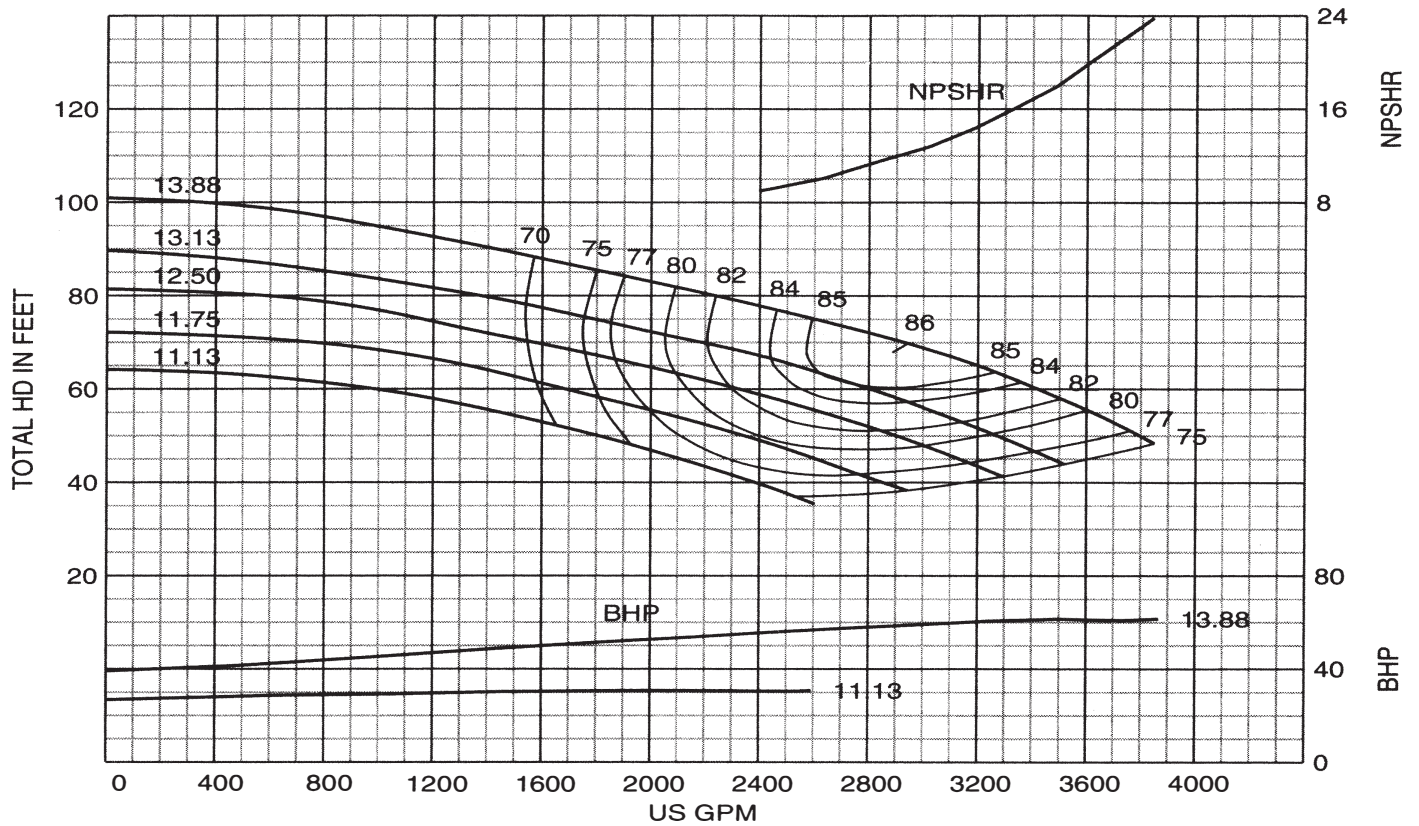

# Performance Curve – 10" 2823A

IMPELLER: J10H1A3 SUCTION: 14" INLET: 108.56 in<sup>2</sup>

RPM: 1185 SOLIDS: 1.22"

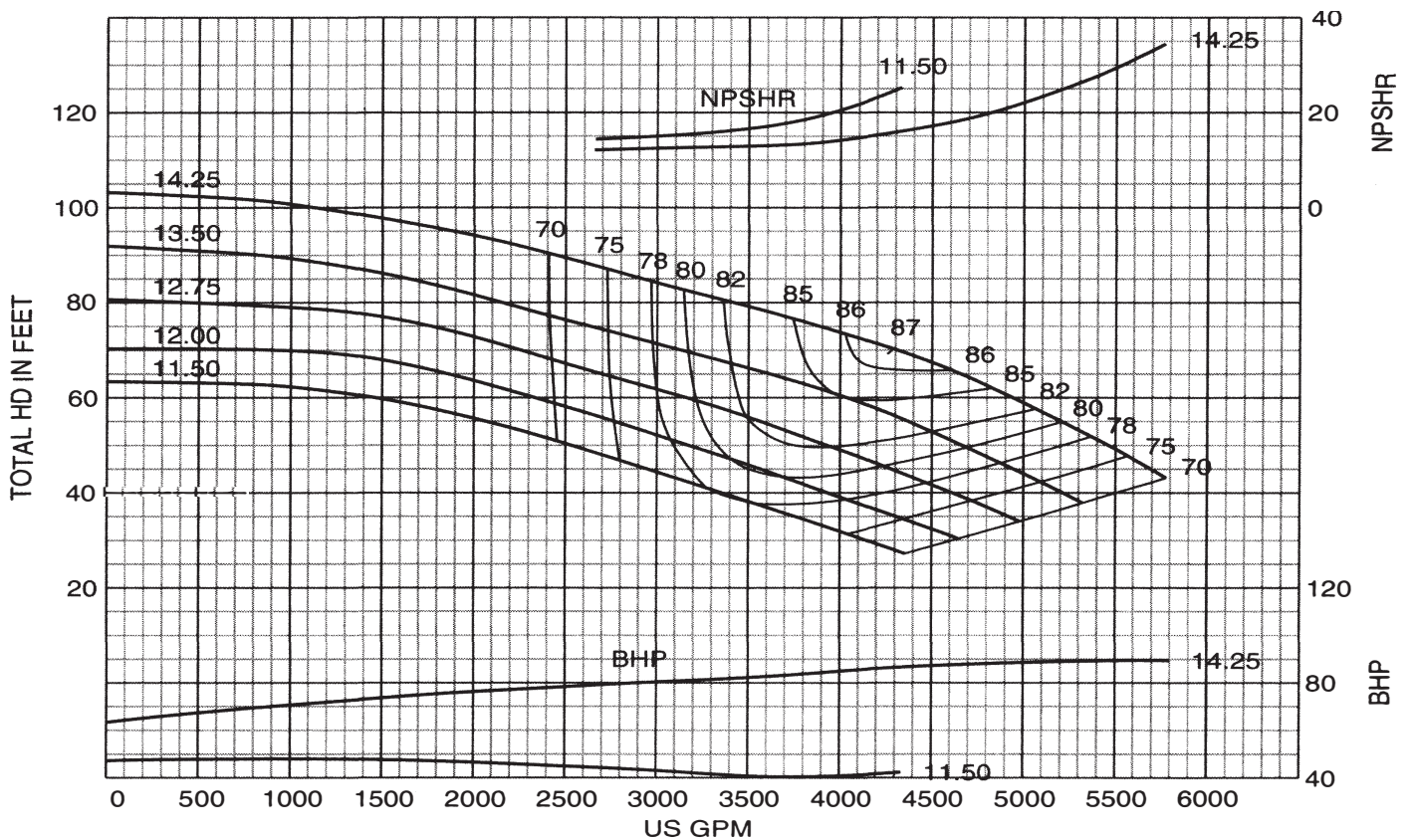

# Performance Curve - 5" 2824A

RPM: 1185 SOLIDS: .63"

IMPELLER: J5L1A1 SUCTION: 8" INLET: 33.38 in<sup>2</sup>

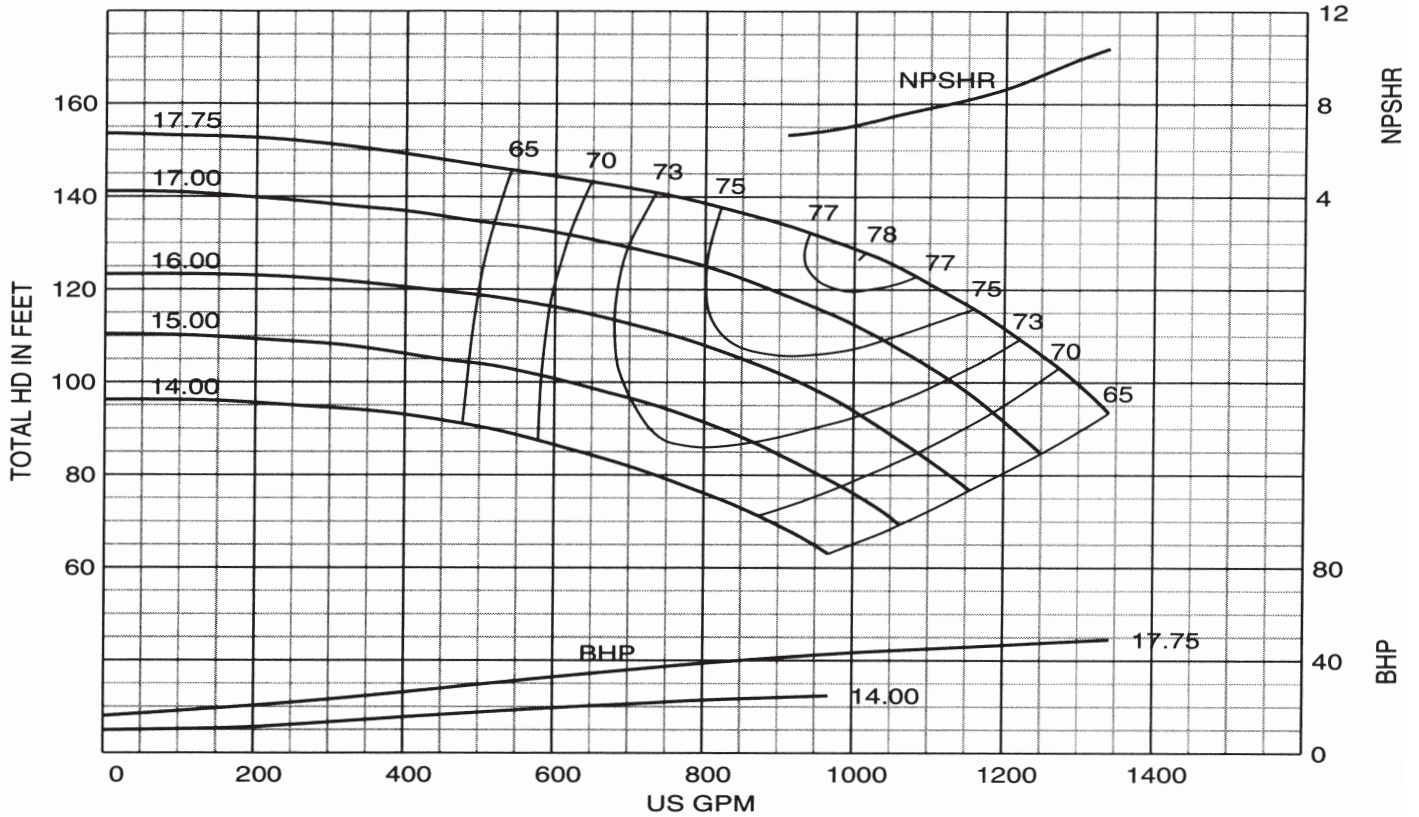

# Performance Curve - 6" 2824A

RPM: 1185 SOLIDS: 1.12"

IMPELLER: J6L1A1 SUCTION: 10" INLET: 60.30 in<sup>2</sup>

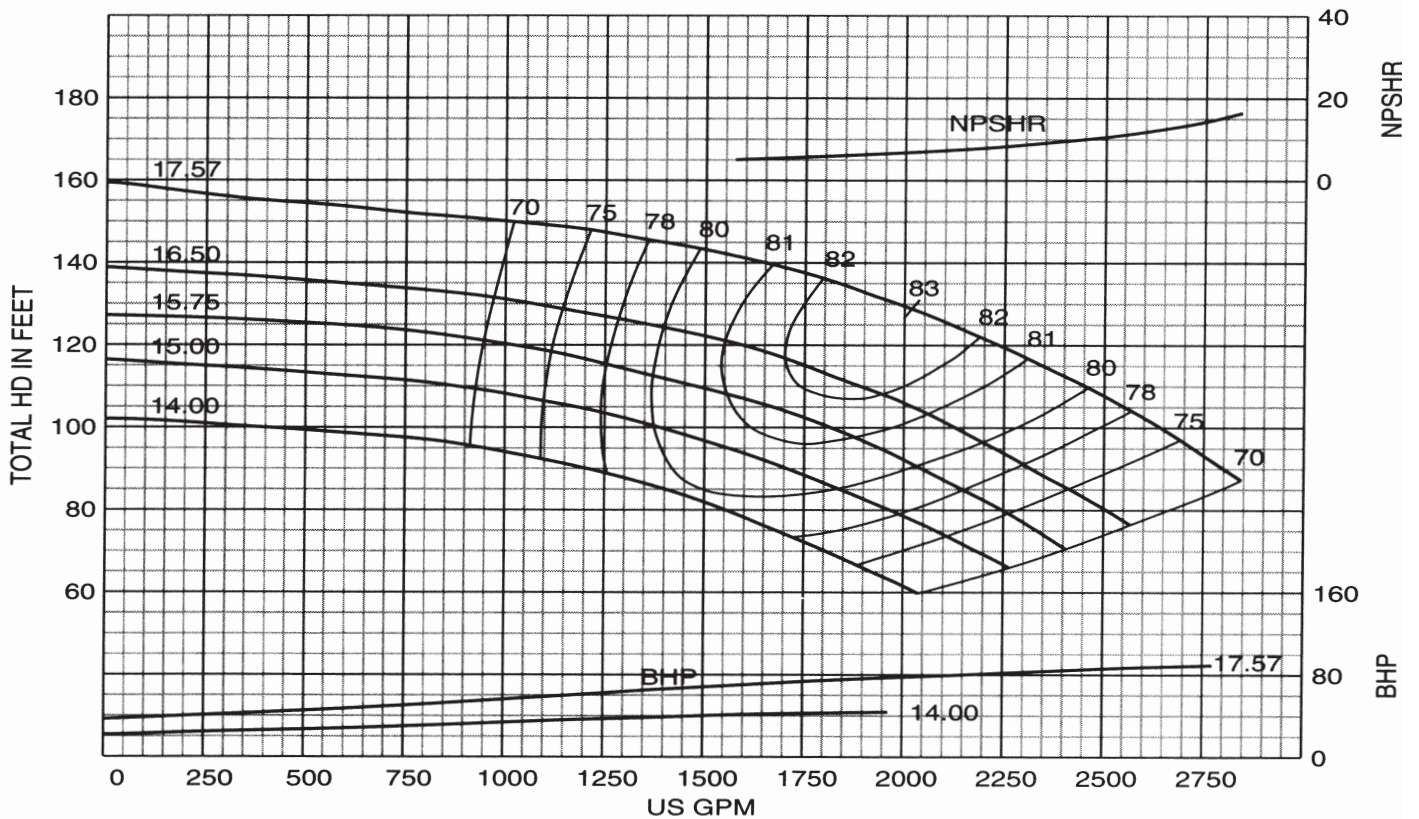

# Performance Curve – 6" 2824C

IMPELLER: J6L1C1 SUCTION: 10" INLET: 58.50 in<sup>2</sup>

RPM: 1185 SOLIDS: .87"

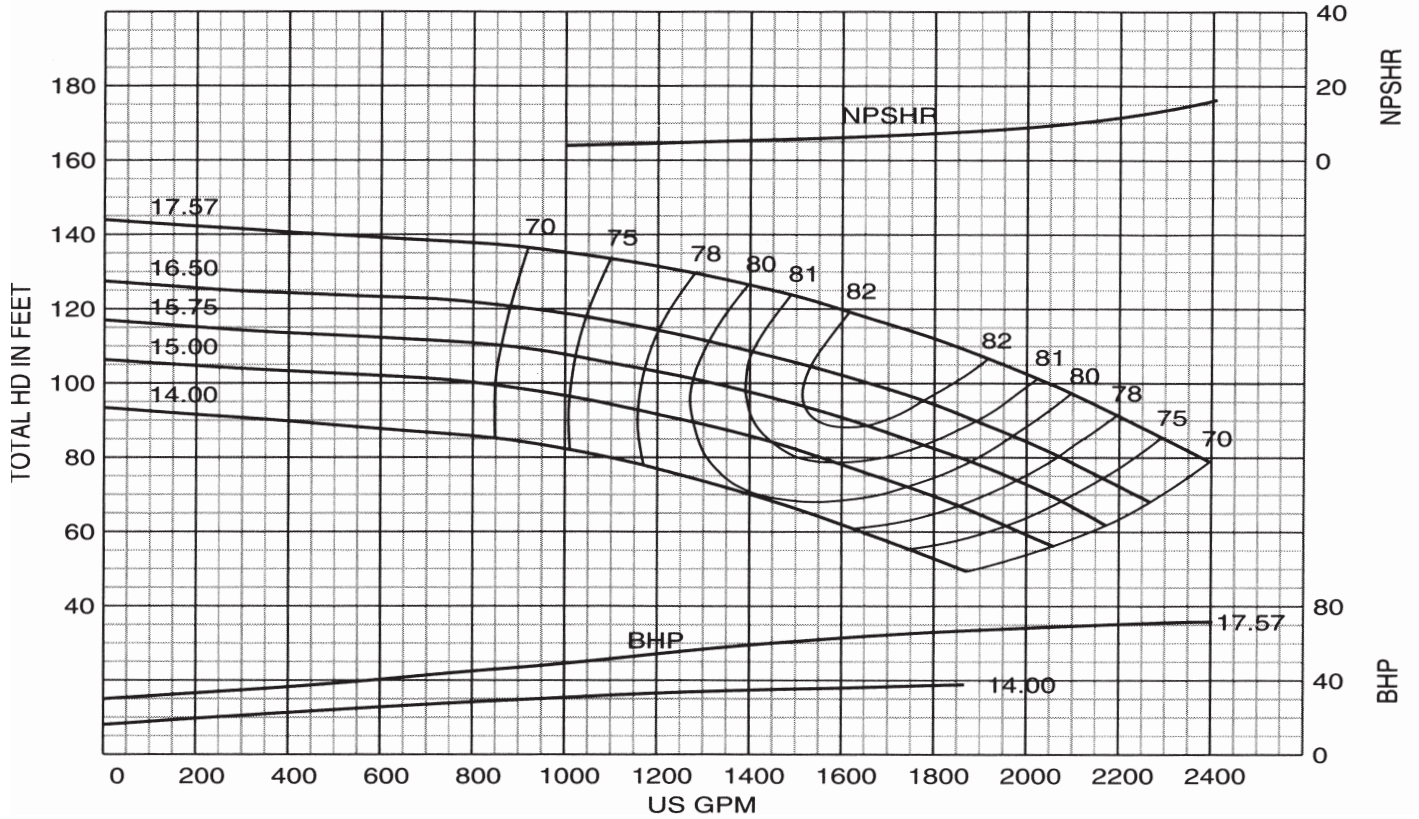

# Performance Curve – 8" 2824A

IMPELLER: J8L1A1 SUCTION: 12" INLET: 81.28 in<sup>2</sup>

RPM: 1185 SOLIDS: 1.12"

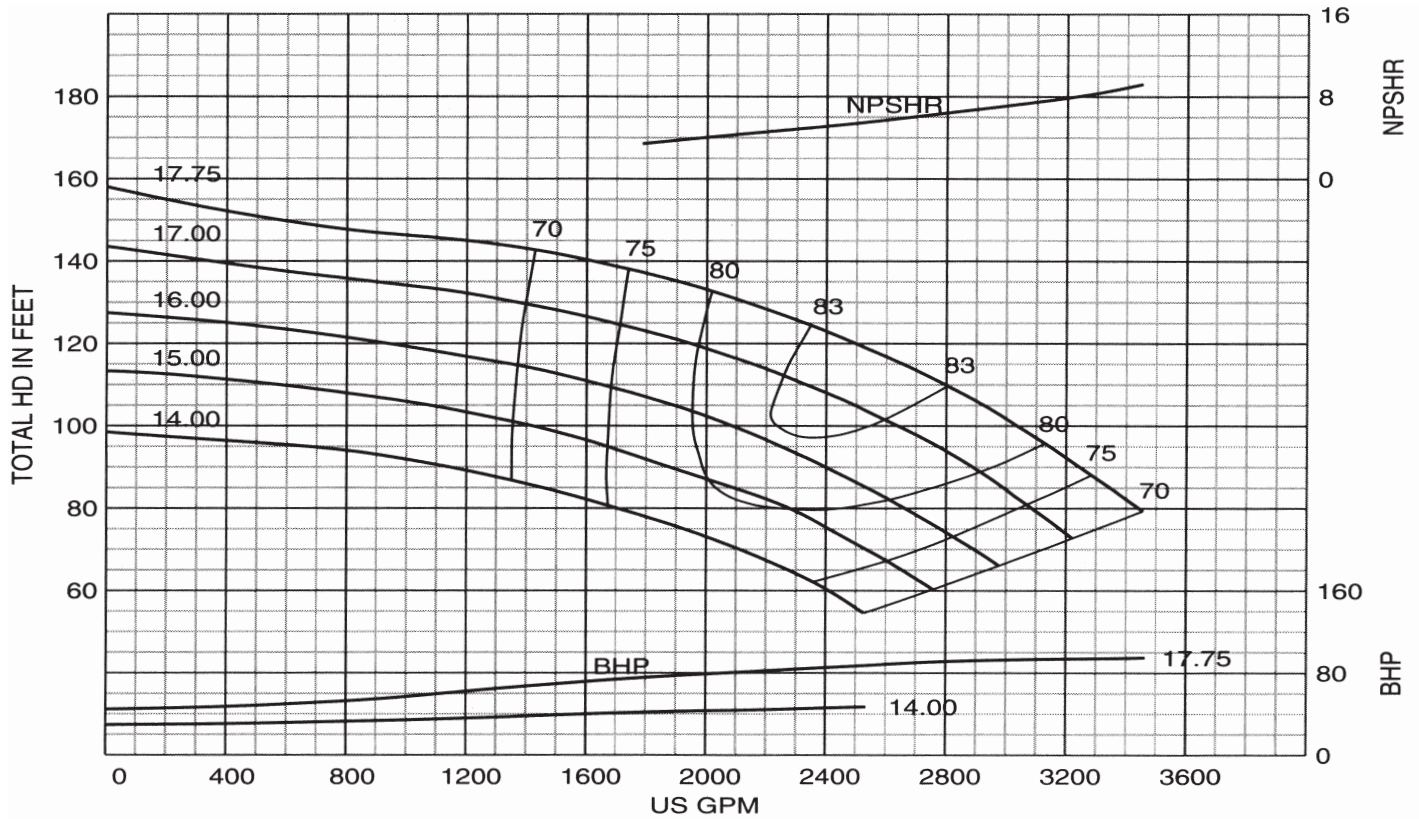

# Performance Curve - 10" 2824A

RPM: 1185 SOLIDS: 1.41"

IMPELLER: J10L1A1 SUCTION: 14" INLET: 128.4 in<sup>2</sup>

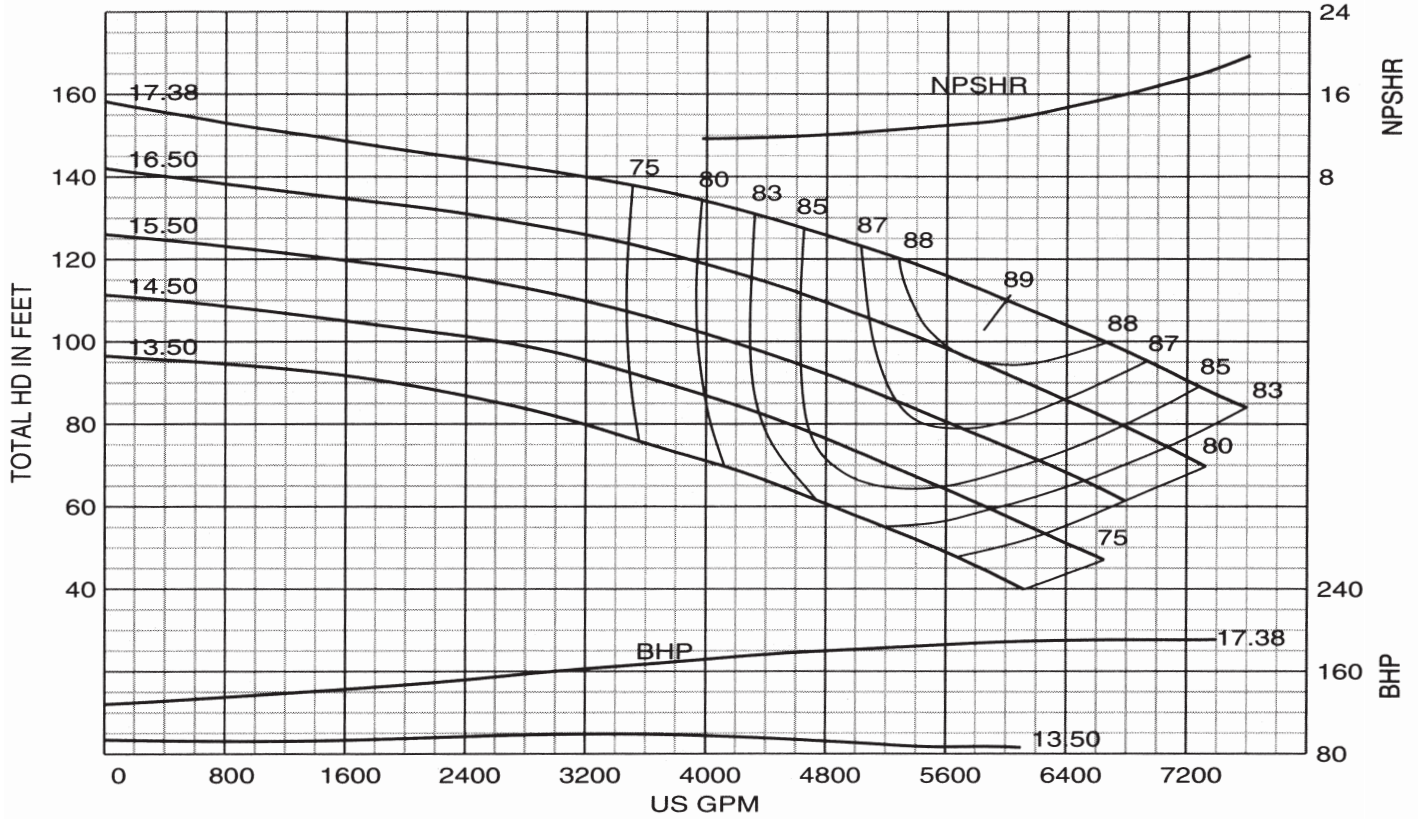

# Performance Curve - 6" 2825A

RPM: 1185 SOLIDS: .88"

IMPELLER: J6M1A1 SUCTION: 10" INLET: 62.64 in<sup>2</sup>

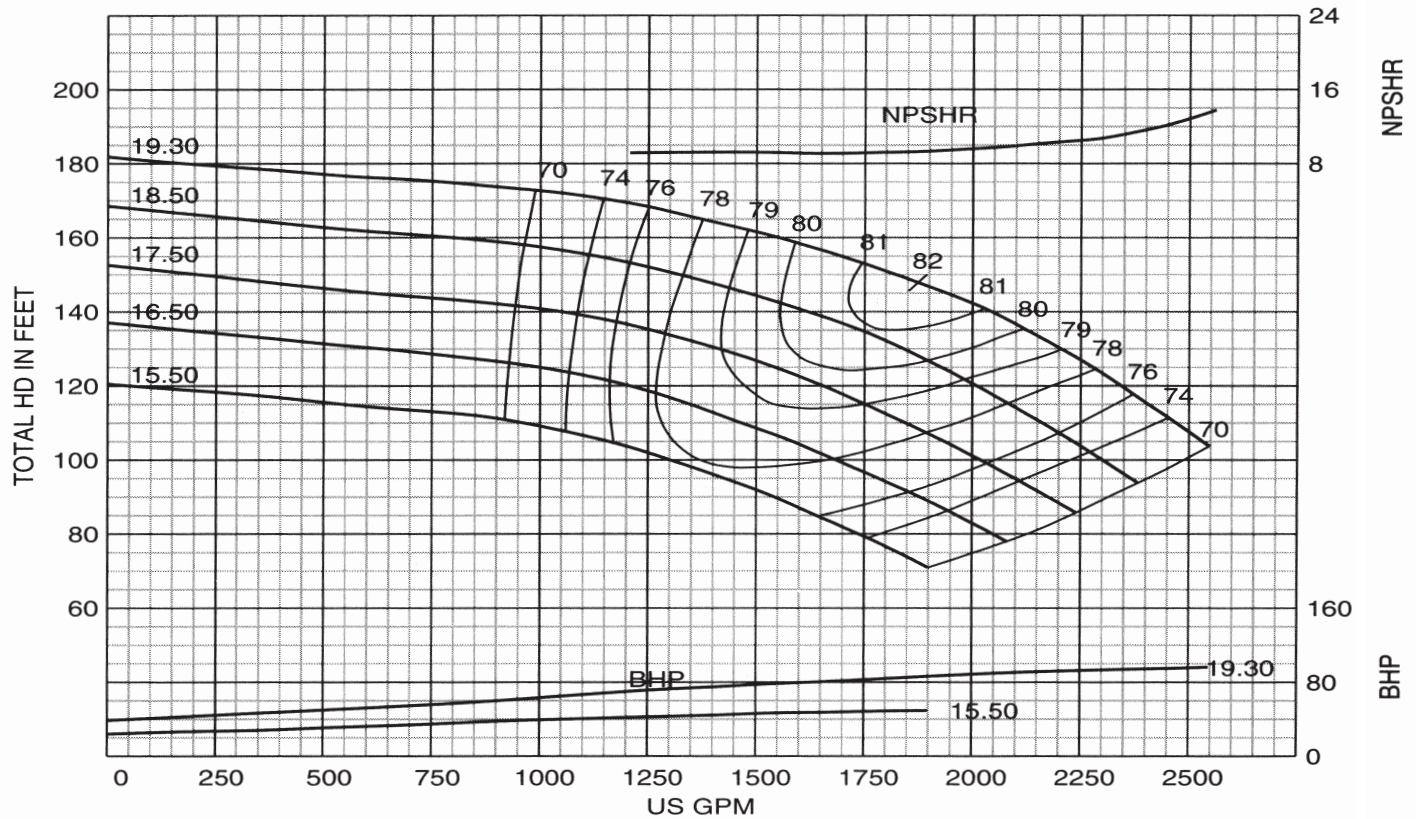

# Performance Curve – 10" 2825C

IMPELLER: J10M1A1 SUCTION: 12" INLET: 97.62 in<sup>2</sup>

RPM: 1185 SOLIDS: 1.12"

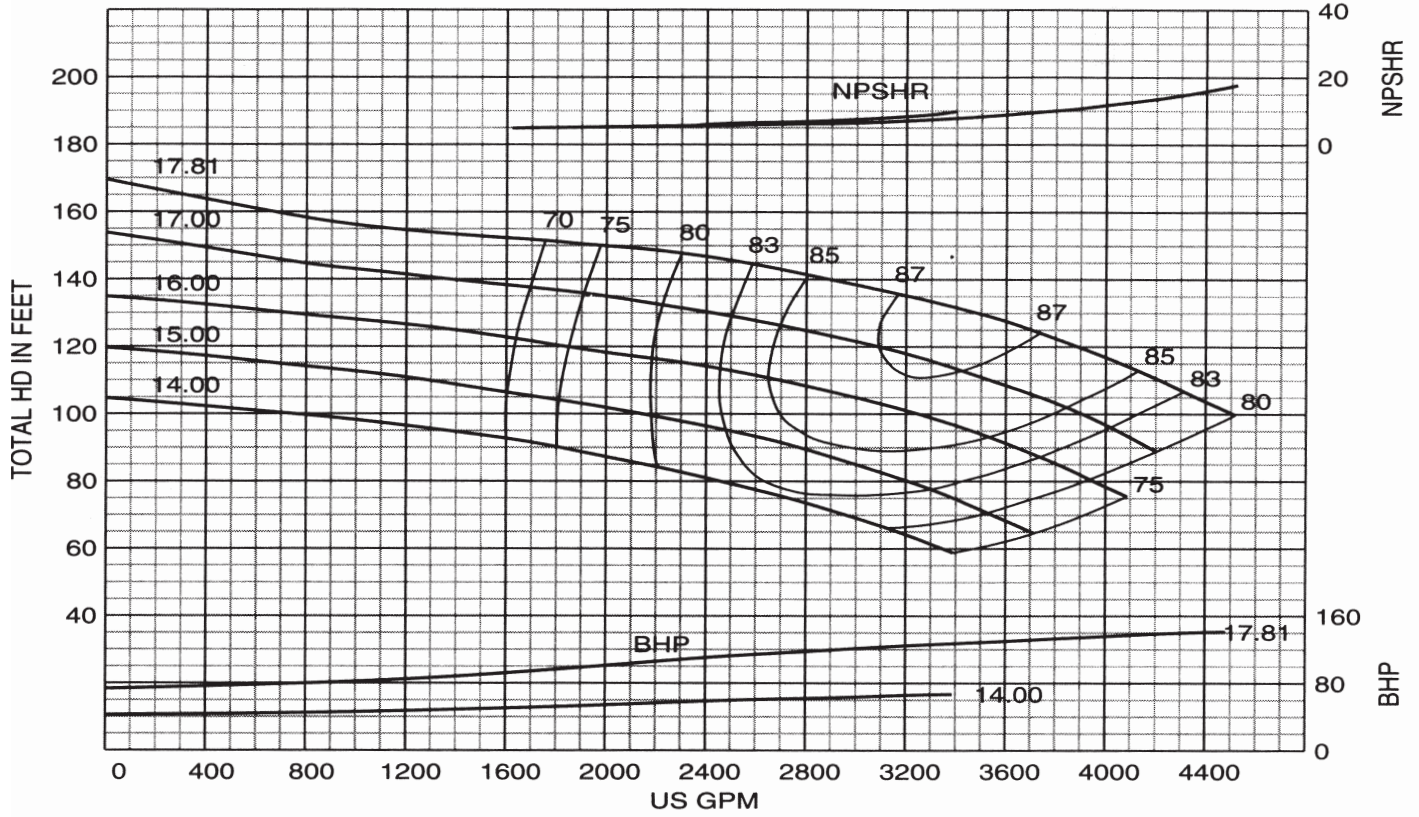

# Performance Curve – 10" 2825A

IMPELLER: J10M1C1 SUCTION: 16" INLET: 160 in<sup>2</sup>

RPM: 1175 SOLIDS: 2.0"

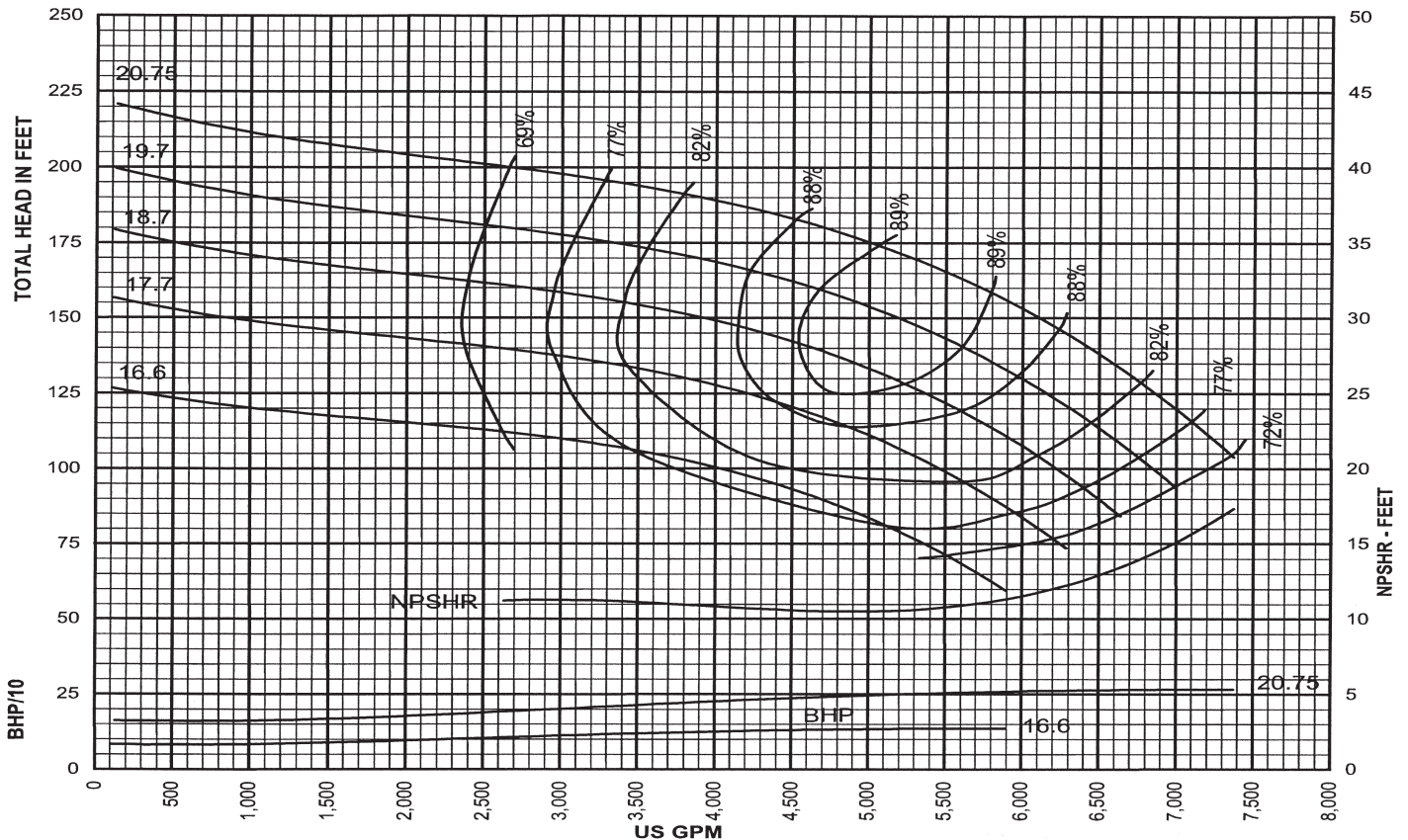

# Typical Specifications – BASIC PUMP DIMENSIONS 2821 & 2822

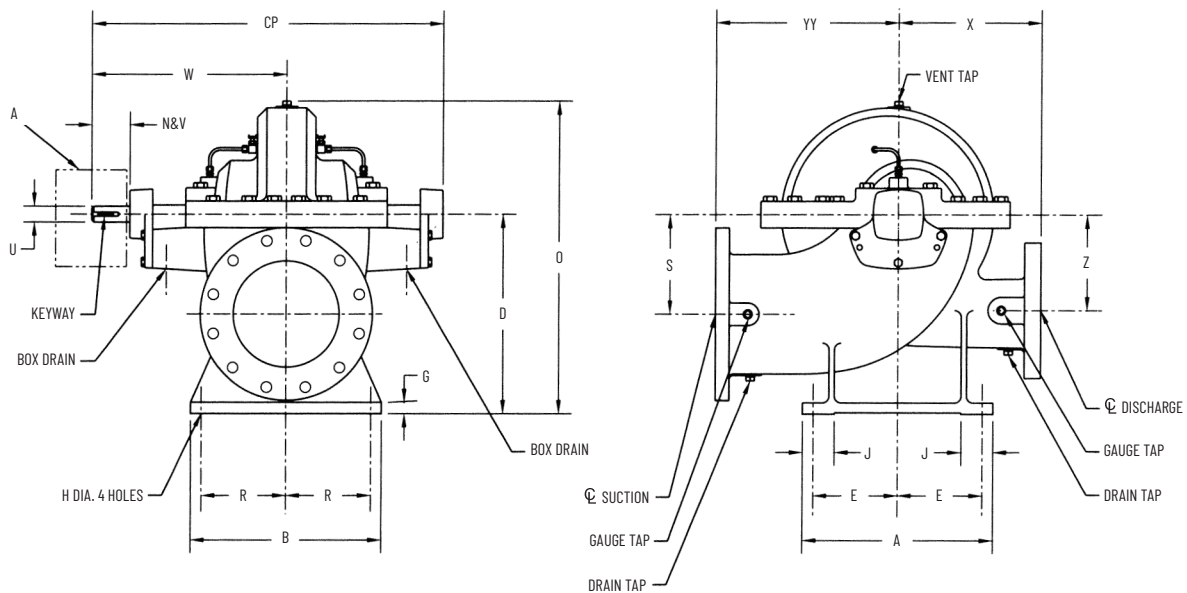

CLOCKWISE ROTATION SHOWN

PUMP	SUCT	DISCH	A	B	D	E	G	H	J	N&V	O
6" 2821	8	6	18	18	16-1/4	8	1-1/8	7/8	3	3-1/2	25-1/8
8" 2821	10	8	18	18	18-3/4	8	1-1/8	7/8	3	3-1/2	28-1/2
6" 2822	10	6	18	18	18-3/4	8	1-1/8	7/8	3	3-1/2	28-7/8
6" 2822X	6	6	14-1/2	14-1/2	10-1/2	6-1/4	3/4	7/8	2-7/8	3-1/2	18-1/8
8" 2822	10	8	18	18	18-3/4	8	1-1/8	7/8	3	4-3/8	29-1/2
10" 2822	14	10	22	22	24	10	1-1/8	7/8	3	4-3/8	35-7/8

PUMP	R	S	U	W	X	Z	CP	YY	KEYWAY
6" 2821	8	8-1/4	1-1/2	18-7/8	12-3/4	7-3/4	34-1/4	16	3/8 X 3/16 X 2-3/8
8" 2821	8	9-3/8	1-1/2	18-7/8	13-3/4	8-5/8	34-5/16	19	3/8 X 3/16 X 2-3/8
6" 2822	8	9-3/8	1-1/2	18-3/8	13-1/2	9	33-3/16	17-1/4	3/8 X 3/16 X 2-3/8
6" 2822X	6-1/4	7	1-1/2	15-3/4	15	7	28-1/4	12	1/4 X 1/8 X 2-1/2
8" 2822	8	9-3/8	2-1/8	20-1/8	14-3/8	9-3/8	35-7/8	19	1/2 X 1/4 X 3-1/2
10" 2822	10	12	2-1/8	21-3/8	17	10-3/8	39-3/8	22	1/2 X 1/4 X 3-1/2

## NOTES:

All flanges are standard 125# ANSI drilling. Optional 250# ANSI flanges are available.

All dimensions are in inches unless noted.

Rotation is always viewed from the driver end. For C.C.W. rotation, suction and discharge positions will be on opposite sides of that shown above and dimensions in the end view will be reversed.

Not for construction, installation, or application purposes unless certified. Dimensions shown may vary due to normal manufacturing tolerances.



# Typical Specifications – BASIC PUMP DIMENSIONS 2823

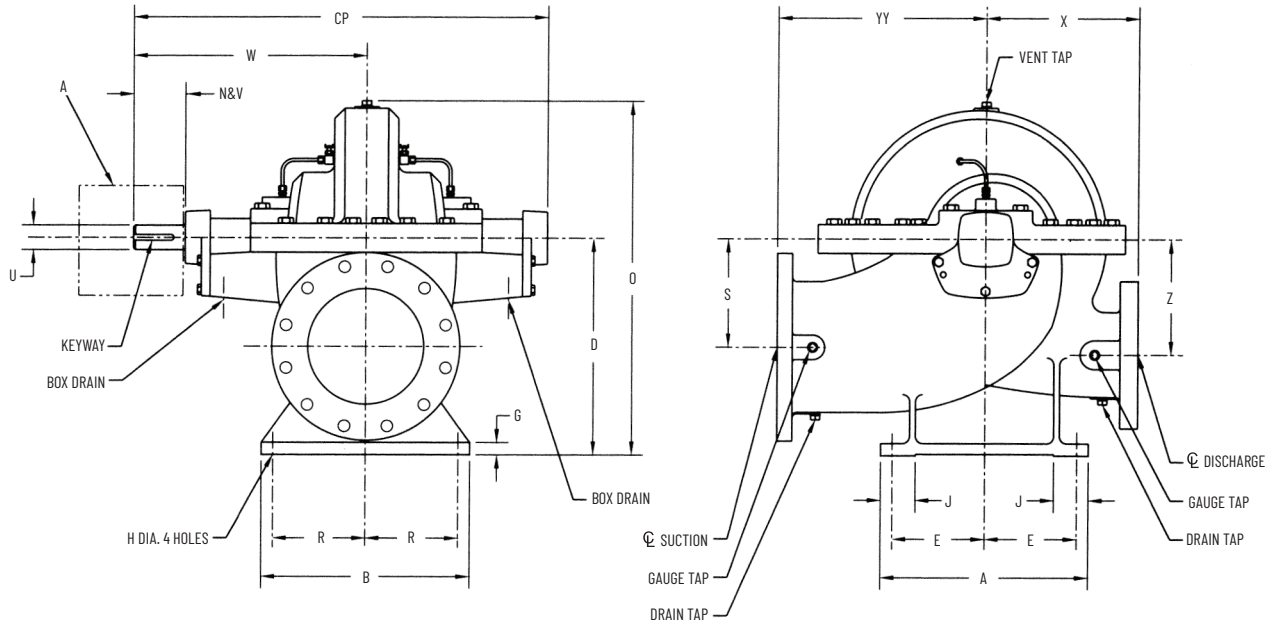

CLOCKWISE ROTATION SHOWN

PUMP	SUCT	DISCH	A	B	D	E	G	H	J	N&V	O
3" 2823	5	3	14-1/2	14-1/2	12	6-1/4	1	7/8	2-7/8	3-1/4	21-1/8
4" 2823	6	4	18	18	13-3/4	8	1-1/8	7/8	3	3-1/2	23-5/8
5" 2823	8	5	18	18	16-1/4	8	1-1/8	7/8	3	3-1/2	27-1/16
6" 2823	10	6	18	18	18-3/4	8	1-1/8	7/8	3	4-3/8	30-1/16
8" 2823	12	8	22	22	21-1/2	10	1-1/8	7/8	3	4-3/8	33-5/8
10" 2823	14	10	22	22	24	10	1-1/8	7/8	3	6	37-1/2

PUMP	R	S	U	W	X	Z	CP	YY	KEYWAY
3" 2823	6-1/4	6	1-1/8	16-1/4	12	7-3/4	29-5/16	14-5/8	1/4 X 1/8 X 2-1/2
4" 2823	8	6-7/8	1-1/2	17-5/8	13	8-3/8	31-11/16	15-1/4	3/8 X 3/16 X 2-3/8
5" 2823	8	8-1/4	1-1/2	17-5/8	13-1/2	9-3/4	31-11/16	17-1/4	3/8 X 3/16 X 2-3/8
6" 2823	8	9-3/8	2-1/8	20-1/8	13-1/4	10	35-7/8	18	1/2 X 1/4 X 3-1/2
8" 2823	10	10-3/4	2-1/8	20-1/2	16	10-3/4	36-5/8	22	1/2 X 1/4 X 3-1/2
10" 2823	10	12	2-1/2	23	16	11-7/8	40	25	5/8 X 5/16 X 4

## NOTES:

All flanges are standard 125# ANSI drilling. Optional 250# ANSI flanges are available.

All dimensions are in inches unless noted.

Rotation is always viewed from the driver end. For C.C.W. rotation, suction and discharge positions will be on opposite sides of that shown above and dimensions in the end view will be reversed.

Not for construction, installation, or application purposes unless certified. Dimensions shown may vary due to normal manufacturing tolerances.

# Typical Specifications – BASIC PUMP DIMENSIONS 2824 & 2825

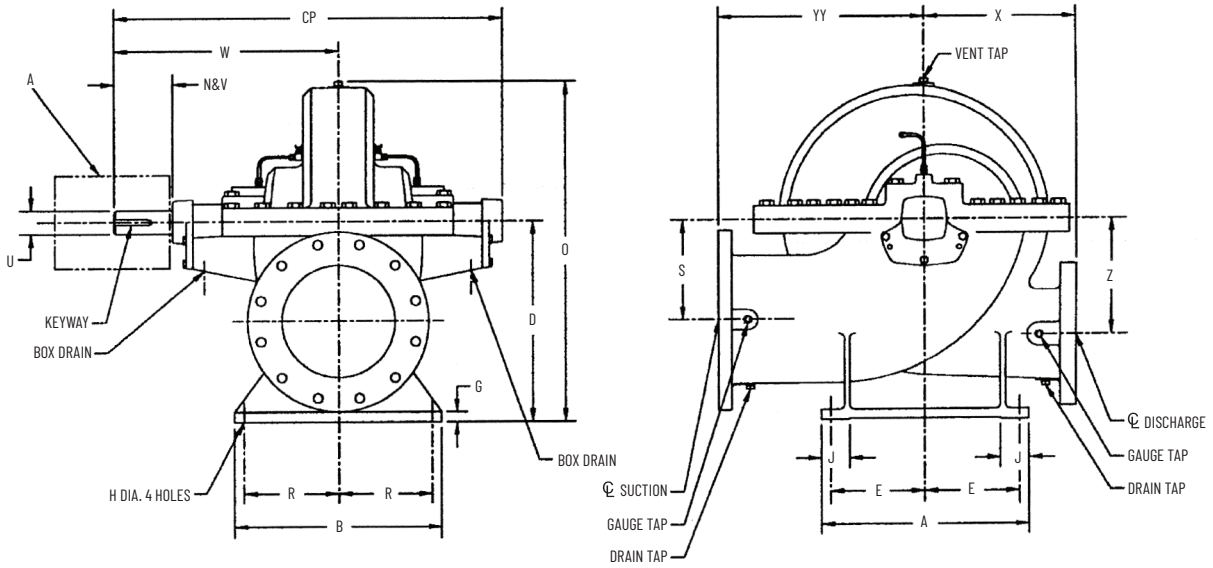

CLOCKWISE ROTATION SHOWN

PUMP	SUCT	DISCH	A	B	D	E	G	H	J	N&V	O
5" 2824	8	5	18	18	16-1/4	8	1-1/8	7/8	3	4-3/8	28-3/8
6" 2824	10	6	22	22	18-3/4	10	1-1/8	7/8	3	4-3/8	32
8" 2824	12	8	22	22	21-1/2	10	1-1/8	7/8	3	6	36
10" 2824	14	10	22	22	24	10	1-1/8	7/8	3	6	39-1/4
6" 2825	10	6	22	22	18-3/4	10	1-1/8	7/8	3	6	33-5/16
10" 2825A	16	10	22	22	24	10	1-1/4	7/8	3	6	39-3/4
10" 2825C	12	10	22	22	21-1/2	10	1-1/8	7/8	3	6	36

PUMP	R	S	U	W	X	Z	CP	YY	KEYWAY
5" 2824	8	8-1/8	2-1/8	18-7/8	15	10-5/8	33-3/8	18-3/4	1/2 X 1/4 X 3-1/2
6" 2824	10	9-3/8	2-1/8	20-1/8	16	11-3/4	35-7/8	20	1/2 X 1/4 X 3-1/2
8" 2824	10	10-3/4	2-1/2	23-3/4	16	12-1/2	41-1/2	22	5/8 X 5/16 X 4
10" 2824	10	12	2-1/2	26-1/4	18	14-7/8	46-1/2	28	5/8 X 5/16 X 4
6" 2825	10	9-3/8	2-1/2	22-5/8	18	12-1/8	39-1/4	22	5/8 X 5/16 X 4
10" 2825A	10	13	2-3/4	25-1/2	23	14-1/4	44-1/2	25	5/8 X 5/16 X 5
10" 2825C	10	10-3/4	2-1/2	23-3/4	18	12-1/2	41-1/2	22	5/8 X 5/16 X 4

## NOTES:

All flanges are standard 125# ANSI drilling. Optional 250# ANSI flanges are available.

All dimensions are in inches unless noted.

Rotation is always viewed from the driver end. For C.C.W. rotation, suction and discharge positions will be on opposite sides of that shown and dimensions in the end view will be reversed.

Not for construction, installation, or application purposes unless certified. Dimensions shown may vary due to normal manufacturing tolerances.

# Typical Specifications – BASIC PUMP DIMENSIONS 2873

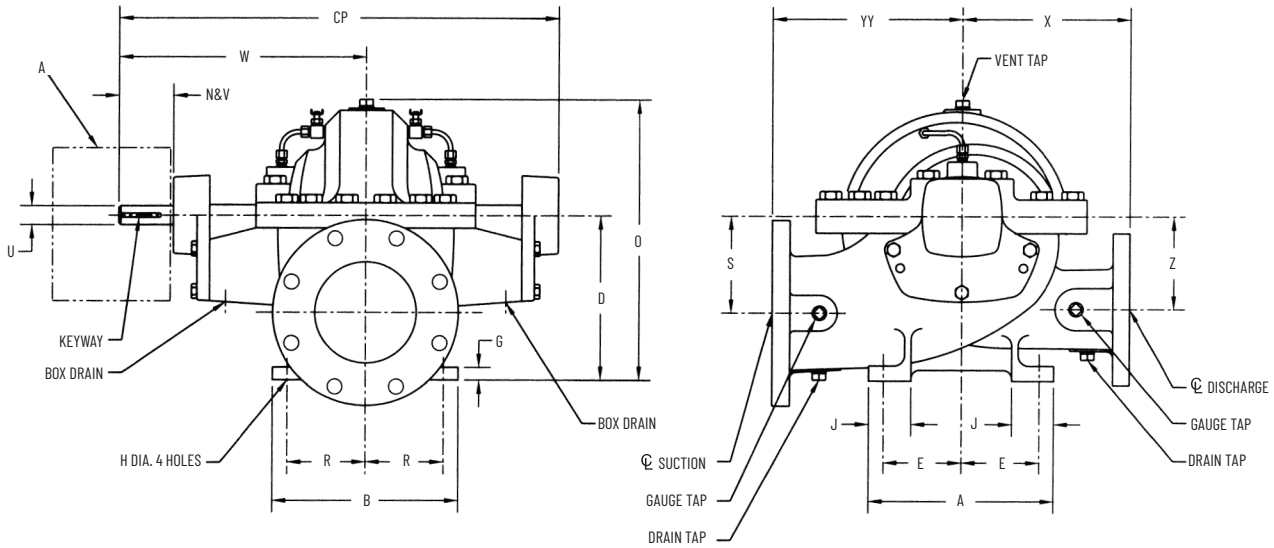

CLOCKWISE ROTATION SHOWN

PUMP	SUCT	DISCH	A	B	D	E	G	H	J	N&V	O
2" 2873	4	2	11	11	9-3/4	4-5/8	7/8	5/8	2-1/2	3-1/4	15-1/2
4" 2873	6	4	11	11	9-3/4	4-5/8	3/4	5/8	2-1/2	3-1/4	16-1/8

PUMP	R	S	U	W	X	Z	CP	YY	KEYWAY
2" 2873	4-5/8	4-7/8	15/16	14	9	5-1/8	24-13/16	10	1/4 X 1/8 X 1-1/2
4" 2873	4-5/8	5-3/4	1-1/8	14-5/8	10	5-1/2	25-15/16	11-1/4	1/4 X 1/8 X 2-1/2

## NOTES:

All flanges are standard 125# ANSI drilling. Optional 250# ANSI flanges are available.

All dimensions are in inches unless noted.

Rotation is always viewed from the driver end. For C.C.W. rotation, suction and discharge positions will be on opposite sides of that shown above and dimensions in the end view will be reversed.

Not for construction, installation, or application purposes unless certified. Dimensions shown may vary due to normal manufacturing tolerances.

# Typical Specifications – BASIC PUMP DIMENSIONS 2874 & 2876

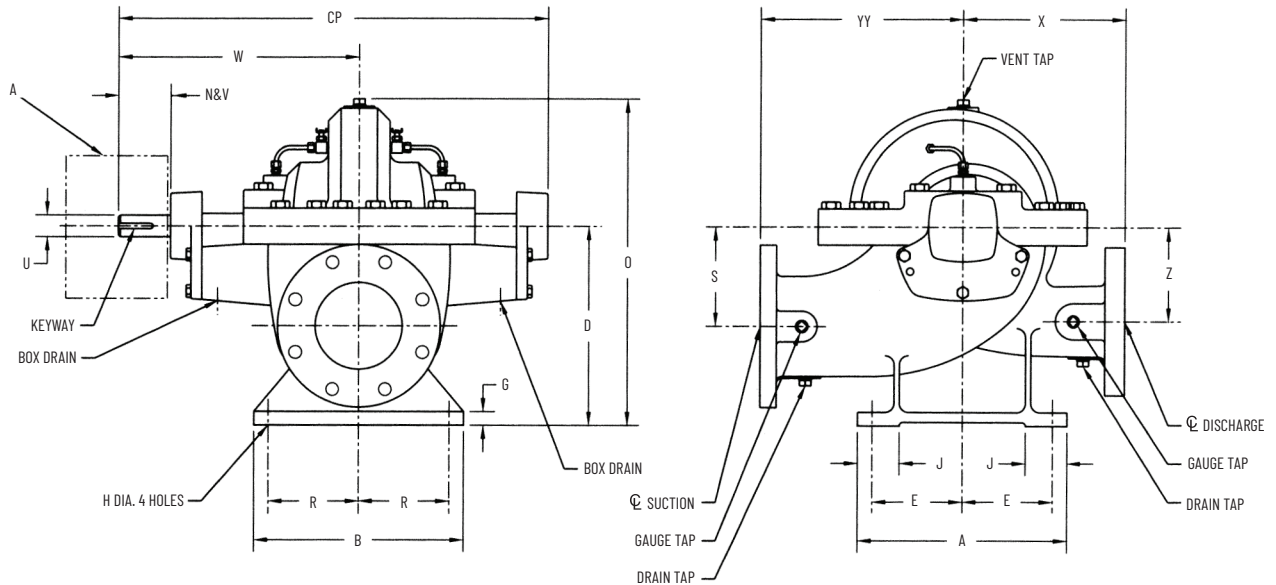

CLOCKWISE ROTATION SHOWN

PUMP	SUCT	DISCH	A	B	D	E	G	H	J	N&V	O
3" 2874	5	3	14-1/2	14-1/2	12	6-1/4	1	7/8	2-7/8	3-5/16	18-7/8
4" 2874	6	4	14-1/2	14-1/2	13-3/4	6-1/4	1	7/8	2-7/8	3-1/2	21-1/8
5" 2874	8	5	14-1/2	14-1/2	16-1/4	6-1/4	1	7/8	2-7/8	4-3/8	24-1/4
4" 2876	6	4	14-1/2	14-1/2	13-3/4	6-1/4	1	7/8	2-7/8	3-1/2	22
5" 2876	8	5	14-1/2	14-1/2	16-1/4	6-1/4	1	7/8	2-7/8	6	25-1/2

PUMP	R	S	U	W	X	Z	CP	YY	KEYWAY
3" 2874	6-1/4	6-1/8	1-1/8	14-5/8	11	6-1/8	25-15/16	12	1/4 X 1/8 X 2-1/2
4" 2874	6-1/4	6-7/8	1-1/2	16-5/8	11-1/2	6-1/2	29-11/16	13-3/8	3/8 X 3/16 X 2-3/8
5" 2874	6-1/4	8-1/4	2-1/8	18-3/4	11-3/4	7	33-1/8	14-1/2	1/2 X 1/4 X 3-1/2
4" 2876	6-1/4	6-7/8	1-1/2	16-5/8	11-1/4	7-1/8	29-11/16	14	3/8 X 3/16 X 2-3/8
5" 2876	6-1/4	8-1/4	2-1/2	21-1/2	12	8-1/4	37	16-1/2	5/8 X 5/16 X 4

## NOTES:

All flanges are standard 125# ANSI drilling. Optional 250# ANSI flanges are available.

All dimensions are in inches unless noted.

Rotation is always viewed from the driver end. For C.C.W. rotation, suction and discharge positions will be on opposite sides of that shown above and dimensions in the end view will be reversed.

Not for construction, installation, or application purposes unless certified. Dimensions shown may vary due to normal manufacturing tolerances.

# Typical Specifications – SETTING PLAN 6" 2821A BENT FORM BASE

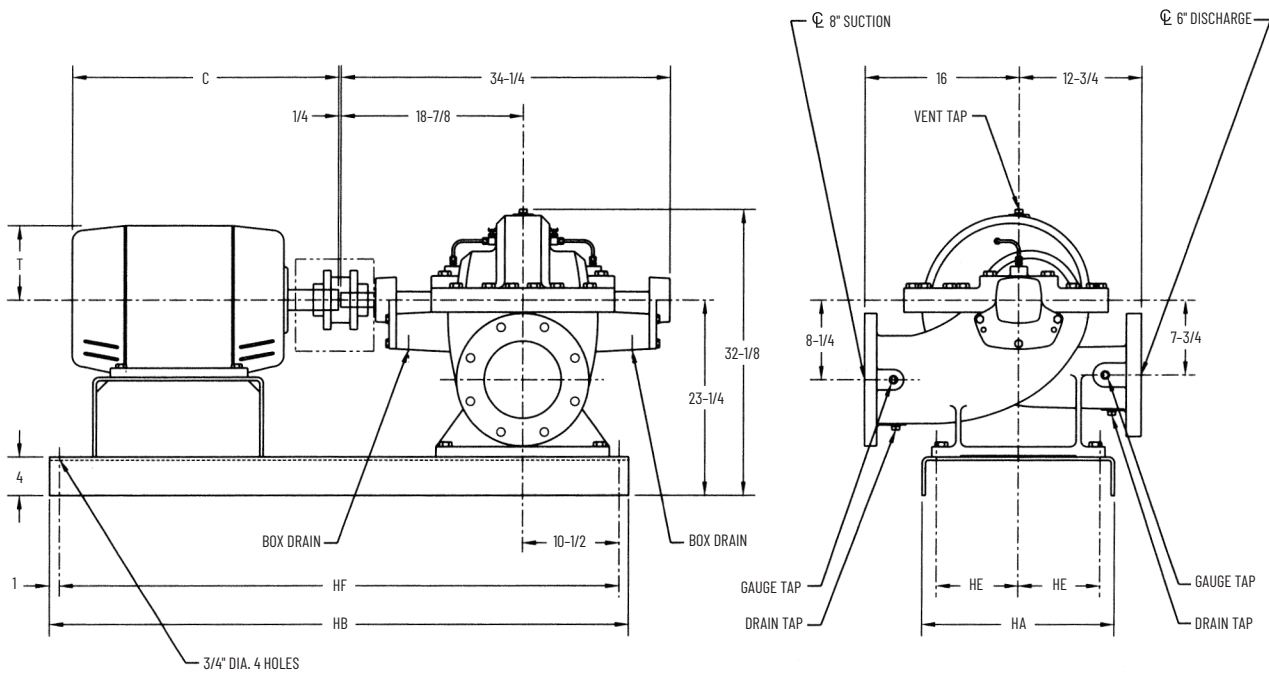

CLOCKWISE ROTATION SHOWN

MOTOR FRAME SIZE	UNIT DIMENSIONS				MOTOR	
	HA	HB	HE	HF	C	T
213T	20	54	8-1/2	52	16	5-1/8
215T	20	54	8-1/2	52	17-1/2	5-1/8
254T	20	54	8-1/2	52	20-5/8	6-3/8
256T	20	54	8-1/2	52	22-3/8	6-3/8
284TS	20	60	8-1/2	58	22-1/8	7
284T	20	60	8-1/2	58	23-1/2	7

MOTOR FRAME SIZE	UNIT DIMENSIONS				MOTOR	
	HA	HB	HE	HF	C	T
286TS	20	60	8-1/2	58	23-5/8	7
286T	20	60	8-1/2	58	25	7
324TS	20	60	8-1/2	58	24-5/8	8
324T	20	60	8-1/2	58	26-1/8	8
326TS	20	60	8-1/2	58	26-1/8	8
326T	20	60	8-1/2	58	27-5/8	8

**NOTES:**

All flanges are standard 125# ANSI drilling. Optional 250# ANSI flanges are available.

All dimensions are in inches unless noted.

Rotation is always viewed from the driver end. For C.C.W. rotation, suction and discharge positions will be on opposite sides of that shown above and dimensions in the end view will be reversed.

Bases are designed to be completely filled with grout.

Not for construction, installation, or application purposes unless certified. Dimensions shown may vary due to normal manufacturing tolerances.

# Typical Specifications – SETTING PLAN 6" 2821A OPTIONAL STRUCTURAL BASE

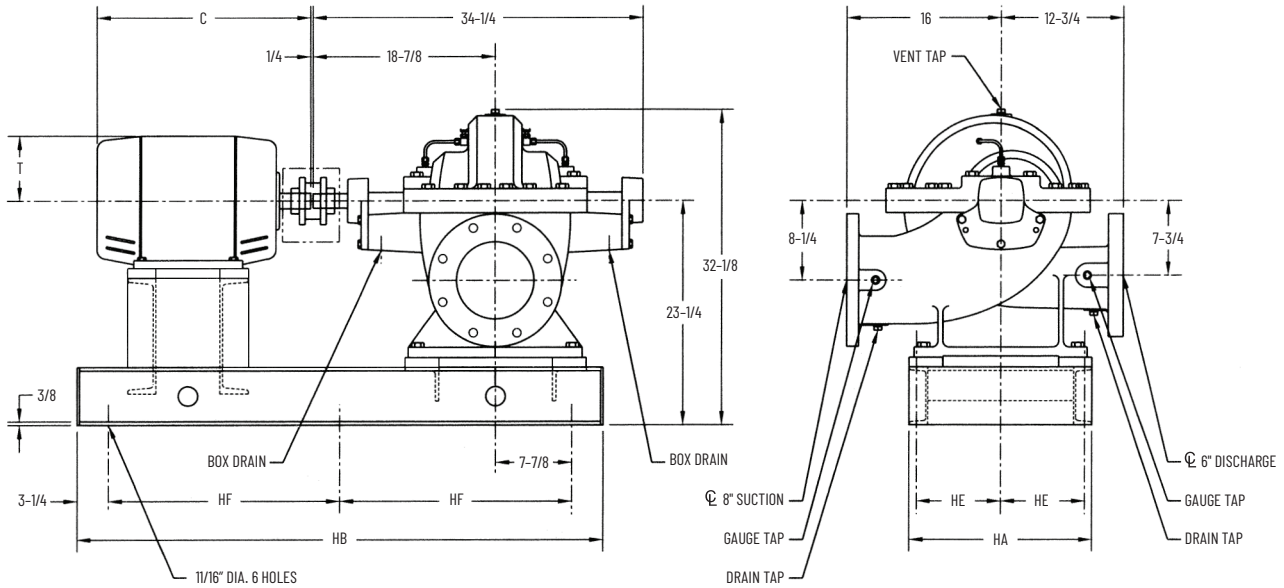

CLOCKWISE ROTATION SHOWN

MOTOR FRAME SIZE	UNIT DIMENSIONS					
	BASE				MOTOR	
	HA	HB	HE	HF	C	T
213T	19	48-1/2	8-3/4	21	16	5-1/8
215T	19	48-1/2	8-3/4	21	17-1/2	5-1/8
254T	19	54-1/2	8-3/4	24	20-5/8	6-3/8
256T	19	54-1/2	8-3/4	24	22-3/8	6-3/8
284TS	19	54-1/2	8-3/4	24	22-1/8	7
284T	19	54-1/2	8-3/4	24	23-1/2	7

MOTOR FRAME SIZE	UNIT DIMENSIONS					
	BASE				MOTOR	
	HA	HB	HE	HF	C	T
286TS	19	54-1/2	8-3/4	24	23-5/8	7
286T	19	54-1/2	8-3/4	24	25	7
324TS	19	54-1/2	8-3/4	24	24-5/8	8
324T	19	54-1/2	8-3/4	24	26-1/8	8
326TS	19	54-1/2	8-3/4	24	26-1/8	8
326T	19	60-1/2	8-3/4	24	27-5/8	8

## NOTES:

All flanges are standard 125# ANSI drilling. Optional 250# ANSI flanges are available.

All dimensions are in inches unless noted.

Rotation is always viewed from the driver end. For C.C.W. rotation, suction and discharge positions will be on opposite sides of that shown above and dimensions in the end view will be reversed.

Bases are designed to be completely filled with grout.

Not for construction, installation, or application purposes unless certified. Dimensions shown may vary due to normal manufacturing tolerances.

# Typical Specifications – SETTING PLAN 8" 2821A BENT FORM BASE

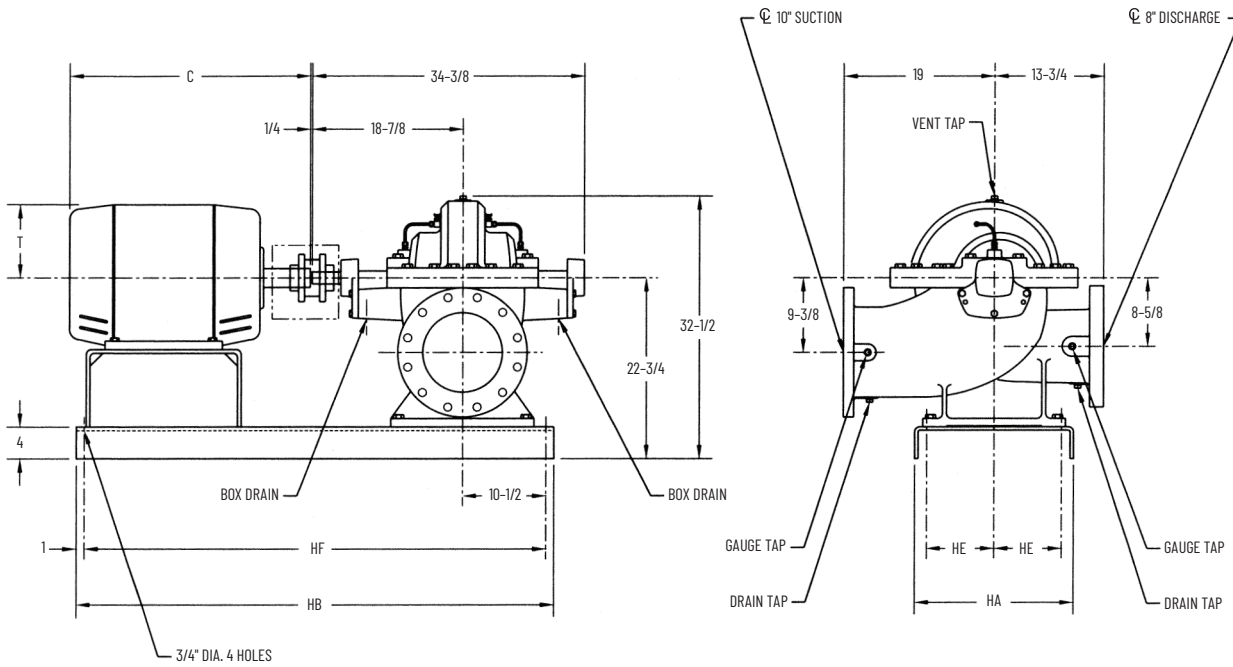

CLOCKWISE ROTATION SHOWN

MOTOR FRAME SIZE	UNIT DIMENSIONS				MOTOR	
	HA	HB	HE	HF	C	T
215T	20	54	8-1/2	52	17-1/2	5-1/8
254T	20	54	8-1/2	52	20-5/8	6-3/8
256T	20	54	8-1/2	52	22-3/8	6-3/8
284TS	20	60	8-1/2	58	22-1/8	7
284T	20	60	8-1/2	58	23-1/2	7
286TS	20	60	8-1/2	58	23-5/8	7
286T	20	60	8-1/2	58	25	7
324TS	20	60	8-1/2	58	24-5/8	8

MOTOR FRAME SIZE	UNIT DIMENSIONS				MOTOR	
	HA	HB	HE	HF	C	T
324T	20	60	8-1/2	58	26-1/8	8
326TS	20	60	8-1/2	58	26-1/8	8
326T	20	60	8-1/2	58	27-5/8	8
364TS	20	60	8-1/2	58	26-5/8	9-1/4
364T	20	60	8-1/2	58	28-3/4	9-1/4
365TS	20	60	8-1/2	58	27-5/8	9-1/4
365T	20	60	8-1/2	58	29-3/4	9-1/4

**NOTES:**

All flanges are standard 125# ANSI drilling. Optional 250# ANSI flanges are available.

All dimensions are in inches unless noted.

Rotation is always viewed from the driver end. For C.C.W. rotation, suction and discharge positions will be on opposite sides of that shown above and dimensions in the end view will be reversed.

Bases are designed to be completely filled with grout.

Not for construction, installation, or application purposes unless certified. Dimensions shown may vary due to normal manufacturing tolerances.