



SHURFLO BILGE PUMP - 1000 GALLONS PER HOUR

MARINE BILGE PUMP – PRODUCT TECHNICAL DATA SHEET

OEM: 355-100-00
AFTERMARKET: 355-100-10



APPLICATION:

12V DC Marine Bilge water evacuation

QUALITY BILGE PUMPS YOU CAN TRUST. SHURFLO BILGE PUMPS ARE BUILT FOR THE HARSH MARINE ENVIRONMENT TO WITHSTAND THE TOUGHEST CONDITIONS. STANDARD WITH 3' TINNED WIRE ASSEMBLY FOR ABOVE WATERLINE INSTALLATIONS AND WATER COOLED MOTORS FOR EXTENDED LIFE.

PUMP DESIGN:

Type: Centrifugal
Port: 1-1/8" Barb
Liquid: 130°F [54°C] Max
Dry-Prime: No (flooded Inlet)
Inlet PSI: 0 PSI [0 Bar]
Run Dry: No

ELECTRICAL:

Motor: 12V DC Permanent Magnet, Continuous Duty
Protection: Need External Fuse (Not Supplied)
Leads: 3 Ft. [0.9M] Tinned 16 AWG
Fuse: 6 Amp Recommended
Control: No Control

No Repair Kits Available

MATERIALS OF CONSTRUCTION:

Housing: ABS
Impeller: High Strength Nylon
Hardware: Stainless Steel

AGENCY APPROVALS:

Ignition Protection 8846, CE, IMCI Certified

SHIPPING INFORMATION:

Approx. Net Weight: 0.8 Pounds [0.36 Kg] ea.
Carton Qty.: 24
Approx. Carton Weight: 30 Lbs. [13.6 Kg]
Approx. Carton Size: 24"L X 18"W X 6"H [61cm x 46cm x 15cm]

RELATED DOCUMENTS:

Catalog: MS-030-140
 Application Spec Guide: MS-020-005
 Installation Manual: 911-758
 Aftermarket Warranty: 911-104

TYPICAL PERFORMANCE AT 13.6V

PRESSURE		FLOW		CURRENT
METERS	FEET	GPH	LPH	AMPS
0.00	0	1000	3785	1.95
1.67	5.5	720	2725	3.94
2.56	8.4	240	908	3.59
2.74	9.0	0	0	3.35

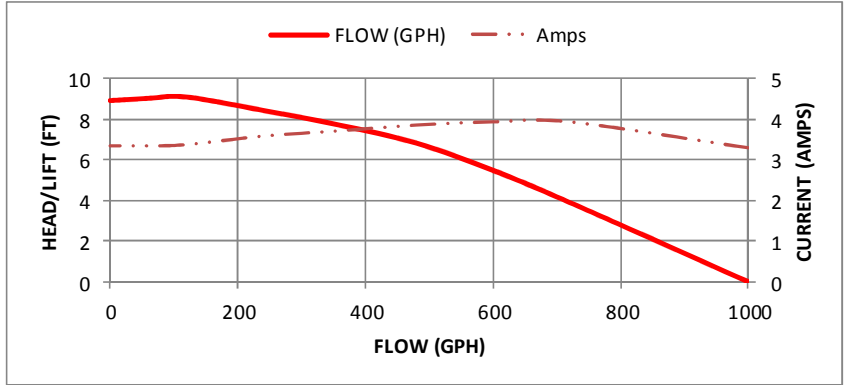

DIMENSIONS

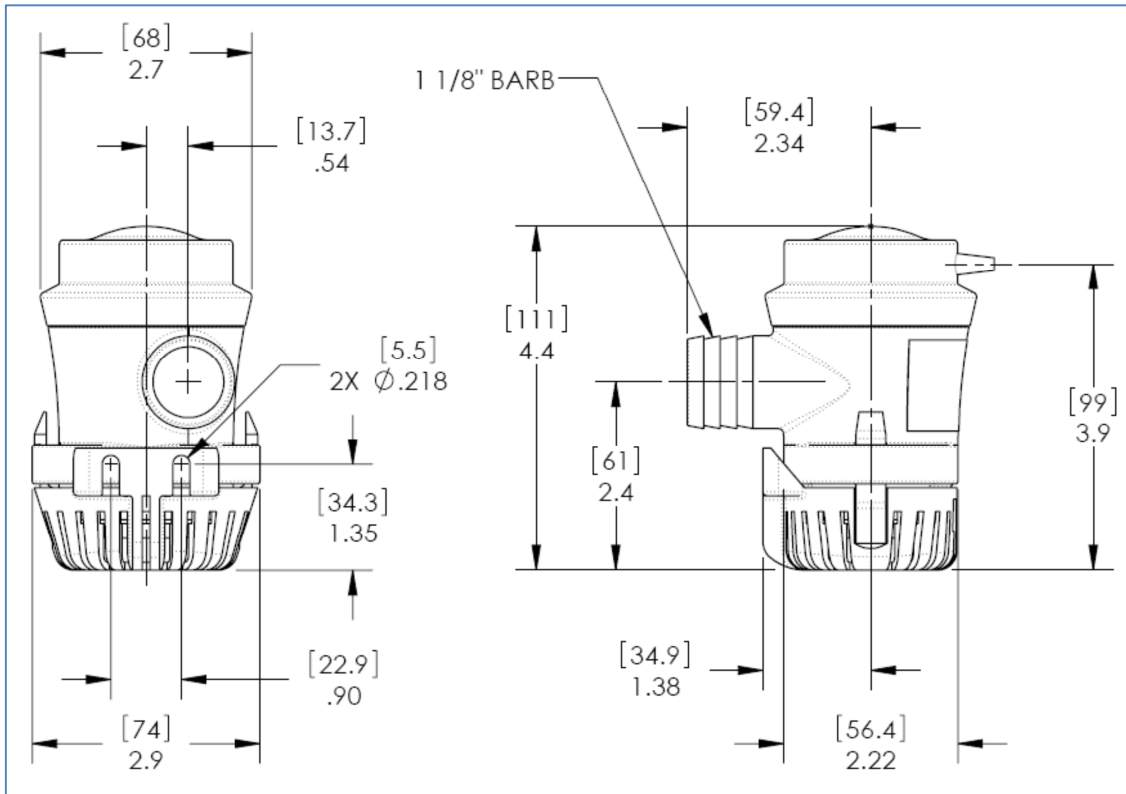

WATER PURIFICATION
 3545 Harbor Gateway South, Suite 103, Costa Mesa, CA 92626, (800) 854-3218 www.SHURFLO.com

All Pentair trademarks and logos are owned by Pentair, Inc. All other brand or product names are trademarks or registered marks of their respective owners. Because we are continuously improving our products and services, Pentair reserves the right to change specifications without prior notice. Pentair is an equal opportunity employer.