

# RV PRODUCT DATA SHEET

**OEM:** 4009-101-A65

**AFTERMARKET:** N/A

**APPLICATION**

Multi-fixture RV adjustable by-pass fresh water pump installation. Other uses may include 12V DC pressurized water systems in cabins. This pump may be used for general fresh water transfer.

**PUMP:**

Type: 4 Chamber Diaphragm pump  
 Ports: 1/2"-14 NPSM-Male.  
 Liquid: 54 °C [130 °F] Max  
 Dry-Prime: 1.82 M [6 feet]  
 Inlet PSI: 2.1 Bar [30 PSI] Max  
 Run Dry: Yes

**ELECTRICAL:**

Motor: 12VDC Permanent Magnet, Intermittent Duty  
 Protection: Thermal Overload, Automatic Restart  
 Leads: 16 AWG, 25 cm [10"] Red +, 33 cm [13"] Black -  
 Fuse: 10 Amp Recommended  
 Control: Shut-Off 3.0 Bar [55 PSI]  
 Restart 2.8 Bar [40 PSI]  
 Max By-Pass 4.3 [62 PSI]

**MATERIALS:**

Housing: Polypro  
 Valves: EPDM  
 Diaphragm: Santoprene  
 Hardware: Stainless and Zinc Plated Steel

**APPROVALS:**

CSA, CE, e-Mark

**WARRANTY:**

Contact SHURflo Europe for details

**SHIPPING:**

Net Weight: 2.3 Kg [5 Lb] each  
 Carton Quantity: 12  
 Carton Weight: 27 Kg [60 Lb]  
 Carton Size: 60.9cm x 45.7cm x 27.9cm  
 [24"L x 18"W x 11"H]

**RELATED DOCUMENTS:**

Catalog: MS-030-138  
 Installation Manual: 911-1023  
 Applications Spec Guide: MS-020-005



SHURflo's New 4009 series fresh water pump design was created with unique one-piece diaphragm and internal by-pass, assuring long life and top performance in all plumbing systems. Designed as the next legendary pump to exceed the expectations of our customers, the 4009 series pump is constructed for high flow demand, low noise and no rapid cycling. SHURflo's quality reputation has been built on the reliability and dependability of every pump we build. The 4009 series fresh water automatic demand pump is super quiet, thermally protected and can run dry without damage.

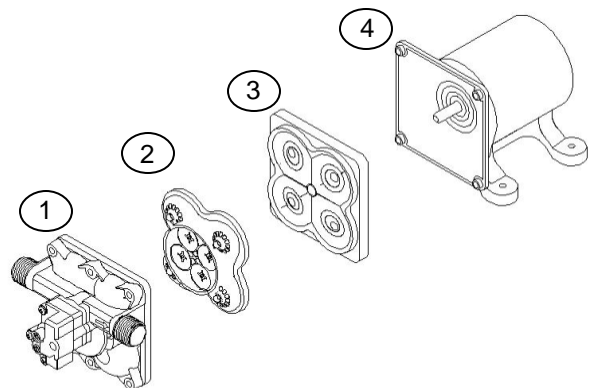

**Replacement Kits**

Number	Description	Part Number
1	Upper Assy	94-800-00
2	Valve Assy	94-800-01
3	Drive Assy	94-800-02
4	Motor	94-11-302-00CE
Not Shown	Check Valve	94-800-03
1,2,3	Pump Head	94-800-04
Not Shown	Pressure Sw.	94-800-05

### TYPICAL PERFORMANCE

PRESSURE		FLOW		CURRENT
BAR	PSI	GPM	LPM	AMPS
0.0	0	3.0	11.3	2.2
0.7	10	2.2	8.3	3.3
1.4	20	1.8	6.8	4.3
2.1	30	1.5	5.7	5.1
2.8	40	1.2	4.5	6.0
3.4	50	0.5	1.9	6.8
4.1	60	0.0	0.0	6.6

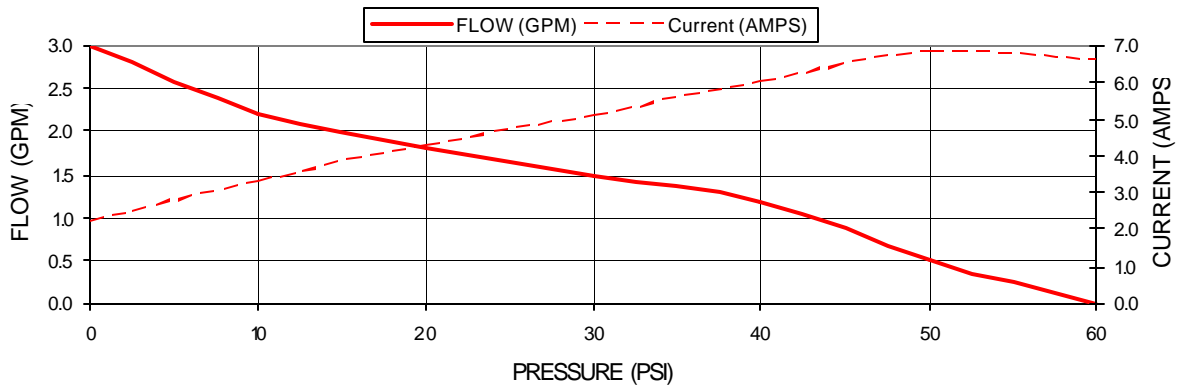

### DIMENSIONS [mm]

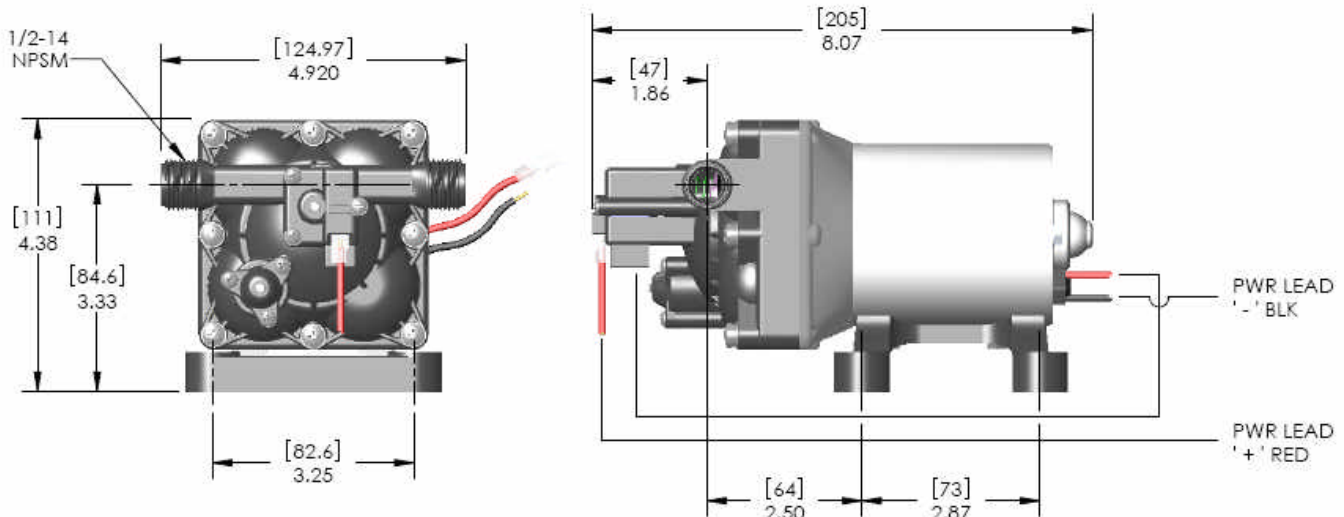

Visit our Web Site at <http://www.shurflo.com>  
 Shurflo reserves the right to update specifications,  
 change prices, or make substitutions without notice.

**SHURflo Europe, Middle East, Africa**  
**Pentair Water Belgium bvba**  
 Industriepark Wolfstee, Toekomstlann 30  
 B-2200 Herentals, Belgium  
 Phone + 32-14-283500 Fax + 32-14-283505



**SHURflo®**



**Pentair  
 Water**  
 FLOW TECHNOLOGIES GROUP